



*A proven history of performance and durability*

## Vortec 3.0L I-4 Marine Engine

### Features & Benefits

#### **MPFI Version:**

- Multi-port electronic fuel injection (MPFI) version that uses gasoline only
- Capable of meeting current and future emissions regulations
- Cylinder head targets fuel injectors to back of intake valves for quick response to changing conditions
- Stainless steel MPFI fuel rail resists corrosion
- Shipped with HVS coil and 58X crank sensor

#### **Carb Version:**

- High Energy Ignition (HEI) distributor and coil are shipped on the engine as standard equipment

#### **All Versions**

- A high-flow cylinder head with straighter intake ports and a higher compression ratio delivers impressive horsepower
- Cylinder heads feature sintered powder metal exhaust valve seat inserts for improved durability
- State-of-the-art coolant pump seal uses a combination of advanced materials to provide superb sealing action under extreme conditions
- Nodular iron crankshaft for increased strength and engine life
- Camshaft is specifically designed for marine duty cycles and optimized for maximum performance
- High-silicon cast aluminum pistons ensure optimum performance for the life of the engine
- Cylinder case has brass water jacket core support plugs for resistance to corrosion
- 14" diameter flywheel provides common size with most GM engines



*Sequential Fuel Injection*

### Available Options

- An electronic control module (ECM) and related hardware are available in kit form. The ECM uses state-of-the-art technology to optimize fuel and spark requirements.



*MEFI-5 (Marine Electronic Fuel Injection - Fifth-Generation), is an advanced engine controller capable of meeting all the emissions, OBD-M and driveability requirements of marine applications.*

**Vortec 3.0L Feature Focus**

GM Powertrain takes its expertise in designing outstanding Vortec truck and SUV engines and leverages it to make sophisticated yet extremely durable marine engines. In addition, the well-recognized Vortec brand name by itself has become a valuable selling tool for OEMs.



Many of GM marine engines are Vortec engines. Vortec means uncompromised power — outstanding power with no sacrifice in fuel efficiency or durability and very little required maintenance.

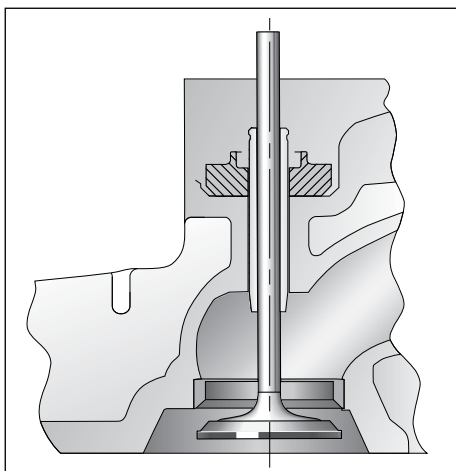

The exhaust valve seat inserts in the cylinder head provide superb durability.



The compact packaging of the Vortec 3.0L gasoline engine allows for excellent fuel economy with an impressive power-to-weight ratio.

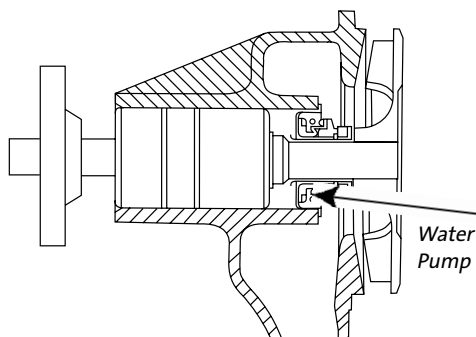

The improved, advanced-design water pump seal reflects GM Powertrain's commitment to continuous improvement.

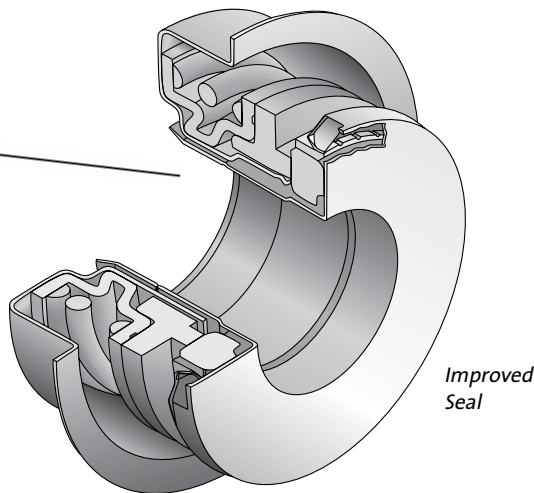

Improved Seal

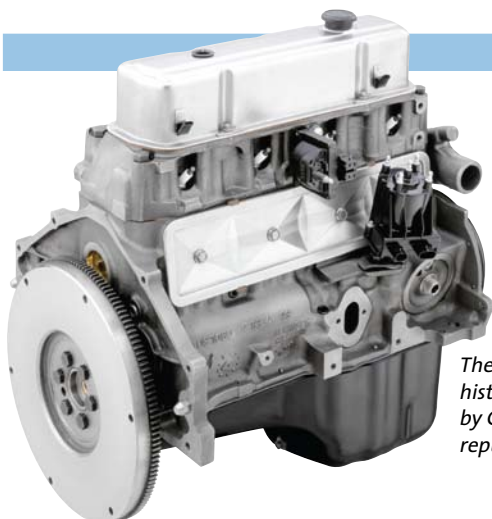

The Vortec 3.0L engine, with the longest history of any marine engine offered by GM Powertrain, has a well-earned reputation for durability and reliability.

### Specifications

**Type:** 3.0L I-4

**Displacement:** 181 cid (2966.59 cc)

**Engine Orientation:** Longitudinal

**Compression Ratio:** 9.2:1

**Valve Configuration:** Pushrod Actuated  
Overhead Valves  
(2 valves per cylinder)

**Assembly Site:** Toluca, Mexico

**Valve Lifters:** Hydraulic Flat Tappet

**Firing Order:** 1 - 3 - 4 - 2

**Bore x Stroke:** 101.60 x 91.44 mm

**Bore Center:** 112.26 mm

**Bore Area:** 324.29 cm<sup>2</sup>

**Fuel System:** N/A (LW6)  
MPFI Fuel Rail and Injectors (LMX)

**Fuel Type:** Regular Unleaded

**Horsepower:**

143 hp (107 kW) @ 4800 rpm (LMX)

140 hp (104 kW) @ 4800 rpm (LW6)

**Torque:**

178 lb-ft (241 Nm) @ 3600 rpm (LMX)

177 lb-ft (240 Nm) @ 3600 rpm (LW6)

Actual power levels may vary depending on OEM calibration and application.

**Fuel Shutoff:** OEM Defined

**Shipping Weight:** 363 lb (165 kg)

**Materials:**

Block: Cast Iron

Cylinder head: Cast Iron with exhaust  
valve seat inserts

Intake manifold: Customer Supplied

Exhaust manifold: Customer Supplied

Main bearing caps: 2 -Bolt Cast Iron

Crankshaft: Nodular Cast Iron

Camshaft: Marine Profile

Connecting rods: Powdered Metal

Information may vary with application. All specifications listed are based on the latest product information available at the time of publication. The right is reserved to make changes at any time without notice.

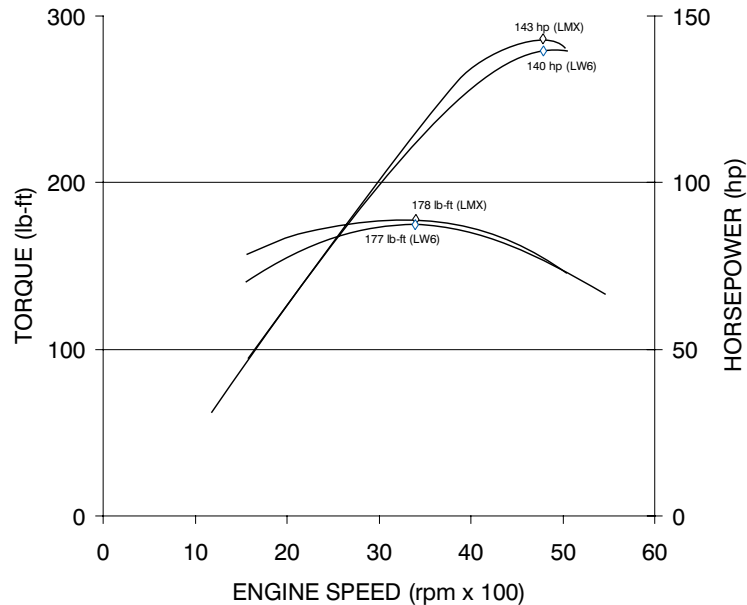

Actual power levels may vary depending on OEM calibration and application.

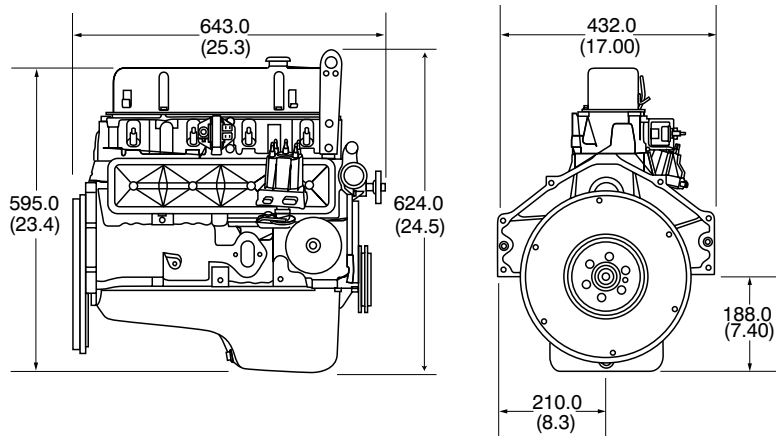

**GM Powertrain**

[www.gmpowertrain.com](http://www.gmpowertrain.com)