



C10 SERIES

GVW Ratings up to 5400 lb

C10 SERIES—STEPSIDE PICKUPS

Six-Cylinder Models

CS10704 Stepside Pickup
CE10904 Stepside Pickup

V8 Models

CE10704 Stepside Pickup
CE10904 Stepside Pickup

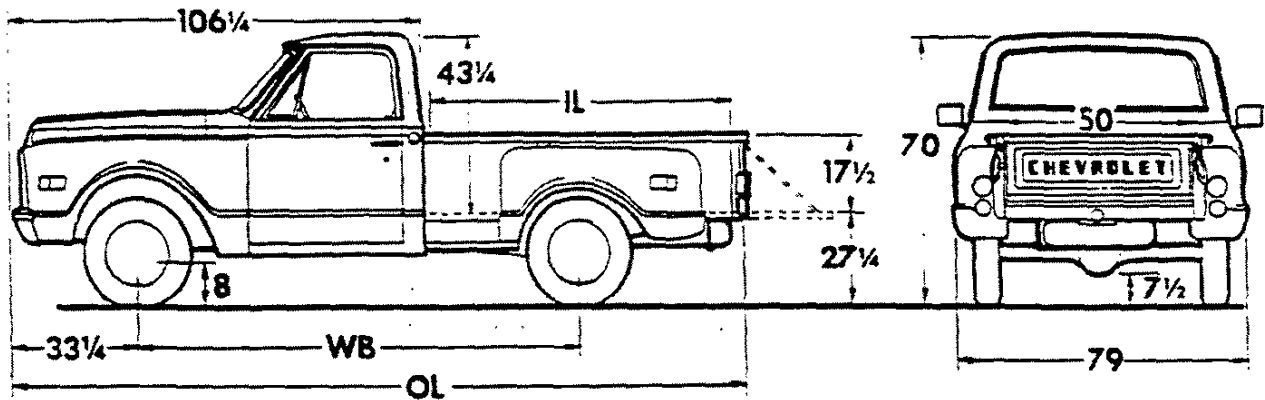

Models	Dimensions (in)*			→Curb Weights (lb)			Payload Wt. Dist.*	
	WB	IL	OL	Front	Rear	Total	Front	Rear
CS10704 CE10704	115	78 1/4	188 1/2	2060 2166	1468 1481	3528 3647	1%	99%
CE10904 CE10904	127	98	207 1/4	2156 2258	1465 1472	3621 3730	3	97

*Estimate based on water-level loading.

*Dimensions with std equipment, unloaded.

C10 SERIES—FLEETSIDE PICKUPS

Six-Cylinder Models

CS10734 Fleetside Pickup
CS10934 Fleetside Pickup

V8 Models

CE10734 Fleetside Pickup
CE10934 Fleetside Pickup

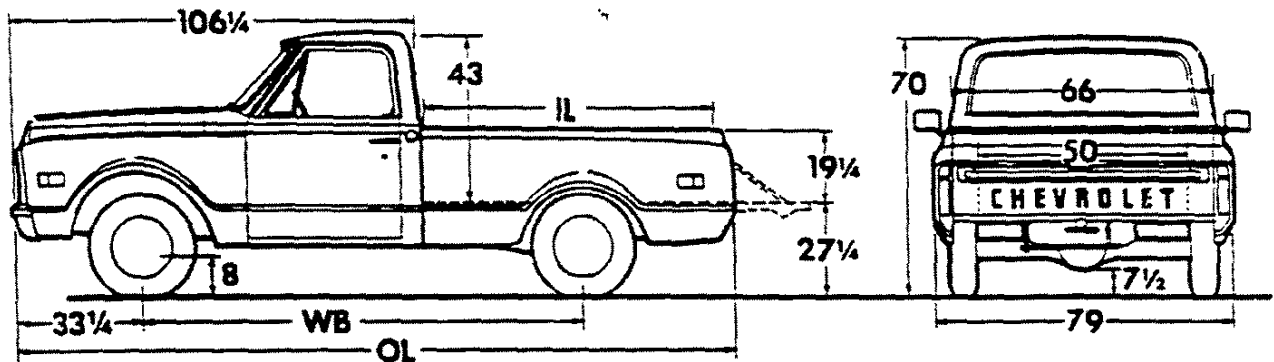

Models	Dimensions (in)*			→Curb Weights (lb)			Payload Wt. Dist.*	
	WB	IL	OL	Front	Rear	Total	Front	Rear
CS10734 CE10734	115	78 1/4	188 1/2	2075 2181	1538 1551	3613 3732	2%	98%
CS10934 CE10934	127	98	207 1/4	2177 2279	1539 1546	3716 3825	4	96

*Estimate based on water-level loading.

*Dimensions with std equipment, unloaded.

D SERIES

C10 SERIES—CHASSIS-CABS

Six-Cylinder Models

CS10703 Chassis-Cab
CS10903 Chassis-Cab

V8 Models

CE10703 Chassis-Cab
CE10903 Chassis-Cab

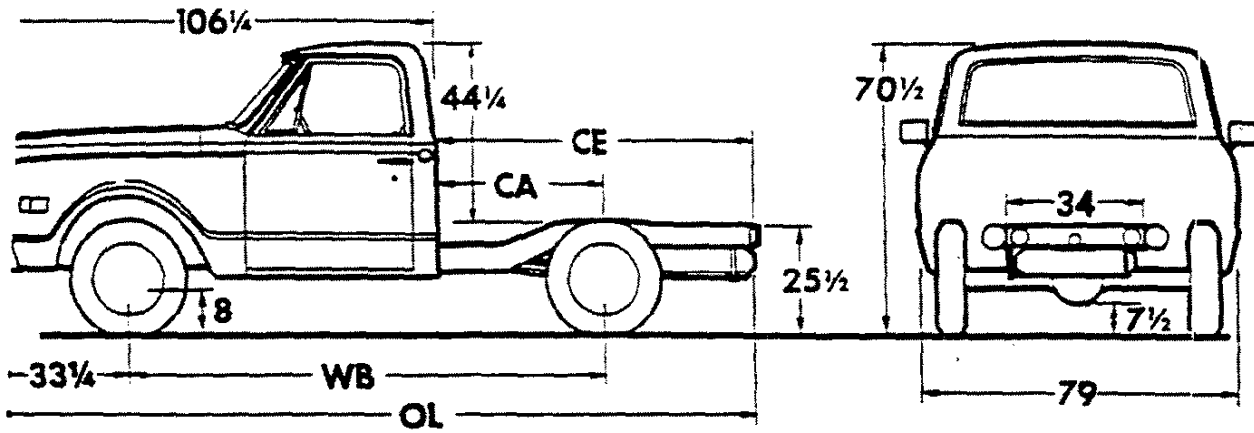

Models	Dimensions (in)★				→Curb Weights (lb)			Body-Payload Wt. Dist.*		
	WB	CA	CE	OL	Front	Rear	Total	Body	Front	Rear
CS10703					2079	1116	3195	6'	3%	97%
CE10703	115	42	75 1/2	181 1/4	2190	1124	3314	6 1/2'	1	99
CS10903					2130	1086	3216	7'	8	92
CE10903	127	54	95 1/2	201 1/4	2235	1090	3325	7 1/2'	6	94
								8'	3	97

*Estimate based on water-level loading.

★Dimensions with std equipment, unloaded.

K10 SERIES

GVW Ratings up to 5600 lb

K10 SERIES—STEPSIDE PICKUPS

Six-Cylinder Models

KS10704 Stepside Pickup
KS10904 Stepside Pickup

V8 Models

KE10704 Stepside Pickup
KE10904 Stepside Pickup

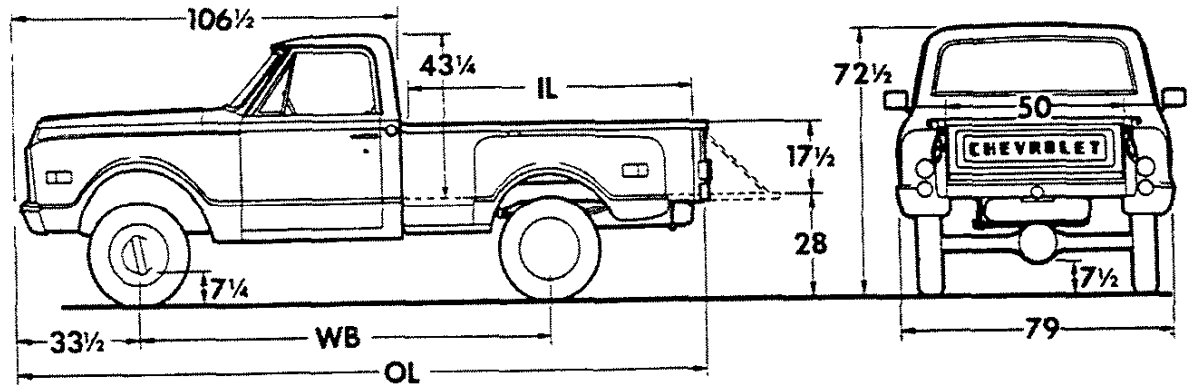

Models	Dimensions (in)★			→Curb Weights (lb)			Payload Wt. Dist.*	
	WB	IL	OL	Front	Rear	Total	Front	Rear
KS10704 KE10704	115	78	188 3/4	2294 2402	1566 1575	3860 3977	1%	99%
KS10904 KE10904	127	98	208	2428 2539	1581 1587	4009 4126	3	97

*Estimate based on water-level loading.

★ Dimensions with std equipment, unloaded.

K10 SERIES

K10 SERIES—FLEETSIDE PICKUPS

Six-Cylinder Models

KS10734 Fleetside Pickup
KS10934 Fleetside Pickup

V8 Models

KE10734 Fleetside Pickup
KE10934 Fleetside Pickup

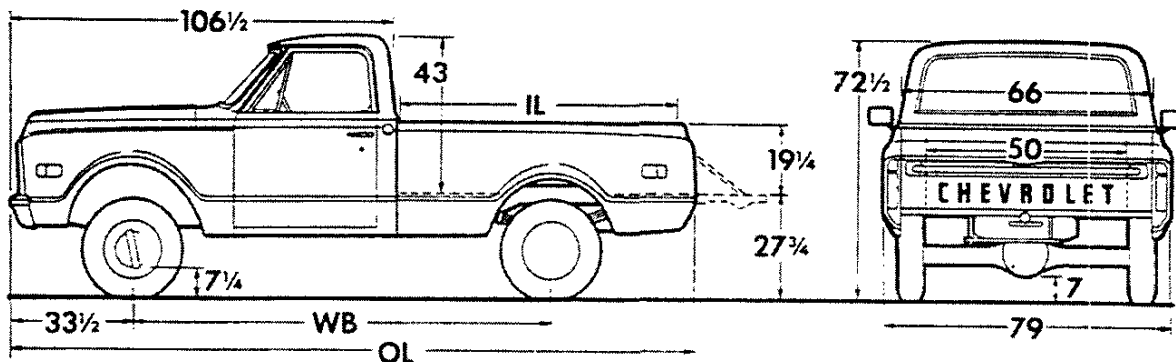

Models	Dimensions (in)★			→ Curb Weights (lb)			Payload Wt. Dist. [†]	
	WB	IL	OL	Front	Rear	Total	Front	Rear
KS10734	115	78	188¾	2306	1639	3945	2%	98%
KE10734				2415	1647	4062		
KS10934	127	98	208	2446	1658	4104	4	96
KE10934				2557	1664	4221		

*Estimate based on water-level loading.

★ Dimensions with std equipment, unloaded.

C10 SERIES (EXCEPT SUBURBAN CARRYALLS)

STANDARD EQUIPMENT

Air Cleaner: Oiled-paper element

Axle, Front: Independent; capacity 2700-lb

Axle, Rear: Hypoid semi-floating type; ratio 3.73; capacity 3500-lb

➔ **Battery:** 12-volt; side terminal connectors

CS10: 54-plate; capacity 45 amp-hr

CE10: 66-plate; capacity 61 amp-hr

Brakes, Service: Hydraulic; self-adjusting; dual system

Front: Single-piston caliper disc type, 11.86" rotor

Rear: Drum and shoe type; size—11" x 2"

Rear brake area:—drum 138.2 sq in; lining 84.4 sq in

Brake, Parking: Cable to rear wheels; area 84.4 sq in; foot operated

Bumper: Painted; front only

Cabs: See *Model Options and Cabs, Bodies & Colors section*

Carburetor: CS10: single-barrel downdraft

CE10: two-barrel downdraft

Clutch: CS10: diameter 10"; area 100 sq in

CE10: diameter 11"; area 124 sq in

Cooling: CS10: 1¼" radiator core, cross-flow type; 446-sq-in area; 15-lb pressure cap

CE10: 1¼" radiator core, cross-flow type; 480-sq-in area; 15-lb pressure cap

Controls & Instruments: Light switch; windshield wiper-washer switch; headlight beam control; speedometer; odometer; fuel gauge. Lights for generator, oil pressure, engine temperature, brake warning, direction signals and high beam indicator. Ignition switch with accessory position. Direction signal control with freeway lane-change position. Hazard warning switch

Emission Control Equipment: See Engine & Clutch section for types used

Engine: CS10: 250 Six

Gross horsepower..... 145 @ 4200 rpm

Net horsepower..... 110 @ 4000 rpm

Gross torque, lb-ft..... 230 @ 1600 rpm

Net torque, lb-ft..... 185 @ 1600 rpm

CE10: 307 V8

Gross horsepower..... 200 @ 4600 rpm

Net horsepower..... 135 @ 4000 rpm

Gross torque, lb-ft..... 300 @ 2400 rpm

Net torque, lb-ft..... 235 @ 2400 rpm

Exhaust System: Single; fully aluminized; unitized muffler-tailpipe

Filter, Fuel: Plastic mesh in fuel tank

CS10: Paper type in carburetor

CE10: Sintered bronze in carburetor

Filter, Oil: Full-flow; 1-quart; throwaway type

Frame: 39,000-lb-test steel; section modulus 2.98

Fuel Pump: Mechanically actuated diaphragm

Generator: 37-amp Delcotron

GVW Plate: See GVW Selector

Heater & Defroster: Deluxe-Air

Lights & Reflectors:

03 models: Two 7" Power Beam headlights; two Class A front combination parking/direction signals; two Class A rear combination tail/stop/direction signals; two front side marker combination lights & reflectors; two backup; one license; instrument panel & dome. Front side marker lights flash with turn signals

04 & 34 models: Same as 03 models plus two rear side marker combination lights & reflectors

Mirror, Rearview: Exterior chrome RH & LH 4½" x 6" head with fixed arm and inside 10" vinyl-edged prismatic

Seat: Full-width; vinyl trim

Seat Belts: Includes retractors; driver and passenger

Shock Absorbers: Front & rear; piston diameter 1"

Springs, Front: Coil; capacity 1350-lb each

Springs, Rear: Coil; capacity 1250-lb each

Steering: Ball-gear, ratio 24:1; wheel, oval 17½" x 17", 2-spoke

Tank, Fuel: Back of seat in cab; capacity approx 20 gallons; pressure/vacuum relief cap; anti-overfill

Tires: Five bias-belted ply tubeless G78-15B(4PR) front, single rear and spare

Tools: 2500-lb mechanical jack; wheel wrench

Transmission: 3-speed fully synchronized; steering column gearshift; ratios 2.85, 1.68, 1.00, 2.95 (rev)

Wheels: Five 15" x 6"; attachment, 5 studs on 5" circle; spare carrier under frame; 4 painted hubcaps

Windshield Wipers & Washer: Electric; 2-speed wipers

GVW SELECTOR

GVW Rating (lb)	Minimum Equipment Required for GVW Rating		
	Tires, Front	Tires, Rear	Chassis Equipment
4400	G78-15B(4PR) (TL or TB)	G78-15B(4PR) (TL or TB)	Standard
5400	H78-15B(4PR) (TL)	H78-15B(4PR) (TL)	2000-lb ea rear spring; Power Brakes
	6.50-16C(6PR) (TB) (TT)	6.50-16C(6PR) (TB) (TT)	

TL—Tubeless TB—Tube type TT—Truck type

March 15, 1971

➔ Indicates Change

Conventional Gasoline—10: Page 5

K10 SERIES (EXCEPT SUBURBAN CARRYALLS)

STANDARD EQUIPMENT

- Air Cleaner:** Oiled-paper element
- Axle, Front:** Hypoid, ratio 3.73; capacity 3300 lb; 40 degree turn angle; yoke and trunion universal joints
- Axle, Rear:** Hypoid semi-floating type; ratio 3.73; capacity 3300 lb
- **Battery:** 12-volt; side terminal connectors
 KS10: 54-plate; capacity 45 amp-hr
 KE10: 66-plate; capacity 61 amp-hr
- Brakes, Service:** Hydraulic; vacuum power; self-adjusting; dual system
 Front: Single-piston caliper disc type, 11.86" rotor
 Rear: Drum and shoe type; size—11" x 2"
 Rear brake area: drum 138.2 sq in; lining 84.4 sq in
- Brake, Parking:** Cable to rear wheels; area 84.4 sq in; foot operated
- Bumper:** Front only, painted
- Cabs:** See *Model Options and Cabs, Bodies & Colors section*
- Carburetor:** KS10: single-barrel downdraft
 KE10: two-barrel downdraft
- Clutch:** KS10: diameter 10"; area 100 sq in
 KE10: diameter 11"; area 124 sq in
- Cooling:** KS10: 1¼" radiator core, cross-flow type; 446-sq-in area; 15-lb pressure cap
 KE10: 1¼" radiator core, cross-flow type; 480-sq-in area; 15-lb pressure cap
- Controls & Instruments:** Light switch; windshield wiper-washer switch; headlight beam control; speedometer; odometer; fuel gauge. Lights for generator, oil pressure, engine temperature, brake warning, direction signals and high beam indicator. Ignition switch with accessory position. Direction signal control with freeway lane-change position. Hazard warning switch
- Emission Control Equipment:** See Engine & Clutch section for types used
- Engine:** KS10: 250 Six
 Gross horsepower..... 145 @ 4200 rpm
 Net horsepower..... 110 @ 4000 rpm
 Gross torque, lb-ft..... 230 @ 1600 rpm
 Net torque, lb-ft..... 185 @ 1600 rpm
 KE10: 307 V8
 Gross horsepower..... 200 @ 4600 rpm
 Net horsepower..... 135 @ 4000 rpm
 Gross torque, lb-ft..... 300 @ 2400 rpm
 Net torque, lb-ft..... 235 @ 2400 rpm
- Exhaust System:** Single; fully aluminized; unitized muffler-tailpipe
- Filter, Fuel:** Plastic mesh in fuel tank
 KS10: Paper type in carburetor
 KE10: Sintered bronze in carburetor
- Filter, Oil:** Full-flow; 1-quart; throwaway type
- Frame:** 39,000-lb-test steel; section modulus 2.70 (KS-KE107 models); 3.48 (KS-KE109 models)
- Fuel Pump:** Mechanically actuated diaphragm
- Generator:** 37-amp Delcotron
- GVW Plate:** See GVW Selector
- Heater & Defroster:** Deluxe-Air
- Lights & Reflectors:**
 Two 7" Power Beam headlights; two Class A front combination parking/direction signals; two Class A rear combination tail/stop/direction signals; two front and two rear side marker combination lights & reflectors; two backup; one license; instrument panel & dome. Front side marker light; flash with turn signals
- Mirror, Rearview:** Exterior chrome RH & LH 4½' x 6" head with fixed arm and inside 10" vinyl-edged prismatic
- Seat:** Full-width, vinyl trim
- Seat Belts:** Driver & passenger; includes retractors
- Shock Absorbers:** Front & rear; piston diameter 1"
- Springs, Front:** Tapered-leaf; capacity 1450 lb each
- Springs, Rear:** Two-stage, combination multi-leaf & tapered-leaf; capacity 1800 lb each
- Steering:** Ball-gear, ratio 24:1, wheel, oval 17½" x 17", 2-spoke
- Tank, Fuel:** Back of seat in cab; capacity approx 20 gallons; pressure/vacuum relief cap; anti-overfill
- Tires:** Five bias-belted ply tubeless G78-15B(4PR) front, single rear and spare
- Tools:** 2500-lb mechanical jack; wheel wrench
- Transfer Case:** New Process 205, 2-speed; ratios 1.96 & 1.00; power take-off opening on left side; single control lever
- Transmission:** 3-speed fully synchronized; steering column gearshift; ratios 3.03, 1.75, 1.00, 3.02 (rev)
- Wheels:** Five 15" x 6.0"; attachment, 6 studs on 5½" circle; spare carrier under frame
- Windshield Wipers & Washer:** Electric; 2-speed wipers

GVW SELECTOR

GVW Rating (lb)	Minimum Equipment Required for GVW Rating		
	Tires, Front	Tires, Rear	Chassis Equipment
5200	G78-15B(4PR) (TL or TB)	G78-15B(4PR) (TL or TB)	Standard
5600	H78-15B(4PR) (TL)	H78-15B(4PR) (TL)	
	6.50-16C(6PR) (TB) (TT)	6.50-16C(6PR) (TB) (TT)	

TL—Tubeless TB—Tube type TT—Truck type

NOTES

10 SERIES POWER TEAMS (EXCEPT SUBURBAN CARRYALL)

→ C10 SERIES

ENGINE	TRANSMISSION	AXLE RATIOS	
		STD	OPT
250 Six 292 Six	Chevrolet 3-Speed	3.73	3.07; 4.11
	Chevrolet CH465 4-Speed	3.73	3.07; 4.11
250 Six	Powerglide	3.73	4.11
250 Six 292 Six	Turbo Hydra-matic	3.73	3.07; 4.11
307 V8	Chevrolet 3-Speed	3.73	3.07; 4.11
	Chevrolet CH465 4-Speed	3.07	3.73; 4.11
	Powerglide	3.73	4.11
	Turbo Hydra-matic	3.07	3.73; 4.11
350 V8	Chevrolet 3-Speed H.D.	3.07	3.73; 4.11
	Chevrolet CH465 4-Speed	3.07	3.73; 4.11
	Turbo Hydra-matic	3.07	3.73; 4.11
400 V8	Chevrolet 3-Speed H.D.	3.07	—
	Turbo Hydra-matic	3.07	—

K10 SERIES

ENGINE	TRANSMISSION	TRANSFER CASE	AXLE RATIOS	
			STD	OPT
250 Six 292 Six	Chevrolet 3-Speed H.D.	New Process 205	3.73	—
	Chevrolet CH465 4-Speed		3.73	—
	Turbo Hydra-matic		3.73	—
307 V8	Chevrolet 3-Speed H.D.	New Process 205	3.73	—
	Chevrolet CH465 4-Speed		3.73	—
	Turbo Hydra-matic		3.73	—
350 V8	Chevrolet 3-Speed H.D.	New Process 205	3.07	3.73
	Chevrolet CH465 4-Speed		3.07	3.73
	Turbo Hydra-matic		3.07	3.73

OPTIONAL ENGINE RATINGS

CS/KS10 with 292 Six

Gross Horsepower 165 @ 4000 rpm
 Net Horsepower 125 @ 3600 rpm
 Gross Torque, lb-ft. 270 @ 1600 rpm
 Net Torque, lb-ft. 225 @ 2400 rpm

CE/KE10 with 350 V8

Gross Horsepower 250 @ 4600 rpm
 Net Horsepower 170 @ 3600 rpm
 Gross Torque, lb-ft. 350 @ 3000 rpm
 Net Torque, lb-ft. 310 @ 2400 rpm

CE10 with 400 V8

Gross Horsepower 300 @ 4800 rpm
 Net Horsepower 240 @ 4400 rpm
 Gross Torque, lb-ft. 400 @ 3200 rpm
 Net Torque, lb-ft. 340 @ 3200 rpm

C10 SERIES — GASOLINE 2-WHEEL DRIVE (4400-lb — 5400-lb GVW) K10 SERIES — GASOLINE 4-WHEEL DRIVE (5200-lb — 5600-lb GVW)

1971 MODELS WITH STANDARD EQUIPMENT

Model Number and Description	Wheel-base	Factory D & H	List Price	Mfr's Suggested Retail Price*	Destination Charge & Group Number	Total
→ 6-Cylinder 145-hp High Torque 250 Engine						
CS10703 Chassis-Cab (42" Cab-Axle)	115"	\$194.00	\$2452.00	\$2646.00	23
CS10704 Pickup—Stepside (6½ ft)	115"	206.00	2600.00	2806.00	19
CS10734 Pickup—Fleetside (6½ ft)	115"	206.00	2600.00	2806.00	19
CS10903 Chassis-Cab (54" Cab-Axle)	127"	197.00	2482.00	2679.00	23
CS10904 Pickup—Stepside (8 ft)	127"	209.00	2635.00	2844.00	19
CS10934 Pickup—Fleetside (8 ft)	127"	209.00	2635.00	2844.00	19
KS10704 Pickup—Stepside (6½ ft)	115"	249.00	3165.00	3414.00	21
KS10734 Pickup—Fleetside (6½ ft)	115"	249.00	3165.00	3414.00	21
KS10904 Pickup—Stepside (8 ft)	127"	251.00	3200.00	3451.00	21
KS10934 Pickup—Fleetside (8 ft)	127"	251.00	3200.00	3451.00	21
→ 8-Cylinder 200-hp High Torque 307 Engine						
CE10703 Chassis-Cab (42" Cab-Axle)	115"	203.00	2567.00	2770.00	23
CE10704 Pickup—Stepside (6½ ft)	115"	215.00	2715.00	2930.00	19
CE10734 Pickup—Fleetside (6½ ft)	115"	215.00	2715.00	2930.00	19
CE10903 Chassis-Cab (54" Cab-Axle)	127"	205.00	2597.00	2802.00	23
CE10904 Pickup—Stepside (8 ft)	127"	217.00	2750.00	2967.00	19
CE10934 Pickup—Fleetside (8 ft)	127"	217.00	2750.00	2967.00	19
KE10704 Pickup—Stepside (6½ ft)	115"	257.00	3280.00	3537.00	21
KE10734 Pickup—Fleetside (6½ ft)	115"	257.00	3280.00	3537.00	21
KE10904 Pickup—Stepside (8 ft)	127"	260.00	3315.00	3575.00	21
KE10934 Pickup—Fleetside (8 ft)	127"	260.00	3315.00	3575.00	21

* Manufacturer's Suggested Retail Prices do not include state and local taxes, license fees, options or accessories.

→ Indicates Change

C-K10 SERIES—GASOLINE

OPTIONS AND ACCESSORIES WHEN INSTALLED BY CHEVROLET

Description	Option Number	Factory D & H	List Price	Mfr's Suggested Retail Delivered Price [⊕]
-------------	---------------	---------------	------------	---

MODEL OPTIONS

(See Exterior and Interior Color Charts)

<p>→ Custom Deluxe: Not available when Cheyenne, Cheyenne Super or bucket seats are ordered. Includes bright metal rear window molding; vent window and windshield moldings; cigar lighter; dual horns; bright control knob trim and dome lamp bezel; fender nameplates; full-depth foam seat with cloth trim; door trim panels; color-keyed floor mat; door operated dome lamp switches and special insulation</p>	Z62		\$ 7.60	\$100.00	\$107.60
<p>Cheyenne: Includes full-depth foam seat with deluxe vinyl trim; carpeting; door trim panels; chromed front bumper; cigar lighter; headliner; cargo area lamp; bright control knob and pedal trim; rear window, vent window and windshield moldings; Cheyenne fender nameplates; bright side marker lamp bezels; dual horns; door operated dome lamp switches and special insulation</p>	Z84		14.90	196.00	210.90
<p>Chassis-Cab or Stepside Pickup models only. Also includes body side lower molding and bright fuel filler cap</p>	Z84		17.95	236.00	253.95
<p>→ Cheyenne Super: Includes full-depth foam seat with cloth trim; carpeting; door trim panels; bright moldings and wood grained trim with Cheyenne Super nameplate on glove box cover; wood grained gauge type instrument cluster; chromed front bumper; cigar lighter; headliner; cargo area lamp; bright control knob and pedal trim; rear window, vent window and windshield moldings; Cheyenne Super fender nameplates; bright side marker lamp bezels; dual horns; door operated dome lamp switches and special insulation</p>					
<p>Chassis-Cab or Stepside Pickup models only. Also includes chromed hub caps</p>	C10 models K10 models	YE9 YE9			Will Advise Will Advise
<p>Fleetside Pickup models only. Also includes body side upper and lower moldings plus bright fuel filler cap and tailgate latch</p>		YE9			Will Advise
<p>C10 models only</p>		YE9			Will Advise
<p>K10 models without 10.00-16.5 tires. Also includes chromed hub caps</p>		YE9			Will Advise
<p>K10 models with 10.00-16.5 tires</p>		YE9			Will Advise

POWER TEAMS AND AXLES

Engines:

<p>292 Six. CS-KS10 models only. Not available when Powerglide transmission is ordered. Includes 11" clutch</p>	L25		6.85	90.00	96.85
<p>350 V8. CE-KE10 models only. Includes 4-barrel carburetor, 12" coil clutch and 3.07 ratio rear axle</p>	LS9		3.20	42.00	45.20
<p>400 V8. CE10 models only. Not available when Powerglide or 4-speed transmission is ordered. Includes 4-barrel carburetor, dual exhausts, 12" coil clutch, 3.07 ratio rear axle with standard or Turbo Hydra-matic transmission</p>	L47		12.55	165.00	177.55
<p>Liquid Petroleum Gas Conversion. C10 models only. Not available when automatic transmission, HD clutch, 307 or 400 engine is ordered. Includes internal modifications of valves, compression ratio and heat shield</p>	L56		6.85	90.00	96.85

Transmissions:

<p>Powerglide. C10 models with standard engine only. Not available when 3.07 or 3.73 ratio rear axle is specified with 6.50-16 tires. Includes HD radiator</p>	M3S		15.20	200.00	215.20
<p>Turbo Hydra-matic. Includes HD radiator. CE10 models also include 3.07 ratio rear axle</p>					
<p>Without 400 engine</p>		M49	17.50	230.00	247.50
<p>With 400 engine</p>		M49	18.25	240.00	258.25
<p>Chevrolet 4-Speed. Not available when 400 engine is ordered</p>					
<p>CS-CE10700 models only. Includes 3.07 ratio rear axle with 307 or 350 engine</p>		M20	7.60	100.00	107.60
<p>CS-CE10900 models only. Includes 3.07 ratio rear axle with 307 or 350 engine</p>		M20	8.00	105.00	113.00
<p>K10 models only</p>		M20	8.00	105.00	113.00

⊕ State and local taxes not included.

→ Indicates Change

C-K10 SERIES—GASOLINE

OPTIONS AND ACCESSORIES WHEN INSTALLED BY CHEVROLET

Description	Option Number	Factory D & H	List Price	Mfr.'s Suggested Retail Delivered Price [◇]
Axles, Rear:				
3.07 Ratio. C10 models only. Not available when Powerglide transmission is ordered. Included when Turbo Hydra-matic or Chevrolet 4-speed transmission is ordered with 307 engine or when 3-speed or Turbo Hydra-matic transmission is ordered with 400 engine. Also included when 350 engine is ordered.	H01	\$.95	\$12.00	\$12.95
3.73 Ratio. Available only when 350 engine is ordered. Also available on C10 models when Turbo Hydra-matic or Chevrolet 4-speed transmission is ordered with 307 engine	H05	.95	12.00	12.95
4.11 Ratio. C10 models only. Not available when 400 engine is ordered	H04	.95	12.00	12.95
With 250, 292 or 307 engine	H04			
With 350 engine	H04	1.10	14.40	15.50
Without air conditioning	H04	.95	12.00	12.95
With air conditioning	H04			
Positraction	G80	4.75	62.00	66.75
OTHER OPTIONS				
Air Cleaner: Oil-bath. Capacity 1 quart. Not available on CE-KE10 models when 350 or 400 engine is ordered.	K48	.80	10.00	10.80
Air Conditioning, All-Weather: V8 models only. Includes HD radiator and 42-amp generator.	C60	30.40	400.00	430.40
Batteries: 12-volt				
→ Auxiliary: 53-amp-hr, 9-plate	TP2	3.45	45.00	48.45
Heavy-Duty: 80-amp-hr, 15-plate	T60	1.25	16.00	17.25
Belts, Seat: Installed for third passenger. Not available when bucket seats are ordered.	AM3	.50	6.50	7.00
Box, Tool Storage: CS-CE10934 models only. Includes 7" high, 28" wide and 17" deep reinforced plastic box with bottom hinge and separate key located on RH side forward of rear wheelhousing.	VK2	3.45	45.00	48.45
Brakes: Vacuum Power. C10 models only	I70	3.60	47.00	50.60
Bumpers:				
Painted				
Rear. Pickup models with standard painted front bumper only	V38	1.70	22.00	23.70
Rear step. Pickup models only	V43	3.65	48.00	51.65
→ Chromed				
Front and rear. Pickup models only. Not available when Cheyenne or Cheyenne Super is ordered.	V37	3.80	50.00	53.80
Front. Not available when painted rear bumper is ordered. Included when Cheyenne or Cheyenne Super is ordered.	V46	1.15	15.00	16.15
Rear. Pickup models with Cheyenne or Cheyenne Super only	VF1	2.70	35.00	37.70
→ Caps, Hub: Chromed. Included when Cheyenne Super is ordered.				
C10 models only	P03	.80	10.00	10.80
K10 models only. Not available when 10.00-16.5 tires are ordered.	P03	1.00	13.00	14.00
Carrier, Spare Wheel: Side mounted				
Fleetside Pickup models only	P13	1.10	14.00	15.10
Stepside Pickup models only				
Without chromed hub caps or wheel covers	P13	1.25	16.00	17.25
With chromed hub caps	P13	1.40	18.25	19.65
With wheel covers	P13	1.65	21.25	22.90
Clutch, Heavy-Duty: Diameter 11". CS-KS10 models only. Included when Chevrolet 4-speed transmission or 292 engine is ordered.	M01	.50	6.50	7.00
Cooling: HD radiator only. Included when air conditioning or automatic transmission is ordered.	V01	1.90	25.00	26.90

◇ State and local taxes not included.

→ Indicates Change

C-K10 SERIES—GASOLINE

OPTIONS AND ACCESSORIES WHEN INSTALLED BY CHEVROLET

Description	Option Number	Factory D & H	List Price	Mfr's Suggested Retail Delivered Price [⊙]
→ Floor, Pickup Box: Wood with steel skid strips. Fleetside Pickup models only	E81	\$ 1.45	\$19.00	\$20.45
→ Gauges:				
<i>Ammeter, temperature and oil pressure.</i> Included when Cheyenne Super is ordered	Z53	.95	12.00	12.95
<i>Tachometer</i> Without Cheyenne Super. Also includes ammeter, temperature and oil pressure gauges	U16	4.20	55.00	59.20
With Cheyenne Super	U16	<i>Will Advise</i>		
Generators:				
<i>42-amp Delcotron.</i> Included when air conditioning is ordered	K79	1.70	22.00	23.70
<i>61-amp Delcotron</i>	K76	2.30	30.00	32.30
Glass, Soft-Ray: All windows	A11	1.40	18.00	19.40
Guards, Door Edge	B93	.50	6.00	6.50
Harness, Camper Body Wiring: For camper body installation on Pickup models only	UY1	1.15	15.00	16.15
Hooks, Towing: Two, front. Not available with chromed bumper.	V76	1.40	18.00	19.40
Hubs, Front Free-Wheeling: K10 models only. Manual control at hubs.	F76	5.55	73.00	78.55
Lamps:				
→ Cargo Area. Included when Cheyenne or Cheyenne Super is ordered.	UF2	1.45	19.00	20.45
Roof Marker, Five	U01	1.90	25.00	26.90
→ Lighter, Cigar: Included when custom deluxe, Cheyenne or Cheyenne Super is ordered.	U37	.40	5.00	5.40
Mirrors, Exterior: Replaces standard LH and RH mirrors				
<i>Below-Eye-Line Type</i>				
7.5" x 10.5" painted	D29	1.50	19.50	21.00
7.5" x 10.5" stainless steel	DG4	2.70	35.00	37.70
<i>Camper Type</i>				
Painted	DF1	1.50	19.50	21.00
Stainless steel	DF2	3.75	49.00	52.75
→ Moldings, Custom: Fleetside Pickup models only.				
<i>Lower fender, door, cab panel and pickup box moldings plus bright fuel filler cap.</i> Included when Cheyenne, Cheyenne Super or deluxe two-tone paint is ordered.				
Without upper moldings (Option B85)	BX2	3.45	45.00	48.45
With upper moldings (Option B85)	BX2	3.05	40.00	43.05
<i>Upper fender, door, cab panel and pickup box moldings, bright taillight trim and fuel filler cap.</i> Not available when optional paint stripe is ordered. Included when Cheyenne Super is ordered.				
Without Cheyenne	B85	3.45	45.00	48.45
With Cheyenne	B85	3.05	40.00	43.05
Paints, Exterior: See Color and Trim Chart				
<i>Solid</i>		N.C.	N.C.	N.C.
<i>Conventional Two-Tone.</i> With white secondary color		1.90	25.00	26.90
<i>Custom Two-Tone</i>		1.90	25.00	26.90
→ Deluxe Two-Tone. Cab roof and area between upper and lower side moldings painted white. Fleetside Pickup models only.				
Without Cheyenne or Cheyenne Super. Available only when custom upper moldings are ordered. Includes custom lower moldings		8.75	115.00	123.75
With Cheyenne. Available only when custom upper moldings are ordered		5.70	75.00	80.70
With Cheyenne Super		5.70	75.00	80.70
Plate: <i>Serial Number:</i> (State of Pennsylvania) "K" Plate. Available on C10 models only when capacity 1750-lb each (leaf) or 2000-lb each (coil) HD rear springs and power brakes are ordered.				
	Z55	N.C.	N.C.	N.C.
Radios: Pushbutton control. Includes manual front antenna				
AM	U63	4.95	65.00	69.95
AM/FM	U69	10.75	141.00	151.75

⊙ State and local taxes not included.

→ Indicates Change

C-K10 SERIES—GASOLINE

OPTIONS AND ACCESSORIES WHEN INSTALLED BY CHEVROLET

Description	Option Number	Factory D & H	List Price	Mfr's Suggested Retail Delivered Price [⊙]
→ Seats:				
<i>Bucket, Driver and Passenger.</i> Not available when custom deluxe is ordered. Includes floor carpeting and console				
Without Cheyenne or Cheyenne Super	A50	\$10.50	\$138.00	\$148.50
With Cheyenne	A50	8.60	113.00	121.60
With Cheyenne Super	A50	<i>Will Advise</i>		
<i>Full-Depth Foam.</i> Not available when custom deluxe, Cheyenne or Cheyenne Super is ordered				
	Z52	2.15	28.00	30.15
Shock Absorbers:				
<i>Front and Rear, Heavy-Duty.</i> Not available when leaf-type rear suspension is ordered				
	F51	1.15	15.00	16.15
<i>Front, Heavy-Duty.</i> C10 models only. Available only when leaf-type rear suspension is ordered				
	F52	.60	7.50	8.10
<i>Rear, Heavy-Duty.</i> included when leaf-type rear suspension is ordered				
	G68	.65	8.00	8.65
<i>Superlift Rear.</i> C10 models only. Not available when leaf-type rear suspension is ordered				
	G66	3.45	45.00	48.45
Springs:				
<i>Front</i>				
Capacity 1500-lb each. C10 models only	F60	.50	6.00	6.50
Capacity 1750-lb each. K10 models only	F60	2.40	31.00	33.40
<i>Rear</i>				
Coil. Capacity 2000-lb each. C10 models only	G50	1.40	18.00	19.40
Leaf-Type. Capacity 1750-lb each, two-stage. C10 models with leaf-type suspension only	G50	1.40	18.00	19.40
<i>Auxiliary Rear.</i> Capacity 500-lb each. C10 models only. Not available when rear leaf-type suspension is ordered				
	G60	2.25	29.00	31.25
Stabilizer, Front: C10 models only				
	F59	1.40	18.00	19.40
Steering, Power:				
C10 models only	N40	9.50	125.00	134.50
K10 models only	N40	10.65	140.00	150.65
Steering Wheel, Comfortilt: Available only when optional transmission is ordered				
	N33	4.20	55.00	59.20
Stripes, Body Side Paint				
	D89	1.00	13.00	14.00
Support, Heavy-Duty Cross Sill: Chassis-Cab models only				
	F19	1.40	18.00	19.40
Suspension, Rear Leaf: C10 models only. Includes capacity 1250-lb each two-stage leaf-type rear springs and HD rear shock absorbers				
	G70	1.90	25.00	26.90
→ Switches, Dome Lamp: Door operated. Included when custom deluxe, Cheyenne or Cheyenne Super is ordered				
	C80	.35	4.00	4.35
Throttle Control: Manual				
	K31	1.10	14.00	15.10
Tires and Wheels: See following page				
→ Wheel Covers, Bright Metal: C10 models with G78-15 or H78-15 tires only				
Without Cheyenne Super	P01	1.90	25.00	26.90
With Cheyenne Super	P01	<i>Will Advise</i>		
Window, Sliding Rear				
	A28	3.80	50.00	53.80

⊙ State and local taxes not included.

→ Indicates Change

C-K10 SERIES—GASOLINE

TUBE-TYPE TIRES (Factory Installed)

Tire Size and Type			Rim Width Included In Tire Option	Option Number	Factory D & H	List Price	Mfr's Suggested Retail Delivered Price*
<small>All tires have black sidewalls except as indicated. Note: Front and rear tires must be of the same construction, rim width and diameter. K10 models require use of same tread type on front and rear wheels.</small>							
G78-15/B							
(Pass. type) —	Highway	(5) Front, rear & spare	6.00	RL5	N.C.	\$10.00	\$10.00
	Bias	(2) Front; C10 only	6.00	RL5	N.C.	4.00	4.00
	Belted Ply	(3) Front & spare; C10 only	6.00	RL5	N.C.	6.00	6.00
—	On-Off Road	(5) Front, rear & spare; K10 only	6.00	RL4	\$ 1.25	20.50	21.75
	Bias	(2) Rear; C10 only	6.00	RL4	.50	8.20	8.70
	Belted Ply	(3) Rear & spare; C10 only	6.00	RL4	.75	12.30	13.05
6.50-16/C							
(Pass. type) —	Highway	(5) Front, rear & spare	5.00	R61	1.75	31.50	33.25
	Original	(2) Front; C10 only	5.00	R61	.70	12.60	13.30
	Equipment	(3) Front & spare; C10 only	5.00	R61	1.05	18.90	19.95
—	On-Off Road	(5) Front, rear & spare; K10 only	5.00	R69	3.25	49.00	52.25
	Original	(2) Rear; C10 only	5.00	R69	1.30	19.60	20.90
	Equipment	(3) Rear & spare; C10 only	5.00	R69	1.95	29.40	31.35
6.50-16/C (6PR) Maximum Tire Capacity (Each)—Front (1610) Rear (1610)							
(Truck type) —	Highway	(5) Front, rear & spare	5.00	R65	4.25	71.50	75.75
	Nylon	(2) Front; C10 only	5.00	R65	1.70	28.60	30.30
		(3) Front & spare; C10 only	5.00	R65	2.55	42.90	45.45
—	On-Off Road	(5) Front, rear & spare; K10 only	5.00	R64	8.25	124.00	132.25
	Nylon	(2) Rear; C10 only	5.00	R64	3.30	49.60	52.90
		(3) Rear & spare; C10 only	5.00	R64	4.95	74.40	79.35

TUBELESS TIRES (Factory Installed)

G78-15/B							
(Pass. type) —	Highway	(5) Front, rear & spare	6.00	Std	N.C.	N.C.	N.C.
	Bias	(5) Front, rear & spare					
	Belted Ply	(White Stripe)	6.00	PUB	1.80	31.00	32.80
—	On-Off Road	(5) Front, rear & spare; K10 only	6.00	RL3	1.25	17.50	18.75
	Bias	(2) Rear; C10 only	6.00	RL3	.50	7.00	7.50
	Belted Ply	(3) Rear & spare; C10 only	6.00	RL3	.75	10.50	11.25
H78-15/B							
(Pass. type) —	Highway	(5) Front, rear & spare	6.00	PV5	2.00	22.50	24.50
	Bias	(2) Front; C10 only	6.00	PV5	.80	9.00	9.80
	Belted Ply	(3) Front & spare; C10 only	6.00	PV5	1.20	13.50	14.70
		(5) Front, rear & spare					
		(White Stripe)	6.00	PV6	4.00	56.50	60.50
—	On-Off Road	(5) Front, rear & spare; K10 only	6.00	RM1	3.25	40.00	43.25
	Bias	(2) Rear; C10 only	6.00	RM1	1.30	16.00	17.30
	Belted Ply	(3) Rear & spare; C10 only	6.00	RM1	1.95	24.00	25.95

TUBELESS FLOTATION-TYPE TIRES (Factory Installed)

10.00-16.5/C (6PR) Maximum Tire Capacity (Each)—Front (2330) Rear (2330)							
(Truck type) —	Highway	(5) Front, rear & spare; K10					
	Nylon	Fleetside Pickup models only	8.25	R79	31.25	417.50	448.75
—	On-Off Road	(5) Front, rear & spare; K10					
	Nylon	Fleetside Pickup models only	8.25	RR2	30.50	420.00	450.50

* State and local taxes not included.

C10 & K10 SERIES SUBURBAN CARRYALLS

GVW Ratings up to 5400 lb

C10 SERIES—SUBURBAN CARRYALLS*

Six-Cylinder Models

CS10906 Suburban Carryall
CS10916 Suburban Carryall

V8 Models

CE10906 Suburban Carryall
CE10916 Suburban Carryall

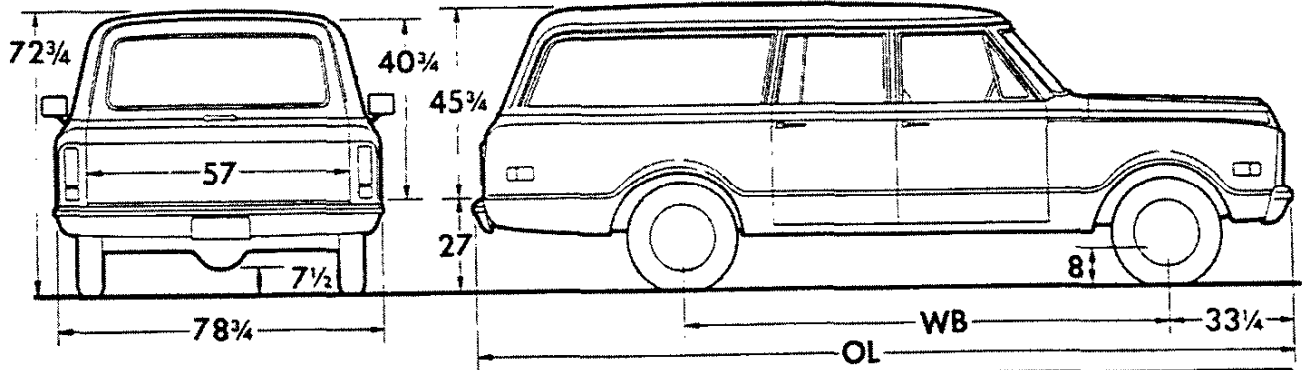

Models	Dimensions (in)★		→Curb Weights (lb)		
	WB	OL	Front	Rear	Total
CS10906 CE10906	127	215½	1992 2089	2000 2012	3992 4101
CS10916 CE10916	127	215½	1996 2093	2004 2016	4000 4109

★Dimensions with std equipment, unloaded.

GVW Ratings up to 5800 lb

K10 SERIES—SUBURBAN CARRYALLS*

Six-Cylinder Models

KS10906 Suburban Carryall
KS10916 Suburban Carryall

V8 Models

KE10906 Suburban Carryall
KE10916 Suburban Carryall

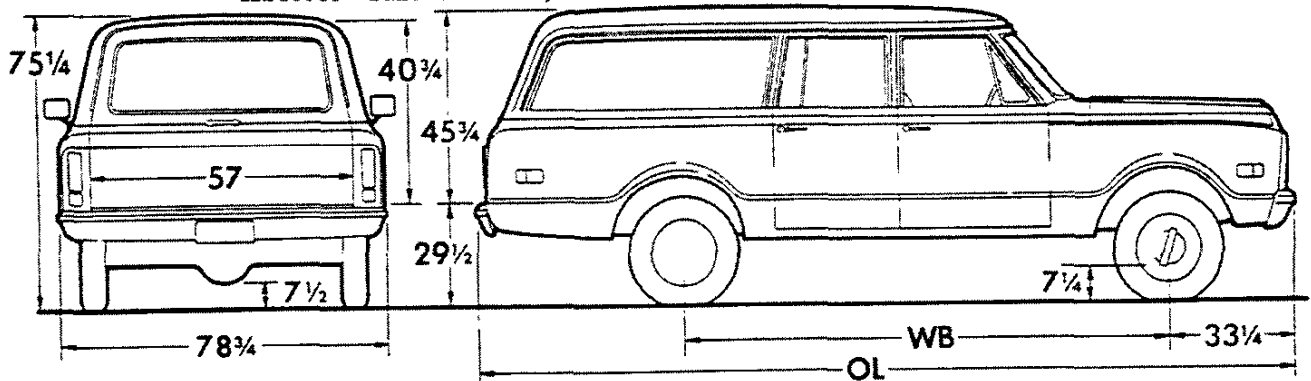

Models	Dimensions (in)★		→Curb Weights (lb)		
	WB	OL	Front	Rear	Total
KS10906 KE10906	127	215½	2231 2336	2138 2150	4369 4486
KS10916 KE10916	127	215½	2235 2341	2142 2153	4377 4494

★ Dimensions with std equipment, unloaded.

● Illustration shows 16 model rear end/lift gate.

March 15, 1971

→ Indicates Change

Conventional Gasoline—10: Page 15

C10 SERIES SUBURBAN CARRYALLS

STANDARD EQUIPMENT

Air Cleaner: Oiled-paper element

Axle, Front: Independent; capacity 2700 lb

Axle, Rear: Hypoid semi-floating type; ratio 3.73; capacity 3500 lb

→ **Battery:** 12-volt; side terminal connectors
 CS10: 54-plate; capacity 45 amp-hr
 CE10: 66-plate; capacity 61 amp-hr

Bodies: See *Model Options and Cabs, Bodies & Colors section*

Brakes, Service: Hydraulic; vacuum power; self-adjusting; dual system
 Front: Single-piston caliper disc type, 11.86" rotor
 Rear: Drum and shoe type; size—11" x 2"
 Rear brake area: drum 138.2 sq in; lining 84.4 sq in

Brake, Parking: Cable to rear wheels; area 84.4 sq in; foot operated

Bumpers: Front & rear; painted

Carburetor: CS10: single-barrel downdraft
 CE10: two-barrel downdraft

Clutch: CS10: diameter 10"; area 100 sq in
 CE10: diameter 11"; area 124 sq in

Cooling: CS10: 1¼" radiator core, cross-flow type; 446-sq-in area; 15-lb pressure cap
 CE10: 1¼" radiator core, cross-flow type; 480-sq-in area; 15-lb pressure cap

Controls & Instruments: Light switch; windshield wiper-washer switch; headlight beam control; speedometer; odometer; fuel gauge. Lights for generator, oil pressure, engine temperature, brake warning, direction signals and high beam indicator. Ignition switch with accessory position. Direction signal switch with freeway lane-change position. Hazard warning switch

Doors, Rear:
 06 models: Two; side-hinged
 16 models: Tail/lift gate

Doors, Side: Three; two right & one left

Emission Control Equipment: See engine & clutch section for types used

Engine: CS10: 250 Six
 Gross horsepower..... 145 @ 4200 rpm
 Net horsepower..... 110 @ 4000 rpm
 Gross torque, lb-ft..... 230 @ 1600 rpm
 Net torque, lb-ft..... 185 @ 1600 rpm

CE10: 307 V8
 Gross horsepower..... 200 @ 4600 rpm
 Net horsepower..... 135 @ 4000 rpm
 Gross torque, lb-ft..... 300 @ 2400 rpm
 Net torque, lb-ft..... 235 @ 2400 rpm

Exhaust System: Single; fully aluminized; unitized muffler-tailpipe

Filter, Fuel: Plastic mesh in fuel tank
 CS10: Paper type in carburetor
 CE10: Sintered bronze in carburetor

Filter, Oil: Full-flow; 1-quart; throwaway type

Frame: 39,000-lb-test steel; section modulus 2.98

Fuel Pump: Mechanically actuated diaphragm

Generator: 37-amp Delcotron

GVW Plate: See GVW Selector

Heater & Defroster: Deluxe-Air

Lights & Reflectors: Two 7" Power Beam headlights; two Class A front combination parking/direction signals; two Class A rear combination tail/stop/direction signals; two front & two rear side marker combination lights & reflectors; two backup: one license; instrument panel & dome. Front side marker lights flash with turn signals

Mirror, Rearview: Exterior chrome RH & LH 4½" x 6" head with fixed arm and inside 10" vinyl-edged prismatic

Seat: Full-width bench; front only; vinyl trim

Seat Belts: Includes retractors, driver & passenger

Shock Absorbers: Front & rear; piston diameter 1"

Springs, Front: Coil; capacity 1350 lb each

Springs, Rear: Coil; capacity 1350 lb each

Steering: Ball-gear; ratio 24:1; wheel, oval 17½" x 17", 2-spoke

Tank, Fuel: Inside frame at rear; capacity approximately 21 gal; pressure/vacuum relief cap; anti-overfill

Tires: Five bias-belted ply tubeless G78-15B(4PR) front, single rear and spare

Tools: 2500-lb mechanical jack; wheel wrench

Transmission: 3-speed fully synchronized; steering column gearshift; ratios 2.85, 1.68, 1.00, 2.95 (rev)

Wheels: Five 15" x 6"; attachment 5 studs on 5" circle; spare carrier inside RH cargo area; four painted hubcaps

Windshield Wipers & Washer: Electric; 2-speed wipers

GVW SELECTOR

GVW Rating (lb)	Minimum Equipment Required for GVW Rating		
	Tires, Front	Tires, Rear	Chassis Equipment
4800	G78-15B(4PR) (TL or TB)	G78-15B(4PR) (TL or TB)	Standard
5400	H78-15B(4PR) (TL)	H78-15B(4PR) (TL)	2000-lb ea rear spring
	6.50-16C(6PR) (TB) (TT)	6.50-16C(6PR) (TB) (TT)	

TL—Tubeless TB—Tube type TT—Truck type

K10 SERIES SUBURBAN CARRYALLS

STANDARD EQUIPMENT

Air Cleaner: Oiled-paper element

Axle, Front: Hypoid, ratio 3.73; capacity 3300 lb; 40-degree turn angle; yoke and trunnion universal joints

Axle, Rear: Hypoid semi-floating type; ratio 3.73; capacity 3300 lb

→ **Battery:** 12-volt; side terminal connectors
KS10: 54-plate; capacity 45 amp-hr
KE10: 66-plate; capacity 61 amp-hr

Bodies: See *Model Options and Cabs, Bodies & Colors section*

Brakes, Service: Hydraulic; vacuum power; self-adjusting; dual system

Front: Single-piston caliper disc type, 11.86" rotor

Rear: Drum & shoe type; size—11" x 2"

Rear brake area: drum 138.2 sq in; lining 84.4 sq in

Brake, Parking: Cable to rear wheels; area 84.4 sq in; foot operated

Bumpers: Front & rear, painted

Carburetor: KS10: single-barrel downdraft
KE10: two-barrel downdraft

Clutch: KS10: diameter 10"; area 100 sq in
KE10: diameter 11"; area 124 sq in

Cooling: KS10: 1¼" radiator core, cross-flow type; 446-sq-in area; 15-lb pressure cap
KE10: 1¼" radiator core, cross-flow type; 480-sq-in area; 15-lb pressure cap

Controls & Instruments: Windshield wiper-washer switch; light switch; headlight beam control; speedometer; odometer; fuel gauge. Lights for generator, oil pressure, engine temperature, brake warning, direction signals and high beam indicator. Ignition switch with accessory position. Direction signal switch with freeway lane-change position. Hazard warning switch

Doors, Rear:

06 models: Two; side-hinged

16 models: Tail/lift gate

Doors, Side: Three; two right & one left

Emission Control Equipment: See engine & clutch section for types used

Engine: KS10: 250 Six

Gross horsepower..... 145 @ 4200 rpm

Net horsepower..... 110 @ 4000 rpm

Gross torque, lb-ft..... 230 @ 1600 rpm

Net torque, lb-ft..... 185 @ 1600 rpm

KE10: 307 V8

Gross horsepower..... 200 @ 4600 rpm

Net horsepower..... 135 @ 4000 rpm

Gross torque, lb-ft..... 300 @ 2400 rpm

Net torque, lb-ft..... 235 @ 2400 rpm

Exhaust System: Single; fully aluminized; unitized muffler-tailpipe

Filter, Fuel: Plastic mesh in fuel tank

KS10: Paper type in carburetor

KE10: Sintered bronze in carburetor

Filter, Oil: Full-flow; 1-quart; throwaway type

Frame: 39,000-lb-test steel; section modulus 3.48

Fuel Pump: Mechanically actuated diaphragm

Generator: 37-amp Delcotron

GVW Plate: See *GVW Selector*

Heater & Defroster: Deluxe-Air

Lights & Reflectors: Two 7" Power Beam headlights; two Class A front combination parking/direction signals; two Class A rear combination tail/stop/direction signals; two front & two rear side marker combination lights & reflectors; two backup; one license; instrument panel & dome. Front side marker lights flash with turn signals

Mirror, Rearview: Exterior chrome RH & LH 4½" x 6" head with fixed arm and inside 10" vinyl-edged prismatic

Seat: Full-width bench; front only; vinyl trim

Seat Belts: Driver & passenger. Includes retractors

Shock Absorbers: Front & rear; piston diameter 1"

Springs, Front: Tapered-leaf; capacity 1450 lb each

Springs, Rear: Two-stage, combination multi-leaf & tapered-leaf; capacity 1800 lb each

Steering: Ball-gear, ratio 24:1; wheel, oval 17½" x 17", 2-spoke

Tank, Fuel: Inside frame at rear; capacity approx 21 gal; pressure/vacuum relief cap; anti-overfill

Tires: Five bias-belted ply tubeless G78-15B(4PR) front, single rear and spare

Tools: 2500-lb mechanical jack; wheel wrench

Transfer Case: New Process 205, 2-speed; ratios 1.96 and 1.00; power take-off opening on left side, single control lever

Transmission: 3-speed fully synchronized; steering column gearshift; ratios 3.03, 1.75, 1.00, 3.02 (rev)

Wheels: Five 15" x 6.0"; attachment, 6 studs on 5½" circle; spare carrier inside RH cargo area

Windshield Wipers & Washer: Electric; 2-speed wipers

GVW SELECTOR

GVW Rating (lb)	Minimum Equipment Required for GVW Rating		
	Tires, Front	Tires, Rear	Chassis Equipment
5200	G78-15B(4PR) (TL or TB)	G78-15B(4PR) (TL or TB)	Standard
5800	H78-15B(4PR) (TL)	H78-15B(4PR) (TL)	
	6.50-16C(6PR) (TB) (TT)	6.50-16C(6PR) (TB) (TT)	

TL—Tubeless

TB—Tube type

TT—Truck type

10 SERIES POWER TEAMS SUBURBAN CARRYALL

C10 SERIES

ENGINE	TRANSMISSION	AXLE RATIOS	
		STD	OPT
250 Six 292 Six	Chevrolet 3-Speed	3.73	3.07; 4.11
	Chevrolet CH465 4-Speed	3.73	3.07; 4.11
250 Six	Powerglide	3.73	4.11
250 Six 292 Six	Turbo Hydra-matic	3.73	3.07; 4.11
307 V8	Chevrolet 3-Speed	3.73	3.07; 4.11
	Chevrolet CH465 4-Speed	3.07	3.73; 4.11
	Powerglide	3.73	4.11
	Turbo Hydra-matic	3.07	3.73; 4.11
350 V8	Chevrolet 3-Speed H.D.	3.07	3.73; 4.11
	Chevrolet CH465 4-Speed	3.07	3.73; 4.11
	Turbo Hydra-matic	3.07	3.73; 4.11
400 V8	Chevrolet 3-Speed H.D.	3.07	—
	Turbo Hydra-matic	3.07	—

K10 SERIES

ENGINE	TRANSMISSION	TRANSFER CASE	AXLE RATIOS	
			STD	OPT
250 Six 292 Six	Chevrolet 3-Speed H.D.	New Process 205	3.73	—
	Chevrolet CH465 4-Speed		3.73	—
	Turbo Hydra-matic		3.73	—
307 V8	Chevrolet 3-Speed H.D.	New Process 205	3.73	—
	Chevrolet CH465 4-Speed		3.73	—
	Turbo Hydra-matic		3.73	—
350 V8	Chevrolet 3-Speed H.D.	New Process 205	3.07	3.73
	Chevrolet CH465 4-Speed		3.07	3.73
	Turbo Hydra-matic		3.07	3.73

OPTIONAL ENGINE RATINGS

CS/KS10 with 292 Six

Gross Horsepower.....165 @ 4000 rpm
 Net Horsepower.....125 @ 3600 rpm
 Gross Torque, lb-ft.....270 @ 1600 rpm
 Net Torque, lb-ft.....225 @ 2400 rpm

CE/KE10 with 350 V8

Gross Horsepower.....250 @ 4600 rpm
 Net Horsepower.....170 @ 3600 rpm
 Gross Torque, lb-ft.....350 @ 3000 rpm
 Net Torque, lb-ft.....310 @ 2400 rpm

CE10 with 400 V8

Gross Horsepower.....300 @ 4800 rpm
 Net Horsepower.....240 @ 4400 rpm
 Gross Torque, lb-ft.....400 @ 3200 rpm
 Net Torque, lb-ft.....340 @ 3200 rpm

C10 SERIES—2-WHEEL DRIVE SUBURBAN CARRYALL K10 SERIES—4-WHEEL DRIVE SUBURBAN CARRYALL

1971 MODELS WITH STANDARD EQUIPMENT

Model Number and Description	Wheel-base	Factory D & H	List Price	Mfr's Suggested Retail Price*	Destination Charge & Group Number	Total
→ 6-Cylinder 145-hp High Torque 250 Engine						
CS10906 Suburban Carryall (Panel Doors)	127"	\$190.00	\$3398.00	\$3588.00	15.....	
KS10906 Suburban Carryall (Panel Doors)	127"	223.00	4001.00	4224.00	16.....	
CS10916 Suburban Carryall (End Gate)	127"	192.00	3428.00	3620.00	15.....	
KS10916 Suburban Carryall (End Gate)	127"	225.00	4031.00	4256.00	16.....	
→ 8-Cylinder 200-hp High Torque Engine						
CE10906 Suburban Carryall (Panel Doors)	127"	196.00	3513.00	3709.00	15.....	
KE10906 Suburban Carryall (Panel Doors)	127"	229.00	4116.00	4345.00	16.....	
CE10916 Suburban Carryall (End Gate)	127"	198.00	3543.00	3741.00	15.....	
KE10916 Suburban Carryall (End Gate)	127"	231.00	4146.00	4377.00	16.....	

* Manufacturer's Suggested Retail Prices do not include state and local taxes, license fees, options or accessories.

OPTIONS AND ACCESSORIES WHEN INSTALLED BY CHEVROLET

Description	Option Number	Factory D & H	List Price	Mfr's Suggested Retail Delivered Price*
-------------	---------------	---------------	------------	---

MODEL OPTION

Custom Deluxe: See Exterior and Interior Color Chart for interior colors. Includes vent window and windshield moldings; bright control knob trim; fender nameplates; color-keyed floor mat; white hardboard headlining; sidewall trim panels; spare wheel cover; cigar lighter; special insulation; dual horns; front door dome lamp switches; bright glove box nameplate and dome lamp bezel.

When standard front seat is specified. Also includes full-depth foam seat with cloth trim.

When optional center or rear seats are not ordered	Z62	\$ 8.90	\$167.00	\$175.90
When optional center seat is ordered. Also includes matching cloth center seat	Z62	9.45	177.00	186.45
When optional center and rear seats are ordered. Also includes matching cloth center and rear seats	Z62	9.95	187.00	196.95
When bucket seats or when custom deluxe front seat is ordered				
When optional center or rear seats are not ordered	Z62	6.80	127.00	133.80
When optional center seat is ordered	Z62	6.80	127.00	133.80
When optional center and rear seat is ordered. Also includes color-keyed rear floor mat	Z62	7.85	147.00	154.85

POWER TEAMS AND AXLES

Engines:				
292 Six. CS-KS10 models only. Not available when Powerglide transmission is ordered. Includes 11" clutch	L25	4.80	90.00	94.80
350 V8. CE-KE10 models only. Includes 4-barrel carburetor, 3.07 ratio rear axle and 12" coil clutch	LS9	2.25	42.00	44.25
400 V8. CE10 models only. Not available when Powerglide or Chevrolet 4-speed transmission is ordered. Includes 4-barrel carburetor, dual exhausts, 12" coil clutch, 3.07 ratio rear axle with standard or Turbo Hydra-matic transmission	L47	8.80	165.00	173.80
Liquid Petroleum Gas Conversion. C10 models only. Not available when automatic transmission, HD clutch, 307 or 400 engine is ordered. Includes internal modifications of valves, compression ratio and heat shield only	LS6	4.80	90.00	94.80
Transmissions:				
Powerglide. C10 models with standard engine only. Not available when 3.07 or 3.73 ratio rear axle is specified with 6.50-16 tires. Includes HD radiator	M35	10.65	200.00	210.65
Turbo Hydra-matic. Includes HD radiator. CE10 models also includes 3.07 ratio rear axle				
Without 400 engine	M49	12.25	230.00	242.25
With 400 engine	M49	12.80	240.00	252.80
→ Chevrolet 4-Speed. Not available when 400 engine is ordered. CE10 models include 3.07 ratio rear axle	M20	5.60	105.00	110.60

* State and local taxes not included.

→ Indicates Change

C-K10 SERIES SUBURBAN CARRYALL

OPTIONS AND ACCESSORIES WHEN INSTALLED BY CHEVROLET

Description	Option Number	Factory D & H	List Price	Mfr's Suggested Retail Delivered Price [◇]
Axles, Rear:				
3.07 Ratio. C10 models only. Not available when Powerglide transmission is ordered. Included when Turbo Hydra-matic or Chevrolet 4-speed transmission is ordered with 307 engine or when 3-speed or Turbo Hydra-matic transmission is ordered with 400 engine. Also included when 350 engine is ordered.	H01	\$.65	\$12.00	\$12.65
3.73 Ratio. Available only when 350 engine is ordered. Also available on C10 models when Turbo Hydra-matic or Chevrolet 4-speed transmission is ordered with 307 engine.	H05	.65	12.00	12.65
4.11 Ratio. C10 models only. Not available when 400 engine is ordered.				
With 250, 292 or 307 engine	H04	.65	12.00	12.65
With 350 engine				
Without air conditioning	H04	.80	14.40	15.20
With air conditioning	H04	.65	12.00	12.65
Positraction	G80	3.30	62.00	65.30

OTHER OPTIONS

Air Cleaner: Oil-bath. Capacity 1 quart. Not available on CE-KE10 models when 350 or 400 engine is ordered.	K48	.55	10.00	10.55
Air Conditioning, Interior Roof Mounted: V8 model only. Available only when custom deluxe is ordered. Includes HD radiator and 42-amp generator.	C69	33.25	625.00	658.25
Batteries: 12-volt				
→ Auxiliary. 53-amp-hr, 9-plate	TP2	2.40	45.00	47.40
Heavy-duty. 80-amp-hr, 15-plate	T60	.90	16.00	16.90
Belts, Seat: Installed for third passenger				
Front Seat. Not available when bucket seats are ordered.	AM3	.35	6.50	6.85
Center Seat.	A68	.35	6.50	6.85
Center and Rear Seats.	A68	.70	13.00	13.70
Bumpers: Chromed. Front and rear	V37	1.60	30.00	31.60
Caps, Hub: Chromed. C10 models only	P03	.55	10.00	10.55
Clutch, Heavy-Duty: Diameter 11". CS-KS10 models only. Included when Chevrolet 4-speed transmission or 292 engine is ordered.	M01	.35	6.50	6.85
Cooling: HD radiator only. Included when air conditioning or automatic transmission is ordered.	V01	1.35	25.00	26.35
Gauges:				
Ammeter, temperature and oil pressure.	Z53	.65	12.00	12.65
Tachometer, ammeter, temperature and oil pressure.	U16	2.95	55.00	57.95
Generators:				
42-amp Delcotron. Included when air conditioning is ordered	K79	1.20	22.00	23.20
61-amp Delcotron.	K76	1.60	30.00	31.60
Glass, Soft-Ray: All windows	A11	1.55	29.00	30.55

◇ State and local taxes not included.

→ Indicates Change

C-K10 SERIES SUBURBAN CARRYALL

OPTIONS AND ACCESSORIES WHEN INSTALLED BY CHEVROLET

Description	Option Number	Factory D & H	List Price	Mfr's Suggested Retail Delivered Price [Ⓞ]
Guards, Door Edge	B93	\$.45	\$ 8.00	\$ 8.45
Hooks, Towing: Two, front. Not available with chromed bumper ..	V76	1.00	18.00	19.00
Hubs, Front Free-Wheeling: K10 models only. Manual control at hubs.	F76	3.90	73.00	76.90
Lamps: Roof Marker: Five	U01	1.35	25.00	26.35
Lighter, Cigar: Included when custom deluxe is ordered ..	U37	.30	5.00	5.30
Mirrors, Exterior: Replacing standard LH and RH mirrors				
<i>Below-Eye-Line type</i>				
7.5" x 10.5" painted	D29	1.05	19.50	20.55
7.5" x 10.5" stainless steel	DG4	1.90	35.00	36.90
Camper type				
Painted	DF1	1.05	19.50	20.55
Stainless steel	DF2	2.65	49.00	51.65
Moldings, Custom:				
<i>Belt Line.</i> Includes bright fuel filler cap	BX1	1.90	35.00	36.90
<i>Lower Fender, Door and Body.</i> Includes bright fuel filler cap ..	BX2	2.15	40.00	42.15
Paints, Exterior: See Color and Trim Chart				
<i>Solid color</i>		N.C.	N.C.	N.C.
<i>Conventional two-tone.</i> With white secondary color		2.15	40.00	42.15
<i>Special two-tone.</i> With white upper and lower secondary colors. Available only when custom lower moldings are ordered		3.20	60.00	63.20
Plate: Serial Number (State of Pennsylvania "K" Plate). Available on C10 models only when 2000-lb each HD rear springs are ordered	Z55	N.C.	N.C.	N.C.
Radios: Pushbutton control. Includes manual front antenna				
AM	U63	3.50	65.00	68.50
AM/FM	U69	7.55	141.00	148.55
Seats, Front: See Exterior and Interior Color Chart.				
Custom Deluxe Vinyl, Full-Width. Available in parchment trim only. Includes front seat area carpeting.				
When optional rear seats are not ordered	AS2	3.65	68.00	71.65
When center seat is ordered. Also includes center seat area carpeting ..	AS2	6.30	118.00	124.30
When center and rear seats are ordered. Also includes center and rear seat area carpeting	AS2	8.45	158.00	166.45
Bucket, Driver and Passenger. Available in parchment trim only. Includes front seat area floor carpeting and center console.				
When optional rear seats are not ordered	A50	6.55	123.00	129.55
When center seat is ordered. Also includes center seat area carpeting ..	A50	9.25	173.00	182.25
When center and rear seats are ordered. Also includes center and rear seat area carpeting	A50	11.35	213.00	224.35
Seats, Rear: Seat trim always matches the front seats whether standard or optional. The price of matching seat trim is included when custom deluxe or optional front seats are ordered. Includes RH coat hook.				
Center Seat. Available only when H78-15/B or truck-type tires are ordered. Includes HD front and rear springs on C10 models only, LH and RH armrests and seat belts	AS3	6.00	112.00	118.00
Center and Rear Seats. Available only when H78-15/B or truck-type tires are ordered. Includes HD front and rear springs on C10 models only, LH and RH armrests and seat belts	A80	11.50	216.00	227.50
Shock Absorbers:				
<i>Front and Rear.</i> Heavy-duty	F51	.80	15.00	15.80
<i>Rear.</i> Heavy-duty	G68	.45	8.00	8.45
<i>Superlift Rear.</i> C10 models only	G66	2.40	45.00	47.40
Springs, Heavy-Duty:				
<i>Front</i>				
Capacity 1500-lb each. C10 models only. Included when center or rear seat is ordered	F60	.35	6.00	6.35
Capacity 1750-lb each. K10 models only	F60	1.65	31.00	32.65
<i>Rear.</i> Capacity 2000-lb each. C10 models with HD front springs only. Included when center or rear seats are ordered	G50	1.00	18.00	19.00
<i>Auxiliary Rear.</i> Capacity 500-lb each. C10 models only	G60	1.55	29.00	30.55
Stabilizer, Front: C10 models only	F59	1.00	18.00	19.00
Steering, Power:				
C10 models only	N40	6.65	125.00	131.65
K10 models only	N40	7.45	140.00	147.45
Steering Wheel, Comfortilt: Available only when optional transmission is ordered	N33	2.95	55.00	57.95
Switches, Dome Lamp: Front doors. Included when custom deluxe is ordered	C80	.25	4.00	4.25
Throttle Control: Manual	K31	.75	14.00	14.75
Tires: See following page				
Wheel Covers, Bright Metal: C10 models with G78-15 or H78-15 tires only	PO1	1.35	25.00	26.35

Ⓞ State and local taxes not included.

C-K10 SERIES SUBURBAN CARRYALL

TUBE-TYPE TIRES (Factory Installed)

Tire Size and Type			Rim Width Included In Tire Option	Option Number	Factory D & H	List Price	Mfr's Suggest Retail Delivered Price [⊕]
All tires have black sidewalls except as indicated. Note: Front and rear tires must be of the same construction, rim width and diameter. K10 models require use of same tread type on front and rear wheels.							
678-15/B							
(Pass. type) — Highway Bias Belted Ply	(5) Front, rear & spare	6.00	RL5	N.C.	\$10.00	\$10.00	
	(2) Front; C10 only	6.00	RL5	N.C.	4.00	4.00	
	(3) Front & spare; C10 only	6.00	RL5	N.C.	6.00	6.00	
—On-Off Road Bias Belted Ply							
	(5) Front, rear & spare; K10 only	6.00	RL4	\$.75	20.50	21.25	
	(2) Rear; C10 only	6.00	RL4	.30	8.20	8.50	
	(3) Rear & spare; C10 only	6.00	RL4	.45	12.30	12.75	
6.50-16/C							
(Pass. type) — Highway Original Equipment	(5) Front, rear & spare	5.00	R61	1.25	31.50	32.75	
	(2) Front; C10 only	5.00	R61	.50	12.60	13.10	
	(3) Front & spare; C10 only	5.00	R61	.75	18.90	19.65	
—On-Off Road Original Equipment							
	(5) Front, rear & spare; K10 only	5.00	R69	2.25	49.00	51.25	
	(2) Rear; C10 only	5.00	R69	.90	19.60	20.50	
	(3) Rear & spare; C10 only	5.00	R69	1.35	29.40	30.75	
6.50-16/C (6PR) Maximum Tire Capacity (Each)—Front (1610) Rear (1610)							
(Truck type) — Highway Nylon	(5) Front, rear & spare	5.00	R65	3.25	71.50	74.75	
	(2) Front; C10 only	5.00	R65	1.30	28.60	29.90	
	(3) Front & spare; C10 only	5.00	R65	1.95	42.90	44.85	
—On-Off Road Nylon							
	(5) Front, rear & spare; K10 only	5.00	R64	6.50	124.00	130.50	
	(2) Rear; C10 only	5.00	R64	2.60	49.60	52.20	
	(3) Rear & spare; C10 only	5.00	R64	3.90	74.40	78.30	

TUBELESS TIRES (Factory Installed)

678-15/B							
(Pass. type) — Highway Bias Belted Ply	(5) Front, rear & spare	6.00	Std	N.C.	N.C.	N.C.	
	(5) Front, rear & spare (White Stripe)	6.00	PUS	1.30	31.00	32.30	
—On-Off Road Bias Belted Ply							
	(5) Front, rear & spare; K10 only	6.00	RL3	1.00	17.50	18.50	
	(2) Rear; C10 only	6.00	RL3	.40	7.00	7.40	
	(3) Rear & spare; C10 only	6.00	RL3	.60	10.50	11.10	
H78-15/B							
(Pass. type) — Highway Bias Belted Ply	(5) Front, rear & spare	6.00	PV5	1.75	22.50	24.25	
	(2) Front; C10 only	6.00	PV5	.70	9.00	9.70	
	(3) Front & spare; C10 only	6.00	PV5	1.05	13.50	14.55	
	(5) Front, rear & spare (White Stripe)	6.00	PV6	3.10	56.50	59.60	
—On-Off Road Bias Belted Ply							
	(5) Front, rear & spare; K10 only	6.00	RM1	2.75	40.00	42.75	
	(2) Rear; C10 only	6.00	RM1	1.10	16.00	17.10	
	(3) Rear & spare; C10 only	6.00	RM1	1.65	24.00	25.65	

⊕ State and local taxes not included.

C20 SERIES (EXCEPT SUBURBAN CARRYALLS)

STANDARD EQUIPMENT

Air Cleaner: Oiled-paper element
Axle, Front: Independent; capacity 3000 lbs
Axle, Rear: Hypoid full-floating type; ratio 4.57; capacity 5200 lb
Battery: 12-volt; side terminal connectors
 CS20: 54-plate; capacity 45 amp-hr
 CE20: 66-plate; capacity 61 amp-hr
Brakes, Service: Hydraulic; vacuum power; self-adjusting; dual system
 Front: Single-piston caliper disc type, 12.5" rotor
 Rear: Drum and shoe type; size—11" x 2 3/4"
 Rear brake area: drum 190.1 sq in; lining 113.9 sq in
Brake, Parking: Cable to rear wheels; area 113.9 sq in; foot operated
Bumper: Front only; painted
Cabs: See *Model Options and Cabs, Bodies & Colors section*
Carburetor: CS20: single-barrel downdraft
 CE20: two-barrel downdraft
Clutch: CS20: diameter 10"; area 100 sq in
 CE20: diameter 11"; area 124 sq in
Cooling: CS20: 1 1/4" radiator core, cross-flow type; 446-sq-in area; 15-lb pressure cap
 CE20: 1 1/4" radiator core, cross-flow type; 480-sq-in area; 15-lb pressure cap
Controls & Instruments: Light switch; windshield wiper-washer switch; headlight beam control; speedometer; odometer; fuel gauge. Lights for generator, oil pressure, engine temperature, brake warning, direction signals and high beam indicator. Ignition switch with accessory position. Direction signal switch with freeway lane-change position. Hazard warning switch
Emission Control Equipment: See Engine & Clutch section for types used
Engine:
 CS20: 250 Six
 Gross horsepower..... 145 @ 4200 rpm
 Net horsepower..... 110 @ 4000 rpm
 Gross torque, lb-ft..... 230 @ 1600 rpm
 Net torque, lb-ft..... 185 @ 1600 rpm
 CE20: 307 V8
 Gross horsepower..... 215 @ 4800 rpm
 Net horsepower..... 135 @ 4000 rpm
 Gross torque, lb-ft..... 305 @ 2800 rpm
 Net torque, lb-ft..... 230 @ 2000 rpm
Exhaust System: Single; fully aluminized; unitized muffler-tailpipe

Filter, Fuel: Plastic mesh in fuel tank; paper type in carburetor
Filter, Oil: Full-flow; 1-quart; throwaway type
Frame: 39,000-lb-test steel
 All models except Longhorn: section modulus 3.71
 Longhorn: section modulus 5.05
Fuel Pump: Mechanically actuated diaphragm
Generator: 37-amp Delco-tron
GVW Plate: See GVW Selector
Heater & Defroster: Deluxe-Air
Lights & Reflectors:
 03 models: Two 7" Power Beam headlights; two Class A front combination parking/direction signals; two Class A rear combination tail/stop/direction signals; two front side marker combination lights and reflectors; two backup; one license; instrument panel & dome. Front side marker lights flash with turn signals
 04 & 34 models: Same as 03 models plus two rear side marker combination lights & reflectors
Mirror, Rearview:
 All models—Inside 10" vinyl-edged prismatic
 03 models—Exterior painted RH & LH 5 1/2" x 7 1/2" head with folding arm
 04, 34 models—Exterior chrome RH & LH 4 1/2" x 6" head with fixed arm
Seat: Full-width; vinyl trim
Seat Belts: Includes retractors; driver & passenger
Shock Absorbers: Front & rear; piston diameter 1"
Springs, Front: Coil; capacity 1500 lb
Springs, Rear:
 All models except Longhorn: 2-stage coil; capacity 2000 lb each
 Longhorn: Two-stage; combination multi-leaf & tapered-leaf; capacity 2000 lb each
Steering: Ball-gear, ratio 24:1; wheel, oval rim 17 1/2" x 17", 2-spoke
Tank, Fuel: Back of seat in cab; capacity approx 21 gallons
Tires: Four tubeless 8.75-16.5C(6PR) nylon front and single rear
Tools: 4000-lb mechanical jack; wheel wrench
Transmission: 3-speed fully synchronized; steering column gearshift; ratios 2.85, 1.68, 1.00, 2.95 (rev)
Wheels: Five 16.5 x 6.0; attachment, 8 studs on 6 1/2" circle; spare carrier under frame; 4 painted hubcaps
Windshield Wipers & Washer: Electric; 2-speed wipers

GVW SELECTOR

GVW Rating (lb)	Minimum Equipment Required for GVW Rating		
	Tires, Front	Tires, Rear	Chassis Equipment
6200	8.75-16.5C(6PR) (TL)	8.75-16.5C(6PR) (TL)	Standard
	7.50-16C(6PR) (TB)	7.50-16C(6PR) (TB)	
6700	8.75-16.5C(6PR) (TL)	8.75-16.5D(8PR) (TL)	3000-lb ea rear spring*
	7.50-16C(6PR) (TB)	7.50-16D(8PR) (TB)	
7500	9.50-16.5D(8PR) (TL)	9.50-16.5D(8PR) (TL)	3000-lb ea rear spring*
	7.50-16E(10PR) (TB)	7.50-16E(10PR) (TB)	

*2750-lb ea rear spring on Longhorn, Model 21034

TL—Tubeless

TB—Tube type

March 15, 1971

→Indicates Change

Conventional Gasoline—20: Page 5

K20 SERIES (EXCEPT SUBURBAN CARRYALLS)

STANDARD EQUIPMENT

Air Cleaner: Oiled-paper element
Axle, Front: Hypoid; ratio 4.55; capacity 3500 lb; yoke and trunnion universal joints
Axle, Rear: Hypoid full-floating type; ratio 4.57; capacity 5200 lb
Battery: 12-volt; side terminal connectors
 KS20: 54-plate; capacity 45 amp-hr
 KE20: 66-plate; capacity 61 amp-hr
Brakes, Service: Hydraulic; vacuum power; self-adjusting; dual system
 Front: Single-piston caliper disc type, 12.5" rotor
 Rear: Drum and shoe type; 12" x 2"
 Rear brake area: drum 150.8 sq in; lining 89.0 sq in
Brake, Parking: Cable to rear wheels; area 89.0 sq in; foot operated
Bumper: Front only, painted
Cabs: See *Model Options and Cabs, Bodies & Colors section*
Carburetor: KS20: single-barrel downdraft
 KE20: two-barrel downdraft
Clutch: KS20: diameter 10"; area 100 sq in
 KE20: diameter 11"; area 124 sq in
Cooling: KS20: 1 1/4" radiator core, cross-flow type; 446-sq-in area; 15-lb pressure cap
 KE20: 1 1/4" radiator core, cross-flow type; 480-sq-in area; 15-lb pressure cap
Controls & Instruments: Light switch; windshield wiper-washer switch; headlight beam control; speedometer; odometer; fuel gauge. Lights for generator, oil pressure, engine temperature, brake warning, direction signals and high beam indicator. Ignition switch with accessory position. Direction signal switch with freeway lane-change position. Hazard warning switch
Emission Control Equipment: See engine & clutch section for types used
Engine: KS20: 250 Six
 Gross horsepower 145 @ 4200 rpm
 Net horsepower 110 @ 4000 rpm
 Gross torque, lb-ft. 230 @ 1600 rpm
 Net torque, lb-ft. 185 @ 1600 rpm
 KE20: 307 V8
 Gross horsepower 215 @ 4800 rpm
 Net horsepower 135 @ 4000 rpm
 Gross torque, lb-ft. 305 @ 2800 rpm
 Net torque, lb-ft. 230 @ 2000 rpm
Exhaust System: Single; fully aluminized; unitized muffler-tailpipe

Filter, Fuel: Plastic mesh in fuel tank; paper type in carburetor
Filter, Oil: Full-flow; 1-quart; throwaway type
Frame: 39,000-lb-test steel; section modulus 3.48
Fuel Pump: Mechanically actuated diaphragm
Generator: 37-amp Delcotron
GVW Plate: See GVW Selector
Heater & Defroster: Deluxe-Air
Lights & Reflectors:
 03 models: Two 7" Power Beam headlights; two Class A front combination parking/direction signals; two Class A rear combination tail/stop/direction signals; two front side marker combination lights and reflectors; two backup; one license; instrument panel & dome. Front side marker lights flash with turn signals
 04 & 34 models: Same as 03 models plus two rear side marker combination lights & reflectors
Mirror, Rearview: All models; inside 10" vinyl-edged prismatic.
 03 models: Exterior painted RH & LH 5 1/2" x 7 1/2" head with folding arm
 04, 34 models: Exterior chrome 4 1/2" x 6" head with fixed arm
Seat: Full-width; vinyl trim
Seat Belts: Driver & passenger; includes retractors
Shock Absorbers: Front & rear; piston diameter 1"
Springs, Front: Tapered-leaf; capacity 1600 lb each
Springs, Rear: Two-stage; combination multi-leaf and tapered-leaf; capacity 1900 lb each
Steering: Ball-gear, ratio 24:1; wheel, oval 17 1/2" x 17", 2-spoke
Tank, Fuel: Back of seat in cab; capacity approx 21 gallons
Tires: Four tubeless 8.75-16.5C(6PR) nylon front, single rear
Tools: 4000-lb mechanical jack; wheel wrench
Transfer Case: New Process 205, 2-speed; ratios 1.96 & 1.00, power take-off opening at left side, single control lever
Transmission: 3-speed fully synchronized; steering column gearshift; ratios 3.03, 1.75, 1.00, 3.02 (rev)
Wheels: Five 16.5" x 6.0"; attachment, 8 studs on 6 1/2" circle; spare carrier under frame
Windshield Wipers & Washer: Electric; 2-speed wipers

GVW SELECTOR

GVW Rating (lb)	Minimum Equipment Required for GVW Rating		
	Tires, Front	Tires, Rear	Chassis Equipment
6400	8.75-16.5C(6PR) (TL)	8.75-16.5C(6PR) (TL)	Standard
	7.50-16C(6PR) (TB)	7.50-16C(6PR) (TL)	
7200	8.75-16.5C(6PR) (TL)	8.75-16.5D(8PR) (TL)	2500-lb ea rear spring
	7.50-16C(6PR) (TB)	7.50-16D(8PR) (TB)	
7500	9.50-16.5D(8PR) (TL)	9.50-16.5D(8PR) (TL)	2500-lb ea rear spring
	7.50-16E(10PR) (TB)	7.50-16E(10PR) (TB)	

TL—Tubeless TB—Tube type

NOTES

20 SERIES POWER TEAMS (EXCEPT SUBURBAN CARRYALL)

→ C20 SERIES

ENGINE	TRANSMISSION	AXLE RATIOS			
		Chevrolet Rear Axle		Dana Rear Axle w/Opt. Leaf Suspension or 400V8	
		Std.	Opt.	Included	Opt.
250 Six	Chevrolet 3-Speed	4.57	4.10	4.56	4.10
	Chevrolet CH465 4-Speed	4.57	4.10	4.56	4.10
	Powerglide	4.57	4.10	4.56	4.10
	Turbo Hydra-matic	4.57	4.10	4.56	4.10
292 Six 307 V8	Chevrolet 3-Speed	4.57	4.10	4.56	4.10
	Chevrolet CH465 4-Speed	4.10	4.57	4.10	—
	Turbo Hydra-matic	4.10	4.57	4.10	—
307 V8	Powerglide	4.57	4.10	4.56	4.10
350 V8	Chevrolet 3-Speed	4.57	4.10	4.56	4.10
	Chevrolet CH465 4-Speed	4.10	4.57	4.10	—
	New Process 435CR 4-Speed	4.57	4.10	4.56	4.10
	Turbo Hydra-matic	4.10	4.57	4.10	—
400 V8	Chevrolet 3-Speed	—	—	3.54	—
	Chevrolet CH465 4-Speed	—	—	3.54	—
	Turbo Hydra-matic	—	—	3.54	4.10†

†4.10 ratio available with standard (Longhorn) or optional leaf rear spring suspension only.

→ K20 SERIES

ENGINE	TRANSMISSION	TRANSFER CASE	AXLE RATIOS	
			STD	OPT
250 Six 292 Six	Chevrolet 3-Speed H.D.	New Process 205	4.57	—
	Chevrolet CH465 4-Speed		4.57	—
	Turbo Hydra-matic		4.57	—
307 V8	Chevrolet 3-Speed H.D.		4.57	—
	Chevrolet CH465 4-Speed		4.57	—
	Turbo Hydra-matic		4.57	—
350 V8	Chevrolet 3-Speed H.D.		4.57	—
	Chevrolet CH465 4-Speed		4.10	—
	Turbo Hydra-matic		4.10	—

OPTIONAL ENGINE RATINGS

CS, KS20 with 292 Six

Gross Horsepower.....165 @ 4000 rpm
 Net Horsepower.....125 @ 3600 rpm
 Gross Torque, lb-ft.....270 @ 1600 rpm
 Net Torque, lb-ft.....225 @ 2400 rpm

CE, KE20 with 350 V8

Gross Horsepower.....250 @ 4600 rpm
 Net Horsepower.....170 @ 3600 rpm
 Gross Torque, lb-ft.....350 @ 3000 rpm
 Net Torque, lb-ft.....310 @ 2400 rpm

CE20 with 400 V8

Gross Horsepower.....300 @ 4800 rpm
 Net Horsepower.....240 @ 4400 rpm
 Gross Torque, lb-ft.....400 @ 3200 rpm
 Net Torque, lb-ft.....340 @ 3200 rpm

**C20 SERIES—GASOLINE—2—WHEEL DRIVE (6200-lb—7500-lb GVW)
K20 SERIES—GASOLINE—4—WHEEL DRIVE (6400-lb—7500-lb GVW) X
1971 MODELS WITH STANDARD EQUIPMENT**

Model Number and Description	Wheel-base	Factory D & H	List Price	Mfr's Suggested Retail Price*	Destination Charge & Group Number	Total
→ 6-Cylinder 145-hp High Torque 250 Engine						
CS20903 Chassis-Cab (54' Cab-to-Axle)	127"	\$211.00	\$2676.00	\$2887.00	24.....
CS20904 Pickup—Stepside (8-ft)	127"	223.00	2825.00	3048.00	20.....
CS20934 Pickup—Fleetside (8-ft)	127"	223.00	2825.00	3048.00	20.....
CS21034 Pickup—Fleetside (8½-ft)	133"	228.00	2885.00	3113.00	20.....
KS20903 Chassis-Cab (54' Cab-to-Axle)	127"	264.00	3377.00	3641.00	21.....
KS20904 Pickup—Stepside (8-ft)	127"	276.00	3528.00	3804.00	22.....
KS20934 Pickup—Fleetside (8-ft)	127"	276.00	3528.00	3804.00	22.....
→ 8-Cylinder 215-hp High Torque 307 Engine						
CE20903 Chassis-Cab (54' Cab-to-Axle)	127"	220.00	2791.00	3011.00	24.....
CE20904 Pickup—Stepside (8-ft)	127"	232.00	2940.00	3172.00	20.....
CE20934 Pickup—Fleetside (8-ft)	127"	232.00	2940.00	3172.00	20.....
CE21034 Pickup—Fleetside (8½-ft)	133"	236.00	3000.00	3236.00	20.....
KE20903 Chassis-Cab (54' Cab-to-Axle)	127"	272.00	3492.00	3764.00	21.....
KE20904 Pickup—Stepside (8-ft)	127"	284.00	3643.00	3927.00	22.....
KE20934 Pickup—Fleetside (8-ft)	127"	284.00	3643.00	3927.00	22.....

* Manufacturer's Suggested Retail Prices do not include state and local taxes, license fees, options or accessories.

OPTIONS AND ACCESSORIES WHEN INSTALLED BY CHEVROLET

Description	Option Number	Factory D & H	List Price	Mfr's Suggested Retail Delivered Price
-------------	---------------	---------------	------------	--

MODEL OPTIONS

(See Exterior and Interior Color Charts)

→ Custom Deluxe: Not available when Cheyenne, Cheyenne Super or bucket seats are ordered. Includes bright metal rear window molding; vent window and windshield moldings; cigar lighter; dual horns; bright control knob trim and dome lamp bezel; fender nameplates; full-depth foam seat with cloth trim; door trim panels; color-keyed floor mat; door operated dome lamp switches and special insulation	262		\$ 7.60	\$100.00	\$107.60
Cheyenne: Includes full-depth foam seat with deluxe vinyl trim; carpeting; door trim panels; chromed front bumper; cigar lighter; headliner; cargo area lamp; bright control knob and pedal trim; rear window, vent window and windshield moldings; Cheyenne fender nameplates; bright side marker lamp bezels; dual horns; door operated dome lamp switches and special insulation					
Chassis-Cab or Stepside Pickup models only	284		14.90	196.00	210.90
Fleetside Pickup models only. Also includes body side lower molding and bright fuel filler cap	284		17.95	236.00	253.95
→ Cheyenne Super: Includes full-depth foam seat with cloth trim; carpeting; door trim panels; bright moldings and wood grained trim with Cheyenne Super nameplate on glove box cover; wood grained gauge type instrument cluster; chromed front bumper; cigar lighter; headliner; cargo area lamp; bright control knob and pedal trim; rear window, vent window and windshield moldings; Cheyenne Super fender nameplates; bright side marker lamp bezels; dual horns; door operated dome lamp switches and special insulation					
Chassis-Cab models					
Without 10.00-16.5 tires. Also includes chromed hub caps					
C20 models only	YE9		Will Advise		
K20 models only	YE9		Will Advise		
With 10.00-16.5 tires					
C20 models only	YE9		Will Advise		
K20 models only	YE9		Will Advise		
Stepside Pickup models only. Also includes chromed hub caps					
C20 models only	YE9		Will Advise		
K20 models only	YE9		Will Advise		
Fleetside Pickup models only. Also includes body side, upper and lower moldings plus bright fuel filler cap and tailgate latch					
Without 10.00-16.5 tires. Also includes chromed hub caps					
C20 models only	YE9		Will Advise		
K20 models only	YE9		Will Advise		
With 10.00-16.5 tires					
C20 models only	YE9		Will Advise		
K20 models only	YE9		Will Advise		

⊙ State and local taxes not included.

→ Indicates Change

C-K20 SERIES—GASOLINE

OPTIONS AND ACCESSORIES WHEN INSTALLED BY CHEVROLET

+

Description	Option Number	Factory D & H	List Price	Mfr's Suggested Retail Delivered Price [⊕]
-------------	---------------	---------------	------------	---

POWER TEAMS AND AXLES

Engines:

292 Six, CS-KS20 models with 3-speed, Chevrolet 4-speed or Turbo Hydra-matic transmission only. Includes 11" clutch. CS20 models also includes 4.10 ratio rear axle when Chevrolet 4-speed or Turbo Hydra-matic transmission is ordered	L25	\$ 6.85	\$ 90.00	\$ 96.85
350 V8, CE-KE20 models only. Includes 4-barrel carburetor and 12" coil clutch. Also includes 4.10 ratio rear axle when Chevrolet 4-speed or Turbo Hydra-matic transmission is ordered.	LS9	3.20	42.00	45.20
400 V8, CE20 models with 3-speed, Chevrolet 4-speed or Turbo Hydra-matic transmission only. Includes 3.54 ratio rear axle, 4-barrel carburetor, 12" clutch and dual exhausts	L47	12.55	165.00	177.55
Liquid Petroleum Gas Conversion, C20 models only. Not available when automatic transmission, HD clutch, 307 or 400 engine is ordered. Includes internal modifications of valves, compression ratio and heat shield	L56	6.85	90.00	96.85
Transmissions:				
Powerglide, C20 models with standard engine only. Not available when 4.11 ratio rear axle is specified with 7.50-16 tires. Includes HD radiator	M35	15.20	200.00	215.20
Turbo Hydra-matic. Includes HD radiator				
Without 400 engine. Includes 4.10 ratio rear axle on C20 models when 292, 307 or 350 engine or K20 models when 350 engine is ordered	M49	17.50	230.00	247.50
With 400 engine. Includes 3.54 ratio rear axle	M49	18.25	240.00	258.25
Chevrolet 4-Speed				
C20 models only. Includes 4.10 ratio rear axle when 292, 307 or 350 engine is ordered	M20	8.75	115.00	123.75
K20 models only. Includes 4.10 ratio rear axle when 350 engine is ordered	M20	8.00	105.00	113.00
New Process 435CR 4-Speed Close-Ratio, CE20 models with 350 engine only	M28	11.05	145.00	156.05

Axles, Rear:

WITH STANDARD REAR SPRINGS ONLY

4.10 Ratio, C20 models with Chevrolet 4-speed or Turbo Hydra-matic transmission and 250 engine; 3-speed, New Process 4-speed close-ratio or Powerglide transmission only				
All models except CE21034. Not available when 400 engine is ordered	HB8	.95	12.00	12.95
CE21034 model only. Available only when 400 engine and Turbo Hydra-matic transmission are ordered. Not available when maximum traction rear axle is ordered.	JA1	.95	12.00	12.95
4.57 Ratio, C20 models only. Available only when Chevrolet 4-speed or Turbo Hydra-matic transmission with 292, 307 or 350 engine is ordered	H20	.95	12.00	12.95
NoSPIN. Not available when 400 engine is ordered	G86	9.50	125.00	134.50
Maximum Traction, CE20 models with 400 engine only	G87	9.50	125.00	134.50
C20 MODELS WITH OPTIONAL LEAF-TYPE REAR SPRINGS				
4.10 Ratio. Available with Chevrolet 4-speed transmission and 250 engine; Turbo Hydra-matic transmission and 250 or 400 engine; 3-speed transmission except when 400 engine is ordered; New Process 4-speed close-ratio or Powerglide transmission only	JA1	.95	12.00	12.95
→ Maximum Traction. Not available when 400 engine is ordered	G87	9.50	125.00	134.50

OTHER OPTIONS

Air Cleaner, Oil-bath. Capacity 1 quart. Available on CS-KS20 models or CE20 models with 350 engine only	K48	.80	10.00	10.80
Air Conditioning, All-Weather: V8 models only. Includes HD radiator and 42-amp generator	C60	30.40	400.00	430.40
Batteries: 12-volt				
→ Auxiliary, 53-amp-hr, 9-plate	TP2	3.45	45.00	48.45
Heavy-Duty, 80-amp-hr, 15-plate	T50	1.25	16.00	17.25
Belts, Seat: Installed for third passenger. Not available when bucket seats are ordered.	AM3	.50	6.50	7.00

⊕ State and local taxes not included.

→ Indicates Change

C-K20 SERIES—GASOLINE

OPTIONS AND ACCESSORIES WHEN INSTALLED BY CHEVROLET

Description	Option Number	Factory D & H	List Price	Mfr's Suggested Retail Delivered Price [⊖]
Box, Tool Storage: C20 Fleetside Pickup models only. Includes 7" high, 28" wide and 17" deep reinforced plastic box with bottom hinge and separate key located on RH side forward of rear wheelhousing.	VK2	\$3.45	\$45.00	\$48.45
Bumpers:				
<i>Painted</i>				
Rear. Pickup models with standard painted front bumper only.	V38	1.70	22.00	23.70
Rear Step. Pickup models only	V43	3.65	48.00	51.65
→ <i>Chromed</i>				
Front and Rear. Pickup models only. Not available when Cheyenne or Cheyenne Super is ordered	V37	3.80	50.00	53.80
Front. Not available when painted rear bumper is ordered. Included when Cheyenne or Cheyenne Super is ordered	V46	1.15	15.00	16.15
Rear. Pickup models with Cheyenne or Cheyenne Super only	VF1	2.70	35.00	37.70
→ Caps, Hub: <i>Chromed.</i> Not available when 10.00-16.5/C tires are ordered. Included when Cheyenne Super is ordered				
C20 models only	P03	.80	10.00	10.80
K20 models only	P03	<i>Will Advise</i>		
Carrier, Spare Wheel:				
Fleetside Pickup models only (Side-mounted)	P13	1.10	14.00	15.10
Stepside Pickup models only (Side-mounted)	P13	1.25	16.00	17.25
Without chromed hub caps	P13	1.40	18.25	19.65
With chromed hub caps	P13			
Clutch, Heavy-Duty: Diameter 11". CS-KS20 models only. Included when Chevrolet 4-speed transmission or 292 engine is ordered				
	M01	.50	6.50	7.00
Cooling: HD radiator only. Included when air conditioning or automatic transmission is ordered.				
	V01	1.90	25.00	26.90
→ Floor, Pickup Box: Wood with steel skid strips. CS-CE-KS-KE20934 models only. Standard on CS-CE21034 models				
	E81	1.45	19.00	20.45
→ Gauges:				
Ammeter, temperature and oil pressure. Included when Cheyenne Super is ordered	Z53	.95	12.00	12.95
<i>Tachometer</i>				
Without Cheyenne Super. Also includes ammeter, temperature, and oil pressure gauges	U16	4.20	55.00	59.20
With Cheyenne Super	U16	<i>Will Advise</i>		
Generators:				
42-amp Delcotron. Included when air conditioning is ordered	K79	1.70	22.00	23.70
61-amp Delcotron	K76	2.30	30.00	32.30
Glass, Soft-Ray: All windows				
	A11	1.40	18.00	19.40
Guards, Door Edge				
	B93	.50	6.00	6.50
Harness, Camper Body Wiring: For camper body installation on Pickup models only				
	UY1	1.15	15.00	16.15
Hooks, Towing: Two front. Not available when chromed bumper is ordered				
	V76	1.40	18.00	19.40
Hubs, Front Free-Wheeling: K20 models only. Manual control at hubs				
	F76	5.55	73.00	78.55
Lamps:				
→ Cargo Area. Included when Cheyenne or Cheyenne Super is ordered	UF2	1.45	19.00	20.45
Roof Marker. Five	U01	1.90	25.00	26.90
→ Lighter, Cigar: Included when custom deluxe, Cheyenne or Cheyenne Super is ordered				
	U37	.40	5.00	5.40

⊖ State and local taxes not included.

→ Indicates Change

C-K20 SERIES—GASOLINE

OPTIONS AND ACCESSORIES WHEN INSTALLED BY CHEVROLET

Description	Option Number	Factory D & H	List Price	Mfr's Suggested Retail Delivered Price [⊕]
Mirrors, Exterior: Replaces standard LH and RH mirrors				
<i>Below-Eye-Line Type</i>				
7.5' x 10.5' painted	D29	\$ 1.50	\$ 19.50	\$ 21.00
7.5' x 10.5' stainless steel	DG4	2.70	35.00	37.70
<i>Camper Type</i>				
Painted	DF1	1.50	19.50	21.00
Stainless steel	DF2	3.75	49.00	52.75
→ Moldings, Custom: Fleetside Pickup models only				
<i>Lower fender, door, cab panel and pickup box moldings plus bright fuel filler cap. Included when Cheyenne, Cheyenne Super or deluxe two-tone paint is ordered</i>				
Without upper molding (Option B85)	BX2	3.45	45.00	48.45
With upper molding (Option B85)	BX2	3.05	40.00	43.05
<i>Upper fender, door, cab panel and pickup box moldings, bright taillight trim and fuel filler cap. Not available when optional paint stripe is ordered. Included when Cheyenne Super is ordered</i>				
Without Cheyenne	B85	3.45	45.00	48.45
With Cheyenne	B85	3.05	40.00	43.05
Nameplate, Custom Camper: Minimum tire requirements are 7.50-16/D tube-type or 8.75-16.5/D tubeless tires.				
<i>C20 models only</i>				
<i>With standard suspension. Available only when front stabilizer, HD rear shock absorbers and HD rear springs or auxiliary rear springs are ordered</i>				
	Z81	N.C.	N.C.	N.C.
<i>With optional rear leaf-type suspension. Available only when front stabilizer, HD front shock absorbers and HD rear springs are ordered</i>				
	Z81	N.C.	N.C.	N.C.
<i>K20 models only. Available only when HD rear springs and HD rear shock absorbers are ordered</i>				
	Z81	N.C.	N.C.	N.C.
Paints, Exterior: See Color and Trim Chart				
<i>Solid</i>				
		N.C.	N.C.	N.C.
<i>Conventional Two-Tone. With white secondary color.</i>				
		1.90	25.00	26.90
<i>Custom Two-Tone</i>				
		1.90	25.00	26.90
→ <i>Deluxe Two-Tone. Cab roof and area between upper and lower side moldings painted white. Fleetside Pickup models only</i>				
<i>Without Cheyenne or Cheyenne Super. Available only when custom upper moldings are ordered. Includes custom lower moldings</i>				
		8.75	115.00	123.75
<i>With Cheyenne. Available only when custom upper moldings are ordered</i>				
		5.70	75.00	80.70
<i>With Cheyenne Super</i>				
		5.70	75.00	80.70
Radios: Pushbutton control. Includes manual front antenna				
AM	U63	4.95	65.00	69.95
AM/FM	U69	10.75	141.00	151.75
→ Seats:				
<i>Bucket. Driver and passenger. Includes carpeting and console</i>				
<i>Without Cheyenne or Cheyenne Super</i>				
	A50	10.50	138.00	148.50
<i>With Cheyenne</i>				
	A50	8.60	113.00	121.60
<i>With Cheyenne Super</i>				
	A50	<i>Will Advise</i>		
<i>Full-Depth Foam. Not available when custom deluxe, Cheyenne or Cheyenne Super is ordered</i>				
	Z52	2.15	28.00	30.15

⊕ State and local taxes not included.

→ Indicates Change

C-K20 SERIES-GASOLINE

OPTIONS AND ACCESSORIES WHEN INSTALLED BY CHEVROLET

X

Description	Option Number	Factory D & H	List Price	Mfr's Suggested Retail Delivered Price [⊕]
Shock Absorbers:				
<i>Front and Rear, Heavy-Duty.</i> Not available when leaf-type rear suspension is ordered.	F51	\$ 1.15	\$ 15.00	\$ 16.15
<i>Front, Heavy-Duty.</i> Available only when leaf-type rear suspension is ordered. Not available on CS-CE21034 models	F52	.60	7.50	8.10
<i>Rear, Heavy-Duty.</i> Included when leaf-type rear suspension is ordered	G68	.65	8.00	8.65
<i>Superlift Rear.</i> C20 models only. Not available on CS-CE21034 models or when leaf-type rear suspension is ordered.	G66	3.45	45.00	48.45
Springs:				
<i>Front</i>				
→ Capacity 1750-lb each. C20 models only. Not available when 400 engine is ordered.	F60	.50	6.00	6.50
Capacity 1750-lb each. K20 models only.	F60	2.40	31.00	33.40
<i>Rear</i>				
C20 models only				
<i>Coil.</i> Capacity 3000-lb each. Not available on CS-CE21034 models or when leaf-type rear suspension is ordered.	G50	1.40	18.00	19.40
<i>Leaf-type.</i> Capacity 2750-lb each two stage. Available only on CS-CE21034 models or when leaf-type rear suspension is ordered.	G50	1.40	18.00	19.40
K20 models only. Capacity 2500-lb each	G50	1.40	18.00	19.40
<i>Auxiliary Rear.</i> C20 models only				
Capacity 500-lb each. Not available on CS-CE21034 models or when leaf-type rear suspension is ordered	G60	2.25	29.00	31.25
Capacity 4150-lb each, main and auxiliary. CS-CE21034 models only. Includes HD rear springs.	G60	3.05	40.00	43.05
Stabilizer, Front: C20 models only	F59	1.40	18.00	19.40
Stake Body: 8 ft. CS-CE20 Chassis-Cab models only. Includes (3) rear identification lamps and (2) rear side marker lamps.	E56	21.75	286.00	307.75
Steering, Power:				
C20 models only	N40	9.50	125.00	134.50
K20 models only	N40	10.65	140.00	150.65
Steering Wheel, Comfortilt: Available only when optional transmission is ordered	N33	4.20	55.00	59.20
Stripes, Body Side Paint:	D89	1.00	13.00	14.00
Support, Heavy-Duty Cross Sill: Chassis-Cab models only. Not available when stake body is ordered.	F19	1.40	18.00	19.40
Suspension, Rear Leaf: C20 models only. Not available on CS-CE21034 models or when NoSPIN rear axle is ordered. Includes capacity 2000-lb each two-stage rear leaf springs, 12" x 2½" rear brakes and HD rear shock absorbers. Also includes 4.56 Dana rear axle when Turbo Hydra-matic or Chevrolet 4-speed transmission with 250 engine, standard 3-speed, New Process 4-speed close-ratio or Powerglide transmission is ordered.	G70	1.15	15.00	16.15
→ Switches, Dome Lamp: Door operated. Included when custom deluxe, Cheyenne or Cheyenne Super is ordered	C80	.35	4.00	4.35
Throttle Control: Manual	K31	1.10	14.00	15.10
Tires and Wheels: See following pages				
Window, Sliding Rear	A28	3.80	50.00	53.80

⊕ State and local taxes not included.

→ Indicates Change

f.

C-K20 SERIES

TUBE-TYPE TIRES (Factory Installed)

Tire Size and Type		Rim Width Included In Tire Option	Option Number	Factory D & H	List Price	Mfr's Suggested Retail Delivered Price [⊕]
→ Note: Front and rear tires must be of the same rim width and diameter except when 10.00-16.5/C rear tires are specified. K20 models require use of same tread type on front and rear wheels.						
7.50-16/C (6PR) Maximum Tire Capacity (Each)—Front (2060) Rear (2060)						
—Highway	(4) Front & rear	6.00	R67	\$ 3.15	\$ 46.50	\$ 49.65
Nylon	(2) Front	6.00	R67	1.30	19.50	20.80
	(1) Spare	6.00	R67	6.20	58.00	64.20
—On-Off Road	(2) Front; K20 only	6.00	RM7	3.15	42.50	45.65
Nylon	(2) Rear	6.00	RM7	3.70	50.00	53.70
	(1) Spare	6.00	RM7	7.10	69.00	76.10
7.50-16/D (8PR) Maximum Tire Capacity (Each)—Front (2440) Rear (2440)						
—Highway	(4) Front & rear; K20 only	6.00	R68	4.95	65.50	70.45
Nylon	(2) Front; C20 only	6.00	R68	2.20	29.00	31.20
	(2) Rear	6.00	R68	2.75	36.50	39.25
	(1) Spare	6.00	R68	6.55	61.00	67.55
—On-Off Road	(4) Front & rear; K20 only	6.00	RMB	8.95	115.50	124.45
Nylon	(2) Rear	6.00	RMB	4.75	61.50	66.25
	(1) Spare	6.00	RMB	7.50	73.00	80.50
7.50-16/E (10PR) Maximum Tire Capacity (Each)—Front (2780) Rear (2780)						
—Highway	(4) Front & rear	6.00	RM5	9.15	109.50	118.65
Nylon	(2) Front; C20 only	6.00	RM5	4.30	51.00	55.30
	(1) Spare	6.00	RM5	7.75	74.00	81.75
—On-Off Road	(4) Front & rear; K20 only	6.00	RM6	13.85	169.50	183.35
Nylon	(2) Rear; C20 only	6.00	RM6	7.20	88.50	95.70
	(1) Spare	6.00	RM6	8.85	88.50	97.35

TUBELESS FLOTATION-TYPE TIRES (Factory Installed)

Not available on Stepside Pickup models						
10.00-16.5/C (6PR) Maximum Tire Capacity (Each)—Front (2330) Rear (2330)						
—Highway	(4) Front & rear; K20 only	8.25	R79	14.90	214.50	229.40
Nylon	(2) Front; C20 only	8.25	R79	6.60	96.00	102.60
	◆ (2) Rear; C20 only	8.25	R79	5.80	85.50	91.30
	● (1) Spare; C20 only	●	R79	8.45	91.00	99.45
	(1) Spare; K20 only	8.25	R79	8.45	91.00	99.45
—On-Off Road	(4) Front & rear; K20 only	8.25	RR2	17.35	256.50	273.85
Nylon	◆ (2) Rear; C20 only	8.25	RR2	7.00	106.50	113.50
	● (1) Spare; C20 only	●	RR2	9.05	101.00	110.05
	(1) Spare; K20 only	8.25	RR2	9.05	101.00	110.05

◆ Available only when 8.75 or 10.00-16.5 tubeless or 7.50-16 tube-type highway front tires are ordered. Optional spare wheel mandatory and must match either front or rear wheels. Production spare wheel deleted.

● Option S89 spare wheel mandatory.

◆ State and local taxes not included.

→ Indicates Change

NOTES

C20 & K20 SERIES SUBURBAN CARRYALLS

GVW Ratings up to 7500 lb

C20 SERIES—SUBURBAN CARRYALLS*

Six-Cylinder Models

CS20906 Suburban Carryall
CS20916 Suburban Carryall

V8 Models

CE20906 Suburban Carryall
CE20916 Suburban Carryall

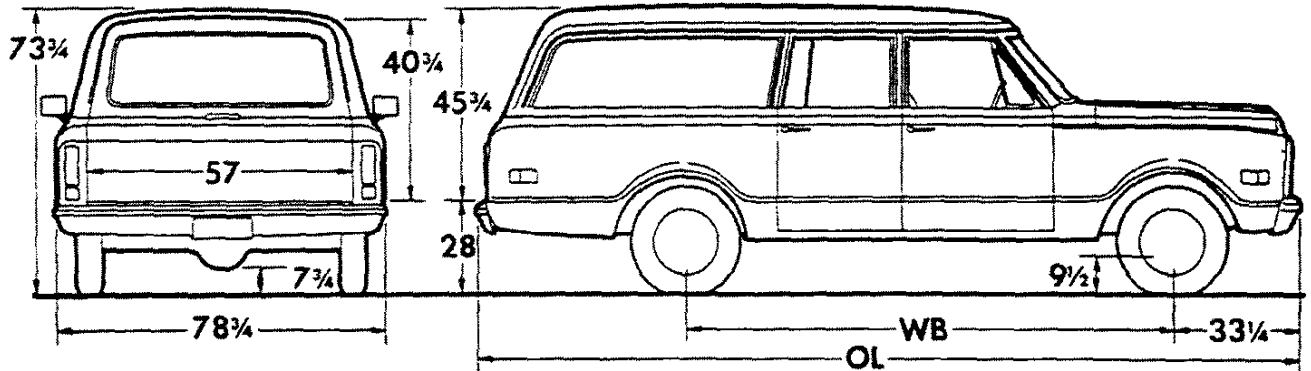

Models	Dimensions (in)★		→ Curb Weights (lb)		
	WB	OL	Front	Rear	Total
CS20906 CE20906	127	215½	2073 2174	2243 2258	4316 4432
CS20916 CE20916	127	215½	2077 2178	2247 2262	4324 4440

★Dimensions with std equipment, unloaded.

●Illustration shows 16 model rear end/lift gate.

K20 SERIES—SUBURBAN CARRYALLS*

Six-Cylinder Models

KS20906 Suburban Carryall
KS20916 Suburban Carryall

V8 Models

KE20906 Suburban Carryall
KE20916 Suburban Carryall

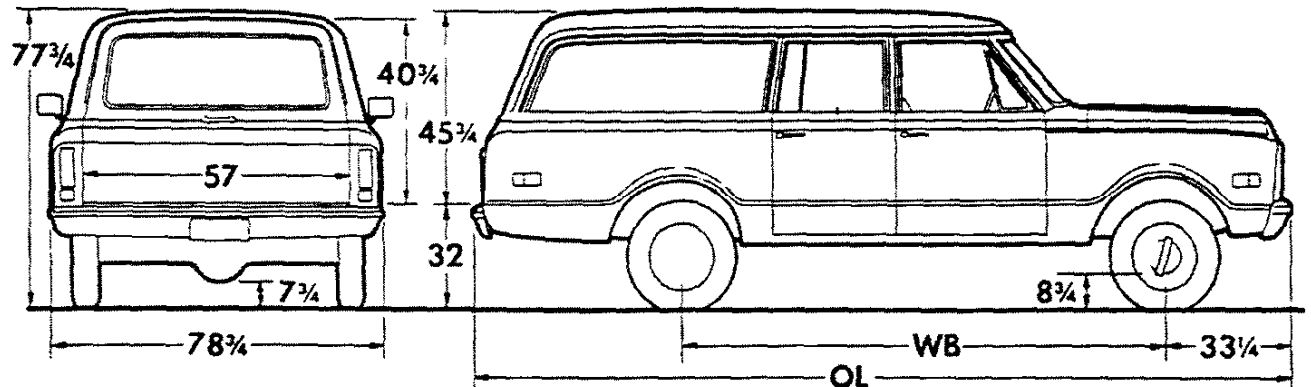

Models	Dimensions (in)★		→ Curb Weights (lb)		
	WB	OL	Front	Rear	Total
KS20906 KE20906	127	215½	2275 2382	2355 2368	4630 4750
KS20916 KE20916	127	215½	2279 2387	2359 2371	4638 4758

★ Dimensions with std equipment, unloaded.

● Illustration shows 16 model rear end/lift gate.

C20 SERIES SUBURBAN CARRYALLS

STANDARD EQUIPMENT

Air Cleaner: Oiled-paper element

Axle, Front: Independent; capacity 3000 lb

Axle, Rear: Hypoid full-floating type; ratio 4.57; capacity 5200 lb

→ **Battery:** 12-volt; side terminal connectors
 CS20: 54-plate; capacity 45 amp-hr
 CE20: 66-plate; capacity 61 amp-hr

Bodies: See *Model Options and Cabs, Bodies & Colors* section

Brakes, Service: Hydraulic; vacuum power; self-adjusting; dual system
 Front: Single-piston caliper disc type, 12.5" rotor
 Rear: Drum and shoe type; size—11" x 2 3/4"
 Rear brake area: drum 190.1 sq in; lining 113.9 sq in

Brake, Parking: Cable to rear wheels; area 113.9 sq in; foot operated

Bumpers: Front & rear, painted

Carburetor: CS20: single-barrel downdraft
 CE20: two-barrel downdraft

Clutch: CS20: diameter 10"; area 100 sq in
 CE20: diameter 11"; area 124 sq in

Cooling: CS20: 1 1/4" radiator core, cross-flow type; 446-sq-in area; 15-lb pressure cap
 CE20: 1 1/4" radiator core, cross-flow type; 480-sq-in area; 15-lb pressure cap

Controls & Instruments: Light switch; windshield wiper-washer switch; headlight beam control; speedometer; odometer; fuel gauge. Lights for generator, oil pressure, engine temperature, brake warning, direction signals and high beam indicator. Ignition switch with accessory position. Direction signal switch with freeway lane-change position. Hazard warning switch

Doors, Rear:
 06 models: Two; side-hinged
 16 models: Tail/lift gate

Doors, Side: Three; two right & one left

Emission Control Equipment: See Engine & Clutch section for types used

Engine:
 CS20: 250 Six
 Gross horsepower 145 @ 4200 rpm
 Net horsepower 110 @ 4000 rpm
 Gross torque, lb-ft. 230 @ 1600 rpm
 Net torque, lb-ft. 185 @ 1600 rpm
 CE20: 307 V8
 Gross horsepower 215 @ 4800 rpm
 Net horsepower 135 @ 4000 rpm
 Gross torque, lb-ft. 305 @ 2800 rpm
 Net torque, lb-ft. 230 @ 2000 rpm

Exhaust System: Single; fully aluminized; unizized muffler-tailpipe

Filter, Fuel: Plastic mesh in fuel tank; paper type in carburetor

Filter, Oil: Full-flow; 1-quart; throwaway type

Frame: 39,000-lb-test steel; section modulus 3.71

Fuel Pump: Mechanically actuated diaphragm

Generator: 37-amp Delcotron

GVW Plate: See GVW Selector

Heater & Defroster: Deluxe-Air

Lights & Reflectors: Two 7" Power Beam headlights; two Class A front combination parking/direction signals; two Class A rear combination tail/stop/direction signals; two front & two rear side marker combination lights & reflectors; two backup; one license; instrument panel & dome. Front side marker lights flash with turn signals

Mirror, Rearview: Exterior chrome RH & LH 4 1/2" x 6" head with fixed arm and inside 10" vinyl edged prismatic

Seat: Full-width bench; front only; vinyl trim

Seat Belts: Driver & passenger; includes retractors

Shock Absorbers: Front & rear; piston diameter 1"

Springs, Front: Coil; capacity 1500 lb each

Springs, Rear: Two-stage, coil; capacity 2000 lb each

Steering: Ball-gear, ratio 24:1; wheel, oval 17 1/2" x 17", 2-spoke

Tank, Fuel: Inside frame at rear; capacity approximately 22 gal

Tires: Four tubeless 8.75-16.5C(6PR) nylon front and single rear

Tools: 4000-lb mechanical jack; wheel wrench

Transmission: 3-speed fully synchronized; steering column gearshift; ratios 2.85, 1.68, 1.00, 2.95 (rev)

Wheels: Five 16.5" x 6.0"; attachment, 8 studs on 6 1/2" circle; spare carrier inside RH cargo area; 4 painted hubcaps

Windshield Wipers & Washer: Electric; 2-speed wipers

GVW SELECTOR

GVW Rating (lb)	Minimum Equipment Required for GVW Rating		
	Tires, Front	Tires, Rear	Chassis Equipment
6200	8.75-16.5C (6PR)	8.75-16.5C (6PR)	Standard
6700	8.75-16.5C (6PR)	8.75-16.5D (8PR)	3000-lb ea rear spring
7500	9.50-16.5D (8PR)	9.50-16.5D (8PR)	

K20 SERIES SUBURBAN CARRYALLS

STANDARD EQUIPMENT

Air Cleaner: Oiled-paper element

Axle, Front: Hypoid; ratio 4.55; capacity 3500 lb; yoke and trunion universal joints

Axle, Rear: Hypoid full-floating type; ratio 4.57; capacity 5200 lb

→ **Battery:** 12-volt; side terminal connectors
KS20: 54-plate; capacity 45 amp-hr
KE20: 66-plate; capacity 61 amp-hr

Bodies: See *Model Options and Cabs, Bodies & Colors section*

Brakes, Service: Hydraulic; vacuum power; self-adjusting; dual system

Front: Single-piston caliper disc type, 12.5" rotor

Rear: Drum and shoe type; size 12" x 2"

Rear brake area: drum 150.8 sq in; lining 89.0 sq in

Brake, Parking: Cable to rear wheels; area 89.0 sq in; foot operated

Bumpers: Front & rear, painted

Carburetor: KS20: single-barrel downdraft
KE20: two-barrel downdraft

Clutch: KS20: diameter 10"; area 100 sq in
KE20: diameter 11"; area 124 sq in

Cooling: KS20: 1¼" radiator core, cross-flow type; 446-sq-in area; 15-lb pressure cap
KE20: 1¼" radiator core, cross-flow type; 480-sq-in area; 15-lb pressure cap

Controls & Instruments: Light switch; windshield wiper-washer switch; headlight beam control; speedometer; odometer; fuel gauge. Lights for generator, oil pressure, engine temperature, brake warning, direction signals and high beam indicator. Ignition switch with accessory position. Direction signal switch with freeway lane-change position. Hazard warning switch

Doors, Rear:

06 models: Two; side-hinged

16 models: Tail/lift gate

Doors, Side: Three; two right & one left

Emission Control Equipment: See *Engine & Clutch section* for types used

Engine: KS20: 250 Six

Gross horsepower.....145 @ 4200 rpm

Net horsepower.....110 @ 4000 rpm

Gross torque, lb-ft.....230 @ 1600 rpm

Net torque, lb-ft.....185 @ 1600 rpm

KE20: 307 V8

Gross horsepower.....215 @ 4800 rpm

Net horsepower.....135 @ 4000 rpm

Gross torque, lb-ft.....305 @ 2800 rpm

Net torque, lb-ft.....230 @ 2000 rpm

Exhaust System: Single; fully aluminized; unitized muffler-tailpipe

Filter, Fuel: Plastic mesh in fuel tank; paper type in carburetor

Filter, Oil: Full-flow; 1-quart; throwaway type

Frame: 39,000-lb-test steel; section modulus 3.48

Fuel Pump: Mechanically actuated diaphragm

Generator: 37-amp Delcotron

GVW Plate: See GVW Selector

Heater & Defroster: Deluxe-Air

Lights & Reflectors: Two 7" Power Beam headlights; two Class A front combination parking/direction signals; two Class A rear combination tail/stop/direction signals; two front and two rear side marker combination lights and reflectors; two backup; one license; instrument panel and dome. Front side marker lights flash with turn signals

Mirror, Rearview: Exterior chrome RH & LH 4½" x 6" head with fixed arm and inside 10" vinyl edged prismatic

Seat: Full-width bench; front only; vinyl trim

Seat Belts: Driver & passenger; includes retractors

Shock Absorbers: Front & rear; piston diameter 1"

Springs, Front: Tapered-leaf; capacity 1600 lb each

Springs, Rear: Two-stage; combination multi-leaf & tapered-leaf; capacity 1900 lb each

Steering: Ball-gear, ratio 24:1; wheel, oval 17½" x 17", 2-spoke

Tank, Fuel: Inside frame at rear; capacity approx 22 gal

Tires: Four tubeless 8.75—16.5C (6PR) nylon front, single rear

Tools: 4000-lb mechanical jack; wheel wrench

Transfer Case: New Process 205, 2-speed; ratios 1.96 & 1.00, power take-off opening at left side, single control lever

Transmission: 3-speed fully synchronized; steering column gearshift; ratios 3.03, 1.75, 1.00, 3.02 (rev)

Wheels: Five 16.5" x 6.0"; attachment, 8 studs on 6½" circle; spare carrier inside RH cargo area

Windshield Wipers & Washer: Electric; 2-speed wipers

GVW SELECTOR

GVW Rating (lb)	Minimum Equipment Required for GVW Rating		
	Tires, Front	Tires, Rear	Chassis Equipment
6400	8.75-16.5C (6PR)	8.75-16.5C (6PR)	Standard
7200	8.75-16.5C (6PR)	8.75-16.5D (8PR)	2500-lb ea rear spring
7500	9.50-16.5D (8PR)	9.50-16.5D (8PR)	

20 SERIES POWER TEAMS SUBURBAN CARRYALL

C20 SERIES

ENGINE	TRANSMISSION	AXLE RATIOS		
		Chevrolet Rear Axle		Dana Rear Axle Included
		Std	Opt	
250 Six	Chevrolet 3-Speed	4.57	4.10	—
	Chevrolet CH465 4-Speed	4.57	4.10	—
	Powerglide	4.57	4.10	—
	Turbo Hydro-matic	4.57	4.10	—
292 Six 307 V8	Chevrolet 3-Speed	4.57	4.10	—
	Chevrolet CH465 4-Speed	4.10	4.57	—
307 V8	Powerglide	4.57	4.10	—
292 Six 307 V8	Turbo Hydro-matic	4.10	4.57	—
350 V8	Chevrolet 3-Speed H.D.	4.57	4.10	—
	Chevrolet CH465 4-Speed	4.10	4.57	—
	New Process 435CR 4-Speed	4.57	4.10	—
	Turbo Hydro-matic	4.10	4.57	—
400 V8	Chevrolet 3-Speed H.D.	—	—	3.54
	Chevrolet CH465 4-Speed	—	—	3.54
	Turbo Hydro-matic	—	—	3.54

K20 SERIES

ENGINE	TRANSMISSION	TRANSFER CASE	AXLE RATIOS	
			STD	OPT
250 Six	Chevrolet 3-Speed H.D.	New Process 205	4.57	—
292 Six	Chevrolet CH465 4-Speed		4.57	—
	Turbo Hydro-matic		4.57	—
307 V8	Chevrolet 3-Speed H.D.		4.57	—
350 V8	Chevrolet CH465 4-Speed		4.57†	—
	Turbo Hydro-matic		4.57†	—

†4.10 ratio used with 350 V8.

OPTIONAL ENGINE RATINGS

CE, KE20 with 292 Six

Gross Horsepower165 @ 4000 rpm
 Net Horsepower125 @ 3600 rpm
 Gross Torque, lb-ft.270 @ 1600 rpm
 Net Torque, lb-ft.225 @ 2400 rpm

CE, KE20 with 350 V8

Gross Horsepower250 @ 4600 rpm
 Net Horsepower170 @ 3600 rpm
 Gross Torque, lb-ft.350 @ 3000 rpm
 Net Torque, lb-ft.310 @ 2400 rpm

CE20 with 400 V8

Gross Horsepower300 @ 4800 rpm
 Net Horsepower240 @ 4400 rpm
 Gross Torque, lb-ft.400 @ 3200 rpm
 Net Torque, lb-ft.340 @ 3200 rpm

C-K20 SERIES SUBURBAN CARRYALL

OPTIONS AND ACCESSORIES WHEN INSTALLED BY CHEVROLET

Description	Option Number	Factory D & H	List Price	Mfr's Suggested Retail Delivered Price [◇]
Paints, Exterior: See Color and Trim chart				
<i>Solid color</i>		N.C.	N.C.	N.C.
<i>Conventional Two-tone</i> . With white secondary color		\$ 2.15	\$ 40.00	\$ 42.15
<i>Special Two-tone</i> . With white upper and lower secondary colors. Available only when custom lower moldings are ordered		3.20	60.00	63.20
Radios: Pushbutton control. Includes manual front antenna				
AM	U63	3.50	65.00	68.50
AM/FM	U69	7.55	141.00	148.55
Seats, Front: See exterior and interior color chart.				
<i>Custom Deluxe Vinyl, Full-Width</i> . Includes front seat area carpeting. Available in parchment trim only				
When optional rear seats are not ordered	A52	3.65	68.00	71.65
When center seat is ordered. Also includes center seat area carpeting	A52	6.30	118.00	124.30
When center and rear seats are ordered. Also includes center seat area carpeting	A52	8.45	158.00	166.45
<i>Bucket, Driver and Passenger</i> . Includes front seat area carpeting and center console. Available in parchment trim only				
When optional rear seats are not ordered	A50	6.55	123.00	129.55
When center seat is ordered. Also includes center seat area carpeting	A50	9.25	173.00	182.25
When center and rear seats are ordered. Also includes center seat area carpeting	A50	11.35	213.00	224.35
Seats, Rear: Seat trim always matches the front seats whether standard or optional. The price of matching seat trim is included when custom deluxe or optional front seats are ordered. Includes RH coat hook.				
<i>Center Seat</i> . Includes HD front and rear springs on C20 models only, LH and RH armrests and seat belts				
	AS3	6.00	112.00	118.00
<i>Center and Rear Seat</i> . Includes HD front and rear springs on C20 models only, LH and RH armrests and seat belts				
	A80	11.50	216.00	227.50
Shock Absorbers:				
<i>Front and Rear</i> . Heavy-duty				
	F51	.80	15.00	15.80
<i>Rear</i> . Heavy-duty				
	G68	.45	8.00	8.45
<i>Superlift Rear</i> . C20 models only				
	G66	2.40	45.00	47.40
Springs, Heavy-Duty:				
<i>Front</i>				
Capacity 1750-lb each. C20 models only. Included when center or rear seat is ordered				
	F60	.35	6.00	6.35
Capacity 1750-lb each. K20 models only				
	F60	1.65	31.00	32.65
<i>Rear</i>				
Capacity 3000-lb each. C20 models with HD front springs only. Included when center or rear seat is ordered				
	G50	1.00	18.00	19.00
Capacity 2500-lb each. K20 models only				
	G50	1.00	18.00	19.00
<i>Auxiliary Rear</i> . Capacity 500-lb each. C20 models only				
	G60	1.55	29.00	30.55
Stabilizer, Front: C20 models only				
	F59	1.00	18.00	19.00
Steering, Power:				
C20 models only				
	N40	6.65	125.00	131.65
K20 models only				
	N40	7.45	140.00	147.45
Steering Wheel, Comfortilt: Available only when optional transmission is ordered				
	N33	2.95	55.00	57.95
Switches, Dome Lamp: Front doors. Included when custom deluxe is ordered				
	C80	.25	4.00	4.25
Throttle Control: Manual				
	K31	.75	14.00	14.75
Tires: See following page				

◇ State and local taxes not included.

C-K20 SERIES SUBURBAN CARRYALL

WIDE BASE TUBELESS TIRES (Factory Installed)

Tire Size and Type <small>Note: Front and rear tires must be of the same rim width. K20 models require use of same tread type on front and rear wheels.</small>	Rim Width Included In Tire Option	Option Number	Factory D & H	List Price	Mfr's Suggest Retail Delivered Price[⊕]
8.75-16.5/C (6PR) Maximum Tire Capacity (Each)—Front (1990) Rear (1990)					
—Highway	(4) Front & Rear	6.00	Std	N.C.	N.C.
Nylon	(1) Spare	6.00	RP5	\$ 6.00	\$66.00
—On-Off Road	(2) Front; K20 only	6.00	RP2	1.35	21.00
Nylon	(2) Rear	6.00	RP2	1.35	21.00
	(1) Spare	6.00	RP2	7.05	84.00
8.75-16.5/D (8PR) Maximum Tire Capacity (Each)—Front (2350) Rear (2350)					
—Highway	(2) Front	6.00	RP6	1.20	19.00
Nylon	(2) Rear	6.00	RP6	1.20	19.00
	(1) Spare	6.00	RP6	6.50	74.00
—On-Off Road	(4) Front & Rear; K20 only	6.00	RQ4	4.80	80.00
Nylon	(2) Rear	6.00	RQ4	2.40	40.00
	(1) Spare	6.00	RQ4	7.10	84.00
9.50-16.5/D (8PR) Maximum Tire Capacity (Each)—Front (2780) Rear (2780)					
—Highway	(4) Front & Rear	6.75	RP9	6.95	99.00
Nylon	(2) Front	6.75	RP9	3.40	48.00
	(1) Spare	6.75	RP9	7.50	87.00
—On-Off Road	(4) Front & Rear; K20 only	6.75	RQ5	8.95	141.00
Nylon	(2) Rear; C20 only	6.75	RQ5	4.55	72.00
	(1) Spare	6.75	RQ5	8.00	97.00

⊕ State and local taxes not included.

C20 SERIES—2-WHEEL DRIVE SUBURBAN CARRYALL K20 SERIES—4-WHEEL DRIVE SUBURBAN CARRYALL

1971 MODELS WITH STANDARD EQUIPMENT

Model Number and Description	Wheel-base	Factory D & H	List Price	Mfr's Suggested Retail Price*	Destination Charge & Group Number	Total
→ 6-Cylinder 145-hp High Torque 250 Engine						
CS20906 Suburban Carryall (Panel Doors)	127"	\$198.00	\$3551.00	\$3749.00	15	
KS20906 Suburban Carryall (Panel Doors)	127"	237.00	4269.00	4506.00	16	
CS20916 Suburban Carryall (End Gate)	127"	199.00	3581.00	3780.00	15	
KS20916 Suburban Carryall (End Gate)	127"	239.00	4299.00	4538.00	16	
→ 8-Cylinder 215-hp High Torque 307 Engine						
CE20906 Suburban Carryall (Panel Doors)	127"	204.00	3666.00	3870.00	15	
KE20906 Suburban Carryall (Panel Doors)	127"	243.00	4384.00	4627.00	16	
CE20916 Suburban Carryall (End Gate)	127"	205.00	3696.00	3901.00	15	
KE20916 Suburban Carryall (End Gate)	127"	245.00	4414.00	4659.00	16	

* Manufacturer's Suggested Retail Prices do not include state and local taxes, license fees, options or accessories.

OPTIONS AND ACCESSORIES WHEN INSTALLED BY CHEVROLET

Description	Option Number	Factory D & H	List Price	Mfr's Suggested Retail Delivered Price [⊙]
-------------	---------------	---------------	------------	---

MODEL OPTION

Custom Deluxe: See Exterior and Interior Color Chart for interior colors. Includes vent window and windshield moldings; bright control knob trim; fender nameplates; color-keyed floor mat; white hardboard headlining; sidewall trim panels; cigar lighter; dual horns; special insulation; front door dome lamp switches; bright glove box nameplate and dome lamp bezel. Also includes spare tire cover when spare tire is ordered.

With standard front seat. Also includes full-depth foam seat with cloth trim

When optional center or rear seats are not ordered

When optional center seat is ordered. Also includes matching fabric upholstery

When optional center and rear seats are ordered. Also includes matching fabric upholstery

When bucket seats or custom deluxe front seat is ordered

When optional center or rear seats are not ordered

When optional center seat is ordered

When optional center and rear seat is ordered. Also includes color-keyed rear floor mat

Z62	\$8.90	\$167.00	\$175.90
Z62	9.45	177.00	186.45
Z62	9.95	187.00	196.95
Z62	6.80	127.00	133.80
Z62	6.80	127.00	133.80
Z62	7.85	147.00	154.85

POWER TEAMS AND AXLES

Engines:

292 Six. CS-KS20 models with 3-speed, Chevrolet 4-speed or Turbo Hydra-matic transmission only. Includes 11" clutch. CS20 models also include 4.10 ratio rear axle when Chevrolet 4-speed or Turbo Hydra-matic transmission is ordered

350 V8. CE-KE20 models only. Includes 4-barrel carburetor and 12" coil clutch. Also includes 4.10 ratio rear axle when Chevrolet 4-speed or Turbo Hydra-matic transmission is ordered

400 V8. CE20 models with 3-speed, Chevrolet 4-speed or Turbo Hydra-matic transmission only. Includes 4-barrel carburetor, dual exhausts, 3.54 ratio rear axle and 12" coil clutch

Liquid Petroleum Gas Conversion. C20 models only. Not available when automatic transmission, HD clutch, 307 or 400 engine is ordered. Includes internal modifications of valves, compression ratio and heat shield only

L25	4.80	90.00	94.80
LS9	2.25	42.00	44.25
L47	8.80	165.00	173.80
L56	4.80	90.00	94.80

⊙ State and local taxes not included.

→ Indicates Change

C-K20 SERIES SUBURBAN CARRYALL

OPTIONS AND ACCESSORIES WHEN INSTALLED BY CHEVROLET

Description	Option Number	Factory D & H	List Price	Mfr's Suggested Retail Delivered Price [◇]
Transmissions:				
<i>Powerglide.</i> C20 models with standard engine only. Not available when 4.11 ratio rear axle is specified with 7.50-16 tires. Includes HD radiator	M35	\$10.65	\$200.00	\$210.65
<i>Turbo Hydra-matic.</i> Includes HD radiator				
Without 400 engine. Includes 4.10 ratio rear axle on C20 models when 292, 307 or 350 engine or K20 models with 350 engine is ordered	M49	12.25	230.00	242.25
With 400 engine. Includes 3.54 ratio rear axle.	M49	12.80	240.00	252.80
Chevrolet 4-Speed				
C20 models only. Includes 4.10 ratio rear axle when 292, 307 or 350 engine is ordered	M20	6.15	115.00	121.15
K20 models only. Includes 4.10 ratio rear axle when 350 engine is ordered	M20	5.60	105.00	110.60
<i>New Process 43SCR 4-Speed Close-Ratio.</i> CE20 models with 350 engine only.	M28	7.75	145.00	152.75
Axles, Rear:				
<i>4.10 Ratio.</i> C20 models with Chevrolet 4-speed or Turbo Hydra-matic transmission and 250 engine; 3-speed, New Process 4-speed close-ratio or Powerglide transmission only. Not available when 400 engine is ordered	HB8	.65	12.00	12.65
<i>4.57 Ratio.</i> C20 models only. Available only when Chevrolet 4-speed or Turbo Hydra-matic transmission with 292, 307 or 350 engine is ordered	H20	.65	12.00	12.65
<i>NoSPIN.</i> Not available when 400 engine is ordered	G86	6.65	125.00	131.65
<i>Maximum Traction.</i> Available only when 400 engine is ordered	G87	6.65	125.00	131.65

OTHER OPTIONS

Air Cleaner: Oil-bath. Capacity 1-quart. Available only on CS-KS20 models or CE20 models with 350 engine	K48	.55	10.00	10.55
Air Conditioning, Interior Roof-Mounted: V8 model only. Available only when custom deluxe is ordered. Includes HD radiator and 42-amp generator	C69	33.25	625.00	658.25
Batteries: 12-volt				
→ <i>Auxiliary.</i> 53-amp-hr, 9-plate	FP2	2.40	45.00	47.40
<i>Heavy-Duty.</i> 80-amp-hr, 15-plate	T60	.90	16.00	16.90
Belts, Seat: Installed for third passenger				
<i>Front Seat.</i> Not available when bucket seats are ordered	AM3	.35	6.50	6.85
<i>Center Seat</i>	A68	.35	6.50	6.85
<i>Center and Rear Seat</i>	A68	.70	13.00	13.70
Bumpers: Chromed, front and rear	V37	1.60	30.00	31.60
Caps, Hub: Chromed. C20 models only	P03	.55	10.00	10.55
Clutch, Heavy-Duty: Diameter 11". CS-KS20 models only. Included when Chevrolet 4-speed transmission or 292 engine is ordered	M01	.35	6.50	6.85
Cooling: HD radiator only. Included when air conditioning or automatic transmission is ordered	V01	1.35	25.00	26.35
Gauges:				
<i>Ammeter, temperature and oil pressure</i>	Z53	.65	12.00	12.65
<i>Tachometer, ammeter, temperature and oil pressure</i>	U16	2.95	55.00	57.95
Generators:				
<i>42-amp Delcotron.</i> Included when air conditioning is ordered	K79	1.20	22.00	23.20
<i>61-amp Delcotron</i>	K76	1.60	30.00	31.60
Glass, Soft-Ray: All windows	A11	1.55	29.00	30.55
Guards, Door Edge	B93	.45	8.00	8.45
Hooks, Towing: Two, front. Not available with chromed bumpers	V76	1.00	18.00	19.00
Hubs, Front Free-Wheeling: K20 models only. Manual control at hubs	F76	3.90	73.00	76.90
Lamps: Roof Marker. Five	U01	1.35	25.00	26.35
Lighter, Cigar: Included when custom deluxe is ordered	U37	.30	5.00	5.30
Mirrors, Exterior: Replacing standard LH and RH mirrors				
<i>Below-Eye-Line type</i>				
7.5' x 10.5' painted	D29	1.05	19.50	20.55
7.5' x 10.5' stainless steel	DG4	1.90	35.00	36.90
<i>Camper type</i>				
Painted	DF1	1.05	19.50	20.55
Stainless steel	DF2	2.65	49.00	51.65
Moldings, Custom: Includes bright fuel filler cap				
<i>Belt Line</i>	BX1	1.90	35.00	36.90
<i>Lower Fender, Door and Body</i>	BX2	2.15	40.00	42.15

◇ State and local taxes not included.

→ Indicates Change

C20 SERIES

GVW Ratings up to 7500 lb

C20 SERIES—STEPSIDE PICKUPS

Six-Cylinder Models

CS20904 Stepside Pickup

V8 Models

CE20904 Stepside Pickup

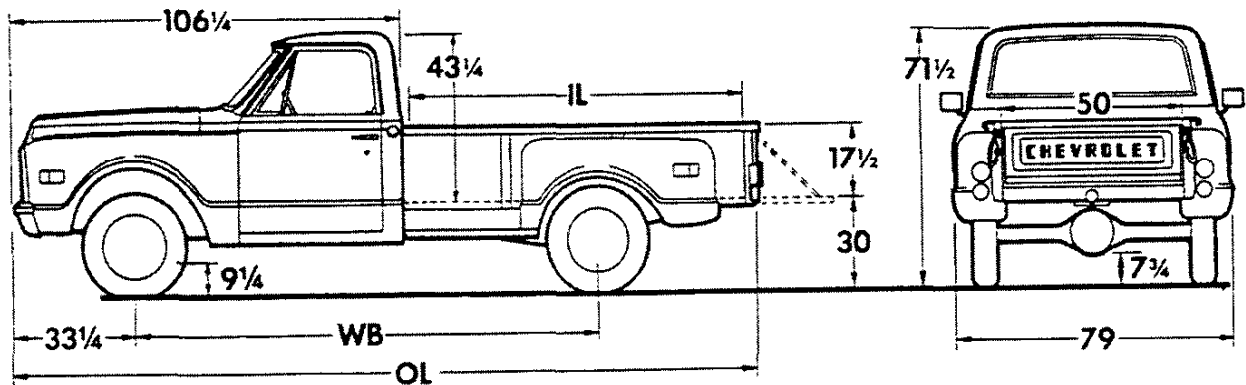

Models	Dimensions (in)★			→Curb Weights (lb)			Payload Wt. Dist.*	
	WB	IL	OL	Front	Rear	Total	Front	Rear
CS20904	127	98	207 3/4	2277	1674	3951	3%	97%
CE20904	127	98	207 3/4	2384	1683	4067	3%	97%

*Estimate based on water-level loading.

★Dimensions with std equipment, unloaded.

C20 SERIES—FLEETSIDE PICKUPS

Six-Cylinder Models

CS20934 Fleetside Pickup

V8 Models

CE20934 Fleetside Pickup

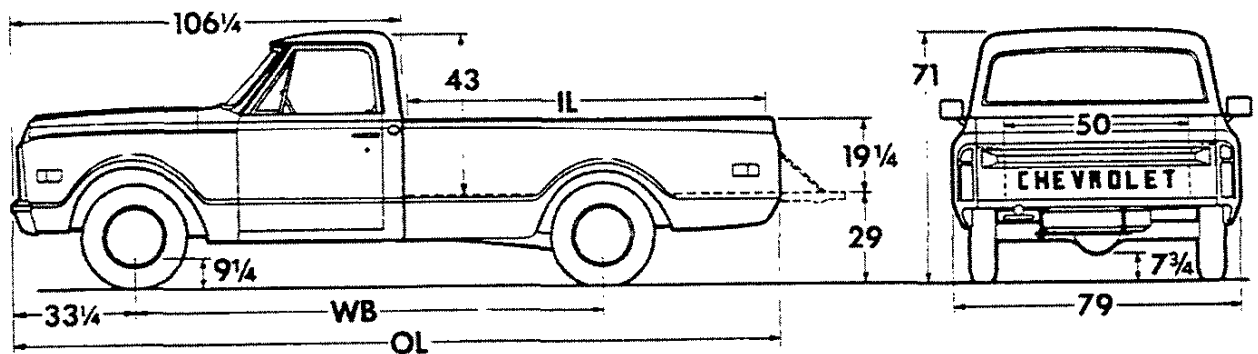

Models	Dimensions (in)★			→Curb Weights (lb)			Payload Wt. Dist.*	
	WB	IL	OL	Front	Rear	Total	Front	Rear
CS20934	127	98	207 3/4	2293	1753	4046	4%	96%
CE20934	127	98	207 3/4	2399	1763	4162	4%	96%

*Estimate based on water-level loading.

★Dimensions with std equipment, unloaded.

C20 SERIES

C20 SERIES—LONGHORN

Six-Cylinder Models

CS21034 Longhorn

V8 Models

CE21034 Longhorn

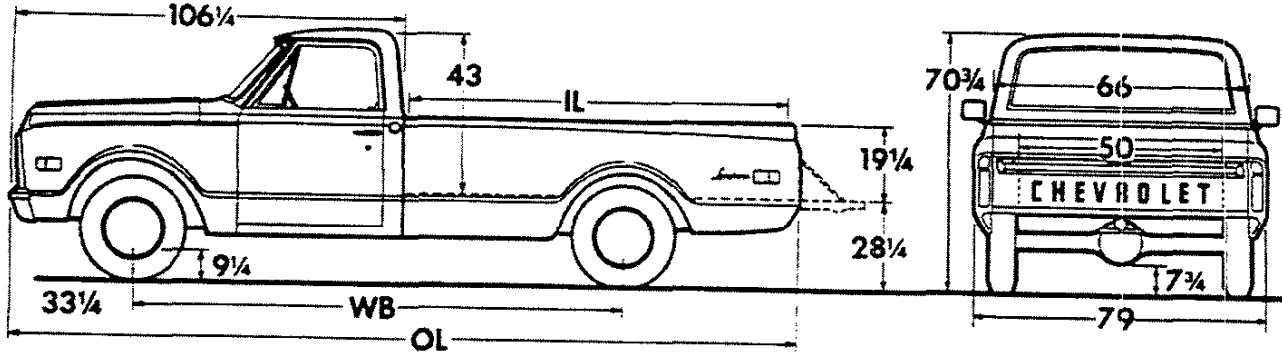

Models	Dimensions (in)★			→Curb Weights (lb)			Body-Payload Wt. Dist.	
	WB	IL	OL	Front	Rear	Total	Front	Rear
CS21034	133	104	213 3/4	2239	1852	4091	3%	97%
CE21034				2345	1865	4210		

★ Dimensions with std equipment, unloaded.

C20 SERIES—CHASSIS-CABS

Six-Cylinder Models

CS20903 Chassis-Cab

V8 Models

CE20903 Chassis-Cab

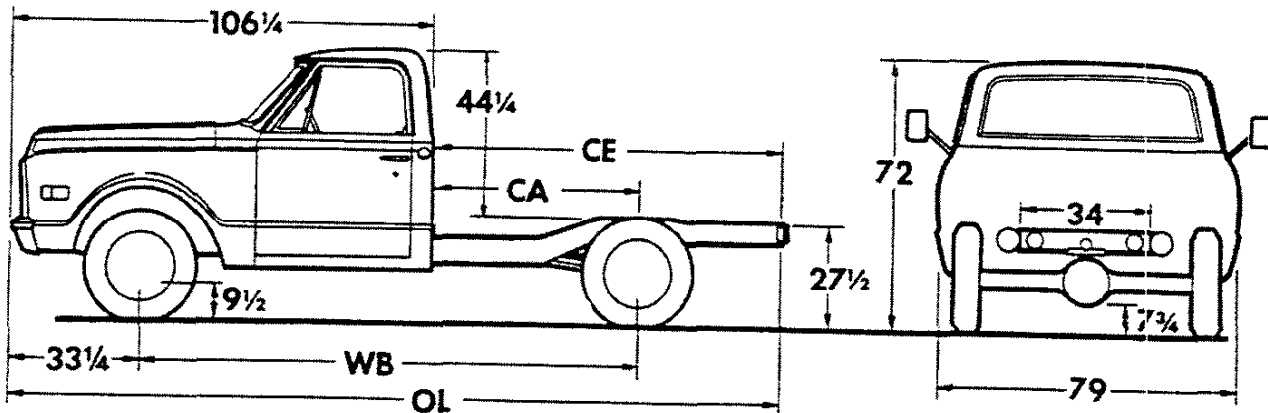

Models	Dimensions (in)★				→Curb Weights (lb)			Body-Payload Wt. Dist.*		
	WB	CA	CE	OL	Front	Rear	Total	Body	Front	Rear
CS20903	127	54	95 1/2	201 1/4	2284	1265	3549	7'	8%	92%
CE20903					2395	1270	3665	7 1/2'	6%	94%
								8'	3%	97%

*Estimate based on water-level loading.

★Dimensions with std equipment, unloaded.

K20 SERIES

GVW Ratings up to 7500 lb

K20 SERIES—STEPSIDE PICKUPS

Six-Cylinder Models

KS20904 Stepside Pickup

V8 Models

KE20904 Stepside Pickup

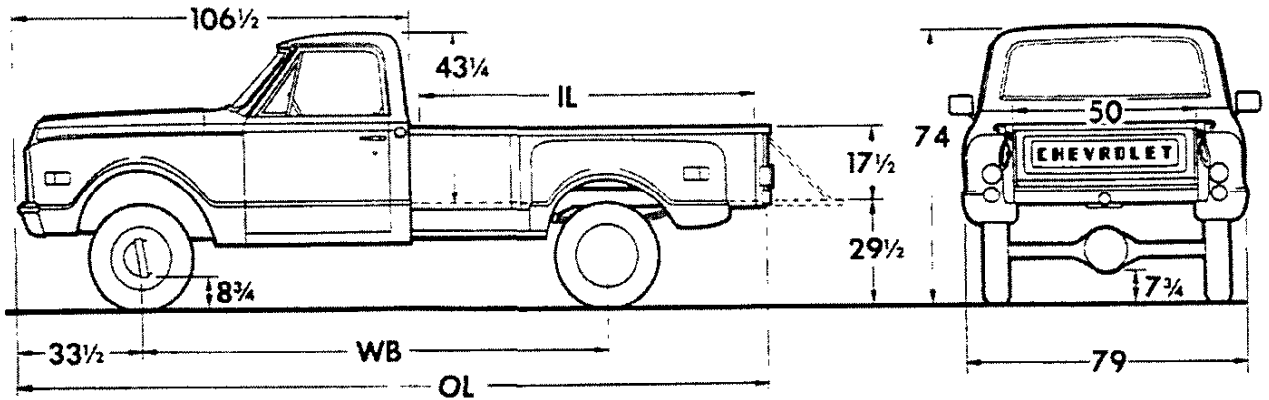

Models	Dimensions (in)★			→Curb Weights (lb)			Payload Wt. Dist.*	
	WB	IL	OL	Front	Rear	Total	Front	Rear
KS20904 KE20904	127	98	208	2501 2614	1764 1771	4265 4385	3%	97%

*Estimate based on water-level loading.

★Dimensions with std equipment, unloaded.

K20 SERIES—FLEETSIDE PICKUPS

Six-Cylinder Models

KS20934 Fleetside Pickup

V8 Models

KE20934 Fleetside Pickup

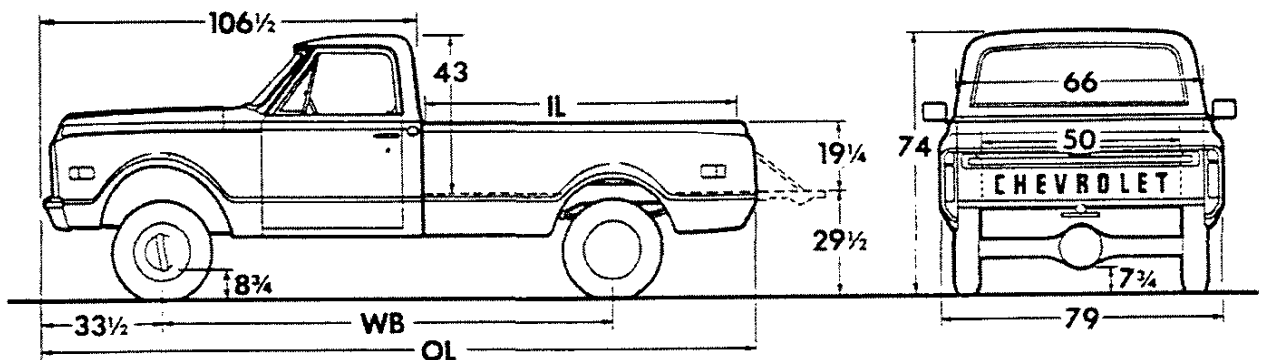

Models	Dimensions (in)★			→Curb Weights (lb)			Payload Wt. Dist.*	
	WB	IL	OL	Front	Rear	Total	Front	Rear
KS20934 KE20934	127	98	208	2514 2627	1846 1853	4360 4480	4%	96%

*Estimate based on water-level loading.

★Dimensions with std equipment, unloaded.

K20 SERIES

K20 SERIES—CHASSIS-CABS

Six-Cylinder Models

KS20903 Chassis-Cab

V8 Models

KE20903 Chassis-Cab

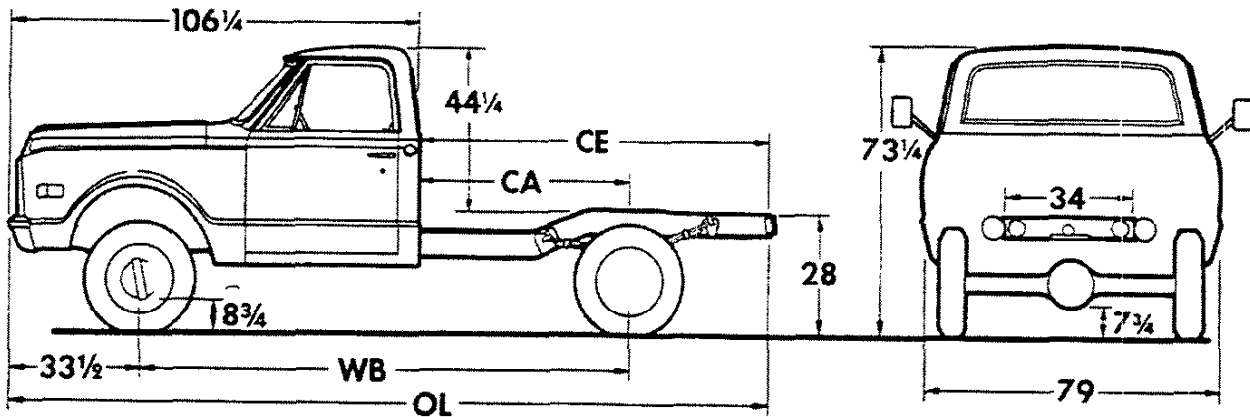

Models	Dimensions (in)★				→ Curb Weights (lb)			Body-Payload Wt. Dist.*		
	WB	CA	CE	OL	Front	Rear	Total	Body	Front†	Rear‡
KS20903	127	54	95 1/2	202	2524	1337	3861	7'	8%	92%
KE20903					2642	1339	3981	7 1/2'	6%	94%
								8'	3%	97%

*Estimate based on water-level loading.

★Dimensions with std equipment, unloaded.

C30 SERIES

C30 SERIES—CHASSIS-CAB

GVW Ratings up to 14,000 lb

Six-Cylinder Models

CS31003 Chassis-Cab
CS31403 Chassis-Cab

V8 Models

CE31003 Chassis-Cab
CE31403 Chassis-Cab

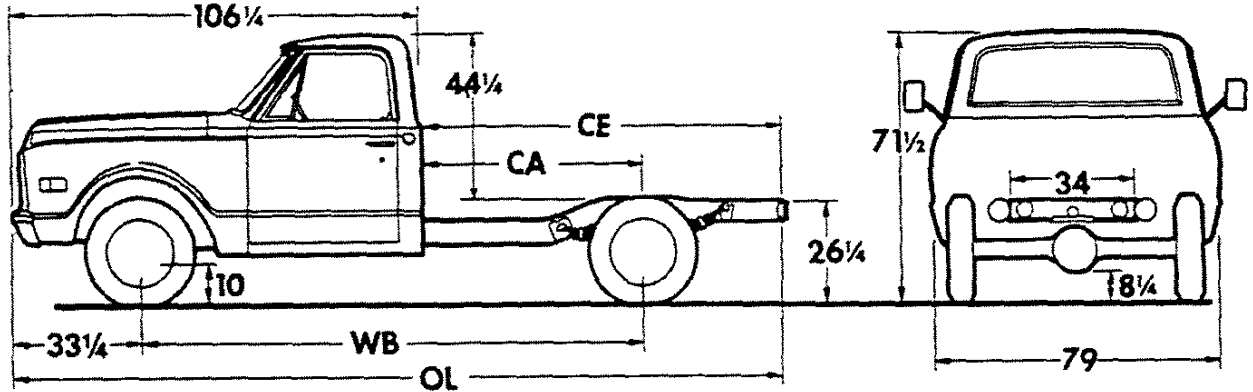

Models	Dimensions (in)*				→Curb Weights (lb)			Body-Payload Wt. Dist.* (% front—% rear)		
	WB	CA	CE	OL	Front	Rear	Total	Body	CS31003 CE31003	CS31403 CE31403
CS31003 CE31003	133	60	107	213 1/4	2307 2416	1385 1390	3692 3806	7 1/2' 8' 8 1/2' 9'	9-91 8-92 5-95 3-97	— — — —
CS31403 CE31403	157	84	131	237 1/4	2321 2428	1510 1517	3831 3945	10' 11' 12' 13'	— — — —	13-87 10-90 6-94 2-98

*Estimate based on water-level loading.

*Dimensions with std equipment, unloaded.

C30 SERIES—STEPSIDE PICKUPS

GVW Ratings up to 9000 lb

Six-Cylinder Models

CS31004 Stepside Pickup

V8 Models

CE31004 Stepside Pickup

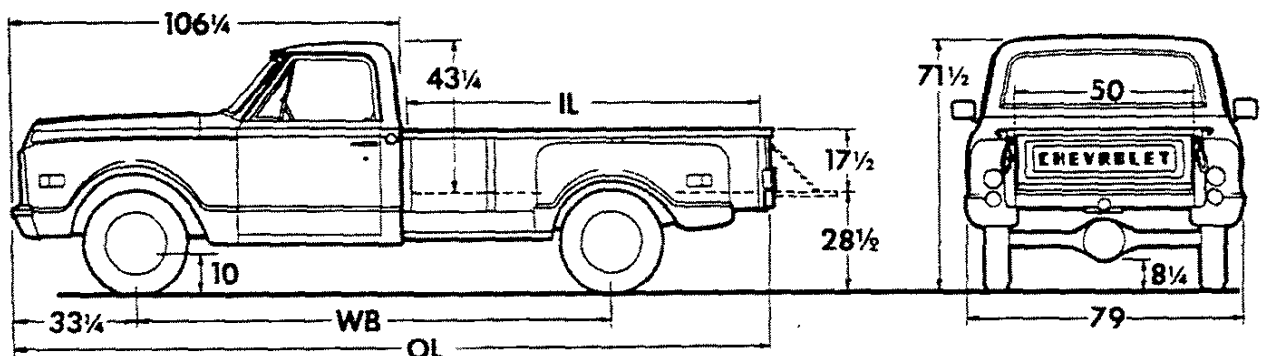

Models	Dimensions (in)*			→Curb Weights (lb)			Body-Payload Wt. Dist.*	
	WB	IL	OL	Front	Rear	Total	Front	Rear
CS31004 CE31004	133	108 1/4	217 3/4	2299 2404	1825 1834	4124 4238	3%	97%

*Estimate based on water-level loading.

*Dimensions with std equipment, unloaded.

C30 SERIES

C30 SERIES—LONGHORN

Six-Cylinder Models

CS31034 Longhorn

V8 Models

CE31034 Longhorn

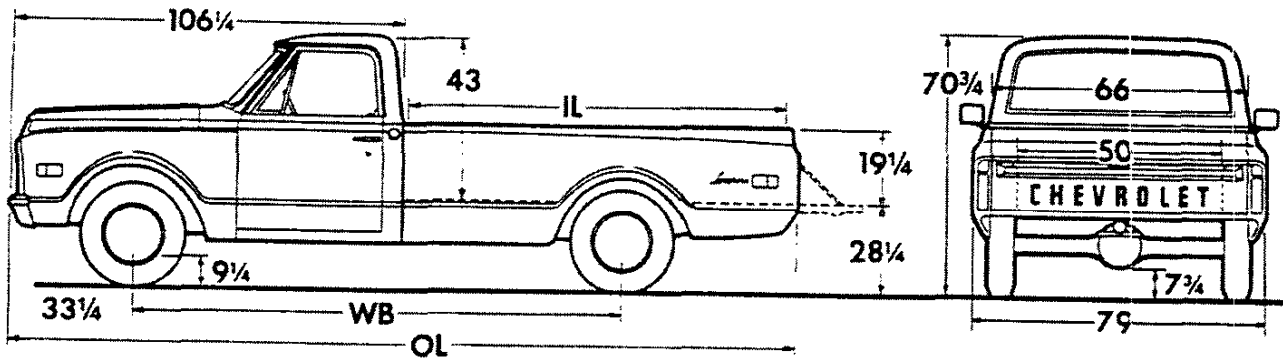

Models	Dimensions (in)★			→Curb Weights (lb)			Body-Payload Wt. Dist.*	
	WB	IL	OL	Front	Rear	Total	Front	Rear
CS31034	133	104	213 1/4	2305	1902	4207	3%	97%
CE31034				2410	1911	4321		

*Estimate based on water-level loading.

★Dimensions with std equipment, unloaded.

C30 SERIES—COWLS

Six-Cylinder Models

CS31002 Chassis-Cowl

V8 Models

CE31002 Chassis-Cowl

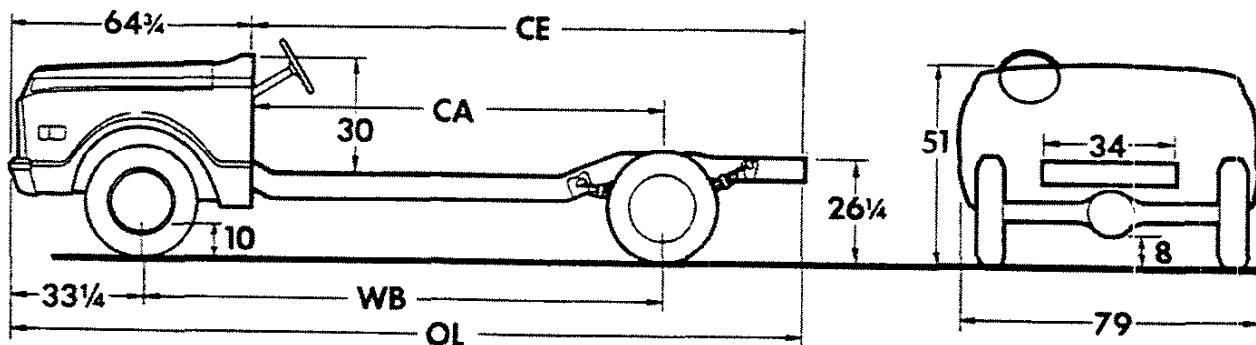

Models	Dimensions (in)★				→Curb Weights (lb)			Body-Payload Wt. Dist.	
	WB	CA	CE	OL	Front	Rear	Total	Front	Rear
CS31002	133	101 1/2	148 1/2	213 1/4	1959	1103	3062	Determined by style, length & weight of body	
CE31002					2064	1112	3176		

★Dimensions with std equipment, unloaded.

STANDARD EQUIPMENT

Air Cleaner: Oiled-paper element
Axle, Front: Independent; capacity 3500 lb
Axle, Rear: Hypoid full-floating type; ratio 4.57; capacity 7200 lb
Battery: 12-volt; side terminal connectors
 CS30: 54-plate; capacity 45 amp-hr
 CE30: 66-plate; capacity 61 amp-hr
Brakes, Service: Hydraulic/vacuum; cowl mounted; integral master cylinder and power unit with one 8.0" and one 9.5" diaphragm; self-adjusting; dual system
 Front: Single-piston caliper disc type, 12.5" rotor
 Rear: Drum and shoe type; size—13" x 2 1/2"
 Rear brake area: drum 204.2 sq in; lining 127.7 sq in
Brake, Parking: Cable to rear wheels; area 127.7 sq in; foot operated
Bumper: Front only; painted
Cab: See *Model Options and Cabs, Bodies & Colors section*
Carburetor: CS30: single-barrel downdraft
 CE30: two-barrel downdraft
Clutch: Diameter 11"; area 124 sq in
Cooling: CS30: 1 1/4" radiator core, cross-flow type; 446-sq-in area; 15-lb pressure cap
 CE30: 1 1/4" radiator core, cross-flow type; 480-sq-in area; 15-lb pressure cap
Controls & Instruments: 03, 04, 34 models—light switch; windshield wiper-washer switch; headlight beam control; speedometer; odometer; fuel gauge. Lights for generator, oil pressure, engine temperature, brake warning, direction signals and high beam indicator. Ignition switch with accessory position. Direction signal switch with freeway lane-change position. Hazard warning switch.
 02 models—light switch; headlight beam control; speedometer; odometer; high beam indicator light; fuel gauge; ammeter; oil pressure & engine temperature gauges; brake warning light. Ignition switch with accessory position. Direction signal switch with freeway lane-change position. Hazard warning switch
Emission Control Equipment: See Engine & Clutch section for types used
Engine: CS30: 250 Six
 Gross horsepower.....145 @ 4200 rpm
 Net horsepower.....110 @ 4000 rpm
 Gross torque, lb-ft.....230 @ 1600 rpm
 Net torque, lb-ft.....185 @ 1600 rpm
 CE30: 307 V8
 Gross horsepower.....215 @ 4800 rpm
 Net horsepower.....135 @ 4000 rpm
 Gross torque, lb-ft.....305 @ 2800 rpm
 Net torque, lb-ft.....230 @ 2000 rpm
Exhaust System: Single; fully aluminized unitized muffler-tailpipe
Filter, Fuel: Plastic mesh in fuel tank; paper type in carburetor

Filter, Oil: Full-flow; 1-quart; throwaway type
Frame: 39,000-lb-test steel, section modulus 5.05 (133" WB models); 7.29 (157" WB models)
Generator: 37-amp Delcotron
GVW Plate: See GVW Selector
Heater & Defroster: Deluxe-Air (except Cowl)
Lights & Reflectors:
 03 models: Two 7" Power Beam headlights; two Class A front combination parking/direction signals; two Class A rear combination tail/stop/direction signals; two front side marker combination lights and reflectors; two backup; one license; instrument panel and dome. Front side marker lights flash with turn signals
 04, 34 models: Same as 03 models plus two rear side marker combination lights & reflectors
 02 models: Two 7" Power Beam headlights; two Class A front combination parking/direction signals; two front side combination side marker lights/direction signals and reflectors; wiring only for backup, stop and rear direction signals; instrument panel
Mirror, Rearview: Inside 10" vinyl-edged prismatic (except 02 models)
 02 models: None
 03 models: Exterior painted RH & LH 5 1/2" x 7 1/2" head with folding arm
 04, 34 models: Exterior chrome RH & LH 4 1/2" x 6" head with fixed arm
Seats: Full-width (except Cowl models); vinyl trim
Seat Belts: Driver & passenger (except Cowl models); includes retractors
Shock Absorbers: Front; piston diameter 1"
Springs, Front: Coil; capacity 1650 lb each
Springs, Rear: Leaf, two-stage; capacity 2400 lb each
Steering: Ball-gear, ratio 24:1; wheel, oval 17 1/2" x 17", 2-spoke
Tank, Fuel:
 02—outside frame on left; capacity approx 21 gal
 03, 04, 34—back of seat in cab; capacity approx 21 gal
Tires: Tubeless; four 8.75-16.5C(6PR) nylon front and single rear
Tools: 4000-lb mechanical jack when single rear wheels are used; wheel wrench. Jack not included on Cowl models
Transmission: Chevrolet CH465 4-speed; ratios 6.55, 3.58, 1.70, 1.00, 6.09 (rev); SAE 6-bolt power take-off openings on both sides
Wheels: Five 16.5" x 6.0"; attachment, 8 studs on 6 1/2" circle; spare carrier under frame and 4 painted hubcaps when single rear wheels are used; spare wheel and carrier not included on Cowl models
Windshield Wipers & Washer: Electric; 2-speed wipers; not included on 02 models

GVW SELECTOR

GVW Rating (lb)	Minimum Equipment Required for GVW Rating		
	Tires, Front	Tires, Rear	Chassis Equipment
6600	8.75-16.5C(6PR)	8.75-16.5C(6PR)	Standard
	6.50-16C(6PR)	6.50-16C(6PR) Dual	
8000	9.50-16.5D(8PR)	9.50-16.5D(8PR)	3100-lb ea rear spring
	6.50-16C(6PR)	6.50-16C(6PR) Dual	
9000	9.50-16.5D(8PR)	9.50-16.5E(10PR)	4150-lb ea main & auxiliary rear spring
	7.00-16C(6PR)	7.00-16C(6PR) Dual	
10,000	7.50-16C(6PR)	7.50-16C(6PR) Dual	1850-lb ea front spring; 4150-lb ea main & auxiliary rear spring
11,000	7.00-18D(8PR)	7.00-18D(8PR) Dual	11,000-lb rear axle with 5900-lb main & auxiliary spring & 2000-lb ea front spring
14,000	8-19.5D(8PR)	8-19.5E(10PR) Dual	

30 SERIES POWER TEAMS

C30 SERIES

ENGINE	TRANSMISSION	REAR AXLE CAPACITY	TYPE REAR WHEELS	AXLE RATIOS	
				Included With Axle	Optional
250 Six 292 Six	Chevrolet CH465 4-Speed	7200 lbs.	Single	4.57	4.10
			Dual	5.14	4.57
307 V8	Turbo Hydra-matic	7200 lbs.	Single	4.57	4.10
			Dual	5.14	4.57
350 V8	Chevrolet CH465 4-Speed	7200 lbs.	Single	4.10	4.57
			Dual	4.57	4.10
	New Process 435 CR	7200 lbs.	Single	4.57	4.10
			Dual	5.14	4.10, 4.57
	Turbo Hydra-matic	7200 lbs.	Single	4.10	4.57
			Dual	4.57	4.10
400 V8	Chevrolet CH465 4-Speed	7200 lbs.	Single	4.10	—
	Turbo Hydra-matic	7200 lbs.	Single	4.10	—
250 Six 292 Six 307 V8 350 V8	Chevrolet CH465 4-Speed	11000 lbs.	Dual	6.17	—

OPTIONAL ENGINE RATINGS

CE30 with 292 Six

Gross Horsepower 165 @ 4000 rpm
 Net Horsepower 125 @ 3600 rpm
 Gross Torque, lb-ft. 270 @ 1600 rpm
 Net Torque, lb-ft. 225 @ 2400 rpm

CE30 with 350 V8

Gross Horsepower 250 @ 4600 rpm
 Net Horsepower 170 @ 3600 rpm
 Gross Torque, lb-ft. 350 @ 3000 rpm
 Net Torque, lb-ft. 310 @ 2400 rpm

CE30 with 400 V8

Gross Horsepower 300 @ 4800 rpm
 Net Horsepower 240 @ 4400 rpm
 Gross Torque, lb-ft. 400 @ 3200 rpm
 Net Torque, lb-ft. 340 @ 3200 rpm

C30 SERIES—GASOLINE (6600-lb—14,000-lb GVW) 1971 MODELS WITH STANDARD EQUIPMENT

Model Number and Description	Wheel-base	Factory D & H	List Price	Mfr's Suggested Retail Price*	Destination Charge & Group Number	Total
→ 6-Cylinder 145-hp High Torque 250 Engine						
CS31002	Chassis-Cowl (120" Cowl-to-Axle)	133"	\$180.00	\$2329.00	\$2509.00	25
CS31003	Chassis-Cab (60" Cab-to-Axle)	133"	218.00	2761.00	2979.00	24
CS31004	Pickup—Stepside (9 ft)	133"	229.00	2902.00	3131.00	20
CS31034	Pickup—Fleetside (8½ ft)	133"	233.00	2959.00	3192.00	20
CS31403	Chassis-Cab (84" Cab-to-Axle)	157"	221.00	2800.00	3021.00	24
→ 8-Cylinder 215-hp High Torque 307 Engine						
CE31002	Chassis-Cowl (120" Cowl-to-Axle)	133"	189.00	2444.00	2633.00	25
CE31003	Chassis-Cab (60" Cab-to-Axle)	133"	226.00	2876.00	3102.00	24
CE31004	Pickup—Stepside (9 ft)	133"	238.00	3017.00	3255.00	20
CE31034	Pickup—Fleetside (8½ ft)	133"	242.00	3074.00	3316.00	20
CE31403	Chassis-Cab (84" Cab-to-Axle)	157"	229.00	2915.00	3144.00	24

* Manufacturer's Suggested Retail Prices do not include state and local taxes, license fees, options or accessories.

OPTIONS AND ACCESSORIES WHEN INSTALLED BY CHEVROLET

Description	Option Number	Factory D & H	List Price	Mfr's Suggested Retail Delivered Price
-------------	---------------	---------------	------------	--

MODEL OPTIONS

(See Exterior and Interior Color Charts)

<p>→ Custom Deluxe: Chassis-Cab or Pickup models only. Not available when bucket seats, Cheyenne or Cheyenne Super is ordered. Includes bright metal rear window molding; vent window and windshield moldings; cigar lighter; dual horns; bright control knob trim and dome lamp bezel; fender nameplates; full-depth foam seat with cloth trim; door trim panels; color-keyed floor mat; door operated dome lamp switches and special insulation</p>	Z62		\$ 7.60	\$100.00	\$107.60
<p>Cheyenne: Chassis-Cab or Pickup models only. Includes full-depth foam seat with deluxe vinyl trim; carpeting; door trim panels; chromed front bumper; cigar lighter; headliner; cargo area lamp; bright control knob and pedal trim; rear window, vent window and windshield moldings; Cheyenne fender nameplates; bright side marker lamp bezels; dual horns; door operated dome lamp switches and special insulation</p>	Z84		14.90	196.00	210.90
<p>Chassis-Cab or Stepside Pickup models only. Also includes body side lower molding and bright fuel filler cap</p>	Z84		17.95	236.00	253.95
<p>→ Cheyenne Super: Includes full-depth foam seat with cloth trim; carpeting; door trim panels; bright moldings and wood grained trim with Cheyenne Super nameplate on glove box cover; wood grained gauge type instrument cluster; chromed front bumper; cigar lighter; headliner; cargo area lamp; bright control knob and pedal trim; rear window, vent window and windshield moldings; Cheyenne Super fender nameplates; bright side marker lamp bezels; dual horns; door operated dome lamp switches and special insulation</p>					
<p>Chassis-Cab models</p>					
<p>Without 11,000-lb rear axle, dual rear or 10.00-16.5 tires. Also includes chromed hub caps</p>	YE9			Will Advise	
<p>With 11,000-lb rear axle, dual rear or 10.00-16.5 tires</p>	YE9			Will Advise	
<p>Stepside Pickup models only. Also includes chromed hub caps</p>	YE9			Will Advise	
<p>Fleetside Pickup models only. Also includes body side upper and lower molding plus bright fuel filler cap and tailgate latch</p>					
<p>Without 10.00-16.5 tires. Also includes chromed hub caps</p>	YE9			Will Advise	
<p>With 10.00-16.5 tires</p>	YE9			Will Advise	

POWER TEAMS AND AXLES

Engines:					
292 Six. CS30 models only	L25		6.85	90.00	96.85
350 V8. CE30 models only. Includes 4-barrel carburetor and 12" coil clutch and 4.10 ratio rear axle when Chevrolet 4-speed or Turbo Hydra-matic transmission is ordered	LS9		3.20	42.00	45.20
400 V8. CE30 models only. Includes 4.10 ratio rear axle, 12" coil clutch, 4-barrel carburetor and dual exhausts	L47		12.55	165.00	177.55
Liquid Petroleum Gas Conversion. Available only when 6-cyl or 350 V8 engine is ordered. Not available when automatic transmission is ordered. Includes internal modifications of valves, compression ratio and heat shield	L56		6.85	90.00	96.85

© State and local taxes not included.

→ Indicates Change

C30 SERIES—GASOLINE

OPTIONS AND ACCESSORIES WHEN INSTALLED BY CHEVROLET

Description	Option Number	Factory D & H	List Price	Mfr's Suggested Retail Delivered Price [◇]
Transmissions: Not available when 11,000-lb rear axle is ordered				
<i>Turbo Hydra-matic.</i> Includes park position on transmission and HD radiator				
Without 400 engine	M49	\$17.50	\$230.00	\$247.50
With 400 engine	M49	18.25	240.00	258.25
<i>New Process 435CR 4-Speed Close-Ratio.</i> CE30 models with 350 engine only	M28	2.30	30.00	32.30
Axles, Rear:				
<i>4.10 Ratio.</i> Available with single rear wheels except when 350 or 400 engine and Chevrolet 4-speed or Turbo Hydra-matic transmission is ordered. Available with dual rear wheels only when 350 engine is ordered. Not available when 11,000-lb rear axle is ordered				
	HB8	.95	12.00	12.95
<i>4.57 Ratio.</i> Available only when 350 engine and Chevrolet 4-speed or Turbo Hydra-matic transmission is ordered with single rear wheels or when 350 engine with New Process 4-speed transmission or 250, 292 or 307 engine is ordered with dual rear wheels. Not available when 11,000-lb rear axle is ordered. Included with dual rear wheels when 350 engine and Chevrolet 4-speed or Turbo Hydra-matic transmission are ordered				
	H20	.95	12.00	12.95
<i>Capacity 11,000-lb, 6.17 ratio.</i> Available only when standard transmission, HD radiator and 7.00-18/D or 8-19.5/D or 8-19.5/E dual rear tires are ordered. Not available on Pickup models or when 400 engine is ordered. Includes 2000-lb each front springs, 4000-lb front suspension, HD front and rear shock absorbers and 5900-lb each main and auxiliary rear springs				
	H22	29.60	389.00	418.60
<i>NoSPIN.</i> Not available when 11,000-lb rear axle is ordered	G86	9.50	125.00	134.50
OTHER OPTIONS				
Air Cleaner: Oil-bath. Capacity 1 quart. Available only when 250, 292 or 350 engine is ordered				
	K48	.80	10.00	10.80
Air Conditioning, All-Weather: V8 models only. Not available on Cowl models. Includes HD radiator and 42-amp generator				
	C60	30.40	400.00	430.40
Batteries: 12-volt				
→ <i>Auxiliary.</i> 53-amp-hr, 9-plate	TP2	3.45	45.00	48.45
<i>Heavy-Duty.</i> 80-amp-hr, 15-plate	T60	1.25	16.00	17.25
Belts, Seat: Installed for third passenger. Not available on Cowl models or when bucket seats are ordered				
	AM3	.50	6.50	7.00
Box, Tool Storage: Fleetside Pickup models only. Includes 7" high, 28" wide and 17" deep reinforced plastic box with bottom hinge and separate key located on RH side forward of rear wheelhousing				
	VK2	3.45	45.00	48.45
Bumpers: Chassis-Cab or Pickup models only				
<i>Painted</i>				
Rear. Pickup models with standard painted front bumper only	V38	1.70	22.00	23.70
Rear step. Pickup models only	V43	3.65	48.00	51.65
→ <i>Chromed</i>				
Front and rear. Pickup models only. Not available when Cheyenne or Cheyenne Super is ordered	V37	3.80	50.00	53.80
Front. Included when Cheyenne or Cheyenne Super is ordered	V46	1.15	15.00	16.15
Rear. Pickup models with Cheyenne or Cheyenne Super only	VF1	2.70	35.00	37.70
→ Caps, Hub: Chromed. Not available when dual rear wheels, 10.00-16.5/C tires or 11,000-lb rear axle is ordered. Included when Cheyenne Super is ordered				
	P03	.80	10.00	10.80
Carrier, Spare Wheel:				
Chassis-Cab models with dual rear wheels or Cowl models only (Under frame mounting)				
	P10	.80	10.00	10.80
Fleetside Pickup models only (Side mounted)	P13	1.10	14.00	15.10
Stepside Pickup models only (Side mounted)				
Without chromed hub caps	P13	1.25	16.00	17.25
With chromed hub caps	P13	1.40	18.25	19.65
Cooling: HD radiator only. Included when air conditioning or automatic transmission is ordered				
	V01	1.90	25.00	26.90

◇ State and local taxes not included

→ Indicates Change

C30 SERIES—GASOLINE

OPTIONS AND ACCESSORIES WHEN INSTALLED BY CHEVROLET

Description	Option Number	Factory D & H	List Price	Mfr's Suggested Retail Delivered Price [⊖]
→ Gauges: Chassis-Cab or Pickup models only				
<i>Ammeter, temperature and oil pressure.</i> Included when Cheyenne Super is ordered	Z53	\$.95	\$12.00	\$12.95
<i>Tachometer</i>				
Without Cheyenne Super. Also includes ammeter, temperature and oil pressure gauges	U16	4.20	55.00	59.20
With Cheyenne Super	U16	Will Advise		
Generators:				
<i>42-amp Delcotron.</i> Included on Chassis-Cab or Pickup models when air conditioning, dual rear wheels or stake body is ordered	K79	1.70	22.00	23.70
<i>61-amp Delcotron.</i> Included on Chassis-Cab models when combination of stake body or dual rear wheels and air conditioning are ordered	K76	2.30	30.00	32.30
Glass, Soft-Ray: All windows. Chassis-Cab or Pickup models only	A11	1.40	18.00	19.40
Guards, Door Edge: Chassis-Cab or Pickup models only	B93	.50	6.00	6.50
Harness, Camper Body Wiring: For camper body installation on Pickup models only	UY1	1.15	15.00	16.15
Hooks, Towing: Two, front. Not available with chromed bumper	V76	1.40	18.00	19.40
Lamps:				
→ Cargo Area. Chassis-Cab or Pickup models only. Included when Cheyenne or Cheyenne Super is ordered	UF2	1.45	19.00	20.45
<i>Roof Marker, Five.</i> Not available on Cowl models or when stake body or dual rear wheels are ordered	U01	1.90	25.00	26.90
→ Lighter, Cigar: Included when custom deluxe, Cheyenne or Cheyenne Super is ordered	U37	.40	5.00	5.40
Mirrors, Exterior: Replaces standard LH and RH mirrors. Chassis-Cab or Pickup models only				
<i>Below-Eye-Line Type.</i> Not available when stake body is ordered				
7.5" x 10.5" painted	D29	1.50	19.50	21.00
7.5" x 10.5" stainless steel	DG4	2.70	35.00	37.70
<i>Camper Type</i>				
Painted	DF1	1.50	19.50	21.00
Stainless steel	DF2	3.75	49.00	52.75
<i>Senior West Coast Type.</i>				
	DGS	2.70	35.00	37.70
→ Moldings, Custom: Fleetside Pickup models only				
<i>Lower fender, door, cab panel and pickup box moldings plus bright fuel filler cap.</i> Included when Cheyenne, Cheyenne Super or deluxe two-tone paint is ordered				
Without upper moldings (Option B85)	BX2	3.45	45.00	48.45
With upper moldings (Option B85)	BX2	3.05	40.00	43.05
<i>Upper fender, door, cab panel and pickup box moldings and bright fuel filler cap.</i> Not available when optional paint stripe is ordered. Included when Cheyenne Super is ordered				
Without Cheyenne	B85	3.45	45.00	48.45
With Cheyenne	B85	3.05	40.00	43.05
Nameplate, Custom Camper:				
<i>With Single Rear Wheels.</i> Available only when front stabilizer, HD shock absorbers, HD rear or auxiliary rear springs and 9.50-16.5/D or 9.50-16.5/E tubeless or 7.50-16/E tube-type tires are ordered				
CS-CE31003-04-34 models only	Z81	N.C.	N.C.	N.C.
CS-CE31403 models only. Includes extended tailpipe				
Without 400 engine	Z81	.80	10.00	10.80
With 400 engine	Z81	1.55	20.00	21.55
<i>With Dual Rear Wheels and 7200-lb Rear Axle.</i> Available only when front stabilizer, HD shock absorbers, HD rear or auxiliary rear springs and minimum of 7.00-16/C tube-type tires are ordered				
CS-CE31003 models only	Z81	N.C.	N.C.	N.C.
CS-CE31403 models only. Includes extended tailpipe				
Without 400 engine	Z81	.80	10.00	10.80
With 400 engine	Z81	1.55	20.00	21.55
<i>With Dual Rear Wheels and 11,000-lb Rear Axle.</i> Available only when front stabilizer and minimum of 7.00-18/D tube-type or 8-19.5/D tubeless tires are ordered				
CS-CE31003 models only	Z81	N.C.	N.C.	N.C.
CS-CE31403 models only. Includes extended tailpipe				
Without 400 engine	Z81	.80	10.00	10.80
With 400 engine	Z81	1.55	20.00	21.55

⊖ State and local taxes not included.

→ Indicates Change

C30 SERIES—GASOLINE

OPTIONS AND ACCESSORIES WHEN INSTALLED BY CHEVROLET

Description	Option Number	Factory D & H	List Price	Mfr's Suggested Retail Delivered Price [⊕]
Paints, Exterior: See Color and Trim Chart				
Solid		N.C.	N.C.	N.C.
Conventional Two-Tone. With white secondary color. Chassis-Cab or Pickup models only		\$ 1.90	\$ 25.00	\$ 26.90
Custom Two-Tone. Chassis-Cab or Pickup models only		1.90	25.00	26.90
→ Deluxe Two-Tone. Cab roof and area between upper and lower moldings painted white. Fleetside Pickup models only.				
Without Cheyenne or Cheyenne Super. Available only when custom upper moldings are ordered. Includes custom lower moldings		8.75	115.00	123.75
With Cheyenne. Available only when custom upper moldings are ordered		5.70	75.00	80.70
With Cheyenne Super		5.70	75.00	80.70
Plates: Serial Number (State of Pennsylvania) Chassis-Cab or Cowl models only.				
"K" Plate. Available only when 1850-lb each front springs, dual rear wheels and 3100-lb each or 4150-lb each rear springs are ordered	Z74	N.C.	N.C.	N.C.
"T" Plate. Available only when 11,000-lb rear axle is ordered	Z74	N.C.	N.C.	N.C.
Radies: Pushbutton control. Chassis-Cab or Pickup models only. Includes manual front antenna				
AM	U63	4.95	65.00	69.95
AM/FM	U69	10.75	141.00	151.75
→ Seats: Chassis-Cab or Pickup models only				
Bucket, Driver and Passenger. Includes carpeting and console				
Without Cheyenne or Cheyenne Super	A50	10.50	138.00	148.50
With Cheyenne	A50	8.60	113.00	121.60
With Cheyenne Super	A50	Will Advise		
Full-Depth Foam. Not available when custom deluxe, Cheyenne or Cheyenne Super is ordered	Z52	2.15	28.00	30.15
Shock Absorbers, Heavy-Duty: Included when 11,000-lb rear axle is ordered				
Front and Rear	F51	2.45	32.00	34.45
Rear	G68	1.90	25.00	26.90
Springs: Not available when 11,000-lb rear axle is ordered				
Front. Capacity 1850-lb each	F60	.50	6.00	6.50
Rear				
Capacity 3100-lb each	G50	1.40	18.00	19.40
Capacity 4150-lb each; main and auxiliary	G60	3.05	40.00	43.05
Stabilizer, Front	F59	1.40	18.00	19.40
Stake Body: 9-ft. CS-CE31003 models only. Not available when below-eye-line mirrors are ordered. Includes (2) rear side marker lamps, (5) cab marker lamps, (3) rear identification lamps, (2) rear clearance lamps and 42-amp generator when air conditioning is not ordered or 61-amp generator when air conditioning is ordered				
	E56	30.25	398.00	428.25
Steering, Power	N40	9.50	125.00	134.50
Steering Wheel, Comfortilt	N33	4.20	55.00	59.20
Stripes, Body Side Paint	D89	1.00	13.00	14.00
Support, Heavy-Duty Cross Hill: Chassis-Cab models only. Not available when stake body is ordered				
CS-CE31003 models only	F19	1.40	18.00	19.40
CS-CE31403 models only	F19	2.15	28.00	30.15
→ Switches, Dome Lamp: Door operated. Included when custom deluxe, Cheyenne or Cheyenne Super is ordered				
	C80	.35	4.00	4.35
Throttle Control: Manual	K31	1.10	14.00	15.10
Tires and Wheels: See following pages				
Window, Sliding Rear: Chassis-Cab or Pickup models only	A28	3.80	50.00	53.80

⊕ State and local taxes not included.

→ Indicates Change

C30 SERIES—GASOLINE

TUBE-TYPE TIRES (Factory Installed)

X

Tire Size and Type	Rim Width Included In Tire Option	Option Number	Factory D & H	List Price	Mfr's Suggested Retail Delivered Price [⊕]
<small>Note: Front and rear tires must be of the same rim width and diameter except when 10.00-16.5/C rear tires are ordered.</small>					

DEALER NOTE: When dual rear tires are specified, the following equipment will be applied to the order as shown in the dual rear tire portion of the order form.

THIS EQUIPMENT IS NOT PRICED IN THE TIRE OPTION AND WILL REFLECT ON THE INVOICE IN THE FOLLOWING MANNER:

Includes dual rear chassis provisions and 4.57 ratio 7200-lb rear axle when 350 engine with Chevrolet 4-speed or Turbo Hydra-matic transmission is ordered. Also includes 5.14 ratio 7200-lb rear axle when 350 engine with New Process 4-speed close-ratio transmission or 250, 292 or 307 engine is ordered

Cowl models.....	R05		\$.80	\$ 10.00	\$ 10.80
Chassis-Cab models without option E56 stake body. Also includes 42-amp generator when air conditioning is not ordered or 61-amp generator when air conditioning is ordered, (5) cab marker lamps and spare wheel carrier deletion.....	R05		3.80	50.00	53.80
Chassis-Cab models with option E56 stake body. Also includes spare wheel carrier deletion.....	R05		N.C.	N.C.	N.C.
6.50-16/C (6PR) Maximum Tire Capacity (Each)—Front (1610) Dual Rear (1420)					
—Highway Nylon (2) Front.....	5.50	R65	N.C.	N.C.	N.C.
(6) Front and dual rear (Chassis-Cab only).....	5.50	R65	10.40	116.50	126.90
(6) Front and dual rear (Cows only).....	5.50	R65	11.20	127.00	138.20
(1) Spare.....	5.50	R65	6.25	64.50	70.75
7.00-16/C (6PR) Maximum Tire Capacity (Each)—Front (1800) Dual Rear (1580)					
—Highway Nylon (2) Front.....	5.50	R78	N.C.	N.C.	N.C.
(4) Dual rear (Chassis-Cab only).....	5.50	R78	12.00	119.50	131.50
(4) Dual rear (Cows only).....	5.50	R78	12.80	130.00	142.80
(1) Spare.....	5.50	R78	6.80	67.50	74.30
—On-Off Road Nylon (4) Dual rear (Chassis-Cab only).....	5.50	R71	15.55	168.50	184.05
(4) Dual rear (Cows only).....	5.50	R71	16.35	179.00	195.35
(1) Spare.....	5.50	R71	7.65	79.00	86.65
7.50-16/C (6PR) Maximum Tire Capacity (Each)—Front (2060) Rear (2060) Dual Rear (1815)					
—Highway Nylon (2) Front (with single rear wheels).....	6.00	R67	1.30	19.50	20.80
(2) Front (with dual rear wheels).....	5.50	R67	1.35	20.50	21.85
(2) Single rear (except Cows).....	6.00	R67	1.85	27.00	28.85
(2) Single rear (Cows only).....	6.00	R67	1.30	19.50	20.80
(4) Dual rear (Chassis-Cab only).....	5.50	R67	15.75	163.00	178.75
(4) Dual rear (Cows only).....	5.50	R67	16.55	173.50	190.05
(1) Spare (with single rear wheels—except Cows).....	6.00	R67	6.20	58.00	64.20
(1) Spare (with single rear wheels—Cows only).....	6.00	R67	7.60	76.00	83.60
(1) Spare (with dual rear wheels).....	5.50	R67	7.60	76.50	84.10
—On-Off Road Nylon (2) Single rear (except Cows).....	6.00	RM7	3.70	50.00	53.70
(2) Single rear (Cows only).....	6.00	RM7	3.15	42.50	45.65
(4) Dual rear (Chassis-Cab only).....	5.50	RM7	19.40	208.00	227.40
(4) Dual rear (Cows only).....	5.50	RM7	20.20	218.50	238.70
(1) Spare (with single rear wheels—except Cows).....	6.00	RM7	7.10	69.00	76.10
(1) Spare (with single rear wheels—Cows only).....	6.00	RM7	8.45	87.00	95.45
(1) Spare (with dual rear wheels).....	5.50	RM7	8.50	87.50	96.00

⊕ State and local taxes not included.

C30 SERIES—GASOLINE

TUBE-TYPE TIRES (Factory Installed)

Tire Size and Type <small>Note: Front and rear tires must be of the same rim width and diameter except when 10.00-16.5/C rear tires are ordered.</small>	Rim Width Included In Tire Option	Option Number	Factory D & H	List Price	Mfr.'s Suggested Retail Delivered Price [⊙]
---	-----------------------------------	---------------	---------------	------------	--

Dealer Note: When dual rear tires are specified, following equipment will be applied to the order as shown in the dual rear tire portion of the order form.

THIS EQUIPMENT IS NOT PRICED IN THE TIRE OPTION AND WILL REFLECT ON THE INVOICE IN THE FOLLOWING MANNER:

Includes dual rear chassis provisions and 4.57 ratio 7200-lb rear axle when 350 engine with Chevrolet 4-speed or Turbo Hydra-matic transmission is ordered. Also includes 5.14 ratio 7200-lb rear axle when 350 engine with New Process 4-speed close-ratio transmission or 250, 292 or 307 engine is ordered.

Cowl models.....	R05		\$.80	\$ 10.00	\$ 10.80
Chassis-Cab models without option E56 stake body. Also includes 42-amp generator when air conditioning is not ordered or 61-amp generator when air conditioning is ordered, (5) cab marker lamps and spare wheel carrier deletion.....	R05		3.80	50.00	53.80
Chassis-Cab models with option E56 stake body. Also includes spare wheel carrier deletion.....	R05		N.C.	N.C.	N.C.

7.50-16/D (8PR) Maximum Tire Capacity (Each)—Front (2440) Rear (2440) Dual Rear (2140)

—Highway Nylon	(2) Front (with single rear wheels).....	6.00	R68	2.20	29.00	31.20
	(2) Front (with dual rear wheels).....	5.50	R68	2.25	30.00	32.25
	(2) Single rear (except Cows).....	6.00	R68	2.75	36.50	39.25
	(2) Single rear (Cows only).....	6.00	R68	2.20	29.00	31.20
	(4) Dual rear (Chassis-Cab only).....	5.50	R68	17.30	178.50	195.80
	(4) Dual rear (Cows only).....	5.50	R68	18.10	189.00	207.10
	(1) Spare (with single rear wheels—except Cows).....	6.00	R68	6.55	61.00	67.55
	(1) Spare (with single rear wheels—Cows only).....	6.00	R68	7.90	79.00	86.90
	(1) Spare (with dual rear wheels).....	5.50	R68	7.95	79.50	87.45
—On-Off Road Nylon	(2) Single rear (except Cows).....	6.00	RM8	4.75	61.50	66.25
	(2) Single rear (Cows only).....	6.00	RM8	4.20	54.00	58.20
	(4) Dual rear (Chassis-Cab only).....	5.50	RM8	21.25	227.50	248.75
	(4) Dual rear (Cows only).....	5.50	RM8	22.05	238.00	260.05
	(1) Spare (with single rear wheels—except Cows).....	6.00	RM8	7.50	73.00	80.50
	(1) Spare (with single rear wheels—Cows only).....	6.00	RM8	8.85	91.00	99.85
	(1) Spare (with dual rear wheels).....	5.50	RM8	8.90	91.50	100.40

7.50-16/E (10PR) Maximum Tire Capacity (Each)—Front (2780) Rear (2780)

—Highway Nylon	(4) Front & rear (except Cows).....	6.00	RM5	9.15	109.50	118.65
	(4) Front & rear (Cows only).....	6.00	RM5	8.50	102.00	110.60
	(2) Front.....	6.00	RM5	4.30	51.00	55.30
	(1) Spare (except Cows).....	6.00	RM5	7.75	74.00	81.75
	(1) Spare (Cows only).....	6.00	RM5	9.10	92.00	101.10
—On-Off Road Nylon	(2) Rear (except Cows).....	6.00	RM6	7.20	88.50	95.70
	(2) Rear (Cows only).....	6.00	RM6	6.65	81.00	87.65
	(1) Spare (except Cows).....	6.00	RM6	8.85	88.50	97.35
	(1) Spare (Cows only).....	6.00	RM6	10.25	106.50	116.75

7.00-18/D (8PR) Maximum Tire Capacity (Each)—Front (2590) Dual Rear (2270)

—Highway Nylon	(6) Front & dual rear (Chassis-Cab only).....	5.00	R90	24.30	257.50	281.80
	(6) Front & dual rear (Cows only).....	5.00	R90	25.10	268.00	293.10
	(1) Spare.....	5.00	R90	9.45	97.00	106.45

⊙ State and local taxes not included.

C30 SERIES—GASOLINE

WIDE BASE TUBELESS TIRES (Factory Installed)

Tire Size and Type	Rim Width Included In Tire Option	Option Number	Factory D & H	List Price	Mfr's Suggested Retail Delivered Price [⊕]
--------------------	-----------------------------------	---------------	---------------	------------	---

Note: Front and rear tires must be of the same rim width and diameter except when 10.00-16.5/C rear tires are ordered.

Dealer Note: When dual rear tires are specified, the following equipment will be applied to the order as shown in the dual rear tire portion of the order form.

THIS EQUIPMENT IS NOT PRICED IN THE TIRE OPTION AND WILL REFLECT ON THE INVOICE IN THE FOLLOWING MANNER:

Includes dual rear chassis provisions and 4.57 ratio 7200-lb rear axle when 350 engine with Chevrolet 4-speed or Turbo Hydra-matic transmission is ordered. Also includes 5.14 ratio 7200-lb rear axle when 350 engine with New Process 4-speed close-ratio transmission or 250, 292 or 307 engine is ordered.

Cowl models	R05		\$.80	\$ 10.00	\$ 10.80
Chassis-Cab models without option E56 stake body. Also includes 42-amp generator when air conditioning is not ordered or 61-amp generator when air conditioning is ordered, (5) cab marker lamps and spare wheel carrier deletion	R05		3.80	50.00	53.80
Chassis-Cab models with option E56 stake body. Also includes spare wheel carrier deletion	R05		N.C.	N.C.	N.C.

8.00-16.5/D (8PR) Maximum Tire Capacity (Each)—Front (2045) Dual Rear (1800)					
—Highway	(6) Front & dual rear				
Nylon	(Chassis-Cab only)	6.00	RP3	17.75	192.50 210.25
	(6) Front & dual rear				
	(Cows only)	6.00	RP3	18.55	203.00 221.55
	(1) Spare	6.00	RP3	8.20	84.50 92.70

8.75-16.5/C (6PR) Maximum Tire Capacity (Each)—Front (1990) Rear (1990)					
—Highway	(2) Front	6.00	Std	N.C.	N.C. N.C.
Nylon	(2) Rear	6.00	Std	N.C.	N.C. N.C.
	(1) Spare (except Cows)	6.00	RP5	6.95	66.00 72.95
	(1) Spare (Cows only)	6.00	RP5	7.70	76.50 84.20
—On-Off Road	(2) Rear	6.00	RP2	1.65	21.00 22.65
Nylon	(1) Spare (except Cows)	6.00	RP2	8.30	84.00 92.30
	(1) Spare (Cows only)	6.00	RP2	9.10	94.50 103.60

8.75-16.5/D (8PR) Maximum Tire Capacity (Each)—Front (2350) Rear (2350)					
—Highway	(2) Front	6.00	RP6	1.45	19.00 20.45
Nylon	(2) Rear	6.00	RP6	1.45	19.00 20.45
	(1) Spare (except Cows)	6.00	RP6	7.55	74.00 81.55
	(1) Spare (Cows only)	6.00	RP6	8.35	84.50 92.85
—On-Off Road	(2) Rear	6.00	RQ4	2.95	40.00 42.95
Nylon	(1) Spare (except Cows)	6.00	RQ4	8.25	84.00 92.25
	(1) Spare (Cows only)	6.00	RQ4	9.05	94.50 103.55

9.50-16.5/D (8PR) Maximum Tire Capacity (Each)—Front (2780) Rear (2780)					
—Highway	(2) Front	6.75	RP9	4.05	48.00 52.05
Nylon	(2) Rear (except Cows)	6.75	RP9	4.30	51.00 55.30
	(2) Rear (Cows only)	6.75	RP9	4.05	48.00 52.05
	(1) Spare (except Cows)	6.75	RP9	8.70	87.00 95.70
	(1) Spare (Cows only)	6.75	RP9	9.75	100.50 110.25
—On-Off Road	(2) Rear (except Cows)	6.75	RQ5	5.50	72.00 77.50
Nylon	(2) Rear (Cows only)	6.75	RQ5	5.30	69.00 74.30
	(1) Spare (except Cows)	6.75	RQ5	9.30	97.00 106.30
	(1) Spare (Cows only)	6.75	RQ5	10.35	110.50 120.85

9.50-16.5/E (10PR) Maximum Tire Capacity (Each)—Front (3170) Rear (3170)					
—Highway	(2) Front	6.75	RQ6	7.90	101.00 108.90
Nylon	(2) Rear (except Cows)	6.75	RQ6	8.10	104.00 112.10
	(2) Rear (Cows only)	6.75	RQ6	7.90	101.00 108.90
	(1) Spare (except Cows)	6.75	RQ6	9.25	95.00 104.25
	(1) Spare (Cows only)	6.75	RQ6	10.25	108.50 118.75
—On-Off Road	(2) Rear (except Cows)	6.75	RQ7	9.50	125.00 134.50
Nylon	(2) Rear (Cows only)	6.75	RQ7	9.30	122.00 131.30
	(1) Spare (except Cows)	6.75	RQ7	9.90	105.00 114.90
	(1) Spare (Cows only)	6.75	RQ7	10.90	118.50 129.40

⊕ State and local taxes not included.

C30 SERIES—GASOLINE

TUBELESS TIRES (Factory Installed)

Tire Size and Type	Rim Width Included In Tire Option	Option Number	Factory D & H	List Price	Mfr's Suggested Retail Delivered Price [⊕]
--------------------	-----------------------------------	---------------	---------------	------------	---

Note: Front and rear tires must be of the same rim width and diameter except when 10.00-16.5/C rear tires are ordered.

Dealer Note: When dual rear tires are specified, following equipment will be applied to the order as shown in the dual rear tire portion of the order form.

THIS EQUIPMENT IS NOT PRICED IN THE TIRE OPTION AND WILL REFLECT ON THE INVOICE IN THE FOLLOWING MANNER:

Includes dual rear chassis provisions and 4.57 ratio 7200-lb rear axle when 350 engine with Chevrolet 4-speed or Turbo Hydra-matic transmission is ordered. Also includes 5.14 ratio 7200-lb rear axle when 350 engine with New Process 4-speed close-ratio transmission or 250, 292 or 307 engine is ordered.

Cowl models.....	R05		\$.80	\$ 10.00	\$ 10.80
Chassis-Cab models without option E56 stake body. Also includes 42-amp generator when air conditioning is not ordered or 61-amp generator when air conditioning is ordered. (5) cab marker lamps and spare wheel carrier deletion.....	R05		3.80	50.00	53.80
Chassis-Cab models with option E56 stake body. Also includes spare wheel carrier deletion.....	R05		N.C.	N.C.	N.C.

▲8-19.5/D (8PR) Maximum Tire Capacity (Each)—Front (2800) Dual Rear (2460)					
—Highway Nylon	(2) Front.....	5.25	R98		
	(6) Front & dual rear (Chassis-Cab only)	5.25	R98	4.30	45.00
	(6) Front & dual rear (Cows only)	5.25	R98	27.95	283.50
	(1) Spare.....	5.25	R98	28.75	294.00
—On-Off Road Nylon	(4) Dual Rear (except Cows)	5.25	R97	10.10	102.00
	(4) Dual Rear (Cows only)	5.25	R97	29.40	295.50
	(1) Spare.....	5.25	R97	30.20	306.00
				11.50	116.00

▲8-19.5/E (10PR) Maximum Tire Capacity (Each)—Front (3170) Dual Rear (2780)					
—Highway Nylon	(2) Front.....	5.25	R99		
	(4) Dual rear (Chassis-Cab only)	5.25	R99	7.65	95.00
	(4) Dual rear (Cows only)	5.25	R99	29.90	332.50
	(1) Spare.....	5.25	R99	30.70	343.00
				11.55	124.00

TUBELESS FLOTATION-TYPE TIRES (Factory Installed)

Requires use of 8.75-16.5, 7.50-16/C or 7.50-16/D or flotation-type tubeless front tires.

★ 10.00-16.5/C (6PR) Maximum Tire Capacity (Each)—Front (2330) Rear (2330)					
—Highway Nylon	(2) Front.....	8.25	R79		
	◆ (2) Rear (except Cows).....	8.25	R79	6.60	96.00
	(2) Rear (Cows only).....	8.25	R79	5.80	85.50
	● (1) Spare (except Cows).....	●	R79	6.60	96.00
	(1) Spare (Cows only).....	8.25	R79	8.45	91.00
—On-Off Road Nylon	◆ (2) Rear (except Cows).....	8.25	RR2	10.95	124.00
	(2) Rear (Cows only).....	8.25	RR2	7.00	106.50
	● (1) Spare (except Cows).....	●	RR2	7.80	117.00
	(1) Spare (Cows only).....	8.25	RR2	9.05	101.00
				11.55	134.00

SPARE WHEELS

Wheel Type	Option Number	Factory D & H	List Price	Mfr's Suggested Retail Delivered Price [⊕]
<i>For tube-type tires</i>				
16" x 5.50".....	S76	\$ 1.45	\$18.50	\$19.95
16" x 6.00".....	Q20	1.40	18.00	19.40
18" x 5.00".....	Q31	1.60	21.00	22.60
<i>For tubeless tires</i>				
16.5" x 6.00"				
Cowl models only				
With 8.00-16.5 dual rear tires.....	QE6	1.45	18.50	19.95
With 8.75-16.5 single rear tires.....	QE6	.80	10.50	11.30
Chassis-Cab or Fleetside Pickup models				
With 10.00-16.5 single rear tires only.....	QE6	.80	10.50	11.30
With 8.00-16.5 dual rear tires.....	QE6	1.45	18.50	19.95
16.5" x 6.75". Cowl models only with 9.50-16.5 rear tires.....	QE7	.95	12.00	12.95
16.5" x 8.25".....	S89	2.55	33.00	35.55
19.5" x 5.25".....	Q36	2.00	26.00	28.00

★ This size not available on Stepside Pickup models.

▲ Available only when 11,000-lb rear axle is ordered.

◆ Available only when 8.75 or 10.00-16.5 tubeless or 7.50-16 tube-type highway front tires are ordered. Optional spare wheel mandatory and must match either front or rear wheels. Production spare wheel deleted.

● Option S89 spare wheel mandatory.

⊕ State and local taxes not included.