

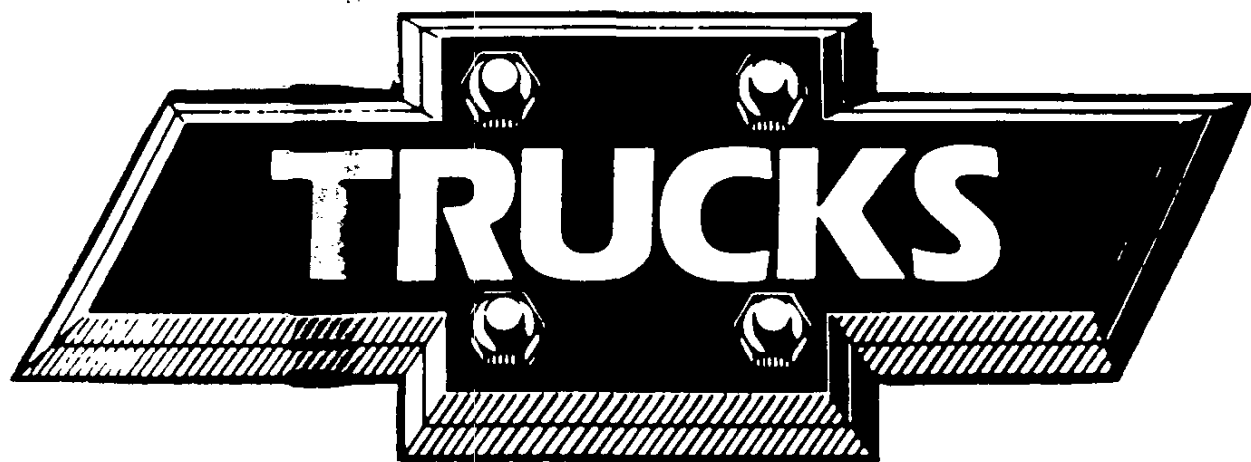

CHEVROLET



1984



C/K PICKUP
PICKUP MODEL SELECTOR
REGULAR CAB

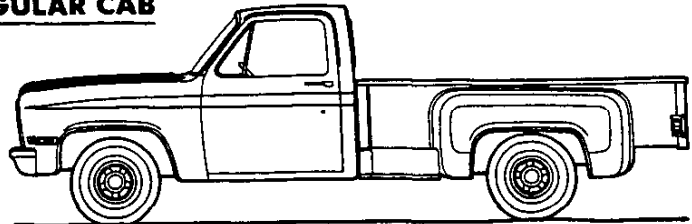
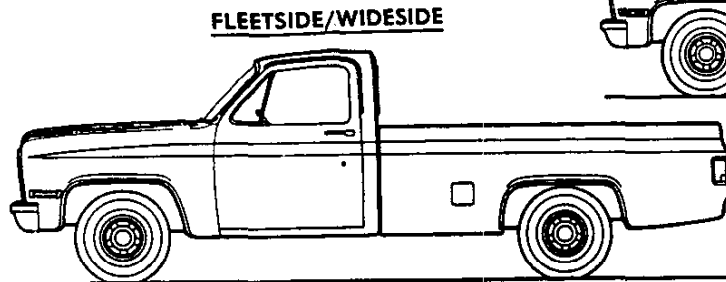

SERIES	MODEL NUMBER		BODY ORDERING CODE			
			GASOLINE MODELS		DIESEL MODELS	
	6½' BOX	8' BOX	FLEETSIDE/ WIDESIDE	STEPSIDE/ FENDERSIDE	FLEETSIDE/ WIDESIDE	STEPSIDE/ FENDERSIDE
C10/1500	C10703	C10903	E63	*E62	E63/B3J	*E62/B3J
C20/2500	—	C20903	E63	E62	E63/B3J	E62/B3J
C20/2500/C6P	—	C20903	E63/C6P	E62/C6P	E63/C6P/B3J	E62/C6P/B3J
C30/3500	—	C30903	E63	E62	E63/B3J	E62/B3J
K10/1500 (4X4)	K10703	K10903	E63	*E62	E63/B3J	*E62/B3J
K20/2500 (4X4)	—	K20903	E63	E62	E63/B3J	E62/B3J
K20/2500/C6P (4X4)	—	K20903	E63/C6P	E62/C6P	E63/C6P/B3J	E62/C6P/B3J
K30/3500 (4X4)	—	K30903	E63	—	E63/B3J	—

*Available on C/K10703 models only.

BONUS CAB AND CREW CAB

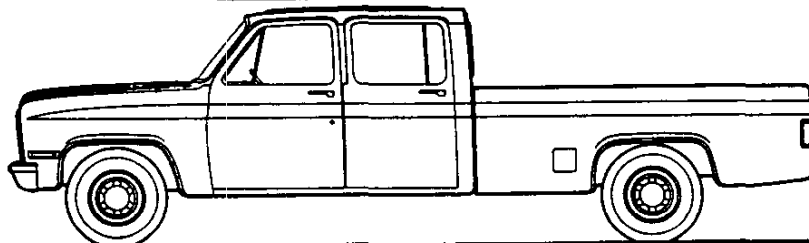

SERIES	MODEL NUMBER		BODY ORDERING CODE	
			GASOLINE MODELS	DIESEL MODELS
	BONUS CAB	CREW CAB	8' FLEETSIDE/ WIDESIDE BOX	8' FLEETSIDE/ WIDESIDE BOX
C20/2500	C20943	—	E63/YG4	E63/YG4/B3J
	—	C20943	E63/AS3	E63/AS3/B3J
C30/3500	C30943	—	E63/YG4	E63/YG4/B3J
	—	C30943	E63/AS3	E63/AS3/B3J
K30/3500 (4X4)	K30943	—	E63/YG4	E63/YG4/B3J
	—	K30943	E63/AS3	E63/AS3/B3J

GASOLINE**C/K PICKUP—2-Wheel Drive****C10/1500 REGULAR CABS****STANDARD SPECIFICATIONS**

(See Gray Tab Section for Specification Details)

Series	C10/1500
Engine	
Base Equip.	4.1 Liter, 250 2-bbl L6
Clutch	11"; 124 sq. in.
Air Filter	Oiled-paper Element
Oil Filter	Throwaway Type
Exhaust System	Single; Aluminized
Emission Control Systems	See Engine & Cooling Section for specific model applications
Suspension, Front	Independent; Coil Springs
Capacity	2950 lb.
Springs @ Ground	1475 lb. ea.
Shock Absorbers	25mm dia.
Suspension, Rear	Salisbury Axle; Hypoid Drive; Two-stage Multi-leaf Springs
Axle Capacity	3750 lb.
Axle Ratio	2.73
Springs @ Ground	1550 lb. ea.
Shock Absorbers	25mm dia.
Brakes	Hydraulic; Self-adjusting
Front	Disc; 11.86" Rotor
Rear	Drum; 11" x 2"
Booster	—
Parking	Cable to Rear Wheels
Electrical	12 Volt; Negative Ground
Battery—Freedom Type	405 CCA ♦ @ 0°F.
—Reserve Capacity	75 min. @ 80°F.
Delcotron Generator	37 amp.
Frame	Carbon Steel; 36,39,000 psi
Section Modulus	3.10
Fuel Tank (nominal capacity)	
—1175" WB	16 gal.
—1315" WB	20 gal.
Steering Gear Type	Manual; Recirculating Ball Gear
Linkage	Parallelogram
Transmission	Fully Synchronized 3-Speed Manual
Shift Location	Steering Column
Tires	(5) P195/75R15 Fiberglass Belted Radial (4PR)
Wheels	(5) Disc 15" x 6"

♦ CCA—Cold Cranking Amps

C/K PICKUP—2-Wheel Drive

DIESEL

C10/1500 REGULAR CABS STANDARD SPECIFICATIONS

(See Gray Tab Section for Specification Details)

Series	C10/1500
Engine Base Equip. Clutch Air Filter Oil Filter Oil Cooler Exhaust System Emission Control Systems	6.2 Liter, 379 Cu. In. V8 Diesel 12"; 150 sq. in. Poly-wrapped, Oiled-paper Element Thruway Type Standard Dual; Aluminized See Engine & Cooling Section for specific model applications
Suspension, Front Capacity Springs @ Ground Shock Absorbers	Independent; Coil Springs 3400 lb. 1700 lb. ea. 25mm dia.
Suspension, Rear Axle Capacity Axle Ratio Springs @ Ground Shock Absorbers	Salisbury Axle; Hypoid Drive; Two-stage Multi-leaf Springs 3750 lb. 2.73 1550 lb. ea. 25mm dia.
Brakes Front Rear Booster Parking	Hydraulic; Self-adjusting Disc; 11.86" Rotor Drum; 11" x 2" Hydraulic Power Cable to Rear Wheels
Electrical Battery—Freedom Type —Reserve Capacity Delcotron Generator Engine Block Heater	12 Volt; Negative Ground Two; 550 CCA* ea. @ 0°F. 115 min. ea. @ 80°F. 66 amp. 600 watts, 120 volts
Frame Section Modulus	Carbon Steel; 36,39,000 psi 3.10
Fuel Tank (nominal capacity) —117.5" WB —131.5" WB	16 gal. 20 gal.
Steering Gear Type	Integral Power
Transmission Shift Location	4-Speed Manual with Overdrive Floor
Tires	(5) P205/75R15 Steel Belted Radial (4PR)
Wheels	(5) Disc 15" x 6"

*CCA—Cold Cranking Amps

GASOLINE

C/K PICKUP—2-Wheel Drive

C20/2500 REGULAR CABS

C20/2500 BONUS CABS & CREW CABS

STANDARD SPECIFICATIONS

(See **Body** Tab Section for Specification Details)

Series	C20/2500 Regular Cab	C20/2500/C6P Regular Cab	C20/2500 Bonus/Crew Cab
Engine	4.8 Liter, 250 2-bbl. L6		
Base Equip.	4.8 Liter, 292 1-bbl. L6		
Clutch	11"; 124 sq. in.		
Air Filter	Oiled-paper Element		
Oil Filter	Throwaway Type		
Exhaust System	Single; Aluminized		
Emission Control Systems	See Engine & Cooling Section for specific model applications		
Suspension, Front	Independent; Coil Springs		
Capacity	3800 lb.		
Springs @ Ground	1750 lb. ea.	1900 lb. ea.	1900 lb. ea.
Shock Absorbers	25mm dia.	32mm dia.	32mm dia.
Stabilizer Bar	—	1.06" dia.	1.06" dia.
Suspension, Rear	Salisbury Axle; Hypoid Drive; Two-stage Multi-leaf Springs		
Axle Capacity	5700 lb.	6000 lb.	7500 lb.
Axle Ratio	3.42	4.10	4.10
Springs @ Ground	2000 lb. ea.	3000 lb. ea.	3000 lb. ea.
Shock Absorbers	25mm dia.	32mm dia.	32mm dia.
Brakes	Hydraulic; Self-adjusting		
Front	Disc; 12.5" Rotor		
Rear	Drum; 11.15" x 2.75"	Drum; 13" x 2.5"	
Booster	Dual Diaphragm		
Parking	Cable to Rear Wheels		
Electrical	12 Volt; Negative Ground		
Battery—Freedom Type	405 CCA ♦ @ 0°F.		
—Reserve Capacity	75 min. @ 80°F.		
Delcotron Generator	37 amp.		
Frame	Carbon Steel; 36,-39,000 psi		
Section Modulus	3.57	4.53	7.33
Fuel Tank (nominal capacity)	20 gal.		
Steering Gear Type	Manual; Recirculating Ball Gear		
Linkage	Parallelogram		
Transmission	4-Speed Manual		
Shift Location	Floor		
Tires	(4) LT 215/85R16C (6PR)	Front: LT 235/85R16D (8PR) Rear: LT 235/85R16E (10PR)	
Wheels	(4) Disc		
Size	16" x 6.5"		

♦ CCA-Cold Cranking Amps

C/K PICKUP—2-Wheel Drive

DIESEL

C20/2500 REGULAR CABS

C20/2500 BONUS CABS & CREW CABS

STANDARD SPECIFICATIONS

See Gray Tab Section for Specification Details)

Series	C20/2500 Regular Cab	C20/2500/C6P Regular Cab	C20/2500 Bonus/Crew Cab
Engine Base Equip. Clutch Air Filter Oil Filter Oil Cooler Exhaust System Emission Control Systems	6.2 Liter, 379 Cu. In V8 Diesel 12"; 150 sq. in. Poly-wrapped, Oiled-paper Element Throwaway Type Standard Dual; Aluminized See Engine & Cooling Section for specific model applications		
Suspension, Front Capacity Springs @ Ground Shock Absorbers Stabilizer Bar	Independent; Coil Springs 3800 lb.		
	1750 lb. ea. 25mm dia. —		1900 lb. ea. 32mm dia. 1.06" dia.
Suspension, Rear Axle Capacity Axle Ratio Springs, Main @ Ground Shock Absorbers	Salisbury Axle; Hypoid Drive; Two-stage Multi-leaf Springs		
	5700 lb. 3.42 2000 lb. ea. 25mm dia.	6000 lb. 3.42 3000 lb. ea. 32mm dia.	7500 lb. 3.73 3000 lb. ea. 32mm dia.
Brakes Front Rear Booster Parking	Hydraulic; Self-adjusting Disc; 12.5" Rotor		
	Drum; 11.15" x 2.75"		Drum; 13" x 2.5"
	Hydraulic Power Cable to Rear Wheels		
Electrical Battery—Freedom Type —Reserve Capacity Delcotron Generator Engine Block Heater	12 Volt; Negative Ground Two: 550 CCA ♦ ea. @ 0°F. 115 min. ea. @ 80°F. 66 amp. 600 watts, 120 volts		
Frame Section Modulus	Carbon Steel; 36,-39,000 psi		
	3.57	4.53	7.33
Fuel Tank (nominal capacity)	20 gal.		
Steering Gear Type	Integral Power		
Transmission	4-Speed Manual		
Shift Location	Floor		
Tires	(4) LT 215/85R16C (6PR)	Front: LT 235/85R16D (8PR) Rear: LT 235/85R16E (10PR)	
Wheels Size	(4) Disc 16" x 6.5"		

♦CCA-Cold Cranking Amps

GASOLINE

C/K PICKUP—2-Wheel Drive

C30/3500 BONUS CABS & CREW CABS—C30/3500 REGULAR CABS

STANDARD SPECIFICATIONS

(See Gray Tab Section for Specification Details)

Series	C30/3500 Regular Cab	C30/3500 Bonus/Crew Cab
Engine	4.8 Liter, 292 1-bbl L6	
Base Equip.	11"; 124 sq. in.	
Clutch	Oiled-paper Element	
Air Filter	Throwaway type	
Oil Filter	Single; Aluminized	
Exhaust System	See Engine & Cooling Section for specific model applications	
Emission Control Systems		
Suspension, Front	Independent; Coil Springs	
Capacity	3800 lb.	4000 lb.
Springs @ Ground	1900 lb. ea.	2000 lb. ea.
Shock Absorbers	32mm	
Suspension, Rear	Salisbury Axle; Hypoid Drive; Two-stage Multi-leaf Springs	
Axle Capacity	7500 lb.	
Axle Ratio	4.10	
Springs @ Ground	3500 lb. ea.	
Shock Absorbers	32mm dia.	
Brakes	Hydraulic, Self-adjusting	
Front	Disc; 12.5" rotor	
Rear	Drum; 13" x 3.5"	
Booster	Hydraulic Power	
Parking	Cable to Rear Wheels	
Electrical	12 Volt; Negative Ground	
Battery—Freedom Type	405 CCA♦ @ 0°F.	
—Reserve Capacity	75 min. @ 80°F.	
Delcotron Generator	37 amp.	
Frame	Carbon Steel; 36,-39,000 psi	
Section Modulus	6.14	7.33
Fuel Tank	20 gal.	
(Nominal Capacity)		
Steering Gear Type	Manual; Recirculating Ball Gear	
Linkage	Parallelogram	
Transmission	4-Speed Manual	
Shift Location	Floor	
Tires—Front	(2) LT235/85R16D (8PR)	
—Rear	(2) LT235/85R16E (10PR)	
Wheels	(4) Disc	
Size	16" x 6.5"	

♦CCA-Cold Cranking Amps

C/K PICKUP—2-Wheel Drive

DIESEL

C30/3500 BONUS CABS & CREW CABS—C30/3500 REGULAR CABS

STANDARD SPECIFICATIONS

(See Gray Tab Section for Specification Details)

Series	C30/3500 Regular Cab	C30/3500 Bonus/Crew Cab
Engine	6.2 Liter, 379 Cu. In. V8 Diesel	
Base Equip.	12"; 150 sq. in.	
Clutch	Poly-wrapped, Oiled-paper Element	
Air Filter	Throwaway type	
Oil Filter	Standard	
Oil Cooler	Dual; Aluminized	
Exhaust System	See Engine & Cooling Section for specific model applications	
Emission Control Systems		
Suspension, Front	Independent; Coil Springs	
Capacity	3800 lb.	4000 lb.
Springs @ Ground	1900 lb. ea.	2000 lb. ea.
Shock Absorbers	32mm	
Suspension, Rear	Salisbury Axle; Hypoid Drive; Two-stage Multi-leaf Springs	
Axle Capacity	7500 lb.	
Axle Ratio	4.10	
Springs @ Ground	3500 lb. ea.	
Shock Absorbers	32mm dia.	
Brakes	Hydraulic, Self-adjusting	
Front	Disc; 12.5" rotor	
Rear	Drum; 13" x 3.5"	
Booster	Hydraulic Power	
Parking	Cable to Rear Wheels	
Electrical	12 Volt; Negative Ground	
Battery—Freedom Type	Two; 550 CCA♦ ea. @ 0°F.	
—Reserve Capacity	115 min. ea. @ 80°F.	
Delcotron Generator	66 amp.	
Engine Oil Cooler	600 watts, 120 volts	
Frame	Carbon Steel; 36,-39,000 psi	
Section Modulus	6.14	7.33
Fuel Tank	20 gal.	
(Nominal Capacity)		
Steering Gear Type	Integral Power	
Transmission	4-Speed Manual	
Shift Location	Floor	
Tires—Front	(2) LT235/85R16D (8PR)	
—Rear	(2) LT235/85R16E (10PR)	
Wheels	(4) Disc	
Size	16" x 6.5"	

♦CCA-Cold Cranking Amps

GASOLINE

C/K PICKUP—4-Wheel Drive

K10/1500-20/2500 REGULAR CABS

STANDARD SPECIFICATIONS

(See Gray Tab Section for Specification Details)

Series	K10/1500	K20/2500	K20/2500/C6P
Engine Base Equip.	4.1 Liter, 250 2-bbl L6 ■ 11"; 124 sq. in.	5.7 Liter, 350 4-bbl V8 ■ 12"; 150 sq. in.	4.8 Liter, 292 1-bbl L6 11"; 124 sq. in.
Clutch	Oiled-paper Element Throwaway type Single; Aluminized		
Air Filter	See Engine & Cooling Section for specific model applications		
Oil Filter			
Exhaust System			
Emission Control System			
Suspension, Front	Salisbury Axle; Hypoid Drive; Single Stage Leaf Springs		
Capacity	3600 lb.	3800 lb.	3800 lb.
Axle Ratio	3.42	3.23	4.10
Springs @ Ground	1850 lb. ea.	1850 lb. ea.	1850 lb. ea.
Shock Absorbers	25mm dia.	25mm dia.	32mm dia.
Stabilizer Bar	1.25" dia. Standard		
Hubs, Automatic Locking			
Suspension, Rear	Salisbury Axle; Hypoid Drive; Two-stage Multi-leaf Springs		
Axle Capacity	3750 lb.	5700 lb.	6000 lb.
Axle Ratio	3.42	3.23	4.10
Springs @ Ground	1875 lb. ea.	2000 lb. ea.	3000 lb. ea.
Shock Absorbers	25mm dia.	25mm dia.	32mm dia.
Brakes	Hydraulic—Self-adjusting		
Front	Disc; 11.86" Rotor	Disc; 12.5" Rotor	Disc; 12.5" Rotor
Rear	Drum; 11.15" x 2.75"	Drum; 11.15" x 2.75"	Drum; 13.0" x 2.5"
Booster	Dual Diaphragm		
Parking	Cable to Rear Wheels		
Electrical	12 Volt; Negative Ground		
Battery—Freedom Type	405 CCA ♦ @ 0°F.		
—Reserve Capacity	75 min. @ 80°F.		
Delcotron Generator	37 amp.		
Frame	Carbon Steel; 36,-39,000 psi		
Section Modulus—117.5" WB	3.14	—	—
—131.5" WB	3.88	3.88	4.53
Fuel Tank (nominal capacity)	16 gal.	—	—
—117.5" WB	20 gal.	20 gal.	20 gal.
—131.5" WB			
Steering Gear Type	Integral Power		
Transmission	4-Speed Manual w/OD	4-Speed Manual	
Shift Location	Floor	Floor	
Transfer Case	New Process 208 2-Speed Conventional		
Shift Lever	Single Lever		
Tires	(5) P235/75R15	(4) LT215/85R16C (6PR)	Fr. (2) LT235/85R16D (8PR) Rr. (2) LT235/85R16E (10PR)
Wheels	(5) Disc 15" x 6"	(4) Disc 16" x 6.5"	(4) Disc 16" x 6.5"

■ Standard engine not available for registration in the State of California; see Power Teams Chart.

♦ CCA—Cold Cranking Amps

C/K PICKUP—4-Wheel Drive

DIESEL

K10/1500-20/2500 REGULAR CABS

STANDARD SPECIFICATIONS

(See Gray Tab Section for Specification Details)

Series	K10/1500	K20/2500	K20/2500/C6P
Engine	6.2 Liter, 379 Cu. In. V8 Diesel		
Base Equip.	12"; 150 sq. in.		
Clutch	Poly-wrapped Oiled-paper Element		
Air Filter	Throwaway type		
Oil Filter	Standard		
Oil Cooler	Dual; Aluminized		
Exhaust System	See Engine & Cooling Section for specific model applications		
Emission Control System	See Engine & Cooling Section for specific model applications		
Suspension, Front	Salisbury Axle; Hypoid Drive; Single Stage Leaf Springs		
Capacity	3600 lb.	3800 lb.	3800 lb.
Axle Ratio	3.08	3.73	3.73
Springs @ Ground	1850 lb. ea.	1850 lb. ea.	1850 lb. ea.
Shock Absorbers	25mm dia.	25mm dia.	32mm dia.
Stabilizer Bar	1.25" dia.		
Hubs, Automatic Locking	Standard		
Suspension, Rear	Salisbury Axle; Hypoid Drive; Two-stage Multi-leaf Springs		
Axle Capacity	3750 lb.	5700 lb.	6000 lb.
Axle Ratio	3.08	3.73	3.73
Springs @ Ground	1875 lb. ea.	2000 lb. ea.	3000 lb. ea.
Shock Absorbers	25mm dia.	25mm dia.	32mm dia.
Brakes	Hydraulic—Self-adjusting		
Front	Disc; 11.86" Rotor	Disc; 12.5" Rotor	Disc; 12.5" Rotor
Rear	Drum; 11.15" x 2.75"	Drum; 11.15" x 2.75"	Drum; 13.0" x 2.5"
Booster	Hydraulic Power		
Parking	Cable to Rear Wheels		
Electrical	12 Volt; Negative Ground		
Battery—Freedom Type	Two; 550 CCA♦ ea. @ 0°F.		
—Reserve Capacity	115 min. ea. @ 80°F.		
Delcotron Generator	66 amp.		
Engine Block Heater	600 watts, 120 volts		
Frame	Carbon Steel; 36,-39,000 psi		
Section Modulus—117.5" WB	3.14	—	—
—131.5" WB	3.88	3.88	4.53
Fuel Tank (nominal capacity)	—		
—117.5" WB	16 gal.	—	—
—131.5" WB	20 gal.	20 gal.	20 gal.
Overring Gear Type	Integral Power		
Transmission	4-Sp. Man. w/OD	4-Speed Manual	
Shift Location	Floor	Floor	
Transfer Case	New Process 208 2-Speed Conventional		
Shift Lever	Single Lever		
Tires	(5) P235/75R15	(4) LT215/85R16C (6PR)	Fr. (2) LT235/85R16D (8PR) Rr. (2) LT235/85R16E (10PR)
Wheels	(5) Disc 15" x 6"	(4) Disc 16" x 6.5"	(4) Disc 16" x 6.5"

♦ CCA—Cold Cranking Amps

GASOLINE

C/K PICKUP—4-Wheel Drive

**K30/3500 REGULAR CABS AND
K30/3500 BONUS CAB & CREW CABS**

STANDARD SPECIFICATIONS

(See Gray Tab Section for Specification Details)

Series	K30/3500 Regular Cab	K30/3500 Bonus/Crew Cab
Engine	4.8 Liter, 292 1-bbl. L6	
Base Equip.	11"; 124 sq. in.	
Clutch	Oiled-paper Element	
Air Filter	Throwaway Type	
Oil Filter	Single; Aluminized	
Exhaust System	See Engine & Cooling Section for specific model applications	
Emission Control Systems		
Suspension, Front	Salisbury Axle; Hypoid Drive; Single Stage Leaf Springs	
Capacity	4500 lb.	
Axle Ratio	4.56	
Springs @ Ground	2250 lb. ea.	
Shock Absorbers	32mm dia.	
Stabilizer Bar	1.25" dia.	
Hubs, Automatic Locking	Standard	
Suspension, Rear	Salisbury Axle; Hypoid Drive; Two-stage Multi-leaf Springs	
Axle Capacity	7500 lb.	
Axle Ratio	4.56	
Springs @ Ground	3500 lb. ea.	
Shock Absorbers	32mm dia.	
Brakes	Hydraulic; Self-adjusting	
Front	Disc; 12.5" Rotor	
Rear	Drum; 13.0" x 3.5"	
Booster	Hydraulic Power	
Parking	Cable to Rear Wheels	
Electrical	12 Volt; Negative Ground	
Battery—Frontron Type	405 CCA♦ @ 0°F.	
—Reserve Capacity	75 min. @ 80°F.	
Delcotron Generator	37 amp.	
Frame	Carbon Steel; 36-39,000 psi	
Section Modulus	6.14	7.33
Fuel Tank (nominal capacity)	20 gal.	
Steering Gear	Integral Power	
Transmission	4-Speed Manual	
Shift Location	Floor	
Transfer Case	New Process 205 2-Speed Conventional	
Shift Lever	Single Lever	
PTO Opening	Left Side	
Tires—Front	(2) LT235/85R16D (8PR)	
—Rear	(2) LT235/85R16E (10PR)	
Wheels	(4) Disc 16" x 6.5"	

♦CCA-Cold Cranking Amps

C/K PICKUP—4-Wheel Drive

DIESEL

K30/3500 REGULAR CABS AND K30/3500 BONUS CAB & CREW CABS

STANDARD SPECIFICATIONS

See Gray Tab Section for Specification Details)

Series	K30/3500 Regular Cab	K30/3500 Bonus/Crew Cab
Engine Base Equipment Clutch Air Filter Oil Filter Oil Cooler Exhaust System Emission Control System	6.2 Liter, 379 Cu. In. V8 Diesel 12"; 150 sq. in. Poly-wrapped, Oiled-paper Element Throwaway Type Standard Dual; Aluminized See Engine & Cooling Section for specific model applications	
Suspension, Front Capacity Axle Ratio Springs @ Standard Shock Absorbers Stabilizer Hubs, Automatic Locking	Salisbury Axle; Hypoid Drive; Single Stage Leaf Springs 4500 lb. 4.10 2250 lb. ea. 32mm dia. 1.25" dia. Standard	
Suspension, Rear Axle Capacity Axle Ratio Springs @ Standard Shock Absorbers	Salisbury Axle; Hypoid Drive; Two-stage Multi-leaf Springs 7500 lb. 4.10 3500 lb. ea. 32mm dia.	
Brakes Front Rear Booster Parking	Hydraulic; Self-adjusting Disc; 12.5" Rotor Drum; 13.0" x 3.5" Hydraulic Power Cable to Rear Wheels	
Electrical Battery—Standard Type Reserve Capacity Delcotron Alternator Engine Block Heater	12 Volt; Negative Ground Two; 550 CCA ♦ ea. @ 0°F. 115 min. ea. @ 80°F. 66 amp. 600 watts, 120 volts	
Frame Section Modulus	Carbon Steel; 36,39,000 psi 6.14 7.33	
Fuel Tank (standard capacity)	20 gal.	
Steering Gear Type	Integral Power	
Transmission Shift Location	4-Speed Manual Floor	
Transfer Case Shift Lever PTO Opening	New Process 205 2-Speed Conventional Single Lever Left Side	
Tires—Front —Rear	(2) LT235/85R16D (8PR) (2) LT235/85R16E (10PR)	
Wheels	(4) Disc 16" x 6.5"	

♦ CCA—Cold Cranking Amps

GASOLINE

C/K PICKUP

C10/1500-30/3500 SERIES FLEETSIDE/WIDESIDE PICKUP

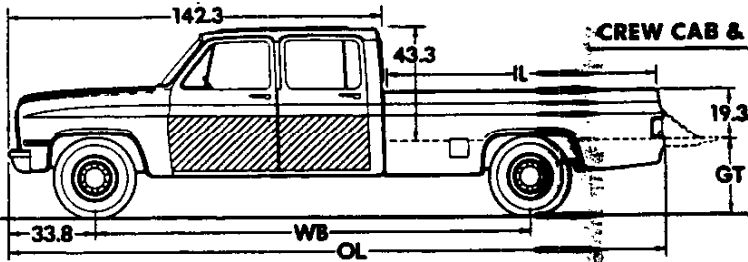

CREW CAB & BONUS CAB

Body Ordering Codes:
 Regular Cab—E63
 Bonus Cab—E63 & YG4
 Crew Cab—E63 & AS3

Sign Panel Area (side)
 Regular Cab—22" x 39½"
 Bonus/Crew Cab—22" x 72¼"



REGULAR CAB

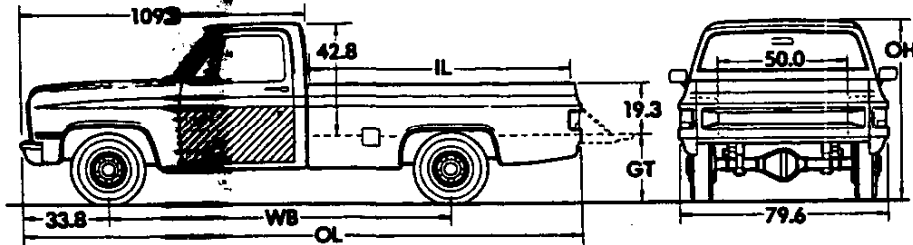

Model	Wheelbase (in)	Body—Rear End Weight Distribution*	
		% Front	% Rear
C1	117.5	1	99
C1-3	131.5	4	96
C2-3	164.5	3	97

Series	Ground Clearance (in)*	
	Front	Rear
C1	7.6	7.3
C2	8.0	7.8
C3	8.0	7.7

*Estimate based on water-level loading.

Model	Engine No. Cyl.	Dimensions (in)*					Curb Weight (lb)			Model Weight (lb)*		
		WB	IL	OL	CH	GT	Front	Rear	Total	Front	Rear	Total

C10/1500 SERIES

C10703	6	117.5	78.2	191.9	69.8	28.0	2067	1419	3486	2287	1649	3936
C10903	6	131.5	98.1	211.8	69.8	28.0	2147	1501	3648	2393	1705	4098

C20/2500 SERIES

C20903	6	131.5	98.1	211.8	71.6	30.6	2353	1695	4048	2599	1899	4498
C20903 (w/C6P)	6	131.5	98.1	211.8	71.6	30.6	2384	1762	4146	2630	1966	4596
C20943 (Bonus Cab)	6	164.5	98.1	244.8	73.8	31.7	2677	2070	4747	2962	2235	5197
C20943 (Crew Cab)	6	164.5	98.1	244.8	73.8	31.7	2704	2104	4808	3184	2524	5708

C30/3500 SERIES

C30903	6	131.5	98.1	211.8	73.0	32.9	2496	1913	4409	2742	2117	4859
C30943 (Bonus Cab)	6	164.5	98.1	244.8	73.5	32.3	2738	2091	4829	3023	2256	5279
C30943 (Crew Cab)	6	164.5	98.1	244.8	73.5	32.3	2765	2125	4890	3245	2545	5790

*Dimensions with standard equipment, unloaded. *Model Weight includes Curb Weight plus occupants (standard seating capacity x 150 lb.). Total Model Weight may vary as much as ±50 lbs. to allow for production build variation.

C/K PICKUP

C10/1500 C30/3500 SERIES FLEETSIDE/WIDESIDE PICKUP

DIESEL

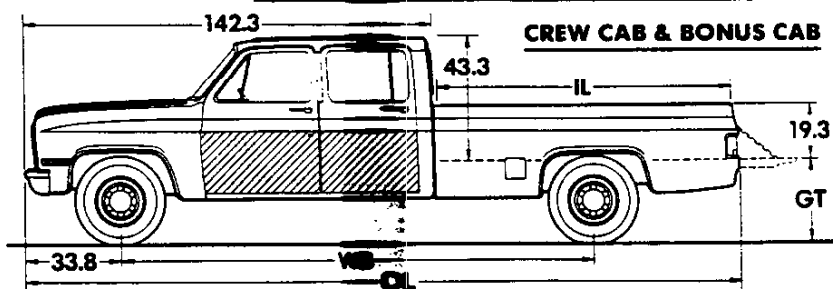

Body Ordering Codes:
 Regular Cab—E63/B3J
 Bonus Cab—E63/YG4/B3J
 Crew Cab—E63/AS3/B3J

Sign Panel Area (side)
 Regular Cab—22" x 39 1/4"
 Bonus/Crew Cab—22" x 72 1/4"

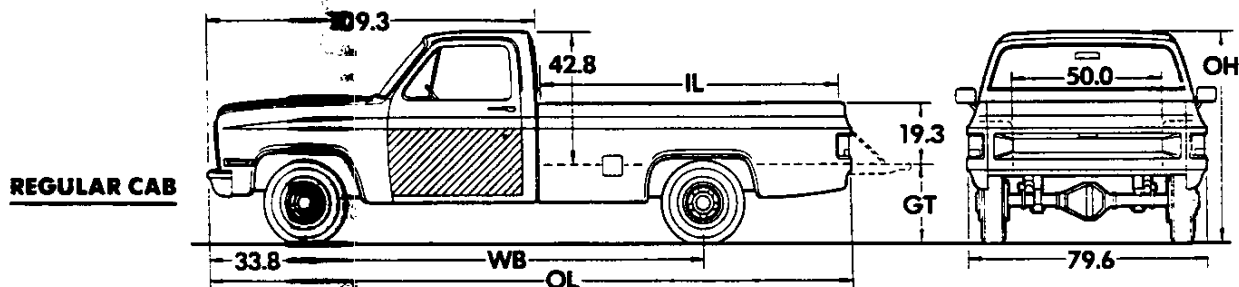

Model	Wheelbase (in)	Body—Payload Weight Distribution*	
		% Front	% Rear
C1	117.5	1	99
C1-3	131.5	4	96
C2-3	164.5	3	97

Series	Ground Clearance (in)*	
	Front	Rear
C1	7.6	7.3
C2	8.0	7.8
C3	8.0	7.7

*Estimate based on water-level loading.

Model	Engine No. Cyl.	Dimensions (in)*					Curb Weight (lb)			Model Weight (lb)*		
		WB	XL	OL	OH	GT	Front	Rear	Total	Front	Rear	Total

C10/1500 SERIES

C10703	8	117.5	78.2	191.9	69.8	28.0	2562	1483	4045	2782	1713	4495
C10903	8	131.5	98.1	211.8	69.8	28.0	2644	1564	4208	2890	1768	4658

C20/2500 SERIES

C20903	8	131.5	98.1	211.8	71.6	30.6	2738	1731	4469	2984	1935	4919
C20903 (w/C6P)	8	131.5	98.1	211.8	71.6	30.6	2875	1877	4752	3121	2081	5202
C20943 (Bonus Cab)	8	164.5	98.1	244.8	73.8	31.7	3110	2134	5244	3395	2299	5694
C20943 (Crew Cab)	8	164.5	98.1	244.8	73.8	31.7	3137	2168	5305	3617	2588	6205

C30/3500 SERIES

C30903	8	131.5	98.1	211.8	73.0	32.9	2906	1966	4872	3152	2170	5322
C30943 (Bonus Cab)	8	164.5	98.1	244.8	73.5	32.3	3151	2155	5306	3436	2320	5756
C30943 (Crew Cab)	8	164.5	98.1	244.8	73.5	32.3	3178	2189	5367	3658	2609	6267

*Dimensions with standard equipment, unloaded. *Model Weight includes Curb Weight plus occupants (standard seating capacity x 150 lb.). Total Model Weight may vary as much as ±50 lbs. to allow for production build variation.

GASOLINE

C/K PICKUP

K10/1500-30/3500 SERIES FLEETSIDE/WIDESIDE PICKUP

Body Ordering Codes:

Regular Cab—E63

Bonus Cab—E63 & YG4

Crew Cab—E63 & AS3

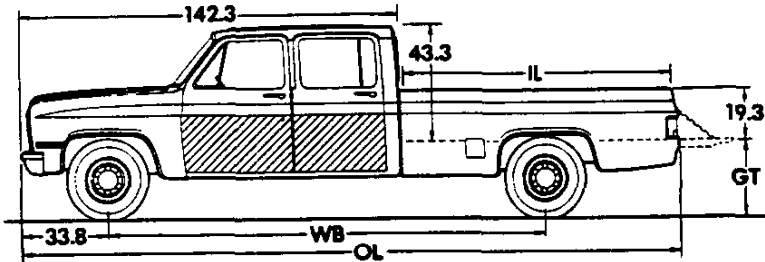

BONUS CAB & CREW CAB

Sign Panel Area (side)
 Regular Cab—22" x 39¼"
 Bonus/Crew Cab—22" x 72¼"

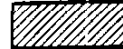

REGULAR CAB

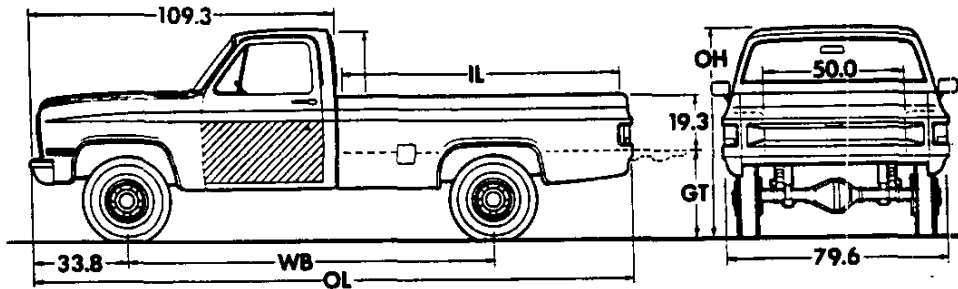

Model	Wheelbase (in)	Body - Payload Weight Distribution*	
		% Front	% Rear
K1	117.5	1	99
K1-3	131.5	4	96
K3	164.5	3	97

Series	Ground Clearance (in)*	
	Front	Rear
K1	7.4	7.1
K2	8.8	7.2
K3	8.3	7.8

*Estimate based on water-level loading.

Model	Engine No. Cyl.	Dimensions (in)*					Curb Weight (lb)			Model Weight (lb)*		
		WB	IL	OL	OH	GT	Front	Rear	Total	Front	Rear	Total

K10/1500 SERIES

K10703	6	117.5	78.2	192.6	73.0	31.2	2459	1589	4048	2679	1819	4498
K10903	6	131.5	98.1	212.5	73.0	31.2	2554	1688	4242	2800	1892	4692

K20/2500 SERIES

K20903	8	131.5	98.1	212.5	73.6	32.7	2743	1746	4489	2989	1950	4939
K20903 (w/C6P)	6	131.5	98.1	212.5	73.6	32.7	2751	1827	4578	2997	2031	5028

K30/3500 SERIES

K30903	6	131.5	98.1	212.5	75.8	34.9	2905	1987	4892	3151	2191	5342
K30943 (Bonus Cab)	6	164.5	98.1	244.8	76.2	34.6	3147	2161	5308	3432	2326	5758
K30943 (Crew Cab)	6	164.5	98.1	244.8	76.2	34.6	3174	2195	5369	3654	2615	6269

*Dimensions with standard equipment, unloaded. *Model Weight includes Curb Weight plus occupants (standard seating capacity x 150 lb). Total Model Weight may vary as much as ±50 lbs. to allow for production build variation.

C/K PICKUP

K10/1500-30/3500 SERIES FLEETSIDE/WIDESIDE PICKUP

DIESEL

Body Ordering Codes:
 Regular Cab—E63/B3J
 Bonus Cab—E63/YG4/B3J
 Crew Cab—E63/AS3/B3J

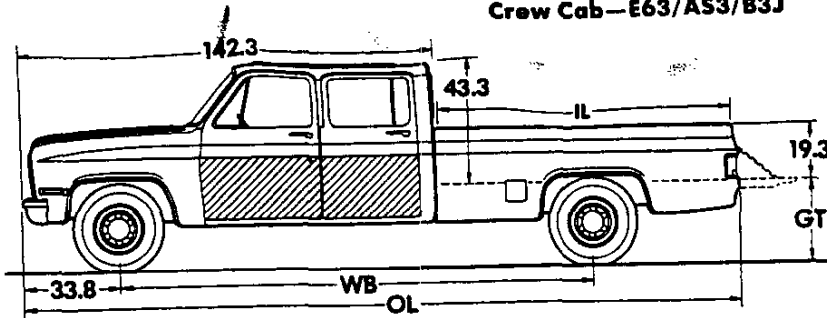

BONUS CAB & CREW CAB

Sign Panel Area (side)
 Regular Cab—22" x 39 1/4"
 Bonus/Crew Cab—22" x 72 1/4"



REGULAR CAB

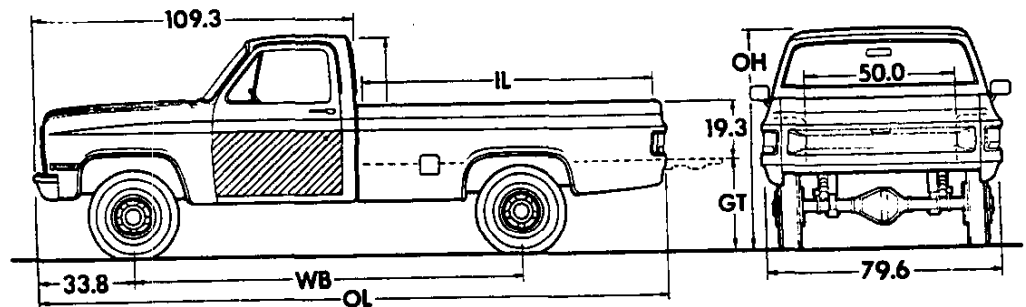

Model	Wheelbase (in)	Body—Payload Weight Distribution*	
		% Front	% Rear
K1	117.5	1	99
K1-3	131.5	4	96
K3	164.5	3	97

Series	Ground Clearance (in)*	
	Front	Rear
K1	7.4	7.1
K2	8.8	7.2
K3	8.3	7.8

*Estimate based on water-level loading.

Model	Engine No. Cyl.	Dimensions (in)*					Curb Weight (lb)			Model Weight (lb)*		
		WB	IL	OL	OH	GT	Front	Rear	Total	Front	Rear	Total

K10/1500 SERIES

K10703	8	117.5	78.2	192.6	73.0	31.2	2868	1634	4502	3088	1864	4952
K10903	8	131.5	98.1	212.5	73.0	31.2	2963	1733	4696	3209	1937	5146

K20/2500 SERIES

K20903	8	131.5	98.1	212.5	73.6	32.7	3051	1782	4833	3297	1986	5283
K20903 (w/C6P)	8	131.5	98.1	212.5	73.6	32.7	3110	1915	5025	3356	2119	5475

K30/3500 SERIES

K30903	8	131.5	98.1	212.5	75.8	34.9	3307	2040	5347	3553	2244	5797
K30943 (Bonus Cab)	8	164.5	98.1	244.8	76.2	34.6	3548	2225	5773	3833	2390	6223
K30943 (Crew Cab)	8	164.5	98.1	244.8	76.2	34.6	3575	2259	5834	4055	2679	6734

*Dimensions with standard equipment, unloaded. *Model Weight includes Curb Weight plus occupants (standard seating capacity x 150 lb). Total Model Weight may vary as much as ±50 lbs. to allow for production build variation.

GASOLINE

C/K PICKUP

STEPSIDE/FENDERSIDE PICKUP

Body Ordering Code—E62

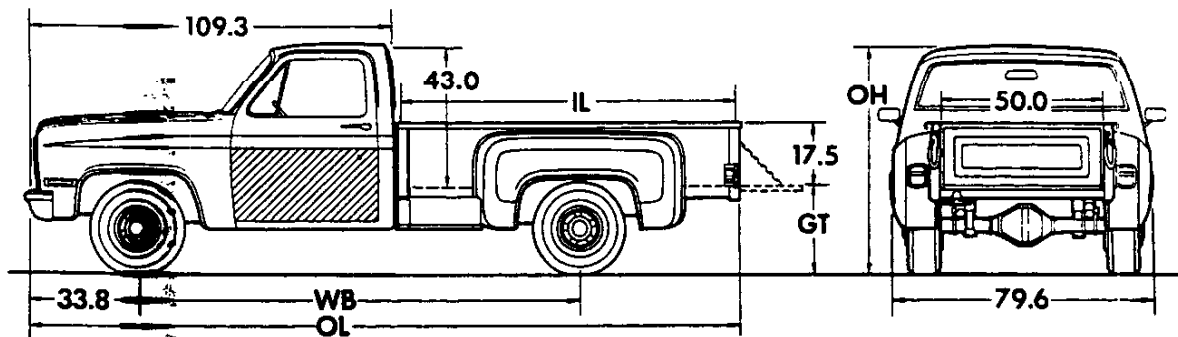

Sign Panel Area (22" x 39 1/4")



Model	Wheelbase (in.)	Body—Payload Weight Distribution*	
		% Front	% Rear
C-K1	117.5	1	99
C-K1-2-3	131.5	4	96

*Estimate based on water-level loading.

Series	Ground Clearance (in.)*	
	Front	Rear
C1	7.5	7.2
C2	8.0	7.8
C3	8.0	7.8
K1	7.2	7.1
K2	8.8	7.2

Model	Engine No. Cyl.	Dimensions (in.)*					Curb Weight (lb)			Model Weight (lb)*		
		WB	IL	OL	OH	GT	Front	Rear	Total	Front	Rear	Total

C10/1500 SERIES

C10703	5	117.5	78.4	191.1	69.9	28.0	2065	1374	3439	2285	1604	3889
---------------	----------	-------	------	-------	------	------	------	------	------	------	------	------

C20/2500 SERIES

C20903	6	131.5	98.3	211.0	71.6	30.6	2348	1638	3986	2594	1842	4436
C20903 (W/C6P)	6	131.5	98.3	211.0	71.6	30.6	2379	1705	4084	2625	1909	4534

C30/3500 SERIES

C30903	6	131.5	98.3	211.0	73.0	32.7	2491	1856	4347	2737	2060	4797
---------------	----------	-------	------	-------	------	------	------	------	------	------	------	------

K10/1500 SERIES

K10703	5	117.5	78.4	191.7	73.0	31.1	2457	1544	4001	2677	1774	4451
---------------	----------	-------	------	-------	------	------	------	------	------	------	------	------

K20/2500 SERIES

K20903	8	131.5	98.3	211.6	73.7	32.6	2738	1689	4427	2984	1893	4877
K20903 (W/C6P)	6	131.5	98.3	211.6	73.7	32.6	2746	1770	4516	2992	1974	4966

*Dimensions with standard equipment, unloaded. *Model Weight includes Curb Weight plus occupants (standard seating capacity x 150 lb.). Total Model Weight may vary as much as ± 50 lbs. to allow for production build variation.

C/K PICKUP

STEPSIDE/FENDERSIDE PICKUP

Body Ordering Code—E62/B3J

DIESEL

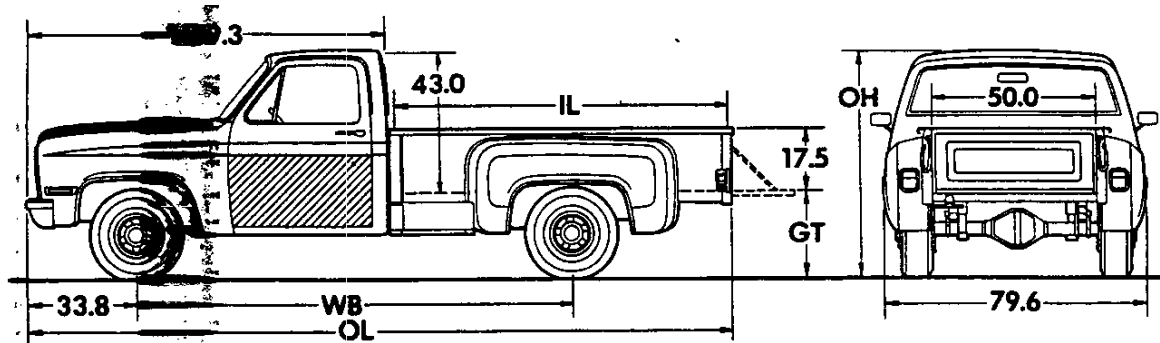

Sign Panel Area (22" x 39 1/2")

Model	Wheelbase (in.)	Body-Payload Weight Distribution*	
		% Front	% Rear
C-K1	117.5	1	99
CK1-2-3	131.5	4	96

*Estimate based on level loading.

Series	Ground Clearance (in.)*	
	Front	Rear
C1	7.5	7.2
C2	8.0	7.8
C3	8.0	7.8
K1	7.2	7.1
K2	8.8	7.2

Model	Engine No.	Dimensions (in.)*					Curb Weight (lb)			Model Weight (lb)*		
		WB	IL	OL	OH	GT	Front	Rear	Total	Front	Rear	Total

C10/1500 SERIES

C10703	B	117.5	78.4	191.1	69.9	28.0	2560	1439	3999	2780	1669	4449
---------------	----------	-------	------	-------	------	------	------	------	------	------	------	------

C20/2500 SERIES

C20903	B	131.5	98.3	211.0	71.6	30.6	2733	1674	4407	2979	1878	4857
C20903 (W/C6P)	B	131.5	98.3	211.0	71.6	30.6	2870	1820	4690	3116	2024	5140

C30/3500 SERIES

C30903	B	131.5	98.3	211.0	73.0	32.7	2901	1909	4810	3147	2113	5260
---------------	----------	-------	------	-------	------	------	------	------	------	------	------	------

K10/1500 SERIES

K10703	B	117.5	78.4	191.7	73.0	31.1	2866	1589	4455	3086	1819	4905
---------------	----------	-------	------	-------	------	------	------	------	------	------	------	------

K20/2500 SERIES

K20903	B	131.5	98.3	211.6	73.7	32.6	3046	1725	4771	3292	1929	5221
K20903 (W/C6P)	B	131.5	98.3	211.6	73.7	32.6	3105	1858	4963	3351	2062	5413

*Dimensions with standard equipment, unloaded. *Model Weight includes Curb Weight plus occupants (standard seating capacity x 150 lb.). Total Model Weight may vary as much as ± 50 lbs. to allow for production build variation.

C/K PICKUP
POWER TEAMS
ALL STATES EXCEPT CALIFORNIA
C100/1500 SERIES

POWER TEAMS (MUST ORDER ENGINE, TRANSMISSION AND REAR AXLE)
 (Consult GVWR Selector and Tire Capacity for capacity and availability)

ENGINE	TRANSMISSION			AXLES					GVWR	
	3-SP	4-SP	5-SP	#258	273	308	342	373		
W/NA5 STANDARD EMISSION EQUIPMENT										
-C10703-C10903										
LE3 L6 4.1 Liter (250-2BBL)	MND	4804	8K1	-	-	GQ1	*GU4	-	-	4900
		4807	MND	-	-	-	GQ1	*GU6	-	4900
	MND	4806	8K1	-	-	GQ1	*GU4	-	-	52/5600
		4807	MND	-	-	-	GQ1	*GU6	-	52/5600
	MND	4804	-	-	-	-	GQ1	-	-	6100
		4807	-	-	-	-	-	GQ1	-	6100
		4807	MND	-	-	-	GQ1	GU6	-	6100
LE9 V8 5.0 Liter (305-4BBL)	MND	4804/7	8K1	-	-	GQ1	GU4	-	-	4900
		4807	MND	-	-	GQ1	GU4	-	-	4900
	MND	4807	8K1	-	#GQ1	GU2	-	-	-	4900
		4807	MND	-	-	GQ1	GU4	-	-	52/5600
	MND	4807	8K1	-	#GQ1	GU2	-	-	-	52/5600
		4807	MND	-	-	-	GQ1	-	-	6100
		4807	8K1	-	#GQ1	GU2	-	-	-	6100
LH8 Diesel 6.2 Liter V8 (379 Cu. In.)(Reqs B3J)	4804/7	8K1	-	-	GQ1	GU4	-	-	52/5600	
	4804/7	MND	-	-	-	GQ1	GU6	-	6100	
-K10703-K10903										
LE3 L6 4.1 Liter (250-2 BBL)		4804/7	MND	-	-	-	GQ1	GT4	6100	
LE9 V8 5.0 Liter (305-4BBL)		4807	MND	-	-	-	GQ1	GT4	6100	
		4804	MND	-	-	GQ1	GU4	-	6100	
LH8 Diesel 6.2 Liter V8 (379 Cu. In.)(Reqs B3J)		4804/7	MND	-	-	-	GQ1	GU6	6100	
W/NA6 HIGH ALTITUDE EMISSION EQUIPMENT										
-C10703-C10903										
LE3 L6 4.1 Liter (250-2 BBL)	MND	4804/7	MND/3	-	-	-	GQ1	‡GT4	ALL	
LE9 V8 5.0 Liter(305-4BBL)	MND	4804/7	MND/3	-	-	-	GQ1	-	‡GT4	
LH8 Diesel 6.2 Liter V8 (379 Cu. In.)(Reqs B3J)		4804/7	MND	-	-	-	GQ1	GT4	52/5600	
		4804/7	MND	-	-	-	GQ1	GU6	GT4	
-K10703-K10903										
LE3 L6 4.1 Liter (250-2 BBL)		4804/7	MND	-	-	-	GQ1	GT4	6100	
LE9 V8 5.0 Liter (305-4BBL)		4807	MND	-	-	-	GQ1	GT4	6100	
		4804	MND	-	-	-	GQ1	GT4	6100	
LH8 Diesel 6.2 Liter V8 (379 Cu. In.)(Reqs B3J)		4804/7	MND	-	-	-	GQ1	GT4	6100	

*N/A P195/75R15 or P205/75R15 Tires
 #N/A G80 Locking Differential
 ‡N/A W/MX1 Trans

**C/K PICKUP
POWER TEAMS
CALIFORNIA ONLY
C-K10/1500 SERIES**

POWER TEAMS (MUST ORDER ENGINE, TRANSMISSION AND REAR AXLE)
(Consult GVWR Selector and Tire Chart to insure tire capacity and availability)

ENGINE	TRANSMISSION			AXLES					GVW	
	3-SP	4-SP	AUTO	#256	273	308	342	373		
W/YF5 CALIFORNIA EMISSION REQUIREMENTS										
-C10703-C10903										
LE3 L6 4.1 Liter (250-288L)	MM3					GQ1				49/5200
		MM7	MX0				GQ1			49/5200
	MM3						GQ1	GU4		5600
		MM7	MX0					GU6		5600
	MM3						GQ1			6100
LF3 V8 5.0 Liter(305-488L)			MM7					GQ1		6100
			MM7					GQ1	GU6	6100
			MX0				GQ1	GU6		6100
LH6 Diesel 6.2 Liter V8 (379 Cu. In.)(Reqs B3J)			MX0					GQ1	GU4	52/5600
			MX0					GQ1	GU6	6100
-K10703-K10903										
LS9 V8 5.7 Liter (350-4 BBL)			MX0					GQ1	GU4	6100
			MX0					GQ1	GU6	6100
LH6 Diesel 6.2 Liter V8 (379 Cu. In.)(Reqs B3J)			MX0					GQ1	GU6	6100
			MX0					GQ1	GU6	6100

#N/A G80 Locking Differential

ENGINE RATINGS

ALL STATES EXCEPT CALIFORNIA

SAE Net Ratings @ 85°F	*4.1 Liter 250 2-bbl L6	**4.8 Liter 292 1-bbl L6	*5.0 Liter 305 4-bbl V8
Net Horsepower	115 @ 3600 rpm	115 @ 3600 rpm	160 @ 4400 rpm
Net Torque, lb-ft	200 @ 2000 rpm	215 @ 1600 rpm	235 @ 2000 rpm
SAE Net Ratings @ 85°F	*5.7 Liter 350 4-bbl V8	**5.7 Liter 350 4-bbl V8	**7.4 Liter 454 4-bbl V8
Net Horsepower	165 @ 3800 rpm	160 @ 3800 rpm	230 @ 3800 rpm
Net Torque, lb-ft	275 @ 1600 rpm	250 @ 2800 rpm	360 @ 2800 rpm
SAE Net Ratings @ 85°F	*6.2 Liter 379 V8 Diesel	**6.2 Liter 379 V8 Diesel	
Net Horsepower	130 @ 3600 rpm	135 @ 3600 rpm	
Net Torque, lb-ft	240 @ 2000 rpm	240 @ 2000 rpm	

*Engine with Light or Medium Duty Emissions (w/GVWR up to 8500 lb.).

**Engine with Heavy Duty Emissions (w/GVWR over 8500 lb.).

ENGINE RATINGS

CALIFORNIA ONLY

SAE Net Ratings	*4.1 Liter 250 2-bbl L6	**4.8 Liter 292 1-bbl L6	*5.0 Liter 305 4-bbl V8	*5.7 Liter 350 4-bbl V8
Net Horsepower	110 @ 3600 rpm	115 @ 3600 rpm	155 @ 4000 rpm	165 @ 3800 rpm
Net Torque, lb-ft	200 @ 1600 rpm	215 @ 1600 rpm	245 @ 1600 rpm	275 @ 1600 rpm
SAE Net Ratings	**5.7 Liter 350 4-bbl V8	**7.4 Liter 454 4-bbl V8	*6.2 Liter 379 V8 Diesel	**6.2 Liter 379 V8 Diesel
Net Horsepower	155 @ 4000 rpm	230 @ 3800 rpm	130 @ 3600 rpm	135 @ 3600 rpm
Net Torque, lb-ft	240 @ 2800 rpm	360 @ 2800 rpm	240 @ 2000 rpm	240 @ 2000 rpm

*Engine with Light or Medium Duty Emissions (w/GVWR up to 8500 lb.).

**Engine with Heavy Duty Emissions (w/GVWR over 8500 lb.).

C/K PICKUP
POWER TEAMS
ALL STATES EXCEPT CALIFORNIA
C20/2500 SERIES

POWER TEAMS (MUST ORDER ENGINE, TRANSMISSION AND REAR AXLE)
 (Consult GVWR Selector and Tire Chart to insure tire capacity and availability)

ENGINE	TRANSMISSION		AXLES					GVWR	
	4-SP	AUTO	#3.23	3.42	3.73	4.10	4.56		
W/NA5 STANDARD EMISSION EQUIPMENT (LL4, L25, LT9 or LE8 Satisfies High Altitude Emission Requirements)									
-C20903									
LE3 L6 4.1 Liter (250-2 BBL) (N/A C6P)	MM4	MX0	—	—	GQ1	GT4	—	—	64/7200
	MM4	MX0	—	—	—	—	GQ1	—	8200
L25 L6 4.8 Liter (292-1BBL)(Reqs C6P)	MM4		—	—	—	—	GQ1	HC4	8600
LE9 V8 5.0 Liter (305-4BBL) (N/A C6P)	MM4		#GQ1	GU6	—	—	—	—	6400
		MX0	#GQ1	GU6	GT4	—	—	—	6400
	MM4		—	—	GQ1	—	—	—	7200
LT9 V8 5.7 Liter (350-4BBL)(Reqs C6P)		MX0	—	—	GQ1	GT4	—	—	7200
	MM4		—	—	GQ1	GT4	GT5	—	8600
		MX0	—	—	GQ1	GT5	HC4	—	8600
LE8 V8 7.4 Liter (454-4BBL) (Reqs C6P, N41&UA1)	MM4	MX1	#GQ1	—	—	—	GQ1	HC4	8600
		MX1	—	—	—	—	GQ1	HC4	8600
LH6 Diesel 6.2 Liter V8 (379 Cu. In.)(Reqs B3J) (N/A C6P)	MM4		—	—	GQ1	GT4	—	—	6400
		MX0	#GQ1	GU6	—	—	—	—	6400
	MM4		—	—	GQ1	GT5	—	—	7200
LL4 Diesel 6.2 Liter V8 (379 Cu. In.) (Reqs B3J & C6P)		MX0	—	—	GQ1	—	—	—	7200
	MM4		—	—	GQ1	GT5	—	—	8600
		MX1	—	—	GQ1	GT5	HC4	—	8600
		MX1	—	—	—	GQ1	HC4	—	8600
-K20903									
L25 L6 4.8 Liter (292-1BBL)(Reqs C6P)	MM4		—	—	—	—	GQ1	—	8600
LS9 V8 5.7 Liter (350-4BBL)(N/A C6P)	MM4		#GQ1	GU6	—	—	—	—	6600
		MX0	#GQ1	GU6	GT4	—	—	—	6600
LT9 V8 5.7 Liter (350-4BBL)(Reqs C6P)	MM4		—	—	GQ1	GT4	GT5	—	8600
		MX0	—	—	—	GQ1	GT5	—	8600
		MX1	—	—	—	—	GQ1	—	8600
LH6 Diesel 6.2 Liter V8 (379 Cu. In.)(Reqs B3J) (N/A C6P)	MM4		—	—	GQ1	GT5	—	—	6600
		MX0	—	—	GQ1	GT4	—	—	6600
LL4 Diesel 6.2 Liter V8 (379 Cu. In.) (Reqs B3J&C6P)	MM4	MX0	—	—	—	GQ1	GT5	—	8600
		MX1	—	—	—	—	GQ1	—	8600
-C20943									
L25 L6 4.8 Liter (292-1BBL)	MM4		—	—	—	—	GQ1	HC4	8600
LT9 V8 5.7 Liter (350-4BBL)	MM4		—	—	—	GQ1	GT5	—	8600
		MX1	—	—	—	—	GQ1	HC4	8600
LE8 V8 7.4 Liter (454-4BBL) (Reqs N41&UA1)	MM4	MX1	#GQ1	—	—	—	GQ1	HC4	8600
LL4 Diesel 6.2 Liter V8 (379 Cu. In.)(Reqs B3J)	MM4		—	—	—	GQ1	GT5	—	8600
		MX1	—	—	—	—	GQ1	HC4	8600

#N/A G80 Locking Differential;w/LE8 Eng Rear Axle is 3.21

C/K PICKUP

POWER TEAMS

ALL STATES EXCEPT CALIFORNIA

C-K20/2500 SERIES

ENGINE	TRANSMISSION		AXLES				GVW	
	4-SP	AUTO	#3.23	3.42	3.73	4.10		
W/86 HIGH ALTITUDE EMISSION EQUIPMENT								
-C8903								
LE3 4.1 Liter (2500 BBL) (N/A C6P)	MM4	MX0	—	—	GQ1	GT5	—	84/7200
	MM4	MX0	—	—	—	GQ1	—	8200
LE9 5.0 Liter (3050 BBL) (N/A C6P)	MM4	MX0	—	GQ1	GT4	—	—	84/7200
LH6 Diesel 6.2 Liter V8 (379 Cu In) (N/A C6P) (Reqs B3J)	MM4	MX0	—	GQ1	GT4	—	—	6400
	MM4		—	—	GQ1	GT5	—	7200
		MX0	—	GQ1	GT4	—	—	7200
LL4 Diesel 6.2 Liter V8 (379 Cu In) (Reqs B3J & C6P)	MM4		—	—	GQ1	GT5	—	8600
		MX0	—	—	GQ1	GT5	HC4	8600
		MX1	—	—	—	GQ1	HC4	8600
-K20903								
LS8 5.7 Liter (3500 BBL) (N/A C6P)	MM4		#GQ1	GU6	—	—	—	8600
		MX0	—	GQ1	GT4	—	—	6600
LH6 Diesel 6.2 Liter V8 (379 Cu. In.) (N/A C6P) (Reqs B3J)	MM4		—	—	GQ1	GT5	—	6600
		MX0	—	GQ1	GT4	—	—	6600
LL4 Diesel 6.2 Liter V8 (Reqs B3J & C6P)	MM4	MX0	—	—	GQ1	GT5	—	8600
		MX1	—	—	—	GQ1	—	8600
-C8943								
LL4 Diesel 6.2 Liter V8 (379 Cu. In.) (Req B3J)	MM4		—	—	GQ1	GT5	—	8600
		MX1	—	—	—	GQ1	HC4	8600

#N/A 80 Locking Differential; w/LE9 Eng Rear Axle is 3.2:1

■ High Altitude Emission Equipment (FOR EXHAUST SMOKE REDUCTION PURPOSES
 ■ HIGH ALTITUDE; NOT REQUIRED TO SATISFY HIGH ALTITUDE REGULATIONS) (REQS LL4 ENG)

**C/K PICKUP
POWER TEAMS
CALIFORNIA ONLY
C-K20/2500 SERIES**

POWER TEAMS (MUST ORDER ENGINE, TRANSMISSION AND REAR AXLE)
(Consult GVW Selector and Tire Chart to insure tire capacity and availability)

ENGINE	TRANSMISSION		AXLES					GVW
	4-SP	AUTO	#3.23	3.42	3.73	4.10	4.56	
W/YF5 California Emission Requirements								
-C20903								
L25 L6 4.8 Liter (292-1BBL)(Reqs C6P)	MM4		-	-	-	GQ1	HC4	8600
LS9 V8 5.7 Liter (350-4BBL)(N/A C6P)		MX0	#GQ1	GU6	-	-	-	64/7200
LT9 V8 5.7 Liter (350-4BBL)(Reqs C6P)	MM4		-	GQ1	GT4	GT5	-	8600
		MX0	-	-	GQ1	GT5	HC4	8600
		MX1	-	-	-	GQ1	HC4	8600
LE8 V8 7.4 Liter (454-4BBL) (Reqs C6P, N41 & UA1)	MM4	MX1	#GQ1	-	GT4	GT5	-	8600
			-	GU6	-	-	-	6400
LH6 Diesel 6.2 Liter V8 (379 Cu In)(Reqs B3J)		MX0	#GQ1	GU6	-	-	-	7200
		MX0	-	GQ1	-	-	-	8600
LL4 Diesel 6.2 Liter V8 (379 Cu In)(Reqs B3J & C6P)	MM4		-	-	GQ1	GT5	-	8600
		MX0	-	-	GQ1	GT5	HC4	8600
		MX1	-	-	-	GQ1	HC4	8600
-K20903								
L25 L6 4.8 Liter (292-1BBL)(Reqs C6P)	MM4		-	-	-	GQ1	-	8600
LT9 V8 5.7 Liter (350-4BBL)(Reqs C6P)	MM4		-	GQ1	GT4	GT5	-	8600
		MX0	-	-	GQ1	GT5	-	8800
		MX1	-	-	-	GQ1	-	8600
LL4 Diesel 6.2 Liter V8 (379 Cu In)(Reqs B3J & C6P)	MM4	MX0	-	-	GQ1	GT5	-	8600
		MX1	-	-	-	GQ1	-	8600
-C20943								
L25 L6 4.8 Liter (292-1 BBL)	MM4		-	-	-	GQ1	HC4	8600
LT9 V8 5.7 Liter (350-4BBL)	MM4		-	-	GQ1	GT5	-	8600
		MX1	-	-	-	GQ1	HC4	8600
LE8 V8 7.4 Liter (454-4BBL) (Reqs N41 & UA1)	MM4	MX1	#GQ1	-	GT4	GT5	-	8600
LL4 Diesel 6.2 Liter V8 (379 Cu In)(Reqs B3J)	MM4		-	-	GQ1	GT5	-	8600
		MX1	-	-	-	GQ1	HC4	8600

#N/A G80 Locking Differential; w/LE8 Eng Rear Axle is 3.21

C/K PICKUP

POWER TEAMS

ALL STATES

C-K30/3500 SERIES

POWER TEAMS (MUST ORDER ENGINE, TRANSMISSION AND REAR AXLE)
 (Consult GVWR Selection and Tire Chart to insure tire capacity and availability)

W/NA5 STANDARD (Satisfies High Altitude Emission Requirements), NA6 HIGH ALTITUDE OR YF5 CALIFORNIA EMISSIONS

ENGINE	TRANSMISSION		AXLES				GVWR
	4-SP	AUTO	#3.21	3.73	4.10	4.56	
-C30903							
\$\$L25 L6 4.8 Liter (292-1BBL)	MM4		—	—	GQ1	HC4	9000
		MX1	—	—	—	GQ1	9000
\$\$LT9 V8 5.7 Liter (350-4BBL)	MM4		—	GQ1	GT5	HC4	9000
		MX1	—	—	GQ1	HC4	9000
	MM4	%MX1	—	—	GQ1	HC4	#10000
\$\$LE8 V8 7.4 Liter (454-4BBL) (Reqs N41 & UA1)	MM4	MX1	#GQ1	GT4	GT5	*HC4	9000
	MM4	%MX1	—	GQ1	GT5	*HC4	#10000
LL4 Diesel 6.2 Liter V8 (379 Cu. In.)(Reqs 833)	MM4	MX1	—	—	GQ1	HC4	9000
	MM4	%MX1	—	—	GQ1	HC4	#10000
-C30943							
\$\$L25 L6 4.8 Liter (292-1BBL)	MM4		—	—	GQ1	HC4	9000
		MX1	—	—	—	GQ1	9000
\$\$LT9 V8 5.7 Liter (350-4BBL)	MM4		—	GQ1	GT5	HC4	9000
		MX1	—	—	GQ1	HC4	9000
	MM4	MX1	—	—	GQ1	HC4	9600
	MM4	%MX1	—	—	GQ1	HC4	#10000
\$\$LE8 V8 7.4 Liter (454-4BBL) (Reqs UA1 & N41)	MM4	MX1	#GQ1	GT4	GT5	*HC4	90/9600
	MM4	%MX1	—	GQ1	GT5	*HC4	#10000
LL4 Diesel 6.2 Liter V8 (379 Cu. In.)(Reqs 833)	MM4	MX1	—	—	GQ1	HC4	90/9600
	MM4	%MX1	—	—	GT5	GQ1	#10000
-K30903							
\$\$L25 L6 4.8 Liter (292-1BBL)	MM4	MX1	—	—	—	GQ1	9200
			—	—	—	GQ1	9200
\$\$LT9 V8 5.7 Liter (350-4BBL)	MM4		—	GQ1	GT5	HC4	9200
		MX1	—	—	GQ1	HC4	9200
	MM4	%MX1	—	—	GT5	GQ1	#10000
\$\$LE8 V8 7.4 Liter (454-4BBL)(Reqs UA1)	MM4	MX1	—	GQ1	GT5	*HC4	9200
	MM4	%MX1	—	GQ1	GT5	*HC4	#10000
LL4 Diesel 6.2 Liter V8 (379 Cu. In.)(Reqs 833)	MM4	MX1	—	—	GQ1	HC4	9200
	MM4	%MX1	—	—	GQ1	HC4	#10000
-K30943							
\$\$L25 L6 4.8 Liter (292-1BBL)	MM4	MX1	—	—	—	GQ1	9200
			—	—	—	GQ1	9200
\$\$LT9 V8 5.7 Liter (350-4BBL)	MM4		—	GQ1	GT5	HC4	9200
		MX1	—	—	GQ1	HC4	9200
	MM4	%MX1	—	—	GQ1	HC4	#10000
\$\$LE8 V8 7.4 Liter (454-4 BBL)(Reqs UA1)	MM4	MX1	—	GQ1	GT5	*HC4	9200
	MM4	%MX1	—	GQ1	GT5	*HC4	#10000
LL4 Diesel 6.2 Liter V8 (379 Cu. In.)(Reqs 833)	MM4	MX1	—	—	GQ1	HC4	9200
	MM4	%MX1	—	—	GQ1	HC4	#10000

%Reqs V02 Cooler
 #N/A G80 Locking Differential
 *W/MX1 Trans and %MX1 Reqs KC4 Cooler
 \$\$N/A NA6 High Altitude Emissions. With NA5 Emissions Satisfies High Altitude Requirements

■ High Altitude Emission Equipment (FOR EXHAUST SMOKE REDUCTION PURPOSES AT HIGH ALTITUDE; NOT REQUIRED TO SATISFY HIGH ALTITUDE EMISSION REGULATIONS).(REQS LL4 ENG)

C/K PICKUP GVWR SELECTOR—ALL STATES

GVWR Rating (lbs)	+GAWR (lbs)		Minimum Equipment Required for GVW Rating		
	Front	Rear	Tire Capacity (lbs ea)		Chassis Equipment
			Front	Rear	
C10/C1500 SERIES					
● 4900	2684	2684	1342	1342	Standard
■ 5200	2906	2906	1453	1453	■ Power Brakes (J50)
5600	★ 2950	3056	1703	1703	HD Rear Springs (G50); ■ Power Brakes (J50)
6100	★ 3250	3256	1843	1843	Extra Capacity Rear Springs (G51); HD Power Brakes (J55)
K10/K1500 SERIES					
6100	3550	3550	1775	1775	Standard

†GAWR's shown are the maximum for each axle with equipment listed. Other GAWR's are available, and they are determined as the minimum capacity of either axles, springs or tires.

- Not available on diesel engine models.
- Standard on diesel engine models.
- ★ Rated 3400 lbs. for diesel engine models.

FRONT AND REAR TIRE AVAILABILITY CHART—ALL STATES

C-K10/1500 SERIES

Spare tires to match either front or rear tires must be ordered
K10/1500 models require matching front and rear tread

Description	Capacity (lbs ea)	Highway		On-Off Road		Spare
		Front	Rear	*Front	Rear	
TUBELESS						
◆ #P195/75R15 Fiberglass Belted Radial	1342	XYP	YYP	—	—	ZYP
◆ #P195/75R15 White Wall Fiberglass Belted Radial	1342	XYQ	YYQ	—	—	ZYQ
#P205/75R15 Steel Belted Radial	1453	XJU	YJU	—	—	ZJU ZJT
#P205/75R15 White Wall Steel Belted Radial	1453	XJW	YJW	—	—	ZJW
#P225/75R15 Steel Belted Radial	1703	XLX	YLX	—	—	ZLX
#P225/75R15 White Wall Steel Belted Radial	1703	XLZ	YLZ	—	—	ZLZ
P235/75R15 Steel Belted Radial	1843	XBD	YBD	—	—	ZBD ZES
P235/75R15 White Wall Steel Belted Radial	1843	XBJ	YBJ	—	—	ZBJ
P235/75R15 White Letter Steel Belted Radial	1843	#XWV	#YWV	—	—	#ZWV *ZEB
%LR60-15B White Letter Rayon Belted Radial	1790	XTS	YTS	—	—	ZTS
▲31 x 10.50R15LT/B Steel Belted Radial	1775	—	—	*XUY	*YUY	*ZUY
▲31 x 10.50R15LT/B White Letter Steel Belted Radial	1775	—	—	*XUZ	*YUZ	*ZUZ

Available on C1 models only.

◆ Not available with B3J Diesel Equipment.

* Available on K1 models only.

% Available on C10703 only. Requires N67 or PA6 wheels.

▲ Requires N67 or PA6 wheels.

C/K PICKUP GVWR SELECTOR—ALL STATES

GVW Rating (lbs)	†GAWR (lbs)		Minimum Equipment Required for GVW Rating			
	Front	Rear	Tire Capacity (lbs ea)		Chassis Equipment	
			Front	Rear		
C20/2500 SERIES REGULAR CAB						
6400	3500	3880	1940	1940	Standard	
7200	3500	4630	1940	2315	HD Rear Springs (G50)	
8200	3800	5246	2623	2623	Front Stabilizer Bar (F59); HD Front Springs (F60); HD Shock Absorbers (F51); HD Power Brakes (J55); Ex. Cap. Rear Springs (G51)	
C20/2500/C6P SERIES REGULAR CAB						
8600	3800	6000	2623	3042	Standard	
K20/2500 SERIES REGULAR CAB						
6600	3700	3880	1940	1940	Standard	
K20/2500/C6P SERIES REGULAR CAB						
8600	3700	6000	3042	3042	Standard	
C20/2500 SERIES BONUS AND CREW CAB						
8600	3800	6000	2623	3042	Standard	

†GAWR's shown are the minimum for each axle with equipment listed. Other GAWR's are available, and they are determined as the minimum capacity of either axle, springs or tires.

● Requires LE3 L6 engine.

FRONT AND REAR TIRE AVAILABILITY CHART—ALL STATES

C-K20/2500 SERIES

Spare tire to match either front or rear tires is available at extra cost
K20/2500 models require matching front and rear tread

Description	Capacity (lbs ea)	Highway		On-Off Road		Spare
		Front	Rear	*Front	Rear	
TUBELESS (Requires LE3, LE6 or LE9 engine.)						
7.50R-16D Steel Belted Radial	2440	XWY	YWY	—	—	ZWY
		—	—	*XWX	YWX	ZWX
		—	—	—	#YWX	#ZWY
LT 215/85R16C Steel Belted Radial	1940	XYJ	YYJ	—	—	ZYJ
LT 215/85R16C Steel Belted Radial	1940	XYJ	—	—	—	—
LT 215/85R16D Steel Belted Radial	2315	—	YYK	—	—	ZYK
		—	—	—	#YYL	#ZYL
		—	—	—	#YYL	#ZYK
LT 215/85R16D Steel Belted Radial	2315	XYK	YYK	—	—	ZYK
		—	—	*XYL	YYL	ZYL
		—	—	—	#YYL	#ZYK
LT 235/85R16D Steel Belted Radial	2623	XYM	YYM	—	—	ZYM
LT 235/85R16E Steel Belted Radial	3042	XYN	YYN	—	—	ZYN
TUBELESS (Requires LE3, LE6, LL4 or L25 engine.)						
LT 235/85R16D Steel Belted Radial	2623	XYM	—	—	—	—
LT 235/85R16E Steel Belted Radial	3042	—	YYN	—	#YYT	ZYN
		—	—	—	#YYT	ZYT
LT 235/85R16E Steel Belted Radial	3042	XYN	YYN	—	—	ZYN
		—	—	*XYT	YYT	ZYT
		—	—	—	#YYT	#ZYN

*On-Off road front tires available on K2 models only.

#Not available on K2 models.

▲Available on K2 models only.

C/K PICKUP

GVW SELECTOR — ALL STATES

GVW Rating (lbs)	+GAWR (lbs)		Minimum Equipment Required for GVW Rating			
			Tire Capacity (lbs ea)			Chassis Equipment
	Front	Rear	Front	Rear		

C30/3500 SERIES REGULAR CAB

9000	3800	6084	2623	3042	Standard
•10,000	3800	7056	1940	1764 (Duals)	Dual Rear Wheel Provisions (R05)

C30/3500 SERIES BONUS CAB AND CREW CAB

9000	4000	6084	2623	3042	Standard
•9600	4000	6084	2623	3042	Camper Special Chassis Equipment (Z81)
•10,000	3880	7500	1940	2105 (Duals)	Dual Rear Wheel Provisions (R05)

K30/3500 SERIES REGULAR CAB

9200	4500	6084	2623	3042	Standard
•10,000	4500	7500	2315	2105 (Duals)	Dual Rear Wheel Provisions (R05)

K30/3500 SERIES BONUS CAB AND CREW CAB

9200	4500	6084	2623	3042	Standard
•10,000	4500	7500	2315	2105 (Duals)	Dual Rear Wheel Provisions (R05)

†GAWR's shown are the maximum for each equipment listed. Other GAWR's are available, and they are determined as the minimum capacity of either axle, ~~using~~ tires.

- Requires V8 engine.
- *Fleetside/Wideside Pickups only.

FRONT AND REAR TIRE AVAILABILITY CHART — ALL STATES

C-K30/3500 SERIES

Spare tire to match ~~any~~ front or rear tires is available at extra cost
K30/3500 models require matching front and rear tread

Description	Capacity (lbs each)		Highway			On-Off Road			Spare
	Front/Single Rear	Dual Rear	Front	Single Rear	Dual Rear	*Front	Single Rear	Dual Rear	
TUBELESS Steel Belted Radial									
•LT215/85R16C	1940	1764	XYJ	—	YYJ	—	—	—	ZYJ
#LT215/85R16C	1940	—	XYJ	—	—	—	—	—	—
#LT215/85R16D	—	2105	—	—	YYK	—	—	YYL YYL	ZYK ZYL ZYK
LT215/85R16D	2315	2105	XYK	—	YYK	—	—	YYL #YYL	ZYK ZYL #ZYK
LT235/85R16D	2623	—	XYM	—	—	—	—	—	—
LT235/85R16E	3042	—	XYN	YYN	—	—	—	—	ZYN †ZYT
TUBE-TYPE Nylon									
♦7.50-16C	2060	1815	XPB	—	YPB	—	—	— YPC YPC	ZPB ZPC ZPB
#7.50-16C	2060	—	XPB	—	—	—	—	—	—
#7.50-16D	—	2140	—	—	YPF	—	—	— YPG YPG	ZPF ZPG ZPF
7.50-16D	2440	2140	XPF	—	YPF	—	—	— YPG #YPG	ZPF ZPG #ZPF

- #C3 models only.
- *On-Off road front tires available on K3 models only.
- †K3 models only.
- ♦C30903 models only.

NOTES

C/K PICKUPS

THE FOLLOWING EQUIPMENT IS STANDARD ON DIESEL ENGINE MODELS (ALSO SEE STANDARD SPECIFICATIONS PAGES)

- Low Coolant Sensor
- Poly-wrapped Paper Element Air Cleaner
- Auxiliary Engine Oil Cooler provided with 4.56 ratio rear axle (in addition to cooler in radiator tank)
- Power Steering
- Engine Block Heater
- Water/fuel separator unit which incorporates a water sensor and sending unit, a fuel filter, a fuel heater and water drain capability
- Hydraulic Power-assisted Brakes
- K81 66-amp Generator
- Engine Oil Cooler (located in radiator tank)
- Dual 550 Cold Cranking Amp/115 min. Reserve Capacity Batteries
- HD Radiator
- Dual Exhaust System
- Additional Insulation:
 - Cab-to-fender insulators
 - Fiberglass hood insulator
 - Fiberglass engine compartment firewall insulator
 - Cowl side spray-on deadener
 - Driver compartment dash mat with increased mastic layer
 - Resinated cotton and mastic floor insulation
 - Full cowl interior trim panels with resinated cotton insulation
 - Vinyl-coated rubber floor mat for regular cab models
- Warning Lights: Glow Plugs, Water-in-fuel (or fuel filter), and Low Coolant
- Diesel Engine Identification:
 - Hood ornament
 - Fender nameplates
 - Tailgate nameplate (Fleetside/Wideside models only)
 - "Diesel Fuel Only" filler cap and label

C-K PICKUP

2-WHEEL DRIVE (4900-lb - 10,000-lb GVW)
4-WHEEL DRIVE (6100-lb - 10,000-lb GVW)

1984 VEHICLES WITH STANDARD EQUIPMENT

Prices shown are effective with vehicles produced on and after February 13, 1984

Description	Model Number	Body Code	Wheel Base	Factory D&H(s)	List Price	Mfr's Suggested Retail Price*	Group Number
<i>(All models have standard cab unless otherwise indicated)</i>							
◆ 6-Cylinder 4.3 Liter (250 Cu. In.) 2 BBL L6 Gasoline Engine-Engine Ordering Code LE3							
C10/C1500 Standard 2-Wheel Drive							
Stepside/Fenderside (6 1/2-ft)	CC/TC10703	E62	117.5"	N.A.	7101.00	7101.00	14
Fleetside/Widenside (6 1/2-ft)	CC/TC10703	E63	117.5"	N.A.	6970.00	6970.00	14
Fleetside/Widenside (8-ft)	CC/TC10903	E63	131.5"	N.A.	7127.00	7127.00	14
C20/C2500 Standard 2-Wheel Drive							
Stepside/Fenderside (8-ft)	CC/TC20903	E62	131.5"	.20	8319.00	8319.20	14
Fleetside/Widenside (8-ft)	CC/TC20903	E63	131.5"	.20	8188.00	8188.20	14
K10/K1500 Standard 4-Wheel Drive							
Stepside/Fenderside (6 1/2-ft)	CK/TK10703	E62	117.5"	N.A.	9484.00	9484.00	14
Fleetside/Widenside (6 1/2-ft)	CK/TK10703	E63	117.5"	N.A.	9333.00	9333.00	14
Fleetside/Widenside (8-ft)	CK/TK10903	E63	131.5"	N.A.	9490.00	9490.00	14
◆ 6-Cylinder 4.3 Liter (292 Cu. In.) 1 BBL L6 Gasoline Engine-Engine Ordering Code L25							
C20/C2500 Standard H.D. Chassis 2-Wheel Drive							
Stepside/Fenderside (8-ft)	CC/TC20903	E62 & C6P	131.5"	3.94	8828.00	8832.94	14
Fleetside/Widenside (8-ft)	CC/TC20903	E63 & C6P	131.5"	3.94	8698.00	8701.94	14
C20/C2500 Standard 2-Wheel Drive							
Bonus Cab	CC/TC20943	E63 & YG4	164.5"	3.94	9641.00	9644.94	14
Crew Cab	CC/TC20943	E63 & AS3	164.5"	3.94	9971.00	9974.94	14
C30/C3500 Standard 2-Wheel Drive							
Stepside/Fenderside (8-ft)	CC/TC30903	E62	131.5"	3.94	8962.00	8965.94	14
Fleetside/Widenside (8-ft)	CC/TC30903	E63	131.5"	3.94	8830.00	8833.94	14
Bonus Cab	CC/TC30943	E63 & YG4	164.5"	3.94	9811.00	9814.94	14
Crew Cab	CC/TC30943	E63 & AS3	164.5"	3.94	10142.00	10145.94	14
K20/K2500 Standard H.D. Chassis 4-Wheel Drive							
Stepside/Fenderside (8-ft)	CK/TK20903	E62 & C6P	131.5"	3.94	10364.00	10367.94	14
Fleetside/Widenside (8-ft)	CK/TK20903	E63 & C6P	131.5"	3.94	10233.00	10236.94	14
K30/K3500 Standard 4-Wheel Drive							
Fleetside/Widenside (8-ft)	CK/TK30903	E63	131.5"	3.94	11280.00	11283.94	14
Bonus Cab	CK/TK30943	E63 & YG4	164.5"	3.94	12142.00	12145.94	14
Crew Cab	CK/TK30943	E63 & AS3	164.5"	3.94	12473.00	12476.94	14

- ★ Manufacturer's Suggested Retail Prices do not include applicable destination charges, state and local taxes, license fees, optional equipment or accessories or other items or services.
- ◆ Refer to Dealer Order Guide for California Requirements.

MODELS CONTINUED ON FOLLOWING PAGE

(a) D & H Charges on vehicle and optional equipment include reimbursement to ordering Division for any tax that it has paid, incurred or agreed to pay thereon.

C-K PICKUP

VEHICLES WITH STANDARD EQUIPMENT

Prices shown are effective with vehicles produced on and after February 13, 1984

Description	Model Number	Body Code	Wheel Base	Factory D&H(a)	List Price	Mfr's Suggested Retail Price*	Group Number
◆ 8-Cylinder 5.7 Liter (350 Cu. In.) 4 BBL V8 Gasoline Engine-Engine Ordering Code LS9							
K20/K2500 Series 4-Wheel Drive							
Stepside/Fenderside (8-ft)	CK/03	E62	131.5"	.20	10387.00	10387.20	14
Fleetside/Wideside (8-ft)	CK/03	E63	131.5"	.20	10256.00	10256.20	14
◆ 8-Cylinder 6.2 Liter (375 Cu. In.) L.D. Diesel V8 Engine-Engine Ordering Code LH6							
C10/C1500 Series 2-Wheel Drive							
Stepside/Fenderside (6 1/2-ft)	CC/03	E62 & B3J	117.5"	N.A.	10145.00	10145.00	14
Fleetside/Wideside (6 1/2-ft)	CC/03	E63 & B3J	117.5"	N.A.	10014.00	10014.00	14
Fleetside/Wideside (8-ft)	CC/03	E63 & B3J	131.5"	N.A.	10171.00	10171.00	14
C20/C2500 Series 2-Wheel Drive							
Stepside/Fenderside (8-ft)	CC/03	E62 & B3J	131.5"	.20	10926.00	10926.20	14
Fleetside/Wideside (8-ft)	CC/03	E63 & B3J	131.5"	.20	10795.00	10795.20	14
K10/K1500 Series 4-Wheel Drive							
Stepside/Fenderside (6 1/2-ft)	CK/03	E62 & B3J	117.5"	N.A.	11761.00	11761.00	14
Fleetside/Wideside (6 1/2-ft)	CK/03	E63 & B3J	117.5"	N.A.	11630.00	11630.00	14
Fleetside/Wideside (8-ft)	CK/03	E63 & B3J	131.5"	N.A.	11787.00	11787.00	14
K20/K2500 Series 4-Wheel Drive							
Stepside/Fenderside (8-ft)	CK/03	E62 & B3J	131.5"	.20	12592.00	12592.20	14
Fleetside/Wideside (8-ft)	CK/03	E63 & B3J	131.5"	.20	12461.00	12461.20	14

- ★ Manufacturer's Suggested Retail Prices do not include applicable destination charges, state and local taxes, license fees, optional equipment or accessories or special items or services.
- ◆ Refer to Dealer Order Guide for California Requirements.

MODELS CONTINUED ON FOLLOWING PAGE

(a) D & H Charges on vehicle and optional equipment include reimbursement to ordering Division for any tax that it has paid, incurred or agreed to pay thereon.

C-K PICKUP

1984 VEHICLES WITH STANDARD EQUIPMENT

Prices shown are effective with vehicles produced on and after February 13, 1984

Description	Model Number	Body Code	Wheel Base	Factory D&H(a)	List Price	Mfr's Suggested Retail Price*	Group Number
◆ 8-Cylinder 6.2 Liter (379 Cu. In.) H.D. Diesel V8 Engine-Engine Ordering Code LL4							
C20/C2500 Series H.D. Chassis 2-Wheel Drive							
Stepside/Fenderside (8-ft)	CC/TC2098B	E62 & C6P & B3J	131.5"	3.94	11436.00	11439.94	14
Fleetside/Wideside (8-ft)	CC/TC2098B	E63 & C6P & B3J	131.5"	3.94	11305.00	11308.94	14
C20/C2500 Series 2-Wheel Drive							
Bonus Cab	CC/TC2098B	E63 & YG4 & B3J	164.5"	3.94	12248.00	12251.94	14
Crew Cab	CC/TC2098B	E63 & A83 & B3J	164.5"	3.94	12578.00	12581.94	14
C30/C3500 Series 2-Wheel Drive							
Stepside/Fenderside (8-ft)	CC/TC3098B	E62 & B3J	131.5"	3.94	11369.00	11372.94	14
Fleetside/Wideside (8-ft)	CC/TC3098B	E63 & B3J	131.5"	3.94	11237.00	11240.94	14
Bonus Cab	CC/TC3098B	E63 & YG4 & B3J	164.5"	3.94	12218.00	12221.94	14
Crew Cab	CC/TC3098B	E63 & A83 & B3J	164.5"	3.94	12549.00	12552.94	14
K20/K2500 Series H.D. Chassis 2-Wheel Drive							
Stepside/Fenderside (8-ft)	CK/TK2098B	E62 & C6P & B3J	131.5"	3.94	12739.00	12742.94	14
Fleetside/Wideside (8-ft)	CK/TK2098B	E63 & C6P & B3J	131.5"	3.94	12608.00	12611.94	14
K30/K3500 Series 4-Wheel Drive							
Fleetside/Wideside (8-ft)	CK/TK3098B	E63 & B3J	131.5"	3.94	13457.00	13460.94	14
Bonus Cab	CK/TK3098B	E63 & YG4 & B3J	164.5"	3.94	14319.00	14322.94	14
Crew Cab	CK/TK3098B	E63 & A83 & B3J	164.5"	3.94	14650.00	14653.94	14

- ★ Manufacturer's Suggested Retail Price does not include applicable destination charges, state and local taxes, license fees, optional equipment or accessories or special items or services.
 ◆ Refer to Dealer Order Guide for California Requirements.

OPTIONS AND ACCESSORIES WHEN INSTALLED BY GENERAL MOTORS

Prices shown are effective with vehicles produced on and after February 13, 1984

Description	Option Number	Factory D&H(a)	List Price	Mfr's Suggested Retail Price◇
Scottsdale/High Sierra: (See Interior and Exterior Color Selection Charts) Available only when deluxe cloth or custom vinyl seats are specified on Regular Cab. Includes bright rear window and windshield moldings, side marker lamp bezels, nameplates on front fenders and instrument panel, U37 Cigarette Lighter, dual horns, cab back illumination, C91 Dome Lamp, special insulation and color vinyl coated floor mat.				
Stepside/Fenderside only. Also includes plastic door trim panels	Z82	N.A.	241.00	241.00

- (a) D & H Charges on vehicle and optional equipment include reimbursement to ordering Division for any tax that it has paid, incurred or agreed to pay thereon.
 ◇ State and local taxes not included.

C-K PICKUP

OPTIONS AND ACCESSORIES WHEN INSTALLED BY GENERAL MOTORS

Prices shown are for vehicles produced on and after February 13, 1984

Description	Option Number	Factory D&H(a)	List Price	Mfr's Suggested Retail Price ◊
Scottsdale/High Sierra: (Continued)				
Fleetside/Wideside only. Also includes bright side trim. Without R05 Dual Rear Wheels.				
Regular Cab only. Also includes plastic door trim panels				
Without YJ6 Value Decor Package				
B84 Black Side Moldings	Z62	N.A.	357.00	357.00
Bonus Cab only	Z62	N.A.	306.00	306.00
Crew Cab only	Z62	N.A.	315.00	315.00
Regular Cab only. Also includes plastic door trim panels.				
With YJ6 Value Decor Package	Z62	N.A.	246.00	246.00
With R05 Dual Rear Wheels.				
Regular Cab only. Also includes plastic door trim panels	Z62	N.A.	250.00	250.00
Bonus Cab only	Z62	N.A.	199.00	199.00
Crew Cab only	Z62	N.A.	208.00	208.00
Silverado/Sierra Classic: Available only with custom cloth or custom vinyl seats are specified. Includes bright side marker lamp bezels, nameplates on front fenders, bright windshield and rear window moldings, color-keyed carpeting for front seat area, plastic door trim panels with storage pockets and bright brushed-finish accents, VZ3 Deluxe Front Appearance, nameplate on deluxe instrument panel, U37 Cigarette Lighter, visor vanity mirror, custom ceiling panel, headliner, C91 Dome Lamp, cab back insulation, Z53 Voltmeter, Temperature and Oil Pressure Gauges, mirrors and special insulation.				
Stepside/Fenderside only. Also includes cab back panel applique molding				
Regular Cab only	YE9	N.A.	647.00	647.00
Fleetside/Wideside only. Also includes bright side trim, YG3 Deluxe Molding Package and tailgate applique.				
Without R05 Dual Rear Wheels.				
Regular Cab only.				
Without ZY5 Exterior Decor Package				
cab back panel applique molding	YE9	N.A.	824.00	824.00
With ZY5 Exterior Decor Package	YE9	N.A.	795.00	795.00
Bonus Cab only.				
Without ZY5 Exterior Decor Package				
cab back panel applique molding	YE9	N.A.	888.00	888.00
With ZY5 Exterior Decor Package	YE9	N.A.	857.00	857.00
Crew Cab only. Also includes rear seat carpeting.				
Without ZY5 Exterior Decor Package				
cab back panel applique molding	YE9	N.A.	967.00	967.00
With ZY5 Exterior Decor Package	YE9	N.A.	938.00	938.00
With R05 Dual Rear Wheels.				
Regular Cab only.				
Without ZY9 Big Dooley Special Two-Tone Paint.				
Also includes cab back panel applique molding	YE9	N.A.	675.00	675.00
With ZY9 Big Dooley Special Two-Tone Paint	YE9	N.A.	629.00	629.00
Bonus Cab only. Also includes cab back insulation.				
Without ZY9 Big Dooley Special Two-Tone Paint.				
Also includes cab back panel applique molding	YE9	N.A.	737.00	737.00
With ZY9 Big Dooley Special Two-Tone Paint	YE9	N.A.	691.00	691.00
Crew Cab only. Also includes rear seat carpeting and cab back insulation.				
Without ZY9 Big Dooley Special Two-Tone Paint.				
Also includes cab back panel applique molding	YE9	N.A.	818.00	818.00
With ZY9 Big Dooley Special Two-Tone Paint	YE9	N.A.	772.00	772.00
Seat Trim: (See Interior and Exterior Color Selection Chart for availability and ordering information).				
V**1 Vinyl Bench			NO ADDITIONAL CHARGE	

(a) D & H Charges on vehicle and optional equipment are the reimbursement to ordering Division for any tax that it has paid, incurred or agreed to pay thereon.
 ◊ State and local taxes not included.

C-K PICKUP

OPTIONS AND ACCESSORIES WHEN INSTALLED BY GENERAL MOTORS¹⁾

Prices shown are effective with vehicles produced on and after February 13, 1984

Description	Option Number	Factory D&H(a)	List Price	Mfr's Suggested Retail Price [◇]
Seat Trim: (Continued)				
<i>C**1 Deluxe Cloth Bench. Regular Cab only. Not available when YE9 is specified</i>				
Without Z62		N.A.	65.00	65.00
With Z62		N.A.	15.00	15.00
<i>L**1 Custom Cloth Bench.</i>				
<i>Regular Cab only. Available only when YE9 is specified ..</i>				
<i>Bonus Cab only. Available only when Z62 or YE9 is specified.</i>				
With Z62		N.A.	50.00	50.00
With YE9		<i>NO ADDITIONAL CHARGE</i>		
<i>Crew Cab only. Available only when Z62 or YE9 is specified.</i>				
With Z62		N.A.	100.00	100.00
With YE9		<i>NO ADDITIONAL CHARGE</i>		
<i>X**1 Custom Vinyl Bench</i>				
<i>Regular Cab only</i>				
Without Z62 or YE9		N.A.	50.00	50.00
With Z62 or YE9		<i>NO ADDITIONAL CHARGE</i>		
<i>Bonus Cab only.</i>				
With Z62		N.A.	50.00	50.00
With YE9		<i>NO ADDITIONAL CHARGE</i>		
<i>Crew Cab only.</i>				
With Z62		N.A.	100.00	100.00
With YE9		<i>NO ADDITIONAL CHARGE</i>		
Paints, Exterior: (See Interior and Exterior Color Selection Chart for ordering information and paint application).				
<i>Solid</i>				
	ZY1	<i>NO ADDITIONAL CHARGE</i>		
<i>Conventional Two-Tone.</i>				
<i>Regular Cab only.</i>				
Without YE9. Includes cab back panel applique moldings	ZY2	N.A.	72.00	72.00
With YE9	ZY2	N.A.	43.00	43.00
<i>Bonus Cab or Crew Cab only.</i>				
Without YE9. Includes cab back panel applique moldings	ZY2	N.A.	89.00	89.00
With YE9	ZY2	N.A.	60.00	60.00
<i>Special Two-Tone. Fleetside/Wideside only.</i>				
<i>Regular Cab only.</i>				
Without Z62 or YE9. Includes YG1 Custom Molding Package	ZY3	N.A.	317.00	317.00
With Z62	ZY3	N.A.	193.00	193.00
With YE9	ZY3	N.A.	165.00	165.00
<i>Bonus Cab or Crew Cab only.</i>				
Without Z62 or YE9. Includes YG1 Custom Molding Package	ZY3	N.A.	323.00	323.00
With Z62	ZY3	N.A.	199.00	199.00
With YE9	ZY3	N.A.	171.00	171.00
<i>Deluxe Two-Tone. Fleetside/Wideside only.</i>				
<i>Regular Cab only.</i>				
Without Z62 or YE9. Includes YG1 Custom Molding Package	ZY4	N.A.	357.00	357.00
With Z62	ZY4	N.A.	233.00	233.00
With YE9	ZY4	N.A.	178.00	178.00
<i>Bonus Cab or Crew Cab only.</i>				
Without Z62 or YE9. Includes YG1 Custom Molding Package	ZY4	N.A.	372.00	372.00
With Z62	ZY4	N.A.	248.00	248.00
With YE9	ZY4	N.A.	191.00	191.00

(a) D & H Charges on vehicle and optional equipment include reimbursement to ordering Division for any tax that it has paid, incurred or agreed to pay thereon.
[◇] State and local taxes not included.

C-K PICKUP

OPTIONS AND ACCESSORIES WHEN INSTALLED BY GENERAL MOTORS

Prices shown are effective with vehicles produced on and after February 13, 1984

Description	Option Number	Factory D&H(a)	List Price	Mfr's Suggested Retail Price ◊
Paints, Exterior: (Continued)				
<i>Exterior Decor Package. Fleetside /Wideside only. Includes dual-tone body side and rear decal striping. Also includes hood ornament when B3J Diesel Equipment is not specified. Regular Cab only.</i>				
Without Z62 or YE9. Includes YG1 Custom Molding Package	ZY5	N.A.	541.00	541.00
With Z62	ZY5	N.A.	417.00	417.00
With YE9	ZY5	N.A.	389.00	389.00
<i>Bonus Cab or Crew Cab only.</i>				
Without Z62 or YE9. Includes YG1 Custom Molding Package	ZY5	N.A.	556.00	556.00
With Z62	ZY5	N.A.	432.00	432.00
With YE9	ZY5	N.A.	404.00	404.00
<i>Special Big Dooley Special Two-Tone. Fleetside/Wideside only. Available only when R05 Dual Rear Wheels are specified. Includes dual-tone body side and rear decal striping. Also includes hood ornament when B3J Diesel Equipment is not specified.</i>				
Without Z62	ZY9	N.A.	444.00	444.00
With Z62	ZY9	N.A.	426.00	426.00
Emission Systems: Dealer Note - One of the following emission options must be specified. (See Power Teams Chart for availability and complete specifications).				
<i>California Emission Requirements. Includes all testing, equipment and/or certification necessary for registration in the State of California. Not available when NA6 High Altitude Emissions is specified.</i>				
With LE3 4.1 Liter, LF3 5.7 Liter or LS9 5.7 Liter Engine	YF5	N.A.	235.00	235.00
With L25 4.8 Liter, LT9 5.7 Liter or LE8 7.4 Liter Engine	YF5	N.A.	235.00	235.00
With B3J Diesel Equipment	YF5	N.A.	235.00	235.00
<i>High Altitude Emission Equipment. Available only when LE9 5.0 Liter, LE3 4.1 Liter, LS9 5.7 Liter Engine or B3J Diesel Equipment is specified. Not available when NA5 Standard or YF5 California Emissions is specified.</i>				
	NA6		NO ADDITIONAL CHARGE	
<i>Standard Emission Equipment. Not available when LF3 5.0 Liter Engine on C1 or LS9 5.7 Liter Engine on K1-2 series is specified. Also not available when NA6 High Altitude Emissions or YF5 California Emissions are specified</i>				
	NA5		NO ADDITIONAL CHARGE	
Engines: (See Power Teams Chart for availability and complete specifications).				
Gasoline.				
4.1 Liter (250 Cu. In.) 2 BBL L6. C-K1 or C2 Series without C6P H.D. Chassis	LE3		NO ADDITIONAL CHARGE	
4.8 Liter (292 Cu. In.) 1 BBL L6: C-K2 Series with C6P H.D. Chassis or C-K3 Series	L25		NO ADDITIONAL CHARGE	
5.0 Liter (305 Cu. In.) 4 BBL V8. C-K1 or C2 Series only. Not available when C6P H.D. Chassis is specified	LE9	N.A.	350.00	350.00
5.0 Liter (305 Cu. In.) 4 BBL V8. C1 Series only. Available only when YF5 California Emissions Requirements and MXQ Automatic Overdrive Transmission are specified ..	LF3	N.A.	360.00	350.00
5.7 Liter (350 Cu. In.) 4 BBL V8. Standard on K2 Series without C6P H.D. Chassis. Not available on C1 Series, C2 Bonus and Crew Cab or C-K3 Series				
K1 Series only. Available only when YF5 California Emissions is specified	LS9	N.A.	531.00	531.00
C2 Regular Cab. Available only when YF5 California Emissions Requirements is specified. Not available when C6P H.D. Chassis is specified	LS9	N.A.	531.00	531.00
5.7 Liter (350 Cu. In.) 4 BBL V8. Available on C6P H.D. Chassis, C2 Bonus and Crew Cab or C-K3 Series	LT9	N.A.	500.00	500.00
7.4 Liter (454 Cu. In.) 4 BBL V8. C2-3 or K3 Series only. Available only when UA1 H.D. Battery is specified.				
C2-3 Series only. Available only when N41 Power Steering is specified. C2 Regular Cab also available only when C6P H.D. Chassis is specified	LE8	N.A.	613.00	613.00
K3 Series	LE8	N.A.	613.00	613.00
Diesel.				

(a) D & H Charges on vehicle and optional equipment include reimbursement to ordering Division for any tax that it has paid, incurred or agreed to pay thereon.
 ◊ State and local taxes not included.

C-K PICKUP

OPTIONS AND ACCESSORIES WHEN INSTALLED BY GENERAL MOTORS

Prices shown are effective with vehicles produced on and after February 13, 1984

Description	Option Number	Factory D&H(s)	List Price	Mfr's Suggested Retail Price ◊
Engines: (Continued)				
6.2 Liter (379 Cu. In.) L.D. Diesel. C-K1-2 Regular Cab only. Not available when C6P H.D. Chassis is specified. Available only when B3J Diesel Equipment is specified.	LH6			
C-K-1, 2 Series only				NO ADDITIONAL CHARGE
6.2 Liter (379 Cu. In.) H.D. Diesel. C-K2-3 Series only. Available only when B3J Diesel Equipment is specified. C-K2 Regular Cab also available only when C6P H.D. Chassis is specified	LL4			
				NO ADDITIONAL CHARGE
Transmissions: (See Power Teams Chart for availability and complete specifications)				
3-Speed Automatic.				
C1 Series only. Available only when LE9 5.0 Liter or LE3 4.1 Liter Engine is specified	MX1	N.A.	492.00	492.00
C-K2-3 Series only. C-K2 Regular Cab available only when C6P H.D. Chassis is specified	MX1	N.A.	492.00	492.00
	MM3			NO ADDITIONAL CHARGE
3-Speed Manual. C1 Series only				
4-Speed Manual. Standard on C-K2-3 Series. Standard on K1 Series with B3J Diesel Equipment is specified.				
C1 Series. Not available when LF3 5.0 Liter or LS9 5.7 Liter Engine is specified. Also not available when YF5 California Emissions is specified	MM4	N.A.	205.00	205.00
C1 Series without B3J Diesel Equipment	MM4			NO ADDITIONAL CHARGE
C1 Series with B3J Diesel Equipment or K1 Series				
4-Speed Manual with Overdrive. Standard on C1 Series when B3J Diesel Equipment is specified. Standard on K1 Series when B3J Diesel Equipment is not specified.				
C1 Series when gasoline engines are specified	MM7	N.A.	283.00	283.00
K1 Series with B3J Diesel Equipment	MM7	N.A.	78.00	78.00
4-Speed Automatic with Overdrive. C-K1-2 Regular Cab only	MX0	N.A.	650.00	650.00
Axles, Rear: (See Power Teams Chart for option number selection, availability and complete specifications)				
Optional Ratio	G80	N.A.	36.00	36.00
Locking Differential		N.A.	230.00	230.00
Tires: (See Tire Charts for Tire Availability)				
Spare tire carrier included when spare tires is specified on C-K-2,3 series				
All rim sizes are 6.00" except when N67 or PA6 Wheels are specified on C-K1 Series.				
All rim sizes are 6.50" on C-K2 Series or C-K3 Series without R05 Dual Rear Wheels.				
All rim sizes are 6.00" on C-K3 Series with R05 Dual Rear Wheels.				
Dealer Note: When dual rear tires are specified, R05 Dual Rear Wheels will be applied to the order. THIS EQUIPMENT IS NOT PRICED IN THE TIRE OPTION AND WILL BE REFLECTED ON THE INVOICE SEPARATELY.				
For complete specifications and ordering information, see "OTHER OPTIONS" Section.				
TUBELESS				
P195/75R15 Highway Fiberglass Belted Radial Ply Blackwall (Maximum Capacity 1342 lbs.)				
C1 Series only. Not available when B3J Diesel Equipment is specified.				
Front (Standard)	XYP			NO ADDITIONAL CHARGE
Rear (Standard)	YYP			NO ADDITIONAL CHARGE
Spare (Standard)	ZYP			NO ADDITIONAL CHARGE
P195/75R15 Highway Fiberglass Belted Radial Ply Whitewall (Maximum Capacity 1342 lbs.)				
C1 Series only. Not available when B3J Diesel Equipment is specified.				
Front	XYQ	N.C.	24.00	24.00
Rear	YYQ	N.C.	24.00	24.00
Spare	ZYQ	N.C.	12.00	12.00

(a) D & H Charges on vehicle and optional equipment include reimbursement to ordering Division for any tax that it has paid, incurred or agreed to pay thereon.
 ◊ State and local taxes not included.

C-K PICKUP

OPTIONS AND ACCESSORIES WHEN INSTALLED BY GENERAL MOTORS

Prices shown are effective with vehicles produced on and after February 13, 1984

Description	Option Number	Factory D&H(a)	List Price	IMfr's Suggested Retail Price◇
Tires: (Continued)				
P205/75R15 Highway Steel Belted Radial Ply Blackwall (Maximum Capacity 1453-lbs)				
C1 Series only.				
Front				
Without B3J Diesel Equipment	XJU	N.C.	58.00	58.00
With B3J Diesel Equipment	XJU	NO ADDITIONAL CHARGE		
Rear				
Without B3J Diesel Equipment	YJU	N.C.	58.00	58.00
With B3J Diesel Equipment	YJU	NO ADDITIONAL CHARGE		
Spare				
Without B3J Diesel Equipment	ZJU	N.C.	28.00	28.00
With B3J Diesel Equipment	ZJU	NO ADDITIONAL CHARGE		
P205/75R15 Highway Steel Belted Radial Ply Whitewall (Maximum Capacity 1453-lbs)				
C1 Series only.				
Front				
Without B3J Diesel Equipment	XJW	N.C.	82.00	82.00
With B3J Diesel Equipment	XJW	N.C.	26.00	26.00
Rear				
Without B3J Diesel Equipment	YJW	N.C.	82.00	82.00
With B3J Diesel Equipment	YJW	N.C.	26.00	26.00
Spare				
Without B3J Diesel Equipment	ZJW	N.C.	41.00	41.00
With B3J Diesel Equipment	ZJW	N.C.	13.00	13.00
P205/75R15 On-Off Road Steel Belted Radial Ply Blackwall (Maximum Capacity 1453-lbs)				
C1 Series only				
Rear				
Without B3J Diesel Equipment	YJT	N.C.	76.00	76.00
With B3J Diesel Equipment	YJT	N.C.	20.00	20.00
Spare				
Without B3J Diesel Equipment	ZJT	N.C.	38.00	38.00
With B3J Diesel Equipment	ZJT	N.C.	10.00	10.00
P225/75R15 Highway Steel Belted Radial Ply Blackwall (Maximum Capacity 1703-lbs)				
C1 Series only				
Front				
Without B3J Diesel Equipment	XLX	N.C.	104.00	104.00
With B3J Diesel Equipment	XLX	N.C.	48.00	48.00
Rear				
Without B3J Diesel Equipment	YLX	N.C.	104.00	104.00
With B3J Diesel Equipment	YLX	N.C.	48.00	48.00
Spare				
Without B3J Diesel Equipment	ZLX	N.C.	52.00	52.00
With B3J Diesel Equipment	ZLX	N.C.	24.00	24.00
P225/75R15 Highway Steel Belted Radial Ply Whitewall (Maximum Capacity 1703-lbs)				
C1 Series only				
Front				
Without B3J Diesel Equipment	XLZ	N.C.	138.00	138.00
With B3J Diesel Equipment	XLZ	N.C.	82.00	82.00
Rear				
Without B3J Diesel Equipment	YLZ	N.C.	138.00	138.00
With B3J Diesel Equipment	YLZ	N.C.	82.00	82.00
Spare				
Without B3J Diesel Equipment	ZLZ	N.C.	69.00	69.00
With B3J Diesel Equipment	ZLZ	N.C.	41.00	41.00

(a) D & H Charges on vehicle and optional equipment include reimbursement to ordering Division for any tax that it has paid, incurred or agreed to pay thereon.
 ◇ State and local taxes not included.

C-K PICKUP

OPTIONS AND ACCESSORIES WHEN INSTALLED BY GENERAL MOTORS

Prices shown are effective with vehicles produced on and after February 13, 1984

Description	Option Number	Factory D&H(a)	List Price	Mfr's Suggested Retail Price ◊
Tires: (Continued)				
<i>P235/75R15 Highway Steel Belted Radial Ply Blackwall</i> (Maximum Capacity 1843-lbs)				
Front				
C1 Series only				
Without B3J Diesel Equipment	XBD	N.C.	130.00	130.00
With B3J Diesel Equipment	XBD	N.C.	74.00	74.00
K1 Series only (Standard)	XBD	NO ADDITIONAL CHARGE		
Rear				
C1 Series only				
Without B3J Diesel Equipment	YBD	N.C.	130.00	130.00
With B3J Diesel Equipment	YBD	N.C.	74.00	74.00
K1 Series only (Standard)	YBD	NO ADDITIONAL CHARGE		
Spare				
C1 Series only				
Without B3J Diesel Equipment	ZBD	N.C.	85.00	85.00
With B3J Diesel Equipment	ZBD	N.C.	37.00	37.00
K1 Series only (Standard)	ZBD	NO ADDITIONAL CHARGE		
<i>P235/75R15 On-Off Road Steel Belted Radial Ply Blackwall</i> (Maximum Capacity 1843-lbs)				
Front				
K1 Series only	XES	N.C.	20.00	20.00
Rear				
C1 Series only				
Without B3J Diesel Equipment	YES	N.C.	150.00	150.00
With B3J Diesel Equipment	YES	N.C.	94.00	94.00
K1 Series only	YES	N.C.	20.00	20.00
Spare				
C1 Series only				
Without B3J Diesel Equipment	ZES	N.C.	75.00	75.00
With B3J Diesel Equipment	ZES	N.C.	47.00	47.00
K1 Series only	ZES	N.C.	10.00	10.00
<i>P235/75R15 Highway Steel Belted Radial Ply Whitewall</i> (Maximum Capacity 1843-lbs)				
Front				
C1 Series only				
Without B3J Diesel Equipment	XBJ	N.C.	164.00	164.00
With B3J Diesel Equipment	XBJ	N.C.	108.00	108.00
K1 Series only	XBJ	N.C.	34.00	34.00
Rear				
C1 Series only				
Without B3J Diesel Equipment	YBJ	N.C.	154.00	164.00
With B3J Diesel Equipment	YBJ	N.C.	108.00	108.00
K1 Series only	YBJ	N.C.	34.00	34.00
Spare				
C1 Series only				
Without B3J Diesel Equipment	ZBJ	N.C.	82.00	82.00
With B3J Diesel Equipment	ZBJ	N.C.	54.00	54.00
K1 Series only	ZBJ	N.C.	17.00	17.00
<i>P235/75R15 Highway Steel Belted Radial Ply White Lettered</i> (Maximum Capacity 1843-lbs)				
Front				
C1 Series only				
Without B3J Diesel Equipment	XWV	N.C.	176.00	176.00
With B3J Diesel Equipment	XWV	N.C.	120.00	120.00
Rear				
C1 Series only				
Without B3J Diesel Equipment	YWV	N.C.	176.00	176.00
With B3J Diesel Equipment	YWV	N.C.	120.00	120.00
Spare				
C1 Series only				
Without B3J Diesel Equipment	ZWV	N.C.	88.00	88.00
With B3J Diesel Equipment	ZWV	N.C.	60.00	60.00
<i>P235/75R15 On-Off Road Steel Belted Radial Ply White Lettered</i> (Maximum Capacity 1843-lbs)				
K1 Series only				
Front	XEB	N.C.	66.00	66.00
Rear	YEB	N.C.	66.00	66.00
Spare	ZEB	N.C.	33.00	33.00

(a) D & H Charges on vehicle and optional equipment include reimbursement to ordering Division for any tax that it has paid, incurred or agreed to pay thereon.
 ◊ State and local taxes not included.

C-K PICKUP

OPTIONS AND ACCESSORIES WHEN INSTALLED BY GENERAL MOTORS

Prices shown are effective for vehicles produced on and after February 13, 1984

Description	Option Number	Factory D&H(a)	List Price	Mfr's Suggested Retail Price ◇
Tires: (Continued)				
L860-15/B Highway Rayon Belted Radial Ply Wheel				
(Maximum Capacity 1790-lbs)				
C10703 only. Available only when N67 or PA6 wheels are specified.				
Front				
Without B3J Diesel Equipment	XTS	N.C.	270.00	270.00
With B3J Diesel Equipment	XTS	N.C.	214.00	214.00
Rear				
Without B3J Diesel Equipment	YTS	N.C.	270.00	270.00
With B3J Diesel Equipment	YTS	N.C.	214.00	214.00
Spare				
Without B3J	ZTS	N.C.	135.00	135.00
With B3J Diesel Equipment	ZTS	N.C.	107.00	107.00
10R/15LT/B On-Off Road Steel Belted Radial Ply Wheel				
(Maximum Capacity 1780-lbs)				
K1 Series only. Available only when N67 or PA6 wheels are specified.				
Front	XXM	2.16	176.00	178.16
Rear	YXM	2.16	176.00	178.16
Spare	ZXM	1.08	88.00	89.08
10R/15LT/B On-Off Road Steel Belted Radial Ply Wheel				
(Maximum Capacity 1780-lbs)				
K1 Series only. Available only when N67 or PA6 wheels are specified.				
Front	XXN	2.16	238.00	240.16
Rear	YXN	2.16	238.00	240.16
Spare	ZXN	1.08	119.00	120.08
31 x 10.50R/15LTB On-Off Road Steel Belted Radial Ply Wheel				
(Maximum Capacity 1775-lbs)				
K1 Series only. Available only when N67 on PA6 wheels are specified.				
Front	XUY	2.16	176.00	178.16
Rear	YUY	2.16	176.00	178.16
Spare	ZUY	1.08	88.00	89.08
31 x 10.50R/15LTB On-Off Road Steel Belted Radial Ply Wheel				
(Maximum Capacity 1775-lbs)				
K1 Series only. Available only when N67 or PA6 wheels are specified.				
Front	XUZ	2.16	238.00	240.16
Rear	YUZ	2.16	238.00	240.16
Spare	ZUZ	1.08	119.00	120.08
7.50R16/D Highway Steel Belted Radial Ply Wheel				
(Maximum Capacity 2440-lbs). Not available when C6P H.D. Chassis is specified. Regular Cab only				
Front	XWY	.76	(-68.00)	(-67.24)
Rear	YWY	.76	(-68.00)	(-67.24)
Spare	ZWY	.43	276.00	276.43
7.50R16/D On-Off Road Steel Belted Radial Ply Wheel				
(Maximum Capacity 2440-lbs). Not available when C6P H.D. Chassis is specified. Regular Cab only				
Front. K2 Series only	XWX	2.08	(-10.00)	(-7.92)
Rear	YWX	2.08	(-10.00)	(-7.92)
Spare	ZWX	1.09	305.00	306.09
LT215/85R16-C Highway Steel Belted Radial Ply Wheel				
(Maximum Capacity each. Front or Single Rear 1940-lbs. Dual Rear 1764-lbs). Not available on C-K2 Regular Cab or C6P H.D. Chassis is specified.				
Front.				
C-K2 Regular Cab only. (Standard)	XYJ		NO ADDITIONAL CHARGE	
C3 Series only. Requires R05 Dual Rear	XYJ		(-1.80)	(-62.00)
Rear				
C-K2 Regular Cab only (Standard)	YYJ		NO ADDITIONAL CHARGE	
C3 Regular Cab only. Requires R05 Dual	YYJ		(-1.84)	494.00
Spare				
C-K2 Regular Cab only	ZYJ	.05	310.00	310.05
C3 Regular Cab only	ZYJ	.05	321.00	321.05

(a) D & H Charges on vehicle and optional equipment are not reimbursed to ordering Division for any tax that it has paid, incurred or agreed to pay thereon.
 ◇ State and local taxes not included.

C-K PICKUP

OPTIONS AND ACCESSORIES WHEN INSTALLED BY GENERAL MOTORS

Prices shown are effective with vehicles produced on and after February 13, 1984

Description	Option Number	Factory D&H(s)	List Price	Mfr's Suggested Retail Price [◇]
Tires: (Continued)				
LT215/85R16-D Highway Steel Belted Radial Ply Blackwall (Maximum Capacity Front or Single Rear 2315-lbs). (Dual Rear 2105-lbs). Not available C-K2 Regular Cab when C6P H.D. Chassis is specified.				
Front				
C-K2 Regular Cab only	XYK	.10	32.00	32.10
C-K3 Series only. Requires R05 Dual Rear Wheels	XYK	(-1.70)	(-30.00)	(-31.70)
Rear				
C-K2 Regular Cab only	YYK	.10	32.00	32.10
C-K3 Series only. Requires R05 Dual Rear Wheels	YYK	(-1.64)	558.00	556.36
Spare				
C-K2 Regular Cab	ZYK	.10	326.00	326.10
C-K3 Series only. Regular R05 Dual Rear Wheels	ZYK	.10	337.00	337.10
LT215/85R16-D On-Off Road Steel Belted Radial Ply Blackwall (Maximum Capacity Front or Single Rear 2315-lbs). (Dual Rear 2105-lbs) Not available C-K2 Regular Cab when C6P H.D. Chassis is specified.				
Front				
K2 Series only	XYL	.46	86.00	86.46
K3 Series only. Requires R05 Dual Rear Wheels	XYL	(-1.34)	24.00	22.66
Rear				
C-K2 Regular Cab only	YYL	.46	86.00	86.46
C-K3 Series only. Requires R05 Dual Rear Wheels	YYL	(-.92)	666.00	665.08
Spare				
C-K2 Regular Cab only	ZYL	.28	353.00	353.28
C-K3 Series only. Requires R05 Dual Rear Wheels	ZYL	.28	364.00	364.28
LT235/85R16-D Highway Steel Belted Radial Ply Blackwall (Maximum Capacity 2623-lbs).				
Front				
C-K2 Regular Cab without C6P H.D. Chassis	XYM	1.80	84.00	85.80
C-K2 Regular Cab with C6P H.D. Chassis or C20943 Bonus and Crew Cab. (Standard)	XYM	NO ADDITIONAL CHARGE		
C-K3 Series only. (Standard)	XYM	NO ADDITIONAL CHARGE		
Rear. C-K2 Regular Cab only. Not available when C6P H.D. Chassis is specified	YYM	1.80	84.00	85.80
Spare. C-K2 Regular Cab only. Not available when C6P H.D. Chassis is specified.	ZYM	.95	352.00	352.95
LT235/85R16-E On-Off Road Steel Belted Radial Ply Blackwall (Maximum Capacity 3042-lbs). C-K2 Regular Cab available only when C6P H.D. Chassis is specified. K3 Series not available when R05 Dual Rear Wheels are specified.				
Front. K2-3 Series only	XYT	.56	86.00	86.56
Rear. C-K2 or K3 Series only	YYT	.42	54.00	54.42
Spare. C-K2 or K3 Series only	ZYT	1.23	395.00	396.23
LT235/85R16-E Steel Belted Radial Ply Blackwall (Maximum Capacity 3042-lbs). Available only when C6P H.D. Chassis is specified on C2 Regular Cab. C-K3 not available when R05 Dual Rear Wheels are specified.				
Front				
C2 or C-K3 Series only	XYN	.14	32.00	32.14
K2 Series only				
Without C6P H.D. Chassis	XYN	1.94	116.00	117.94
With C6P H.D. Chassis	XYN	.14	32.00	32.14
Rear				
C2 or C-K3 Series only (Standard)	YYN	NO ADDITIONAL CHARGE		
K2 Series only				
Without C6P H.D. Chassis	YYN	1.84	116.00	117.84
With C6P H.D. Chassis. (Standard)	YYN	NO ADDITIONAL CHARGE		
Spare. C-K2-3 Series only	ZYN	1.02	368.00	369.02
TUBE-TYPE				
7.50-16/C Highway Nylon Blackwall (Maximum Capacity each. Front 2080-lbs) (Dual Rear 1815-lbs). Available only when R05 Dual Rear Wheels are specified.				
Front. C3 Series	XPB	(-1.90)	(-284.00)	(-285.90)
Rear. C3 Regular Cab only	YPB	(-2.04)	50.00	47.96
Spare. C3 Regular Cab only	ZPB	N.C.	210.00	210.00

(a) D & H Charges on vehicle and optional equipment include reimbursement to ordering Division for any tax that it has paid, incurred or agreed to pay thereon.
[◇] State and local taxes not included.

C-K PICKUP

OPTIONS AND ACCESSORIES WHEN INSTALLED BY GENERAL MOTORS

Prices shown are effective with vehicles produced on and after February 13, 1984

Description	Option Number	Factory D&H(a)	List Price	Mfr's Suggested Retail Price ^o
Tires: (Continued)				
7.50-16/C On-Off Road Nylon Ply Blackwall (Maximum Capacity each. Dual Rear 1815-lbs). Available only when R05 Dual Rear Wheels are specified. C3 Regular Cab only				
Rear	YPC	(-2.04)	162.00	159.98
Spare	ZPC	N.C.	238.00	238.00
7.50-16/D Highway Nylon Ply Blackwall (Maximum Capacity each. Front 2440-lbs) (Dual Rear 2140-lbs). Available only when R05 Dual Rear Wheels are specified.				
Front	XPF	(-1.90)	(-252.00)	(-253.90)
Rear	YPF	(-2.04)	114.00	111.96
Spare	ZPF	N.C.	228.00	228.00
7.50-16/D On-Off Road Nylon Ply Blackwall (Maximum Capacity each. Front 2440-lbs) (Dual Rear 2140-lbs). Available only when R05 Dual Rear Wheels are specified.				
Front. K3 Series only	XPG	(-1.82)	(-194.00)	(-195.82)
Rear. C-K Series only	YPG	(-1.88)	230.00	228.12
Spare	ZPG	.04	255.00	255.04

OTHER OPTIONS

Air Cleaner, Pre-Cleaner: Not available when LE3 4.1 Liter or L25 4.8 Liter Engine is specified	K46	N.A.	41.00	41.00
Air Conditioning: All-Weather. Not available when V10 Cold-Climate Package is specified. Includes extra cooling. Without B3J Diesel Equipment. Includes K81 66-Amp Generator	C60	N.A.	730.00	730.00
With B3J Diesel Equipment	C60	N.A.	670.00	670.00
Appearance, Deluxe Front: Includes dark argent grille with bright trim and dual rectangular headlamps. Included when YE8 is specified	V22	N.A.	106.00	106.00
Batteries: 12-Volt 515 Cold Cranking Amps Delco Freedom. Not available when B3J Diesel Equipment is specified. Auxiliary. Not available on C-K1 Series	TP2	N.A.	122.00	122.00
Heavy-Duty. Included when V10 Cold-Climate Package is specified	UA1	N.A.	50.00	50.00
Brakes:				
Power. C1 Series only. Not available when B3J Diesel Equipment is specified	J50	N.A.	92.00	92.00
Heavy-Duty Power. Standard on K1 Series. C2 Bonus and Crew Cab and C-K3 Series. Included when C6P H.D. Chassis is specified.				
Without B3J Diesel Equipment.				
C1 Series only	J55	N.A.	168.00	168.00
C2 Regular Cab only. Available only when G50 H.D. or G51 Extra Capacity Rear Springs are specified	J55	N.A.	101.00	101.00
K2 Regular Cab only	J55	N.A.	101.00	101.00
With B3J Diesel Equipment				
C1 Series	J55	N.A.	76.00	76.00
C2 Regular Cab only. Available only when G50 H.D. or G51 Extra Capacity Rear Springs are specified	J55	N.A.	101.00	101.00
K2 Regular Cab	J55	N.A.	101.00	101.00
Bumper Equipment:				
Bumpers, Chromed.				
Rear	VF1	N.A.	100.00	100.00
Rear Step, Fleetside/Wideside only	V42	N.A.	183.00	183.00
Bumpers, Painted. Rear Step	V43	N.A.	115.00	115.00
Guards, Front Bumper. Chromed	V31	N.A.	40.00	40.00

(a) D & H Charges on vehicle and optional equipment include reimbursement to ordering Division for any tax that it has paid, incurred or agreed to pay thereon.
^o State and local taxes not included.

C-K PICKUP

OPTIONS AND ACCESSORIES WHEN INSTALLED BY GENERAL MOTORS

Prices shown are effective with vehicles produced on and after February 13, 1984

Description	Option Number	Factory D&H(a)	List Price	Mfr's Suggested Retail Price ◊
OTHER OPTIONS				
Camper Chassis Equipment: Basic Camper Group. C-K3 Series only. Available only when V8 engine is specified. Includes camper body wiring harness.				
C2 Series also includes F58 H.D. Front Stabilizer.				
Regular Cab only. Available only when C6P H.D. Chassis is specified	Z81	N.A.	64.00	64.00
Bonus Cab Crew Cab only	Z81	N.A.	64.00	64.00
K2 Series. Available only when C6P H.D. Chassis is specified. Includes F60 H.D. Front Springs	Z81	N.A.	103.00	103.00
C3 Series also includes F58 H.D. Front Stabilizer.				
Without Dual Rear Wheels	Z81	N.A.	99.00	99.00
With Dual Rear Wheels. 10,000-lb GVW. Includes G60 Main and Auxiliary Rear Springs and rear stabilizer	Z81	N.A.	234.00	234.00
K3 Series. Available only when R05 Dual Rear Wheels are specified	Z81	N.A.	46.00	46.00
Carriers, Wheel and Tire: Available only when spare tire is specified.				
Glide-Out	P11	N.A.	40.00	40.00
Side Mounted. Fleetside/Wideside only	P13	N.A.	28.00	28.00
Clock: Quartz.				
Without includes Z53 Voltmeter, Temperature and Oil Pressure	U35	N.A.	76.00	76.00
With YE9	U35	N.A.	38.00	38.00
Cold-Climate Package: Not available when C60 Air Conditioning or B3J Diesel Equipment is specified. Includes special insulation, K81 66-Amp Generator, special heater and defroster, Engine Block Heater, anti-freeze protection to -32 degrees, and A1 H.D. Battery.				
Without Dual Rear Wheels.	V10	N.A.	192.00	192.00
With YE9	V10	N.A.	180.00	180.00
C-K3 Series R05 Dual Rear Wheels.	V10	N.A.	132.00	132.00
With YE9	V10	N.A.	120.00	120.00
Commercial Chassis Equipment, Special: C3 Fleetside/Wideside only. Available only when R05 Dual Rear Wheels are specified. Not available when L25 4.8 Liter Engine or Z81 Commercial Special is specified. Includes F58 H.D. Front Stabilizer, Stabilizer and G60 Main and Auxiliary Rear Springs				
	Z76	N.A.	188.00	188.00
Coolers:				
Engine Oil: Not available when LE3 4.1 Liter, L25 4.8 Liter Engine or B3J Diesel Equipment is specified				
	KC4	N.A.	116.00	116.00
Transmission: Heavy-Duty. Not available when LE3 4.1 Liter or L25 4.8 Liter Engine is specified. Available only when MX0 or MXO Automatic Transmission is specified.				
C-K1 Series also available only when MXO Automatic Transmission and C60 Air Conditioning or VO1 H.D. Radiator and B3J Diesel Equipment is specified	V02	N.A.	57.00	57.00
Cooling System: Radiator, Heavy-Duty. Not available when C60 Air Conditioning or B3J Diesel Equipment is specified.				
C-K1 Series	V01	N.A.	51.00	51.00
C-K2-3 Series only. Not available when MXO or MX1 Automatic Transmission is specified	V01	N.A.	51.00	51.00
Decor Package, Value: Not available on Bonus Cab, Crew Cab Wideside Models. Not available when YE9, R05 Dual Rear Wheels, V22 Deluxe Front Appearance, Whitewall Tires, B84 or B85 Body Side Moldings. Available only when ZY1 Solid Black and Blackwall or White Lettered tires are specified. Includes blacked painted radiator grille and headlamp and special body stripes located between body features on the front fenders, pickup box and will extend across tailgate				
C-K1 Series includes N67 Rally Wheels	YJ6	N.A.	250.00	250.00
C-K2-3 Series	YJ6	N.A.	141.00	141.00

(a) D & H Charge on vehicle and optional equipment include reimbursement to ordering Division for any tax that it has paid, incurred or agreed to pay thereon.
 ◊ State and local taxes not included.

C-K PICKUP

OPTIONS AND ACCESSORIES WHEN INSTALLED BY GENERAL MOTORS

Prices shown are effective with vehicles produced on and after February 13, 1984

Description	Option Number	Factory D&H(a)	List Price	MTR's Suggested Retail Price ^o
OTHER OPTIONS				
Door Lock System, Power: Included when ZQ2 Operating Convenience Package is specified				
Regular Cab only	AU3	N.A.	130.00	130.00
Bonus and Crew Cab only	AU3	N.A.	190.00	190.00
Floor Covering: Mats, Color-Keyed Front Floor. Available only when YE9 is specified				
	B32	N.A.	14.00	14.00
Gages: Voltmeter, Temperature and Oil Pressure. Included when YE9 or U25 Electric Clock is specified				
	Z53	N.A.	38.00	38.00
Generator: 65-Amp Delcotron. Included when B3J Diesel Equipment, C60 Air Conditioning, V10 Cold-Climate Package or R05 Dual Rear Wheels are specified				
	K61	N.A.	60.00	60.00
Glass: Tinted. All Windows.				
Regular Cab only	A01	N.A.	45.00	45.00
Bonus Cab or Crew Cab only	A01	N.A.	54.00	54.00
Headlamps: Halogen Hi-Beam. Available only when V22 Deluxe Front Appearance Package or YE9 is specified				
	TT5	N.A.	18.00	18.00
Heaters:				
Engine Block. 600 Watts, 120 Volts. Not available when B3J Diesel Equipment is specified. Included when V10 Cold-Climate Package is specified				
	K05	N.A.	31.00	31.00
Heavy Duty. Front. Available only when B3J Diesel Equipment is specified. Not available when C60 Air Conditioning is specified				
	C42	N.A.	42.00	42.00
Lamps:				
Cargo.				
Without Z62 or YE9. Includes C91 Dome Lamp	UF2	N.A.	58.00	58.00
With Z62 or YE9	UF2	N.A.	33.00	33.00
Dome. Included when Z62, YE9 or UF2 Cargo Lamp is specified. Includes door actuated switches and bright lamp bezels				
	C91	N.A.	25.00	25.00
Roof Marker. One. C-K2-3 Series only. Without R05 Dual Rear Wheels, available only when NA6 Standard or NA6 High Altitude Emission Equipment is specified. Included when R05 Dual Rear Wheels are specified				
	U01	N.A.	48.00	48.00
Lighter, Cigarette: Included when Z62 or YE9 is specified				
	U37	N.A.	29.00	29.00
Mirrors, Exterior: LH and RH.				
Below-Eye-Line Type. 9" x 6.5".				
Painted	D44	N.A.	48.00	48.00
Stainless Steel	D45	N.A.	78.00	78.00
Camper Type. Stainless steel. 7.5" x 10.5". Adjustable arm feature to provide field of vision for vehicles to 98" wide. Shipped loose for dealer installation				
	DF2	N.A.	91.00	91.00
Senior West Coast Type. Painted. C-K3 Series only. Shipped loose for dealer installation				
	DG5	N.A.	63.00	63.00
Moldings: Fletside/Wideside only.				
Body Side Black. Bright with black insert. Not available when YE9, R05 Dual Rear Wheels, B85 Bright Body Side Moldings or YG3 Deluxe Molding Package is specified. Included when YG1 Custom Molding Package, Z62, ZY3 Special Two-Tone Paint, ZY4 Deluxe Two-Tone Paint or ZY5 Exterior Decor Package is specified. Includes lower side and rear moldings of black plastic with bright trim				
	B84	N.A.	111.00	111.00
Body Side Bright. Not available when B84 Black Body Side Moldings, YG1 Custom Molding Package, R05 Dual Rear Wheels, ZY3 Special Two-Tone Paint, ZY4 Deluxe Two-Tone Paint or ZY5 Exterior Decor Package is specified. Included when YG3 Deluxe Molding Package or YE9 is specified. Includes bright plastic body side rear lower moldings with black paint trim plus bright trim for front side marker lights and taillights				
Without Z62	B85	N.A.	139.00	139.00
With Z62	B85	N.A.	15.00	15.00

(a) D & H Charges on vehicle and optional equipment include reimbursement to ordering Division for any tax that it has paid, incurred or agreed to pay thereon.
^o State and local taxes not included.

C-K PICKUP

OPTIONS AND ACCESSORIES WHEN INSTALLED BY GENERAL MOTORS

Prices shown are effective with vehicles produced on and after February 13, 1984

Description	Option Number	Factory D&H(s)	List Price	Mfr's Suggested Retail Price ◊
OTHER OPTIONS				
Moldings: (Continued)				
<i>Custom Package. Fleetside/Windows only. Not available when YG3 Deluxe Molding Package, YE9 or R05 Dual Rear Wheels are specified. Includes ZY3 Special Two-Tone Paint, ZY4 Deluxe Two-Tone Paint or ZY5 Exterior Decor Package is specified. Includes opening molding, B84 Black Body Side Moldings, bright trim for front side marker lamps and taillights.</i>				
Without Z62	YG1	N.A.	152.00	152.00
With Z62	YG1	N.A.	28.00	28.00
<i>Deluxe Package. Fleetside/Windows only. Not available when YG1 Custom Molding Package, R05 Dual Rear Wheels are specified. Includes when YE9 is specified. Includes bright trim for front side marker lamps and taillights, B85 Bright Body Side Moldings and wheel opening moldings.</i>				
Without Z62, ZY3 Special Two-Tone Paint, ZY4 Deluxe Two-Tone Paint or ZY5 Exterior Decor Package	YG3	N.A.	167.00	167.00
With Z62	YG3	N.A.	43.00	43.00
With ZY3 Special Two-Tone Paint, ZY4 Deluxe Two-Tone Paint or ZY5 Exterior Decor Package	YG3	N.A.	15.00	15.00
Guards, Door Edge.				
Regular Cab only	B93	N.A.	16.00	16.00
Bonus Cab or Crew Cab only	B93	N.A.	21.00	21.00
Operating Convenience Package: Includes AU3 Power Door Locks and A31 Power Windows				
Regular Cab only	ZQ2	N.A.	310.00	310.00
bonus and Crew Cab only	ZQ2	N.A.	466.00	466.00
Preliminary Price Information	B3W	N.A.	N.A.	N.A.
Radio Equipment:				
AM Radio	U63	N.A.	112.00	112.00
AM/FM Radio	U69	N.A.	171.00	171.00
AM/FM Stereo Radio	U58	N.A.	198.00	198.00
AM/FM Stereo Radio with Stereo Cassette Tape	UN3	N.A.	298.00	298.00
Windshield Antenna. Includes U63, U69, U58 or UN3 Radio is specified.	U78	N.A.	31.00	31.00
Rails, Pickup Box Side	D73	N.A.	91.00	91.00
Shield, Transfer Case: K12 Series only.	NY7	N.A.	40.00	40.00
Shock Absorbers: Heavy-Duty Front and Rear. Standard on C2 Bonus and Crew Cab and C3 Series. Included on C2 Series when C6P H.D. Chassis is specified. Not available K1-2 Series.				
.....	F51	N.A.	32.00	32.00
Shocks, Front Quad: K12 Regular Cab only. Includes dual left and right hand shock absorbers on front, heavy duty shock absorbers on rear and adjustable nose bumper to limit axle windup				
K1 Series only.	Z75	N.A.	123.00	123.00
K2 Series only.	Z75	N.A.	123.00	123.00
Without C6P H.D. Chassis	Z75	N.A.	91.00	91.00
With C6P H.D. Chassis	Z75	N.A.	91.00	91.00
Speed Control, Electronic: I1 Series without B3J Diesel Equipment is available on J50 or J55 H.D. Power Brakes and MM3 3-Speed, MM4 4-Speed or MX0 Automatic Transmission are specified. C3 Series not available with MM4 or MM7 4-Speed Transmission unless L25 4.8 Liter Engine or B3J Diesel Equipment is specified				
.....	K34	N.A.	185.00	185.00
Springs:				
<i>Front, Heavy-Duty. Not available on C2 Bonus and Crew Cab and C-K3 Series.</i>				
Capacity 1625-lb each. C1 Series not available when J55 HD Power Brakes or B3J Diesel Equipment is not specified.	F80	N.A.	14.00	14.00

(a) D & H Charges on vehicle and optional equipment include reimbursement to ordering Division for any tax that it has paid, incurred or agreed to pay thereon.
 ◊ State and local taxes not included.

C-K PICKUP

OPTIONS AND ACCESSORIES WHEN INSTALLED BY GENERAL MOTORS

Options shown are effective with vehicles produced on and after February 13, 1984

Description	Option Number	Factory D&H(s)	List Price	GM's Suggested Retail Price ^o
OTHER OPTIONS				
Springs: (Continued)				
Capacity 1700-lb each. C1 Series only. Included when B3J Diesel Equipment is specified. Available only when J55 H.D. Power Windows are specified	F60	N.A.	14.00	14.00
Capacity 1900-lb each. C2 Series only. Included when C6P H.D. Chassis or B3J Diesel Equipment is specified	F60	N.A.	14.00	14.00
Capacity 2250-lb each.				
K1 Series only. Includes H.D. front and rear shock absorbers. Recommended for snowplow type usage only.				
Without Z75 Front Quad Shocks	F60	N.A.	89.00	89.00
With Z75 Front Quad Shocks	F60	N.A.	57.00	57.00
K2 Series only. Included when Z81 Camper Special Chassis Equipment is specified. Includes H.D. front and rear shock absorbers when C6P H.D. Chassis is not specified.				
Without Z75 Front Quad Shocks or C6P H.D. Chassis	F60	N.A.	89.00	89.00
With Z75 Front Quad Shocks or C6P H.D. Chassis	F60	N.A.	57.00	57.00
Rear, Heavy-Duty. Not available on C6P H.D. Chassis, C2 Bonus and Crew Cab, or K1-2-3 Series.				
Capacity 1750-lb each. C1 Series only.	G50	N.A.	55.00	55.00
Capacity 2600-lb each, two-stage. C2 Regular Cab only. Not available with C6P H.D. Chassis or Z81 Camper Special Chassis Equipment is specified	G50	N.A.	55.00	55.00
Rear, Extra Capacity.				
Capacity 2000-lb each. C1 Series only	G51	N.A.	69.00	69.00
Capacity 3000-lb each. C2 Series only. Standard on C2 Bonus and Crew Cab, or C-K3 Series only. Not available on K2 Series. Included when C6P H.D. Chassis is specified	G51	N.A.	69.00	69.00
Rear, Main and Auxiliary. Capacity 3750-lb each. C-K3 Series only. Included when Z81 Camper Special Chassis Equipment is specified. R05 Dual Rear Wheels or Z78 Commercial Chassis Equipment on C3 Series. Also included when R05 Dual Rear Wheels are specified on K3 Series.	G60	N.A.	94.00	94.00
Stabilizer Bars:				
Front. 1" diameter. Standard on C2 Bonus or Crew Cab. Included when C6P H.D. Chassis is specified on C2 Series. Not available on K1-2-3 Series or when Z78 Commercial Chassis Equipment or Z81 Camper Special Chassis Equipment is specified	F59	N.A.	35.00	35.00
Front, Heavy-Duty. 1.25" diameter. C2-3 Series only. Standard on K1-2-3 Series. Included when Z78 Commercial Chassis Equipment or Z81 Camper Special Chassis Equipment is specified				
Without C6P H.D. Chassis	F58	N.A.	53.00	53.00
With C6P H.D. Chassis or C2 Bonus or Crew Cab	F58	N.A.	18.00	18.00
Steering:				
Power. Standard on K1-2-3 Series. Included when B3J Diesel Equipment is specified	N41	N.A.	252.00	252.00
Power, Not Desired. C1-2-3 Series only. Not available when B3J Diesel Equipment is specified	N51	NO ADDITIONAL CHARGE		
Steering Wheel: Standard. Not available when MM3 3-Speed Manual Transmission is specified	N33	N.A.	110.00	110.00
Tank, Fuel: Auxiliary. 40 Gallon Mounted.				
C-K1-2 Series only				
Without B3J Diesel Equipment. Provides two fuel tanks of approximately 16 gallons per tank	NL2	N.A.	250.00	250.00
With B3J Diesel Equipment				
C-K10703. Provides two fuel tanks of approximately 16-gallon per tank	NL2	N.A.	262.00	262.00
C-K10903. Provides two fuel tanks of approximately 20-gallon per tank	NL2	N.A.	262.00	262.00
C-K2,3 Series only. Provides two fuel tanks of approximately 20-gallon per tank				
Without B3J Diesel Equipment	NL2	N.A.	250.00	250.00
With B3J Diesel Equipment	NL2	N.A.	262.00	262.00

(a) D & H Charges on vehicle and optional equipment include reimbursement to ordering Division for any tax that it has paid, incurred or agreed to pay thereon.
 o State and local taxes excluded.

C-K PICKUP

OPTIONS AND ACCESSORIES WHEN INSTALLED BY GENERAL MOTORS

Prices shown are effective with vehicles produced on and after February 13, 1984

Description	Option Number	Factory D&H(s)	List Price	Mfr's Suggested Retail Price ^o
OTHER OPTIONS				
Towing Device: Two front towing hooks. K1-2-3 Series only.	V76	N.A.	35.00	35.00
Wheel Trim: Bright Metal.				
Wheel Covers.				
C-K1 Series only.	P01	N.A.	39.00	39.00
C3 Series only. Available only when R05 Dual Rear Wheels and 7.50-16 Tires are specified.	P01	N.A.	48.00	48.00
Wheel Covers, Special. C-K2 and C3 Series only. Not available when R05 Dual Rear Wheels are specified.	PA1	N.A.	114.00	114.00
Wheels: C-K1 Series only.				
Rally. Includes special hub caps and trim rings. Included when YJ8 Rally Master Decor is specified.				
Without P225 or P235 Tires. Wheel size is 15" x 7"	N67	N.A.	109.00	109.00
With P225 or P235 Tires. Wheel size is 15" x 8"	N67	N.A.	109.00	109.00
Styled. Includes special hub caps. Four wheels only.				
Without P225 or P235 Tires. Wheel size is 15" x 7"	PA6	N.A.	168.00	168.00
With P225 or P235 Tires. Wheel size is 15" x 8"	PA6	N.A.	168.00	168.00
Wheels, Dual Rear: C-K3 Fleetside/Wideside only. Not available when L25 4.8 Liter Engine is specified. Includes K81 66-Amp Generator, plastic rear fender extensions with side marker lamps located on front and rear sides and dual rear chassis provisions.				
C3 Series only. Available only when Z76 Special Commercial Chassis Equipment or Z81 Camper Special Chassis Equipment is specified. MX1 Automatic Transmission available only when V02 Transmission Oil Cooler is specified. Includes U01 Roof Marker Lamps.				
Without C60 Air Conditioning or B3J Diesel Equipment.				
Regular Cab only.	R05	N.A.	715.00	715.00
Bonus Cab or Crew Cab only.	R05	N.A.	715.00	715.00
With C60 Air Conditioning or B3J Diesel Equipment.				
Regular Cab only.	R05	N.A.	655.00	655.00
Bonus Cab or Crew Cab only.	R05	N.A.	655.00	655.00
K3 Series only. MX1 Automatic Transmission available only when V02 Transmission Oil Cooler is specified. Also includes G60 Main and Auxiliary Springs				
Without C60 Air Conditioning or B3J Diesel Equipment	R05	N.A.	809.00	809.00
With C60 Air Conditioning or B3J Diesel Equipment .	R05	N.A.	749.00	749.00
Wheels, Single Rear: C-K3 Fleetside/Wideside only. Not available when R05 Dual Rear Wheels are specified.	R04	NO ADDITIONAL CHARGE		
Windows:				
Power. Included when ZQ2 Operating Convenience Package is specified				
Regular Cab only.	A31	N.A.	180.00	180.00
Bonus and Crew Cab only.	A31	N.A.	276.00	276.00
Sliding Rear. (Note: If A01 Tinted Glass is specified, sliding window will remain clear.)	A28	N.A.	104.00	104.00
Windshield Wiper System: Intermittent. Not available when MM3 3-Speed Manual Transmission is specified.	CD4	N.A.	50.00	50.00

(a) D & H Charges on vehicle and optional equipment include reimbursement to ordering Division for any tax that it has paid, incurred or agreed to pay thereon.
^o State and local taxes not included.

NOTES

1 1 1



1 1 1

1 1 1

1 1 1

C/K PICKUP

**CAB & BODY FEATURES
CAB CONSTRUCTION
CAB DIMENSIONS
COLOR & TRIM CHARTS
TWO-TONES**

C/K PICKUP

CUSTOM DELUXE/SIERRA FEATURES—STANDARD MODEL

The Custom Deluxe/Sierra standard models include the following items as standard equipment

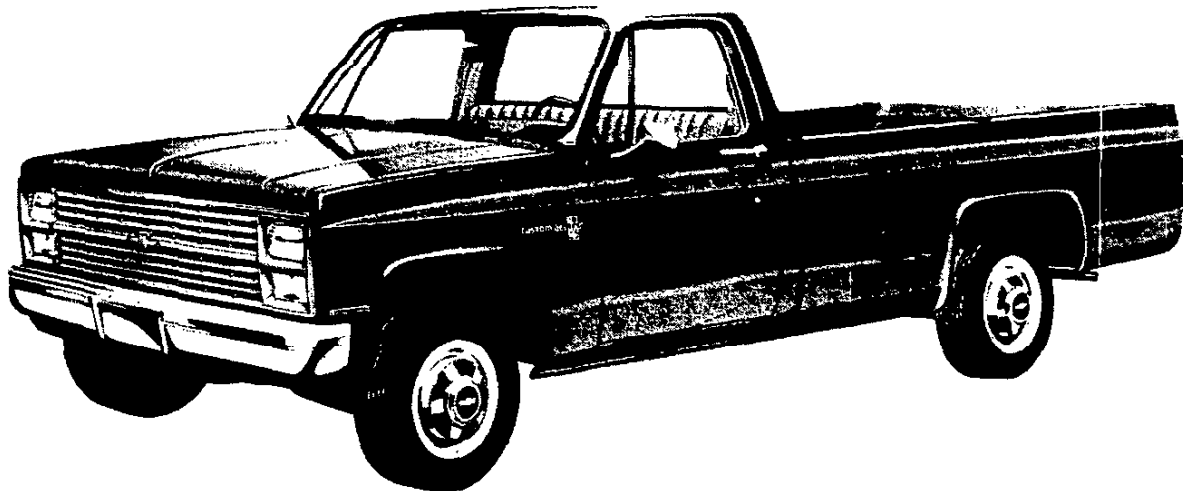

EXTERIOR

- **Bumper:** Front; chromed
- **Color:** See Interior and Exterior Color Selection Chart
- **Grille and Headlamp Bezels:** Molded plastic; painted argent; integral Chevrolet emblem/GMC letters at center of grille
- **Horn:** Single, electric, low-note
- **Hub Caps:** Bright metal with black trim (single rear wheel models only)
- **Keys:** Two-key system; with separate keys for ignition switch and door locks
- **Lettering, "Chevrolet/GMC" Tailgate:** White decal except black with Frost White body color
- **Lights:**
 - Backup lamps: Two rear (integral with taillamps)
 - Clearance and identification lamps (K3 Series models only):
 - Five front (on roof); Five rear (on tailgate)
 - Combination parking/direction/hazard: Two front
 - Combination tail/stop/direction/hazard: Two rear
 - Headlamps: Two, rectangular
 - License plate lamp: Single rear
- **Side marker lamps with reflectors:** two front; two rear (integral with taillamps)
- **Mirrors:** RH and LH fixed arm with adjustable 5-7/16" wide x 4" high heads; chrome finish
- **Moldings:** Bright; drip molding over side doors; headlamp and grille outline moldings
- **Nameplates:** Bright "Custom Deluxe/Sierra" nameplates with series designation on front fenders near doors; bright "3 + 3" nameplates on Crew Cab models or "BONUS CAB" nameplates on Bonus Cab models on cab rear quarters at styling crease line
- **Pickup Box:** Steel floor on Fleetside/Wideside models and wood floor with steel skid strips on Stepside/Fenderside models; painted body color
- **Spare Tire Carrier:** Under frame in back (C-K1 Series models only)
- **Tools:** Mechanical jack and wheel wrench
- **Wheels:** Painted white
- **Windshield Wipers and Washers:** Electric, 2-speed wipers with bright finish on exposed metal portions; coordinated dual-nozzle washers



C/K PICKUP

CUSTOM DELUXE/SIERRA FEATURES—STANDARD MODEL

The Custom Deluxe/Sierra standard models include the following items as standard equipment

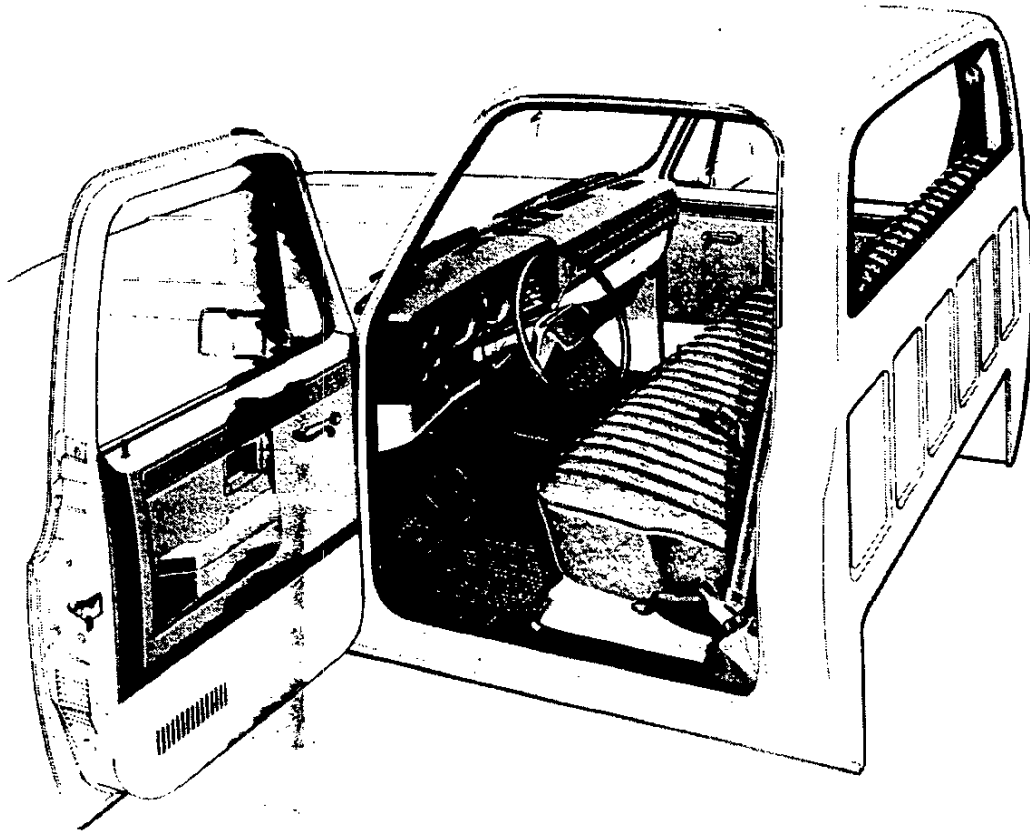

INTERIOR

- **Armrests:** RH and LH padded; integrated with door trim panels
- **Ashtrays:** In middle of instrument panel (all models) and in rear door trim panels (Crew Cabs and Bonus Cabs)
- **Coat Hooks:** RH (all models) and over rear doors (Crew Cabs and Bonus Cabs)
- **Colors:**
Painted areas: Same as exterior primary color choice
Interior trim: Coordinated with seat color choice
- **Door Sill Plates:** Door-opening protection and floor mat retention; full-length; black plastic for regular Cab front doors and bright metal for Bonus Cab and Crew Cab front and rear doors
- **Door Trim Panels:** Color-keyed, embossed molded plastic with integral armrests
- **Floor Covering:** Embossed black rubber mats
- **Heater and Defogger:** Deluxe-air
- **Hood Lock Release:** Handle located on LH side under instrument panel
- **Instrument Cluster Bezel:** Black crackle finish with bright trim
- **Instruments:**
Gages: Speedometer, odometer and fuel
Switches: Main, for control of exterior lights, instrument cluster lights, and cab interior lights; multi-function switch on steering column for direction signals by moving lever up or down (includes lane change position); wiper beams by pulling lever toward driver, windshield wiper by turning band marked "WIPER" toward or away from driver, and windshield washer by pushing in the lever toward center; ignition with key-in warning buzzer; hazard warning; cooling fan
Warning lights: Generator, oil pressure, engine temperature, seat belt, service-parking brake, direction/hazard signal, and high beam
- **Instrument Panel Control Knobs:** Soft black plastic (except heater and wiper-washer controls) with graphic identification
- **Instrument Panel Pad:** Color-keyed, energy-absorbing foam type with grained vinyl skin; has black crackle-finished applique on RH side with bright, black, and silver trim and bright "Custom Deluxe/Sierra" nameplate
- **Insulation and Sound Deadening Material:** Dash (firewall), under front seat at center, under front floor mat, under rear floor mat and under rear seat at center on Crew Cabs, under rear floor mat on Bonus Cabs (center portion only in rearmost area) and between double-walled roof panel of regular cabs. NOTE: Extra-thick insulation used for front portion of Crew Cab and Bonus Cab rear compartment
- **Lights:** Instrument cluster and cab interior lights
- **Mirror, Rearview:** 10" prismatic with soft vinyl rim
- **Seats:** Full-width, full depth foam bench-type with embossed grained all-vinyl trim; front (all models) and rear (Crew Cabs); includes folding backrest for regular cab seat and Crew Cab rear seat. Also available at extra cost: (1) dual-tone woven cloth/vinyl trim; or (2) all-vinyl leather grained trim. See Interior and Exterior Color Selection Chart for color and trim availability
- **Seat Belts:** Front (all models): non-detachable combination lap and shoulder belts for outboard positions with emergency-locking retractors and switch in driver's lap belt retractor for buzzer warning system; lap belt with manual adjustment for center position. Rear (Crew Cabs only): lap belts with emergency-locking retractors for outboard positions; lap belt with manual adjustment for center position. All seat belts are color-keyed with pushbutton type buckles
- **Steering Wheel and Column:** 16" black, soft plastic wheel with 2 spokes; black energy-absorbing steering column with anti-theft locking feature
- **Stowage Box:** In RH side of instrument panel; door has bright turn-type latch release
- **Sunshades:** RH and LH padded; color-keyed

C/K PICKUP

SCOTSDALE/HIGH SIERRA MODEL OPTION—RPO Z62 (FOR ALL MODELS)

This option includes all Custom Deluxe/Sierra standard model items plus the additions or substitutions listed below



Chevrolet model shown (GMC model available)

EXTERIOR

- **Bright Appearance Items:**
 - "Scottsdale/High Sierra" nameplates with series designation on front fenders
 - Body side and rear molding trim (Fleetside/Wideside models with single rear wheels only)
 - Front fender side marker lamp trim
 - Rear fender clearance lamp trim (Fleetside/Wideside models with dual rear wheels only)
 - Taillamp trim (Fleetside/Wideside only)
 - Windshield and rear window reveal moldings
- **Horn:** Additional, electric high-note
- **Moldings:** Black plastic body side and rear moldings with bright trim (Fleetside/Wideside models with single rear wheels only)

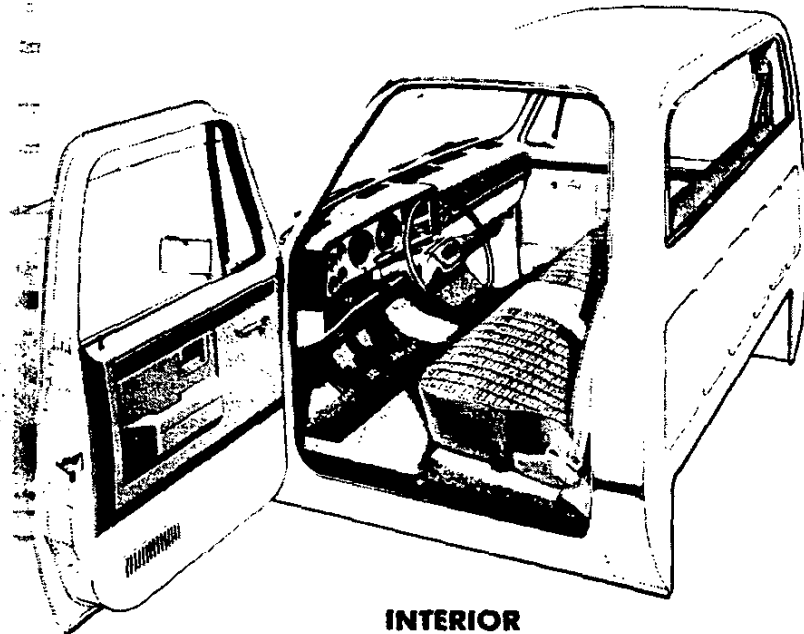

INTERIOR

- **Bright Appearance Items:**
 - "Scottsdale/High Sierra" nameplate on instrument panel pad
 - Dome lamp trim
 - Trim on instrument cluster bezel, instrument panel pad applique
 - Trim on door trim panels (regular cabs only)
- **Cigar Lighter:** Amber optic illuminated ashtray
- **Dome Lamp:** White trim
- **Dome and Interior Lamp Switches:** Front door-operated (dome and interior lamps also may be activated by main light switch)
- **Door Trim Panels:** Color-keyed embossed molded plastic, with black crackle-finished upper decorative inserts having a silver border (Regular Cabs only)
- **Floor Covering:** Color-keyed rubber mats (except Bonus Cab rear compartment mat)
- **Headliner:** Full-length mystic-colored, perforated molded cloth with fiberglass blanket backing; includes matching retainer moldings (Crew Cabs and Bonus Cabs only)
- **Insulation:** Under cowl panel, on Crew Cab and Bonus Cab headliner, and on cab back panel
- **Pillar Trim Panels:** Mystic molded plastic on windshield pillars and center door pillars (Crew Cabs and Bonus Cabs only)
- **Seats:** See Interior and Exterior Color Selection Chart for color and trim availability
 - Regular Cabs—choice of: 1) dual-tone woven cloth/vinyl trim; or 2) all-vinyl leather grained trim
 - Crew Cabs and Bonus Cabs—embossed grained all-vinyl trim standard. Also available at extra cost: 1) all-vinyl leather grained trim; or 2) cut pile velour cloth/vinyl trim

C/K PICKUP

SILVERADO/SIERRA CLASSIC MODEL OPTION—RPO YE9 (FOR REGULAR CAB MODELS)

This option includes all items in the Scottsdale/High Sierra model option plus the additions or substitutions listed below



GMC model shown (Chevrolet model available)

• **Bright Appearance Items:**

- "Silverado/Sierra Classic" nameplates with series designation on front fenders
- Chrome-trimmed grille and headlamp bezels (Chevrolet models only)
- Chevrolet emblem/GMC letters at grille center
- Cab back panel applique molding
- "Chevrolet/GMC letters" nameplate on tailgate applique panel (Fleetside/Wideside only)
- Bright applique panel fitted over central area of tailgate with

EXTERIOR

- black-trimmed decorative border (Fleetside/Wideside only)
- Body side and rear moldings with black paint trim (Fleetside/Wideside models with single rear wheels only)
- Wheel-opening lip moldings with black paint trim (Fleetside/Wideside models with single rear wheels only)

- **Cab-to-Fender Insulators**
- **Grille and Headlamp Bezel Paint:** Dark argent (Chevrolet); argent/dark argent (GMC)
- **Hood Insulator**
- **Special Headlamps:** Rectangular; dual RH and LH

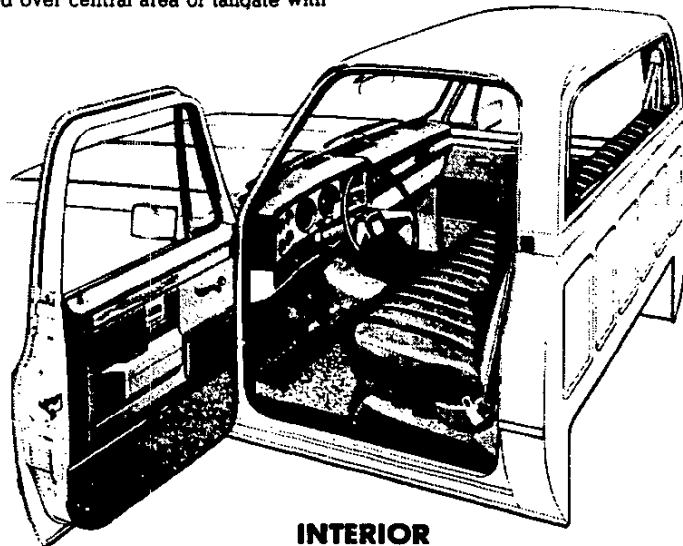

INTERIOR

• **Bright Appearance Items:**

- "Silverado/Sierra Classic" nameplate on instrument panel pad
- MM4 four-speed transmission shift lever (C1-2-3 models)
- Trim on horn button
- **Cowl Panel Trim:** Color-keyed molded plastic on entire surface of cowl side panels
- **Door Trim Panels:** Special color-keyed molded plastic with pewter-toned brush-finished upper decorative inserts having bright, black, and silver borders; cloth inserts in armrest area; vinyl stowage pockets; door closing assist straps; plus carpeting and bright trim strips on lower portions
- **Floor Covering:** Color-keyed carpeting
- **Headliner:** Perforated, color-keyed, molded cloth with fiber-glass blanket backing; includes matching retainer moldings

- **Instrument Cluster:** Voltmeter, oil pressure gage, and engine temperature gage replace warning lamps; includes pewter-toned brush-finished bezel
- **Instrument Panel Pad Applique:** Pewter-toned brushed finish with bright, black, and silver trim
- **Insulation:** Headliner insulator, extra-thick insulators for entire floor area
- **Seat:** Choice of: 1) all-vinyl leather grained trim; or 2) cut pile velour cloth/vinyl trim. See Interior and Exterior Color Selection Chart for color and trim availability
- **Steering Wheel:** Bright trim on horn button
- **Trim Panels:** Color-keyed molded plastic on windshield pillars and upper rear quarter panels
- **Visor Mirror:** On RH sun visor

C/K PICKUP

SILVERADO/SIERRA CLASSIC MODEL OPTION—RPO YE9 (FOR CREW CAB AND BONUS CAB MODELS)

This option includes all items in the Scottsdale/High Sierra model option plus the additions or substitutions listed below



Chevrolet model shown (GMC model available)

EXTERIOR

- **Bright Appearance Items:**

- "Silverado/Sierra Classic" nameplates, with serial designation, on front fenders

- Cab back panel applique molding

- "Chevrolet/GMC letters" nameplate on tailgate applique panel

- Chrome-trimmed grille and headlamp bezels (Chevrolet models only)

- Chevrolet emblem/GMC letters at grille center

- Body side and rear moldings with black paint trim (models with single rear wheels only)

- Wheel-opening lip moldings with black paint trim (models with

- single rear wheels only)

- Bright applique panel fitted over central area of tailgate with black-trimmed decorative border

- **Cab-to-Fender Insulators**

- **Grille and Headlamp Bezel Paint:** Dark argent (Chevrolet); argent/dark argent (GMC)

- **Hood Insulator**

- **Special Headlamps:** Rectangular; dual RH and LH

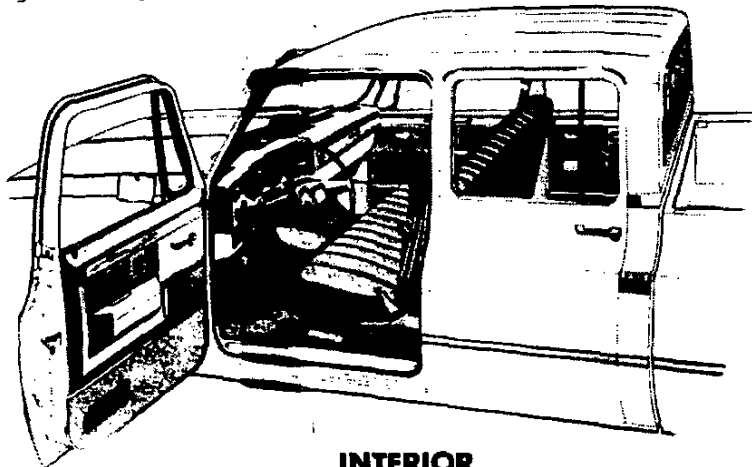

INTERIOR

- **Bright Appearance Items:**

- "Silverado/Sierra Classic" nameplate on instrument panel pad
- MM4 four-speed transmission shift lever (C2-3 models)
- Trim on door trim panels and horn button

- **Cowl Panel Trim:** Color-keyed molded plastic on exterior surface of cowl side panels

- **Door Trim Panels:** Special color-keyed molded plastic with pewter-toned brush-finished upper decorative insert having bright, black, and silver borders; cloth inserts in center area; vinyl storage pockets and door closing assist straps on front units only; plus carpeting and bright trim strips on lower portions

- **Floor Covering:** Color-keyed carpeting. (Except Bonus Cab rear compartment.)

- **Instrument Cluster:** Voltmeter, oil pressure gage, and engine temperature gage replace warning lamps; includes pewter-toned brush-finished bezel

- **Instrument Panel Pad Applique:** Pewter-toned brushed finish with bright, black, and silver trim

- **Insulation:** Extra-thick insulators for entire front and rear compartment floor areas, except under rear portion of Bonus Cab floor mat

- **Seats:** Choice of: 1) all-vinyl leather grained trim; or 2) cut pile velour cloth/vinyl trim. See Interior and Exterior Color Selection Chart for color and trim availability

- **Steering Wheel:** Bright trim on horn button

- **Visor Mirror:** On RH sun visor

C/K PICKUP

PICKUP SEAT

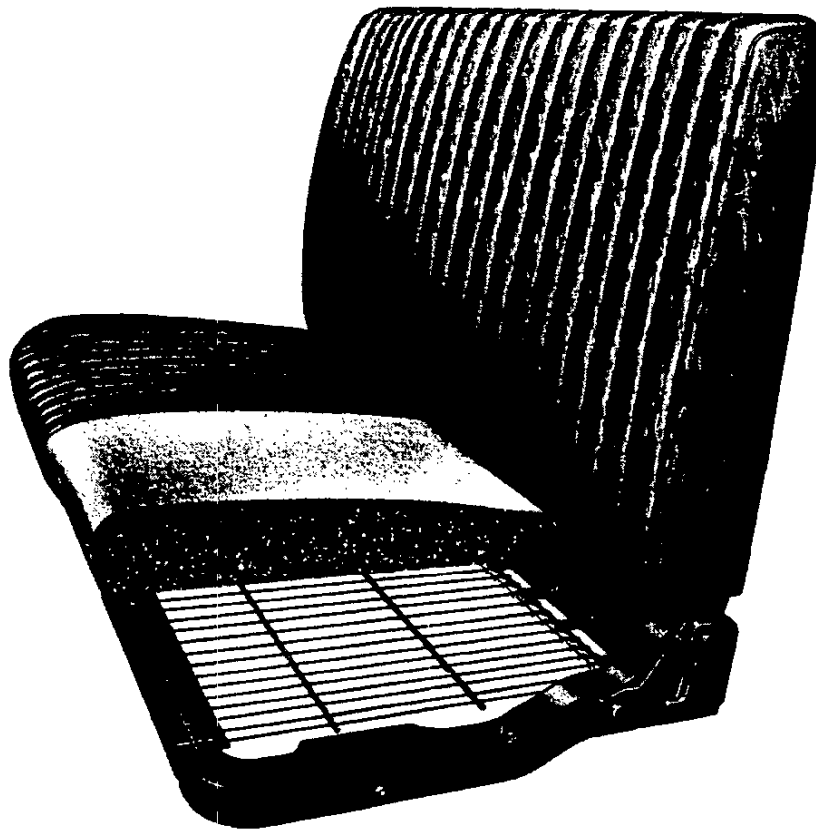

STANDARD FULL-DEPTH FOAM SEAT

Molded polyurethane foam pads over a steel cushion spring and frame assembly and a backrest frame assembly provide resilient support for driver and passengers, with an extra-thick pad employed for the cushion. A folding type backrest with inertia latch is used for the Regular Cab front seat and Crew Cab rear seat, providing convenient access to the stowage area behind the seat. Front seats are adjustable fore and aft. Trim is durable, easy-to-clean vinyl.

C/K PICKUP CAB CONSTRUCTION

Double-walled steel roof construction on regular cabs for structural rigidity. Synthetic rubber pads are used between the inner and outer panels for interior quietness.

Heavily reinforced welded steel pillars contribute to overall cab structural rigidity.

One-piece embossed rear outer panel and upper inner panel form double wall for torsional rigidity.

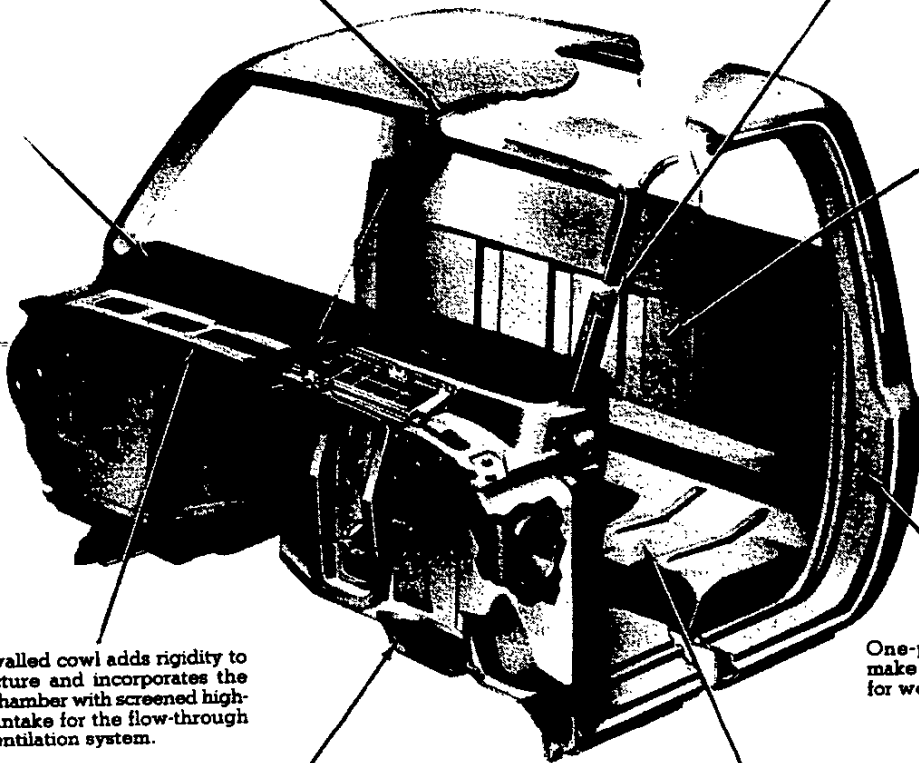

Double-walled cowl adds rigidity to cab structure and incorporates the plenum chamber with screened high-level air intake for the flow-through power ventilation system.

One-piece door opening frames make possible a precision fit of doors for weather tightness.

Toe panel has no openings. Drafts, dirt and water are kept out.

Embossed floor panel, with reinforcing ribs and sub-sills, stiffens cab structure.

CAB MOUNTINGS

Typical Cab Mount shown.

Both front and rear cab mounts used are the compression-rebound type for quietness and durability.

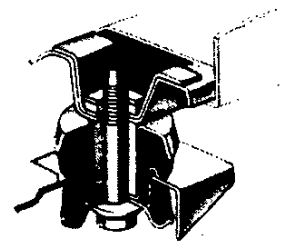

C/K PICKUP

STANDARD CAB FEATURES

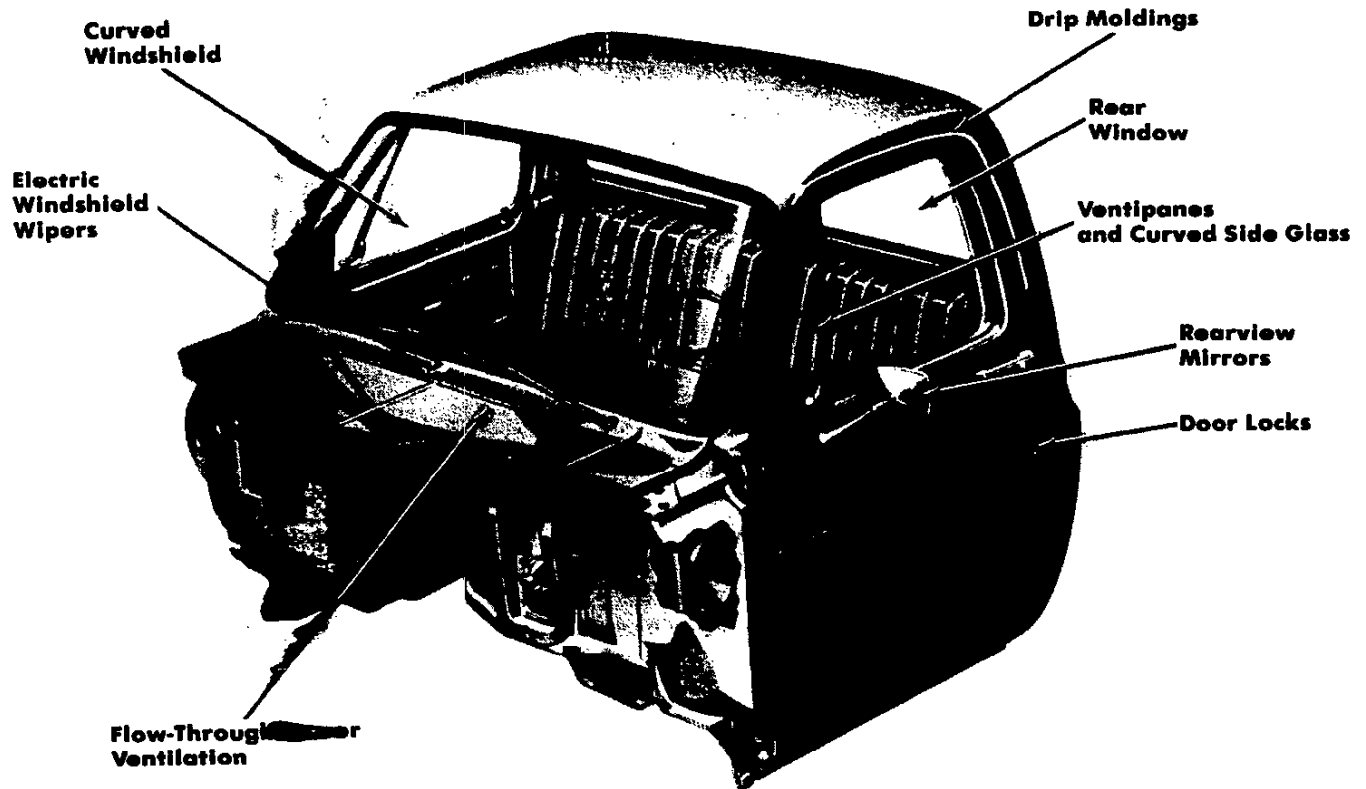

Curved Windshield—The one-piece windshield of laminated safety glass has an area of approximately 1447 square inches for excellent visibility.

Rear Window—The rear window is of solid safety glass with a 790 square inch area.

Electric Windshield Wipers—High capacity, 2-speed motor provides constant wiping action regardless of engine load or wiper position. Wipers have 16-inch blades. Wiper arms and the metal portions of the blades have a matte finish. Electric washers with a 3-pint capacity reservoir are also standard. Dual orifice washer nozzles assure efficient washing action.

Drip Moldings—Bright metal moldings over side doors.

Flow-Through Power Ventilation—With ignition switch on and heater fan switch on, outside air enters the cab through the louvers in the cowl air intake grille between the hood and the windshield—away from road

dust, heat and fumes. The air passes through screened inlets into a plenum chamber built into the cowl, where water is separated from the air and drained out. Air enters the driver compartment through the heater (or optional air conditioning) system and exits through a pressure relief valve in each door. Additional air may be admitted into the interior through two inlets—one on the right side (except with optional air conditioning) and one on the left side of the lower cowl structure. Inlet valves are operated by levers integral with the inlet assemblies.

Ventipanes and Curved Side Glass—Additional flow of outside air can be controlled by a pivot-type ventipane in each front door. Friction-type latches with push-button locks and smoothly contoured handles assure excellent sealing and security. Ventipanes, as well as curved door windows, are of solid safety glass with an area of 546 square inches for each side. (Crew Cab and Bonus Cab rear side door glass area—488

sq. in. each.)

Rearview Mirrors—Standard chrome exterior mirrors are of the fixed arm type with 5-7/16" wide x 4" high adjustable heads. Both right-hand and left-hand units are provided.

Many optional mirror combinations are also available. See the Optional Equipment listing for each model.

Door Locks—All cab models include left & right hand key-operated (front) door locks as standard equipment. Depression of inside pushbuttons prevents accidental front and rear door opening and provides keyless front door locking when leaving the vehicle. Door lock key is separate from the ignition key for theft protection.

Identification and Clearance Lights—All models with second unit bodies 80" wide or over, or models with dual rear wheels, are equipped with cab identification and clearance lights. See individual model specification pages.

C/K PICKUP CAB DIMENSIONS*

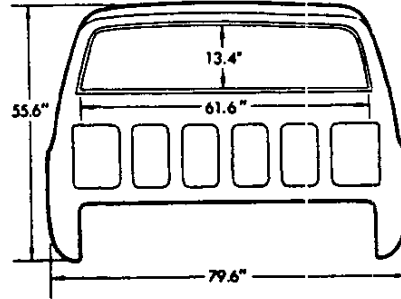
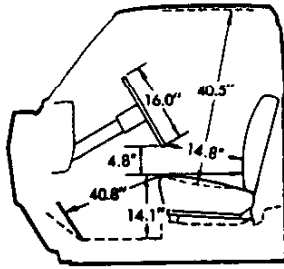
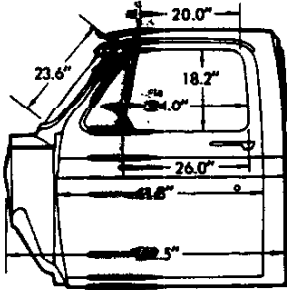

Glass Area (sq. in.)

<p>Windshield..... 1447</p> <p>Front side door window (each side) including ventpanes..... 546</p>	<p>Rear side door window (each side) on Crew Cab including fixed window. 488</p> <p>Rear window..... 790</p>
--	--

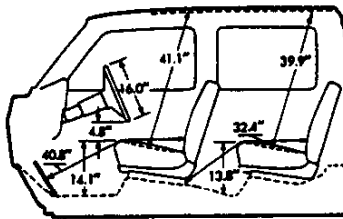
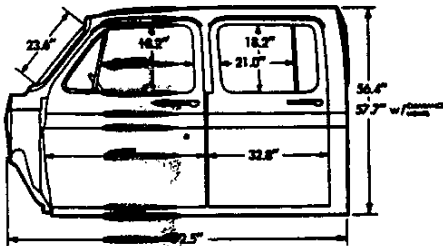

(Crew Cab model)

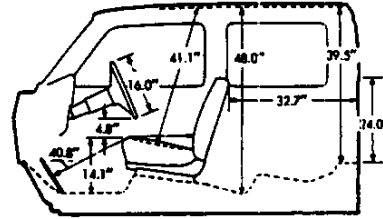

(Bonus Cab model)

*All interior dimensions measured with front seat in rearmost position. Seat travel is 5"

INSTRUMENT CLUSTERS

Standard Cluster with warning lights for engine temperature, generator, and oil pressure. Diesel engine models will also have warning lights for glow plugs, low coolant and water level (or fuel filter).

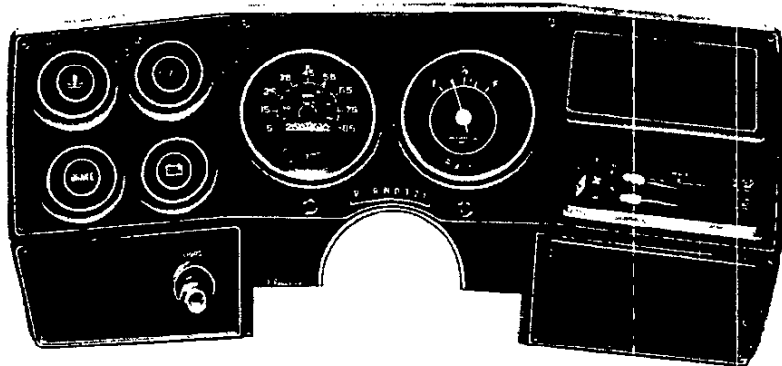

Optional Cluster (RPO Z53) with volt-meter, engine temperature gage, and oil pressure gage. Included in Silverado/Sierra Classic model (RPO YE9) along with bright brass finished trim, as illustrated. Cluster available for Custom Deluxe/Sierra (Std.) models has black crackle finish. An electric clock (RPO U35), shown at lower left, is available for use with the optional cluster.

Optional air conditioning outlets and radio also shown in illustration.

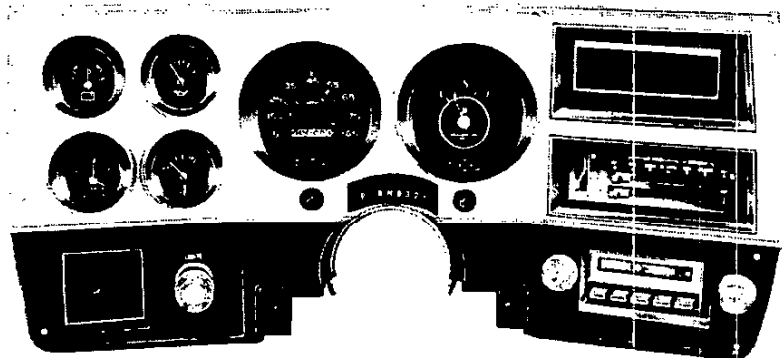

C/K PICKUP FLEETSIDE/WIDESIDE PICKUP BOX

DUAL REAR WHEEL APPLICATION

Body Ordering Code E63

DIMENSIONS

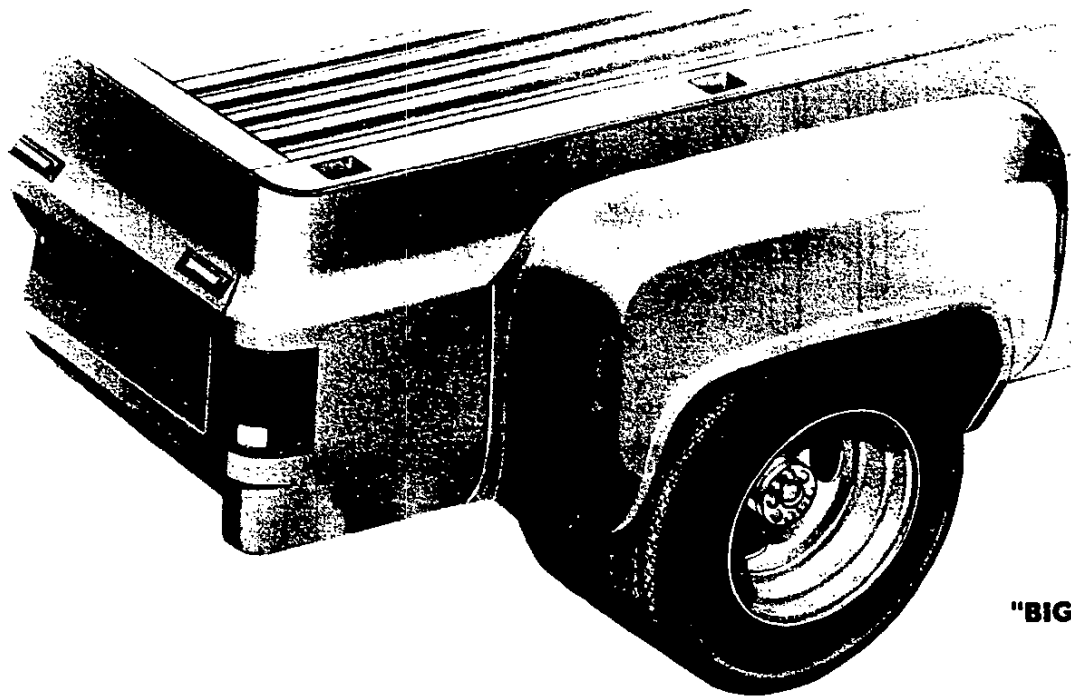

"BIG DOOLEY"

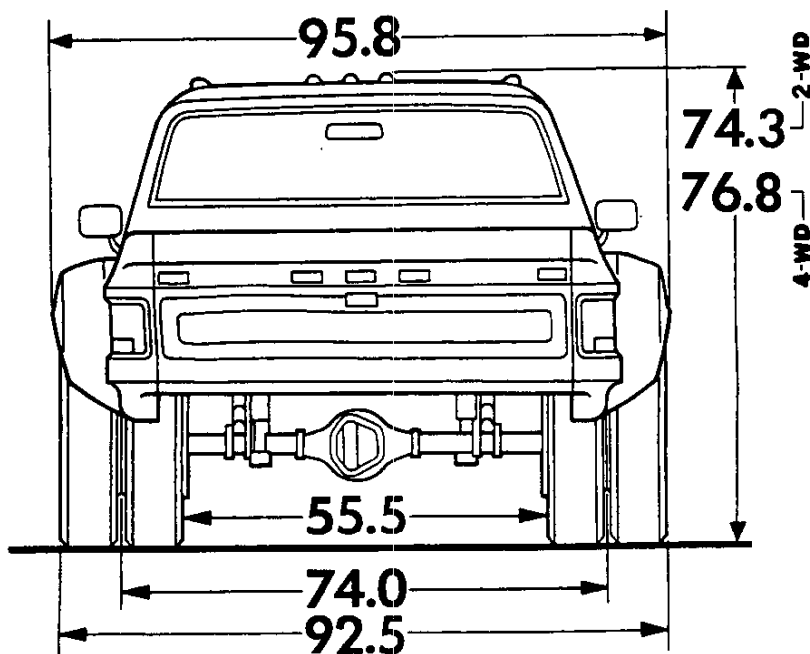

The 8-foot Fleetside/Wideside Pickup Box for dual rear wheel application offers all the features described for single rear wheel application. Additionally, it includes one-piece fenders constructed of fiberglass reinforced plastic bolted to each rear wheelhousing area. This provides an extension to cover the dual rear wheel equipment. Clearance lights are located fore and aft of the wheel openings on the fender extensions. Installation also includes five amber clearance and identification lights mounted on the cab roof along with five red rear clearance and identification lamps mounted on the tailgate (except on Series K30/3500 models where they are standard).

Fleetside/Wideside Pickup Box (Code E63) and dual rear wheels (RPO R05) are available only on models C30903, K30903, C30943, or K30943.

Dana wider track rear axle used when dual rear wheels are ordered on Fleetside/Wideside pickups.

C/K PICKUP FLEETSIDE/WIDESIDE PICKUP BOX

SINGLE WHEEL APPLICATION

Body Ordering Code E63

DIMENSIONS

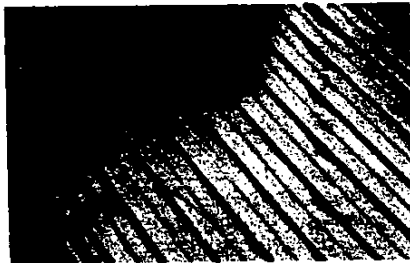
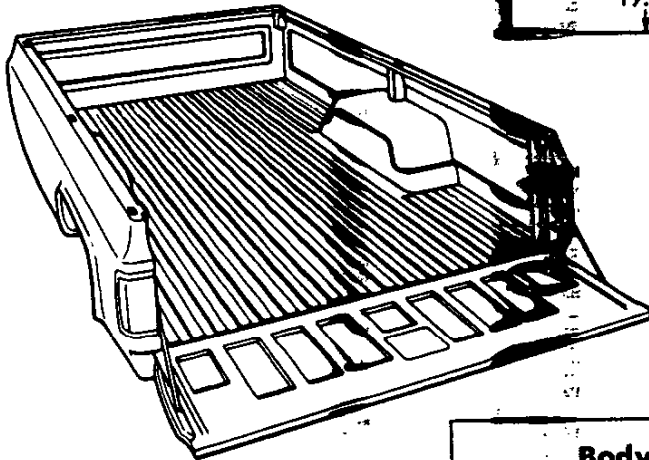
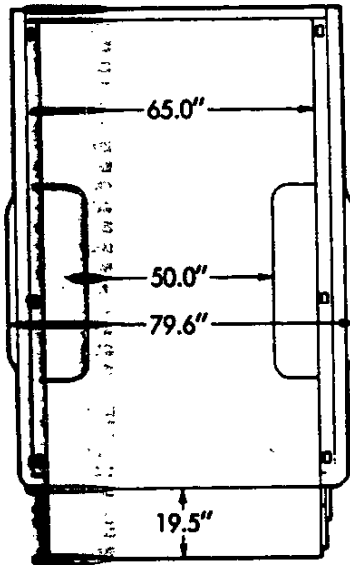
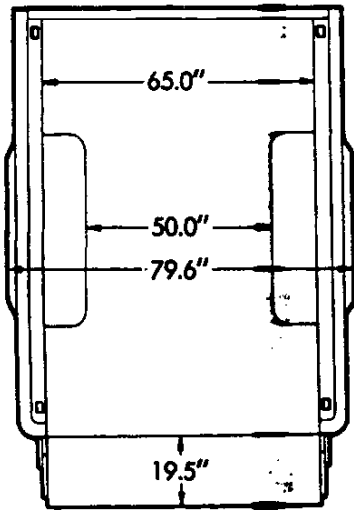

Steel Floor

Body Sizes

Model	Body Length Inside	Volume
C3000	78.2"	58.4 cu ft
C3000B		
C3000C	98.1"	74.3 cu ft
C3000D		
C3000E		
C3000F		
C3000G		
C3000H		

Stake Pocket Locations

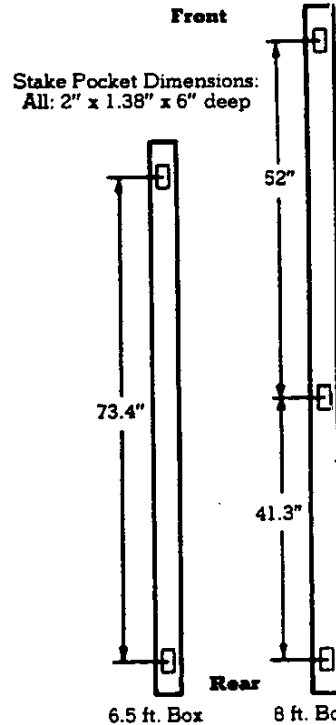

Fleetside/Wideside pickup boxes feature double-walled construction in the side panels and tailgate to prevent load dents from marring the appearance of the outer panels.

All metal body panels are primed for corrosion protection, and the Elpc electro-coating process is used to prime the side panels, tailgate, floor panel, and front panel to assure that all surfaces of these more complicated components—even surfaces not visible—receive a coat of prime paint. Side outer panels and tailgate are fabricated of zinc coated steel and galvanized steel is used for stake pockets, platform panels, and rear wheelhoussings to provide additional corrosion protection.

A tight-fitting full-width tailgate holds such loads as grain and sand with minimal loss. It is operated by a mechanically actuated latch and retained in the horizontal position by hinged steel support straps. A quick-release feature allows it to be quickly and easily removed and re-installed by one person. The tailgate latch features one-hand operation for easy opening and closing.

Reinforced pockets (2" x 1.38") for the addition of stake racks are provided to increase the bulk carrying capacity of the box. On 6.5 ft. bodies there are two pockets on each side; on 8 ft. bodies there are three pockets on each side. See the diagram at right above for location of these stake pockets.

C/K PICKUP STEPSIDE/FENDERSIDE PICKUP BOX

Body Ordering Code E62

DIMENSIONS

Stake Pocket Locations

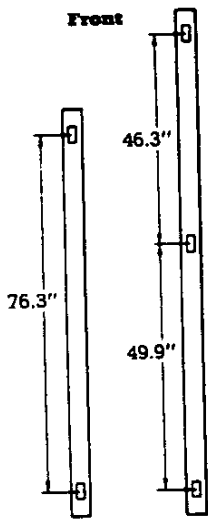

6.5 ft. Box 8 ft. Box
Rear

Stake Pocket Dimensions
Front & rear: 2" x 1.38" x 6" deep
Center (8 ft. box only) 2" x 1.38" x 1.8" deep

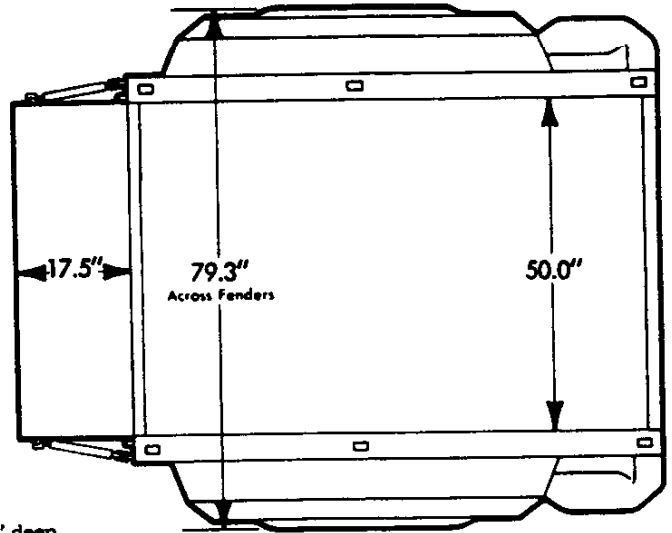

Body Sizes		
Model	Body Length Inside	Volume
C10703	78.4"	39.7 cu ft
K10703		
C20903	98.3"	49.8 cu ft
C30903		
K20903		

The smooth interior walls of the Stepside/Fenderside pickups are a full 50 inches apart, allowing 4-ft-width materials to be carried easily. In fact, with the 98" body, 4' x 8' sheets can be carried without lowering the tailgate.

Floors are constructed of kiln-dried, sealed wood boards with seven flush steel skid strips bolted in place over the expansion joints. A tight-fitting full-width tailgate minimizes loss of bulk loads such as grain or sand. With the tailgate closed, the wedge-type anti-rattle latches give extra support to the side panels. When open, the tailgate is supported by two strong vinyl covered chains.

On each side of the body, Stepside/Fenderside pickups have a running board and step just forward of the fender. This step is a great convenience in jobs requiring frequent

working of the load from the side.

Reinforced pockets (2" x 1.38") for the addition of stake racks are provided to increase the bulk carrying capacity of the box. On 6.5 ft. bodies there are 2 pockets on each side and on 8 ft. bodies there are 3 pockets on each side. See the diagram at left above for location of these stake pockets.

Side panels, tailgate, and front panel are fabricated of 2-side galvanized steel as are the platform cross sills and skid strips.

All metal body panels are primed for corrosion protection, and the Elpo electro-coating process is used to prime the side panels, tailgate, and front panel to assure that all surfaces of these more complicated components—even surfaces not visible—receive a coat of prime paint.



Convenient Side Step

A convenient running board and step on each side of the body facilitates working of cargo from the side.

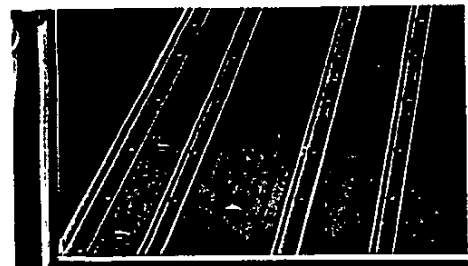
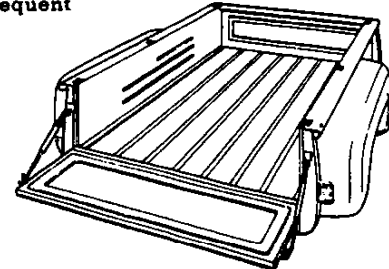

Steel Skid Strips

Seven flush steel skid strips hold floor planks securely, yet allow expansion with changes in temperature and humidity. Recessed bolt heads prevent cargo damage in loading and unloading.

C/K PICKUP

INTERIOR AND EXTERIOR COLOR AVAILABILITY CHART

Please Note: Below are the interior trim color and exterior paint combinations recommended by Chevrolet/GMC. The only available primary/secondary exterior color combinations are those shown in the chart below; however, any available interior trim color may be ordered with one of these exterior color combinations if that particular combination is desired by the customer.

Paint Applications

INTERIOR COLORS		REGULAR CAB						BONUS/CREW CAB			
		Decor	Blue	Burgundy	Charcoal	Mahogany	Saddle Tan	Blue	Burgundy	Saddle Tan	
CUSTOM DELUXE/SIERRA		Std.	VDD1	VEE1	VJJ1	VNN1	VSS1	VDD1	VEE1	VSS1	
Vinyl Bench Seat			CDD1	CEE1	CJJ1	CNN1	CSS1				
Deluxe Cloth Bench Seat			XDD1	XEE1	XJJ1	XNN1	XSS1				
Custom Vinyl Bench Seat											
SCOTTSDALE/HIGH SIERRA		Z62						VDD1	VEE1	VSS1	
Vinyl Bench Seat			CDD1	CEE1	CJJ1	CNN1	CSS1				
Deluxe Cloth Bench Seat			XDD1	XEE1	XJJ1	XNN1	XSS1	XDD1	XEE1	XSS1	
Custom Vinyl Bench Seat								LDD1	LEE1	LSS1	
Custom Cloth Bench Seat											
SILVERADO/SIERRA CLASSIC		YE9	XDD1	XEE1	XJJ1	XNN1	XSS1	XDD1	XEE1	XSS1	
Custom Vinyl Bench Seat			LDD1	LEE1	LJJ1	LNN1	LSS1	LDD1	LEE1	LSS1	
Custom Cloth Bench Seat											
EXTERIOR COLORS w/ZY1, ZY2, ZY3, ZY4 PAINT		Primary	Secondary	RECOMMENDED INTERIOR TRIM COLOR							
BLACK, MIDNIGHT		19	19		X	X	X	X		X	X
Silver (Metallic)		19	17			X					
Tan, Doeskin		19	61			X		X			X
White, Frost		19	12			X					
BLUE, LIGHT (Metallic)		21	21	X		X			X		
Blue, Midnight		21	29	X					X		
Silver (Metallic)		21	17	X					X		
White, Frost		21	12	X					X		
BLUE, MIDNIGHT		29	29	X		X			X		
Silver (Metallic)		29	17	X					X		
White, Frost		29	12	X					X		
BRONZE, INDIAN (Metallic)		66	66				X	X			X
Tan, Doeskin		66	61				X	X			X
White, Frost		66	12				X	X			X
RED, APPLE		72	72		X	X		X		X	X
Silver (Metallic)		72	17		X	X				X	X
Tan, Doeskin		72	61		X	X		X		X	X
White, Frost		72	12		X				X		
SAND, DESERT (Metallic)		64	64			X	X	X			X
Black, Midnight		64	19			X		X			X
Tan, Doeskin		64	61					X			X
White, Frost		64	12					X			X
SILVER (Metallic)		17	17	X	X	X			X	X	
Black, Midnight		17	19			X					
Blue, Midnight		17	29	X					X		
Red, Apple		17	72			X					
White, Frost		17	12			X					
TAN, DOESKIN		61	61			X	X	X			X
Black, Midnight		61	19			X		X			X
White, Frost		61	12				X	X			X
WHITE, FROST		12	12	X	X	X	X	X	X	X	X
Black, Midnight		12	19		X	X				X	
Blue, Midnight		12	29	X					X		
Red, Apple		12	72		X					X	
Tan, Doeskin		12	61					X			X
YELLOW, COLONIAL		53	53			X	X	X			X
Black, Midnight		53	19			X		X			X
Tan, Doeskin		53	61					X			X
White, Frost		53	12					X			X
w/ZY5 or ZY9 PAINT (Interior & Exterior Combinations Shown are the Only Combinations Available)											
BLACK, MIDNIGHT/Silver (Metallic)		19	17		X	X			X		Vermillion/Black
BLACK, MIDNIGHT/Tan, Doeskin		19	61		X	X		X	X	X	Vermillion/Black
BLUE, LIGHT (Metallic)/Blue, Midnight		21	29	X				X			Light Blue/Dark Blue
BLUE, LIGHT (Metallic)/Silver (Metallic)		21	17	X				X			Dark Blue/Light Slate
BLUE, LIGHT (Metallic)/White, Frost		21	12	X				X			Dark Blue/Light Slate
BLUE, MIDNIGHT/Silver (Metallic)		29	17	X				X			Vermillion/Light Slate
BRONZE, INDIAN (Metallic)/Tan, Doeskin		66	61				X	X			Almond/Dark Brown
RED, APPLE/Black, Midnight		72	19		X	X			X		Vermillion/Black
RED, APPLE/Tan, Doeskin		72	61		X	X		X	X	X	Vermillion/Dark Carmine
RED, APPLE/White, Frost		72	12		X				X		Vermillion/Black
SILVER (Metallic)/Black, Midnight		17	19		X	X			X		Vermillion/Black
SILVER (Metallic)/Blue, Midnight		17	29	X		X		X			Light Blue/Dark Blue
SILVER (Metallic)/Red, Apple		17	72		X	X			X		Vermillion/Black
TAN, DOESKIN/Black, Midnight		61	19			X		X			Vermillion/Black
TAN, DOESKIN/Red, Apple		61	72					X			Vermillion/Dark Carmine
YELLOW, COLONIAL/Tan, Doeskin		53	61					X			Almond/Dark Brown
YELLOW, COLONIAL/White, Frost		53	12			X	X			X	Almond/Dark Brown

C/K PICKUP

SOLID AND TWO-TONE* EXTERIOR COLOR COMBINATIONS

The application of paint for solid and two-tone exterior color combinations is shown below.

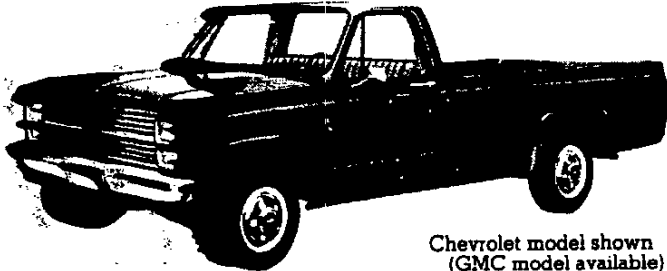

Chevrolet model shown
(GMC model available)

Solid color paint (ZY1) is standard on all models. All painted areas of the cab, front end sheet metal, and box are the same color. A white decal is applied to the raised "Chevrolet/GMC" lettering on the tailgate, except with Frost White, then a black decal is applied. (A bright trim plate covers the lettering on Fleetside/Wideside models when the Silverado/Sierra Classic Model Option is ordered.)

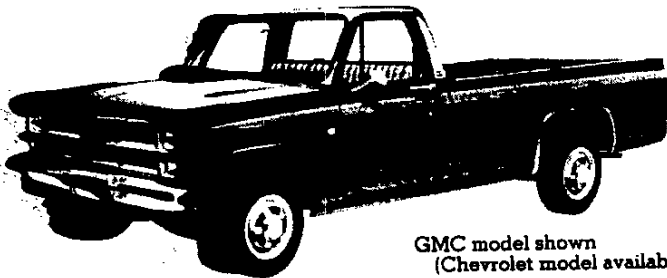

GMC model shown
(Chevrolet model available)

Conventional two-tone (ZY2) consists of the secondary color on cab roof and cab back panel above the belt line, with the elected primary color on the remainder of the cab, on the front end sheet metal, and on the pickup box. A white decal is applied to the raised "Chevrolet/GMC" lettering on the tailgate, except when the primary color is Frost White, then a black decal is applied. (A bright trim plate covers the lettering on Fleetside/Wideside models when the Silverado/Sierra Classic Model Option is ordered.) Includes cab back panel applique and molding, except with the Silverado/Sierra Classic Model Option where it is already included.

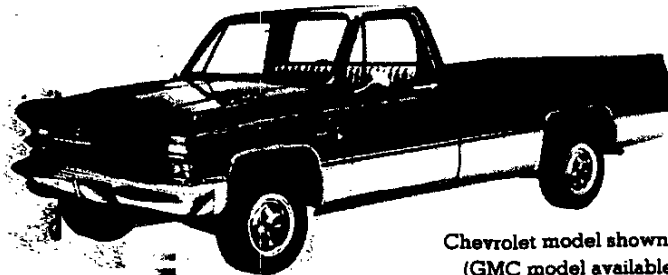

Chevrolet model shown
(GMC model available)

Special two-tone (ZY3) paint colors are available only on single rear wheel Fleetside/Wideside Pickup models and include the YG1 molding package consisting of black vinyl body side and rear moldings with bright trim, bright wheel opening moldings, and bright trim for front side marker lights and tail lights (except with the YG3 molding package or the Silverado/Sierra Classic Model Option where bright body side and rear moldings with black paint trim are substituted). The primary color is applied to the areas above the moldings (including the cab roof). The secondary color is applied to the areas below the moldings. A white decal is applied to the raised "Chevrolet/GMC" lettering on the tailgate, except when the primary color is Frost White, then a black decal is applied. (A bright trim plate covers the lettering when the Silverado/Sierra Classic Model Option is ordered.)

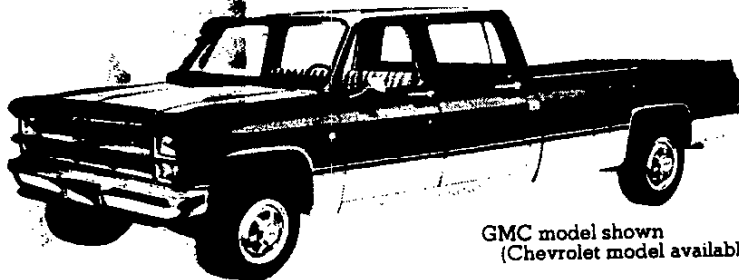

GMC model shown
(Chevrolet model available)

*Optional at extra cost

C/K PICKUP

SOLID AND TWO-TONE* EXTERIOR COLOR COMBINATIONS

The application of paint for solid and two-tone exterior color combinations is shown below.

Deluxe two-tone (ZY4) paint colors are available only on single wheel Fleetside/Wideside Pickup models and include the YG1 molding package consisting of black body side and rear moldings with bright trim, bright wheel opening moldings, and bright trim for front side marker lights and tail lights (except with the YG3 molding package or the Silverado/Sierra Classic Model Option where bright body side and rear moldings with black trim are substituted). Also includes cab back panel applique and molding (except with Silverado/Sierra Classic Model Option where this is included). The cab roof, cab back panel above the belt line, and the area below the moldings are painted the secondary color with the primary color applied on all other areas. A white decal is applied to the raised "Chevrolet/GMC" lettering on the tailgate, except when the primary color is Frost White, then a black decal is applied. A bright trim strip covers the lettering when the Silverado/Sierra Classic Model Option is ordered.

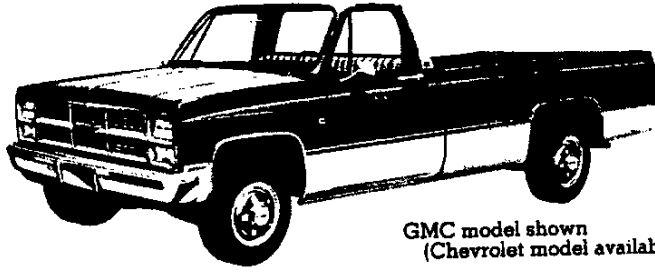

GMC model shown
(Chevrolet model available)



Chevrolet model shown
(GMC model available)

Exterior Decor Package (Z34) paint colors and trim are available only on single wheel Fleetside/Wideside pickup models (see letter and Exterior Color Availability Chart). The package includes the moldings described under Special Two-Tone. In addition, it includes dual-tone body side and rear decal striping keyed to the exterior body color. This striping is applied to the front fenders, side doors and pickup box sides and tailgate a few inches above the styling crease line.

The areas above the striping and below the moldings are painted the primary paint color. The secondary color choice is used between the striping and the molding. A dual spring-loaded, stand-up type dual ornament is included on gasoline engine models.

When used with the Silverado/Sierra Classic Model Option, the cab back panel applique and molding included with this model is deleted.

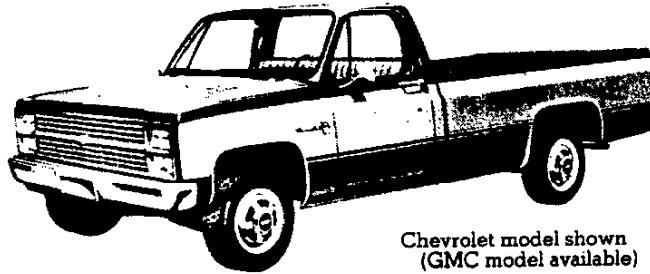

Chevrolet model shown
(GMC model available)



GMC model shown
(Chevrolet model available)

*Optional at extra cost

C/K PICKUP

SOLID AND TWO-TONE* EXTERIOR COLOR COMBINATIONS

The application of paint for solid and two-tone exterior color combinations is shown below.

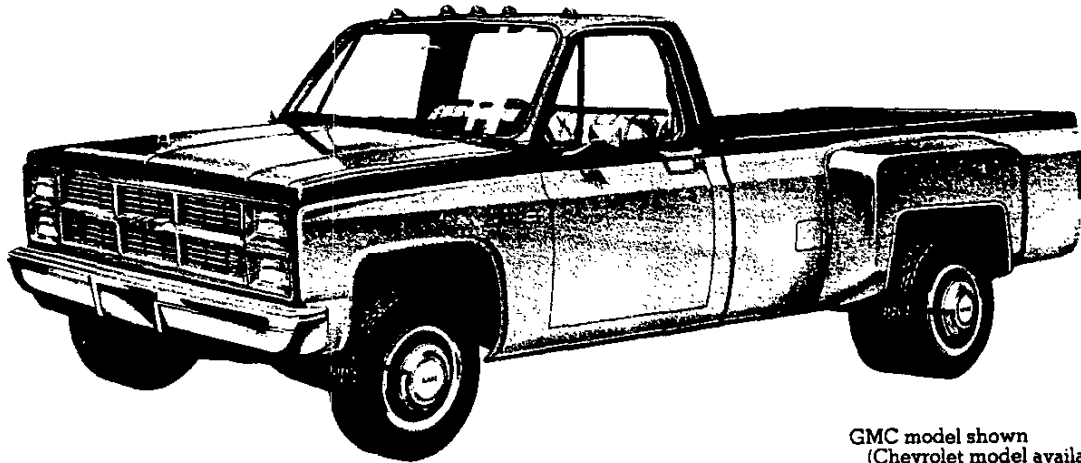

GMC model shown
(Chevrolet model available)

Special Big Dooley two-tone (ZY9) paint colors are available only on Fleetside/Wideside Pickup models with dual rear wheels (see Interior and Exterior Color Availability Chart). The package includes dual-tone body side and rear tape decal striping keyed to the exterior body color. This striping is applied to the front fenders, side doors and pickup box sides and tailgate a few inches above the styling crease line. The areas above the striping are painted the primary paint color, and

the areas below are painted the secondary color. A bright, spring-loaded, stand-up type hood ornament is included on gasoline engine models. Bright trim for front side marker lamps, rear wheel opening extension clearance lamps, and tail lamps also is included for standard Custom Deluxe/Sierra models.

When used with the Silverado/Sierra Classic Model Option, the cab back panel applique and molding included with this model is deleted.

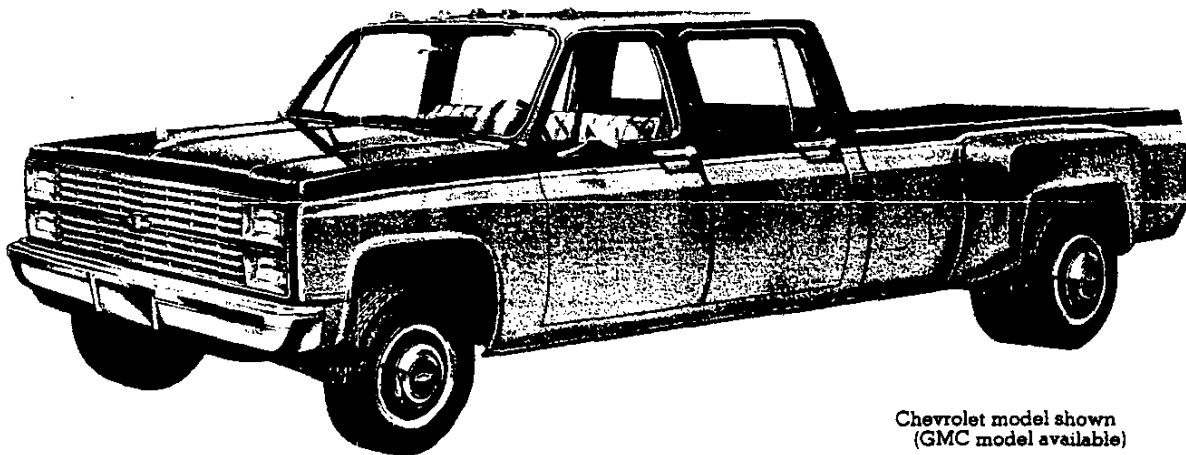

Chevrolet model shown
(GMC model available)

*Optional at extra cost

C/K PICKUP

YJ6 VALUE DECOR PACKAGE

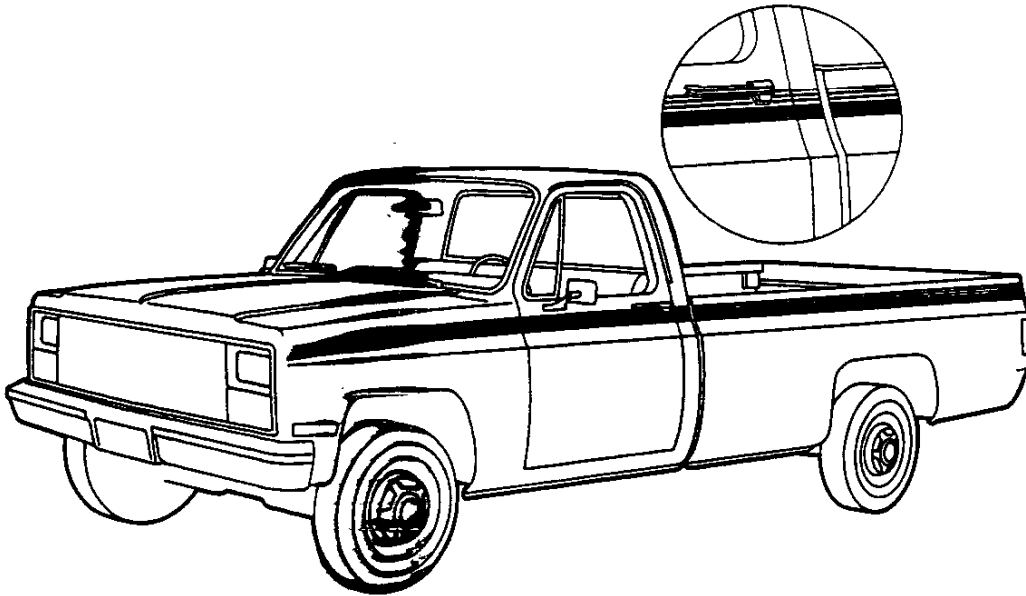

YJ6 BLUE DECOR PACKAGE

(C/K Fleetside/White Pickups with single rear wheels only)

The Value Decor stripe package is available in four colors, and requires ZY1 solid paint. See the chart below for color availability. The stripes are applied a few inches above the styling crease line on the front fenders, side doors and pickup box sides and tailgate. The bottom stripe is 1½" wide and the three upper ¼" stripes are separated by a ¼" clear space which allows the exterior paint color to show through between them. Includes a blacked-out grille and headlamp bezel treatment on all models and Rally wheels on C/K 10/1500 models. Not available with YJ9 Scramble/Sierra Classic Trim, R05 Dual Rear Wheels or body side moldings.

YJ6 COLOR AVAILABILITY CHART

Exterior Color	Primary	Secondary	Available Stripe Colors			
			White	Red	Blue	Black
Black, Midnight	19	19	X	X		
Blue, Light (Metallic)	21	21	X		X	X
Blue, Midnight	29	29	X		X	
Bronze, Indian (Metallic)	66	66	X			
Red, Apple	72	72	X			X
Sand, Desert (Metallic)	64	64	X	X		X
Silver (Metallic)	17	17	X	X	X	X
Tan, Doeskin	61	61	X	X		X
White, Frost	12	12		X	X	X
Yellow, Colonial	53	53	X			X

1984 GENERAL MOTORS CORPORATION

INFORMATION REGARDING

CONSUMER INFORMATION TRUCK-CAMPER LOADING

PUBLISHED MAY, 1983

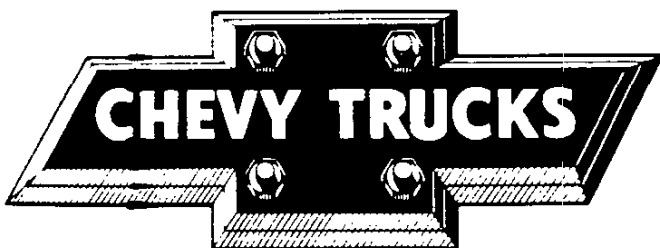

CHEVROLET MOTOR DIVISION
GENERAL MOTORS CORPORATION
WARREN, MICHIGAN 48090



GMC TRUCK & COACH OPERATIONS
GENERAL MOTORS CORPORATION
PONTIAC, MICHIGAN 48058

1984 GENERAL MOTORS TRUCKS

Consumer Information **Truck - Camper Loading**

CONSUMER INFORMATION REGULATION 575.103 issued by the National Highway Traffic Safety Administration requires manufacturers of trucks capable of accommodating slide-in camper bodies to provide information concerning proper load and proper load distribution in truck-camper applications.

This Consumer Information booklet is designed to provide basic information relating to load capabilities of 1984 General Motors Truck models which are adaptable to slide-in camper applications. Information contained herein is applicable to the truck buyer that already owns a 1984 General Motors Truck or the prospective truck purchaser.

See the General Motors Corporation Light Duty Truck Data Book for additional information required to completely spec out your vehicle for the proper slide-in camper accommodation.

The Regulation also provides that proper truck-camper loading information is to be maintained in truck dealerships and be made available to all prospects on request. This booklet relates to the 1984 General Motors Truck models recommended for slide-in camper applications and is to be used as a consumer information piece.

Product specifications or data contained herein may change periodically. When a revision of this booklet is supplied to truck dealers, it is the dealers' responsibility to make the revised information available to the public.

All illustrations and specifications contained in this literature are based on the latest product information available at the time of publication approval. The right is reserved to make changes at any time in prices, colors, materials, equipment, specifications and models, and also to discontinue models.

TRUCK-CAMPER LOADING

Consumer Information Regulation 575.103 requires manufacturers of trucks that would accommodate side-in campers to specify the vehicle's Cargo Weight Rating (CWR) and the longitudinal limits within which the center of gravity for the cargo weight rating should be located.

Cargo Weight Rating (CWR)—The cargo weight rating of a vehicle means the value specified by the manufacturer as the cargo-carrying capacity of a vehicle, in pounds, exclusive of (minus) the weight of occupants, computed as 150 pounds times the number of designated seating positions.

Longitudinal Center of Gravity Zone for CWR (CG)—The forward limit of the recommended CG Zone is determined by the application of dimension "A" measured in inches from the rear of the truck bed. The rearward limit of the recommended CG Zone is established by application of dimension "B", also measured in inches from the rear of the truck bed. The recommended CG Zone lies between these points.

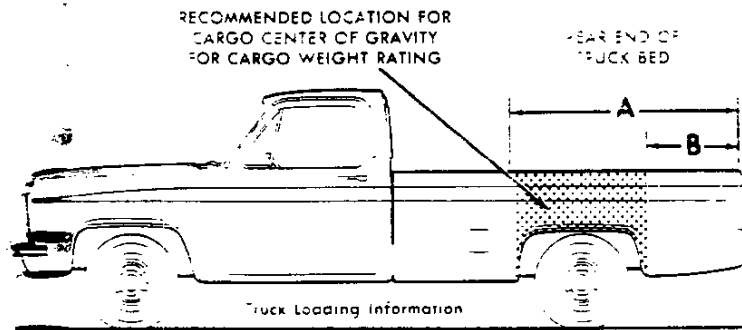

_____ # _____
Calculated
Cargo Weight Rating

_____ Dimension B _____

Restrictions on Recommended CG Zones

FORWARD LIMIT

- 1) Must not extend beyond the inside surface (dimension IL shown on line drawings) of the pickup box.
- 2) Must not exceed the front gross axle weight rating (GAWR).

REARWARD LIMIT

- 1) Must be no farther rearward than the inside surface (dimension IL shown on line drawings) of the pickup box.
- 2) Must not exceed the gross axle weight rating on the rear axle.
- 3) On S/T-10/15 and Series C, K-10/1500 trucks the rear axle loading is limited to 62% of the vehicle's Gross Vehicle Weight Rating (GVWR).
- 4) On Series C, K-20/3500 and C, K-30/3500 trucks the rear axle loading is limited to 70% of the vehicle's Gross Vehicle Weight Rating (GVWR).

Vehicle (CG) Identification—All General Motors Corporation trucks that may be suitable for carrying a side-in camper incorporate a Truck-Camper Loading information label located on the inside of the glove box door on C, K models, or on the trailing edge of the driver's door on S, T-10/15 models. The vehicle identification number (VIN), the as-manufactured cargo weight rating (CWR) of that vehicle plus the CG limits of dimension "A" and "B" for that vehicle in inches are included.

Vehicle and Truck-Camper Loading are also discussed at length in the first few pages of the Vehicle Owners Manual.

TRUCK - CAMPER LOADING

Loading Instructions - When the truck is used to carry a slide-in camper, the total cargo load of the truck consists of the manufacturer's camper weight figure, the weight of installed auxiliary camper equipment not included in the manufacturer's camper weight figure, the weight of camper cargo and the weight of passengers in the camper. The total cargo load should not exceed the truck's cargo weight rating (CWR) and the camper's center of gravity should fall within the truck's recommended center of gravity zone when installed.

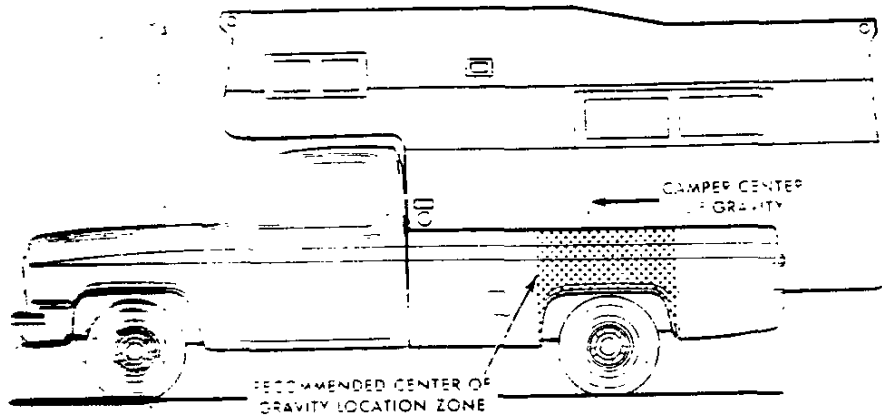

Any accessories or equipment added to this vehicle, after initial date of manufacture, must be weighed or have their weight determined, and the weight determined must not exceed the cargo weight rating (CWR) of this vehicle. This may decrease the permissible longitudinal zone of the center of gravity for this vehicle.

The longitudinal center of gravity zone has been determined for the full cargo capacity of this truck. If a slide-in camper has a total weight less than the cargo weight rating (CWR), the permissible longitudinal zone of the center of gravity may be larger; however, maximum axle loads should not exceed either of the gross axle weight ratings (GAWR).

Excessive front or rear wheel weight may affect the balance of your vehicle. When the vehicle is parked on a level surface, weigh on the front and on the rear wheels separately to determine the axle loads. Individual axle loads should not exceed either of the gross axle weight ratings (GAWR). The total of the axle loads should not exceed the gross vehicle weight rating (GVWR). These ratings are given on the vehicle identification plate and on the vehicle certification label. Both are located on the side of the vehicle, normally on the floor plate next to the door edge next to the driver. If weight ratings are exceeded, move or remove items from the vehicle until the ratings are met.

CAUTION: The longitudinal center of gravity is only one of the many factors which may affect the overall performance of a vehicle, including handling, steering and braking. The recommended longitudinal limits for the camper's center of gravity are based on the assumption that the vehicle will be operated with reasonable tire pressures and under the existing conditions. Failure to do so could result in unsatisfactory vehicle performance and could make the vehicle unsafe to operate.

Obtain information about any recommendations by the slide-in camper manufacturer regarding installation and loading of the camper.

TRUCK-CAMPER LOADING

DEFINITION OF TERMS

For the purpose of calculating Truck-Camper Loading, the terms listed below are some common terms and abbreviations:

Cargo Weight Rating (CWR)—means the value specified by the vehicle manufacturer as the cargo-carrying capacity, in pounds, of a vehicle, exclusive of (minus) the weight of occupants, computed as 150 pounds times the number of designated seating positions.

Center of Gravity (CG)—Point where the mass of a body is concentrated and if suspended at ~~the~~ point would balance front and rear.

Curb Weight—Weight of a vehicle without driver, passengers or cargo but including fuel, ~~tools~~ and other items of standard equipment.

Dimension A & B—Center of Gravity (CG) zone

Gross Vehicle Weight Rating or "GVWR" means the value specified by the manufacturer as the loaded weight of a single vehicle.

Gross Axle Weight Rating or "GAWR" means the value specified by the vehicle manufacturer as the load-carrying capacity of a single axle system, measured at the tire-ground interface.

Model Weight—Weight of the vehicle with all items of standard equipment, 150 pounds per passenger in each designated seating position and maximum capacity of fuel, oil and ~~fluids~~.

Payload Rating—The maximum allowable load, including the weight of the driver and all occupants, that the vehicle can carry based on all factory-installed equipment on the vehicle.

Slide-in Camper—means a camper having a roof, floor, and sides, designed to be mounted on ~~an~~ ~~removable~~ from the cargo area of a truck or the bed.

Weight Distribution—The amount of a vehicle's weight that rests on each axle.

Wheelbase (WB)—The distance from the center axle of the front axle to the center line of the rear axle.

LIMITATIONS

The following General Motors truck models are not recommended for slide-in camper applications:

- El Camino Cabalers—All models
- Any pickup model with a cargo weight rating of less than 500 lbs.

A statement is mounted on the Truck-Camper Loading information label, which states that the vehicle should not be used to carry a slide-in camper.

- S T40 15 Pickup with 100-lb. payload
- S T40 15 Pickup with 108 3/4" WB
- S T40 15 Extended Cab Pickup

Note: S10 1500 Pickups should not be used for larger, cap-over-type slide-in campers.

~~TRUCK~~ CAMPER LOADING

C/K PICKUPS

INSTRUCTIONS

VEHICLE SELECTION AND WEIGHT ANALYSIS

From the model selector in the C/K ~~Section~~ of the General Motors Light Duty Truck Data Book, select the pickup truck model you desire. ~~Select~~ the GVWR selector for the selected model. Select the GVWR you require and note the minimum ~~size~~ and chassis equipment required for that GVWR. To approximate the GVWR you require, add your ~~camp~~ camper weight to the vehicle model weight shown on the appropriate model weight and dimension ~~page~~ of the Data Book. Record this information on the C/K Pickup Computation sheet, page 7.

- Record the front and rear model weights of your selected vehicle.
- In the appropriate sections of the ~~computation~~ sheet, record the chassis equipment you desire: tires, shock absorbers, etc. Keep in mind you must select suspension equipment having load capacities equal to or greater than those of the ~~minimum~~ equipment required for your selected GVW rating. (The capacities of standard springs are shown on the standard specification pages.) Record the front and rear weight of each piece of equipment and the ~~capacity~~ capacity of the springs and tires in the appropriate columns.
- Add all other factory-installed options you desire with their front and rear weights on the C/K Pickup Computation sheet.
- Total the front and rear weights of ~~vehicle~~ model and options to arrive at the total front and rear weight of the vehicle.*
- Subtract the total front and rear ~~weights~~ of the vehicle from the GVWR to arrive at the cargo weight ~~rating~~ of your truck. ■
- To determine the front gross axle weight rating (GAWR) of your vehicle, select the lowest of the front tire ~~weight~~ carrying load capacities and multiply by 2. This will be the front GAWR.
- The rear GAWR is computed in the ~~same~~ manner. Select the lowest of the rear tire or rear spring load capacities and multiply by 2.
- Proceed to calculate the center of ~~gravity~~ location using front and rear GAWRs, cargo weight rating, and front and rear weight of truck as ~~determined~~ determined above. Record this information on the C/K Pickup Computation sheet.
- *If any heavier installed or other ~~equipment~~ equipment will reduce the cargo carrying capacity by the weight of the equipment installed, subtract this weight from the available GVWR. If available, drive to a scale and weigh on the front and on the rear wheels separately to determine the axle weights. You will be able to use this actual axle weight rating and not have to add the GVWR for all the test

**TRUCK-CAMPER LOADING
C/K PICKUPS
WORKSHEET-CARGO WEIGHT RATING**

1. **Model GVWR** _____

2. **Model Weights:**

FRONT _____

REAR _____

3. **Chassis Equipment selected
to meet GVWR requirements:**

	Load Capacity*		
Tires: Front (_____	_____	_____
Rear (_____	_____	_____
Springs: Front	_____	_____	_____
Rear	_____	_____	_____

4. **Other factory-installed options:**

.....	_____	_____
.....	_____	_____
.....	_____	_____
.....	_____	_____
.....	_____	_____
.....	_____	_____
.....	_____	_____
.....	_____	_____
.....	_____	_____
.....	_____	_____

TOTALS _____

5. **Front and Rear Weight:**

5a. **Vehicle sub-total weight** (add front and rear weights) _____

5b. **Add 50 lbs for all models** _____

5c. **Adjusted total vehicle weight:** _____

6. **Vehicle GVWR:** _____

Adjusted total vehicle weight = _____

Cargo Weight Rating = _____

Record on page 4.

7. **Gross Axle Weight Rating:**

	LOAD CAPACITY	AXLE CAPACITY	GROSS AXLE WEIGHT RATING (LOWEST VALUE OF AXLE CAPACITIES)
A Front:			
1. Springs	_____ =	_____	_____
2. Tires	_____ =	_____	
B Rear:			
1. Springs	_____ =	_____	_____
2. Tires	_____ =	_____	

* Load capacity is the rating in pounds for each tire (not tire size).

TRUCK - CAMPER LOADING

S/T-10/15 MODELS

INSTRUCTIONS

VEHICLE SELECTION AND WEIGHT ANALYSIS

1. You must order as a minimum the RPO C3A option (1500 lbs. Payload Package) on a S/T-10803 (117.9" WB) model if you intend on using a slide-in camper on your S/T-10/15 Pickup Truck.
2. From the S Pickup section of the General Motors Light-Duty Truck Data Book, record the front and rear model weights of your vehicle on the S/T-10/15 computation sheet, page 9.
3. List all the factory-installed options including tires you desire with their front and rear weights on the S/T-10/15 Pickup computation sheet.
4. Total the front and rear weights of vehicle model and options to arrive at the total front and rear weight of the vehicle.*
5. Add the cargo weight rating (1050 lbs.) to the total front and rear weights of the vehicle to arrive at the vehicle GVWR.
6. Determine the Gross Axle Weight Ratings (GAWRs) of your selected vehicle as follows:
 - a. Front GAWR is shown on computation sheet.
 - b. Rear GAWR is computed by multiplying the load capacity of the tire selected by 2 and comparing to the value specified for rear axle rating. Select the lowest value of either the rear tire or rear axle capacity.
7. Proceed to calculate the center of gravity location using front and rear GAWRs, Cargo Weight Rating, and front and rear weight of truck as determined above. Record this information on the S/T-10/15 Pickup computation sheet.

*If a vehicle is available, drive to a scale and weigh on the front and on the rear wheels separately to determine the axle loads. You may then be able to use your actual cargo weight and distribution to determine GVWR for the S/T truck.

With RPO AYC (Bucket Seats) Cargo Weight Rating is 1000 lbs.

Note: The addition of any dealer-installed or other accessories will reduce the cargo-carrying capacity by the weight of the equipment installed.

**TRUCK - CAMPER LOADING
S/T-10/15 MODELS**

WORKSHEET - VEHICLE GVWR AND GROSS AXLE WEIGHT RATINGS

1. Model ~~S/T10E02~~ with C3A

2. Model Weight: FRONT _____ REAR _____

3. Other factory installed options:

.....
.....
.....
.....
.....
.....
.....
.....
.....
TOTALS

4. Front and Rear Weight:

- 4a. Vehicle ~~total~~ weight (add front and rear weight): _____
- 4b. Add 50 ~~lbs.~~ for all models _____ -50
- 4c. Adjusted ~~total~~ vehicle weight: _____

5. Vehicle GVWR:

- 5a. Adjusted ~~total~~ vehicle weight _____
- 5b. Cargo ~~Weight~~ Rating _____ 1050*
- 5c. Vehicle ~~GVWR~~ _____

6. Gross Axle ~~Weight~~ Rating:

	LOAD CAPACITY*	AXLE CAPACITY	GROSS AXLE WEIGHT RATING (LOWEST VALUE OF AXLE CAPACITIES)
A. Front:			**
B. Rear:			
1. Axle		▲	
2. Tires		+ 0 =	

*With RPO AV5 ~~Barrier~~ Seats cargo weight rating is 1000 lbs.
 **Load capacity is the rating in pounds for the GVWR.
 *E 4WD Models - 2500 ▲ 4WD Models - 2100
 ▲ S 4WD Models - 2500 ▲ 4WD Models - 2100

TRUCK - CAMPER LOADING

MODEL CODES AND DIMENSIONS

SERIES	MODEL NUMBER	PICKUP BOX LENGTH	PICKUP STYLE	WB	"C"
2-WHEEL-DRIVE REGULAR CAB MODELS					
340 18	310803	7'	Fleetside/Wideside E63	112.9"	42.40"
340 1800	310703	8.5'	Fleetside/Wideside E63	117.5"	43.33"
			Stepside/Fenderside E62	117.5"	43.33"
350 18	310903	8'	Fleetside/Wideside E63	131.5"	44.16"
			Stepside/Fenderside E62	131.5"	44.16"
350 1800	330903	8'	Fleetside/Wideside E63	131.5"	44.16"
			Stepside/Fenderside E62	131.5"	44.16"
4-WHEEL-DRIVE REGULAR CAB MODELS					
440 18	310803	7'	Fleetside/Wideside E63	112.9"	42.40"
			Stepside/Fenderside E62	117.5"	43.33"
440 1800	330903	8'	Fleetside/Wideside E63	131.5"	44.16"
			Stepside/Fenderside E62	131.5"	44.16"
490 1800	330903	8'	Fleetside/Wideside E63	131.5"	44.16"
			Stepside/Fenderside E62	131.5"	44.16"
BONUS CAB MODELS					
720 18	330943	8'	Fleetside/Wideside E63 & YG41	164.5"	44.22"
730 18	330943	8'	Fleetside/Wideside E63 & YG41	164.5"	44.22"
730 1800	330943	8'	Fleetside/Wideside E63 & YG41	164.5"	44.22"
CREW CAB MODELS					
100 18	330943	8'	Fleetside/Wideside E63 & AS3	164.5"	44.22"
110 18	330943	8'	Fleetside/Wideside E63 & AS3	164.5"	44.22"
110 1800	330943	8'	Fleetside/Wideside E63 & AS3	164.5"	44.22"

FLEETSIDE/WIDESIDE

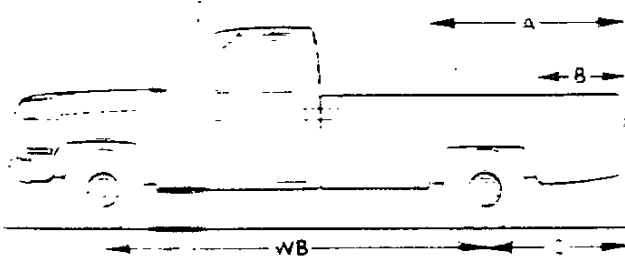

STEPSIDE/FENDERSIDE

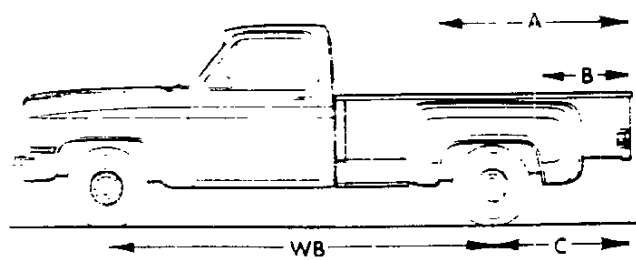

BONUS CAB AND CREW CAB

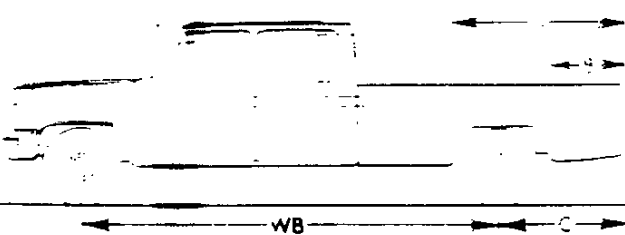

S/T-10/15 PICKUP

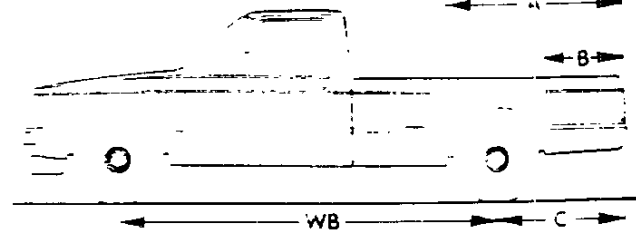

TRUCK - CAMPER LOADING

CALCULATIONS TO DETERMINE FORWARD (A) AND REARWARD (B) LOCATION OF CENTER OF GRAVITY FOR CARGO WEIGHT RATING

Calculations for Dimension A

$$A = \frac{\text{Front GAWR} - 1.05 \times \text{Front Weight of Truck}}{\text{Cargo Weight Rating}} \times \text{W.B.} + C$$

Enter Front GAWR _____

Subtract Front Weight of Truck x 1.05
Answer _____

Divide Answer by Cargo Weight
Answer _____

Multiply Answer by Wheelbase
(See Chart on Page 10)
Answer _____

Add C Dimension to Answer
(See Chart on Page 10) _____

Dimension A = _____

Note: If "A" is greater than pickup box length, use box length for "A" dimension.

Calculations for Dimension B

$$B = 1 - \frac{\text{Rear GAWR} - 1.1 \times \text{Rear Weight of Truck}}{\text{Cargo Weight Rating}} \times \text{W.B.} - C$$

Enter Rear GAWR _____

Subtract Rear Weight of Truck x 1.1
Answer _____

Divide Answer by Cargo Weight
Answer _____

Subtract Answer from 1.000 _____

Multiply Answer by Wheelbase
Answer _____

Add C Dimension to Answer

Dimension B = _____

Note: If "B" dimension is negative, use 0 (zero) for "B" dimension.

Record dimension A and B on page 3.

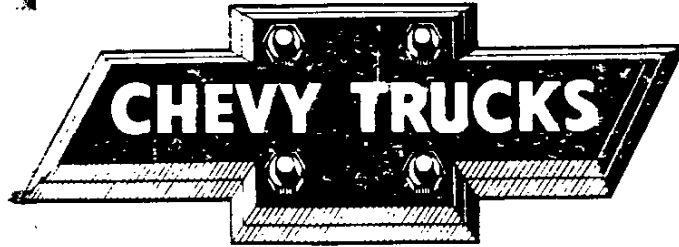

CHEVROLET MOTOR DIVISION
GENERAL MOTORS CORPORATION
WARREN, MICHIGAN 48090



GMC TRUCK & COACH OPERATIONS
GENERAL MOTORS CORPORATION
PONTIAC, MICHIGAN 48058