

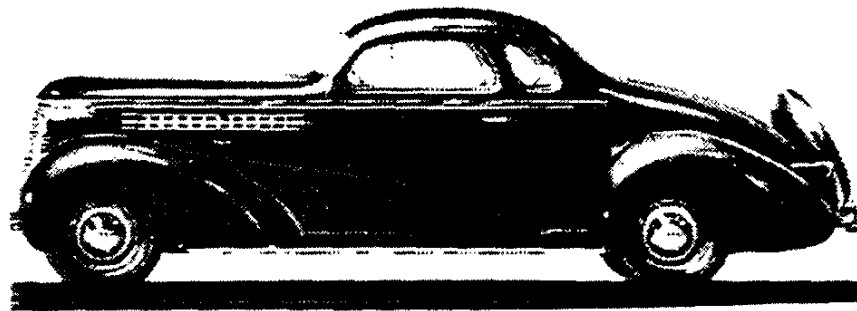

# CHEVROLET



1938 Chevrolet. Master Deluxe. sport coupe. HAC

**1938**

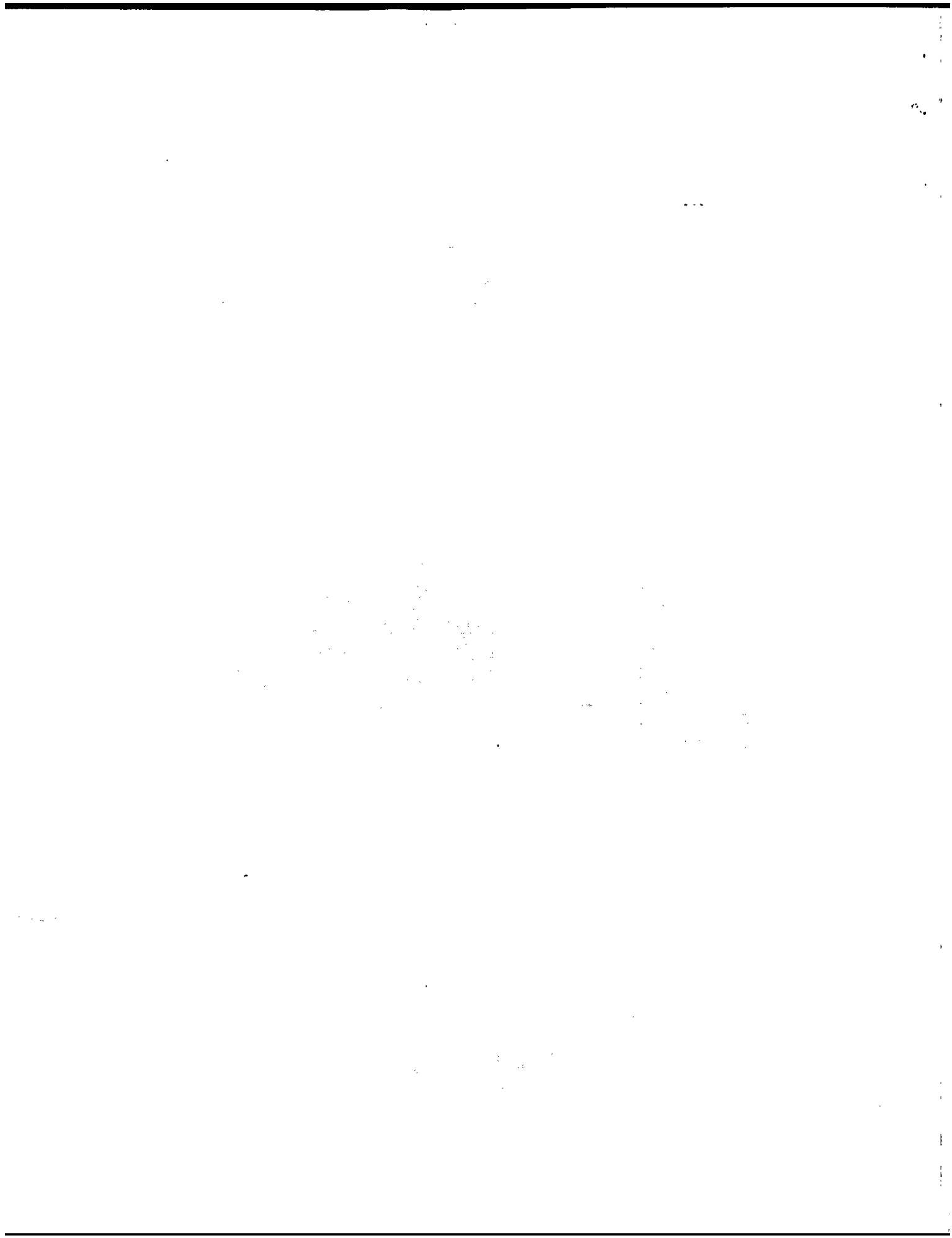

**CHEVROLET**  
**1938**  
**SPECIFICATIONS**

ISSUED TO

---

---

Prepared  
by  
**CHEVROLET—CENTRAL OFFICE**  
**ENGINEERING DEPARTMENT**  
Division of General Motors Corporation  
Detroit, Michigan

Lithographed in U. S. A.

# CHEVROLET 1938 SPECIFICATIONS









## CONTENTS

Title Page .....	1	REAR DRIVE SYSTEM	
Introductory Letter .....	2	Rear Axle .....	33
Contents .....	3	Universal Joints & Propeller Shafts .....	34
<b>MODEL SYMBOLS</b>			
All Models .....	4	<b>BRAKES</b>	
<b>VEHICLE TYPE SYMBOLS</b>			
Passenger Cars .....	5	Brakes, Brake Hydraulic Data .....	35
Commercial Cars, HALF & 3/4 Ton Trucks .....	6	<b>ENGINE</b>	
ONE Ton, 1-1/2 Ton Trucks & School Bus .....	7-8	General Data .....	36
<b>UNIT SERIAL NUMBERS</b>			
All Models .....	9	Passenger Car Power & Torque .....	37
<b>VEHICLE WEIGHTS</b>			
Passenger cars .....	10	Truck Power & Torque .....	38
HALF, 3/4, ONE Ton Trucks & School Bus .....	11	RPM & Piston Speeds - Pass. & HALF Ton .....	39
1-1 2 Ton Trucks .....	12	RPM & Piston Speeds - 3/4 & ONE Ton .....	40
<b>PASSENGER CAR EXTERIOR DIMENSIONS</b>			
All body types .....	13	RPM & Piston Speeds - 1-1/2 Ton Trucks, School Bus .....	41
<b>PASSENGER CAR BODY DIMENSIONS</b>			
Interior Dimensions - Sedan Type Bodies .....	14	Pistons, Connecting Rods .....	42
Luggage Space Dimensions .....	15	Crankshaft, Camshaft .....	43
Interior Dimensions - Coupes & Cabriolet .....	16	Valves, Cylinder Head .....	44
<b>TRUCK BODY DIMENSIONS</b>			
Seat Dimensions, Cab Exterior Dimensions .....	17	Lubrication, Cooling .....	45
Panel Type Trucks .....	18	Fuel System, Exhaust System .....	46
Carryall Suburban, Canopy Express Trucks .....	19	Electrical Equipment .....	47-48
Pickup Trucks .....	20	Power Plant Mountings .....	48
Stake Trucks .....	21-22	<b>CLUTCH</b>	
<b>TRUCK CHASSIS DIMENSIONS</b>			
All Trucks & School Bus .....	22-23	All Models .....	49
<b>TRUCK COWL DIMENSIONS</b>			
Flat-Face Cowl, Cowl With Windshield .....	24	<b>TRANSMISSION</b>	
<b>FRAMES</b>			
Passenger Cars & Half Ton Trucks .....	25	All Models .....	50
3/4, ONE, 1-1/2 Ton Trucks & School Bus .....	26	<b>STEERING</b>	
<b>SUSPENSION</b>			
Master Deluxe Knee Action .....	27	All Models .....	51
Front Axle - Front Wheel Alignment .....	28	<b>WHEELS AND TIRES</b>	
Front Springs .....	29-30	All Models .....	52
Rear Springs .....	31-32	Tires Available, Tire Ratings-1-1/2 Ton Trucks .....	53
Shock Absorbers & Ride Stabilizer .....	32	<b>BATTERY AND LIGHTS</b>	
<b>INDEX</b>			
INDEX .....			
59-6			

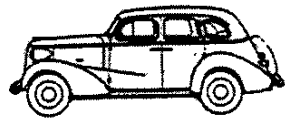
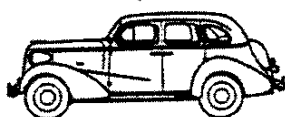
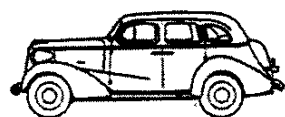
10-16-37, 1-21-38 - Page revised to include Taxicab and School Bus Chassis.

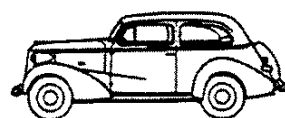
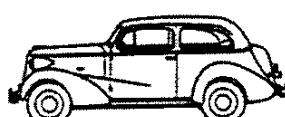
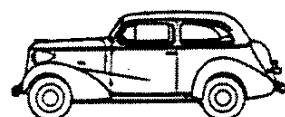
MODEL SYMBOLS		
VEHICLE TYPE	MODEL DESCRIPTIONS	SYMBOLS
Passenger Cars	Master Deluxe 112-1/4" Wheelbase DMAS - Abbreviation	HA
	Master 112-1/4" Wheelbase MAS - Abbreviation	HB
	Taxicab 127" Wheelbase TAXI - Abbreviation	O-18
Commercial Type Trucks	Half Ton 112" Wheelbase	Master HC
	3/4 Ton 122-1/4" Wheelbase	Master HD
	One Ton 122-1/4" Wheelbase	Master HE
1-1/2 Ton Utility Type Trucks	131-1/2" Wheelbase Regular tires Single rear wheels	Master TA
	131-1/2" Wheelbase Regular tires Dual rear wheels	Master TB
	131-1/2" wheelbase Extra heavy duty tires Dual rear wheels	Master Special TB
	157" Wheelbase Regular tires Single rear wheels	Master TC
	157" Wheelbase Regular tires Dual rear wheels	Master TD
	157" Wheelbase Extra heavy duty tires Dual rear wheels	Master Special TD
	School Bus Chassis	201" Wheelbase Regular tires Dual rear wheels

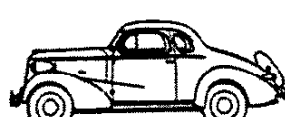

10-15-37, 1-21-38 - Taxicab and School Bus Chassis model symbols added.

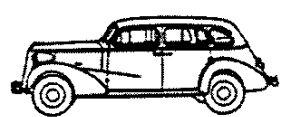
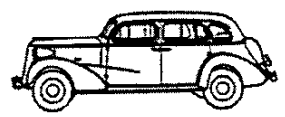





TYPE SYMBOLS—PASSENGER CARS—112¼' WHEELBASE			
MASTER DELUXE		MASTER	
CHASSIS WITH COWL & WINDSHIELD	Chassis Symbol PCH	CHASSIS WITH COWL & WINDSHIELD	Chassis Symbol PCH
			
For mounting bodies other than Chevrolet		For mounting bodies other than Chevrolet	
SEDAN	Symbol SED	SEDAN	Symbol SED
			
5 passenger, 4 door closed body		5 passenger, 4 door closed body	
CLUB SEDAN (SPORT SEDAN)	Symbol CSED	CLUB SEDAN (SPORT SEDAN)	Symbol CSED
			
5 passenger, 4 door closed body with trunk		5 passenger, 4 door closed body with trunk	
COACH	Symbol COA	COACH	Symbol COA
			
5 passenger, 2 door closed body		5 passenger, 2 door closed body	
TOWN SEDAN	Symbol TSED	TOWN SEDAN	Symbol TSED
			
5 passenger, 2 door closed body with trunk		5 passenger, 2 door closed body with trunk	
COUPE 2 (BUSINESS COUPE)	Symbol CPE2	COUPE 2 (BUSINESS COUPE)	Symbol CPE2
			
2 passenger closed body-5 windows		2 passenger closed body-5 windows	
SPORT COUPE	Symbol SCPE	CABRIOLET	Symbol CBL
			
2 passenger closed body with rumble seat-5 windows		2 passenger convertible body with rumble seat	



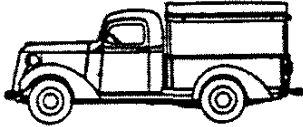

TYPE SYMBOLS—TAXICABS—127' WHEELBASE			
PLAIN BACK TAXI	Symbol TACA	TAXI WITH TRUNK	Symbol TCAT
			
6 passengers & driver - No trunk		6 passengers & driver - Built in trunk	

10-15-37, 1-21-38 - Taxicab type symbols added.

## VEHICLE TYPE SYMBOLS

TYPE SYMBOLS—COMMERCIAL CARS—112¼' WHEELBASE (ON MASTER PASSENGER CHASSIS)			
COUPE PICKUP BOX	Box Symbol CPB	SEDAN DELIVERY	Car Symbol SDL
			
For mounting in Business Coupe (CPE2)		3-door closed panel delivery body	

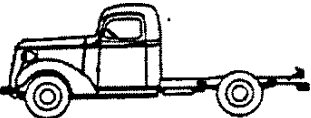
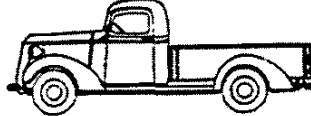

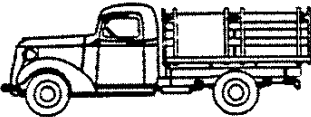

TYPE SYMBOLS—HALF TON TRUCKS—112' WHEELBASE			
CHASSIS WITH FLAT FACE COWL	Symbol GCH	CHASSIS WITH COWL & WINDSHIELD	Symbol-None
			
For mounting bodies other than Chevrolet		For mounting bodies other than Chevrolet	
		CHASSIS WITH CAB	Symbol CCAB
			
		2-door cab-for mounting bodies other than Chevrolet	
PICKUP TRUCK	Truck Symbol CCBX Body Symbol PUB Top Symbol PUEB	PANEL TRUCK	Truck Symbol CPAN Body Symbol CPN
			
2-door cab with pickup box (Top-special equipment)		Panel body with 2 rear doors	
CANOPY EXPRESS TRUCK	Truck Symbol CCAN Body Symbol CXST	CLOSED (CARRYALL) SUBURBAN	Truck Symbol CSUB Body Symbol-Panel type rear doors CCS -Tail gate, upper door CCSG
			
Open side body with steel canopy roof and tail gate		8-passenger closed body with 2 rear doors	







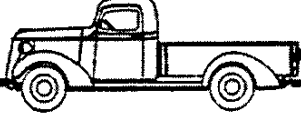

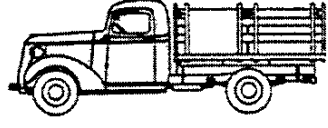
TYPE SYMBOLS—¼-TON TRUCKS—122¼' WHEELBASE			
CHASSIS WITH FLAT FACE COWL	Symbol CLCH	CHASSIS WITH COWL & WINDSHIELD	Symbol-None
			
For mounting bodies other than Chevrolet		For mounting bodies other than Chevrolet	
		CHASSIS WITH CAB	Symbol CLCA
			
		2 door cab-for mounting bodies other than Chevrolet	
PICKUP TRUCK	Truck Symbol CLBX Body Symbol CLPUB	PANEL TRUCK	Truck Symbol CLPAN Body Symbol CLPN
			
2-door cab with pickup box		Panel body with 2 rear doors	
		STAKE TRUCK	Truck Symbol CLST Platform Symbol CLPLA Stakes Symbol CLSTA
			
		2-door cab with stake platform	

10-15-37, 1-21-38 - Page revised.

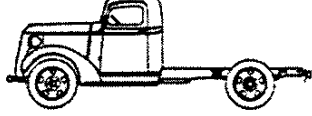
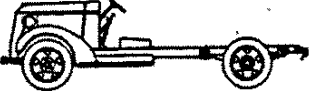
## VEHICLE TYPE SYMBOLS





TYPE SYMBOLS—ONE-TON TRUCKS—122¼' WHEELBASE					
CHASSIS WITH FLAT FACE COWL	Symbol CTCH	CHASSIS WITH COWL AND WINDSHIELD	Symbol-None	CHASSIS WITH CAB	Symbol CTCA
					
For mounting bodies other than Chevrolet		For mounting bodies other than Chevrolet		2 door cab for mounting bodies other than Chevrolet	
PICKUP TRUCK	Truck Symbol CTBX Body Symbol CLPUB	PANEL TRUCK	Truck Symbol CTPAN Body Symbol CLPN	STAKE TRUCK	Truck Symbol CTST Platform Symbol CLPLA Stakes Symbol CLSTA
					
2 door cab with pickup box		Panel body with 2 rear doors		2 door cab with platform & stakes	

TYPE SYMBOLS—1½-TON TRUCKS—131½' WHEELBASE					
CHASSIS WITH FLAT FACE COWL SINGLE REAR WHEELS	Symbol UCH	CHASSIS WITH COWL AND WINDSHIELD SINGLE REAR WHEELS	Symbol-None	CHASSIS WITH CAB SINGLE REAR WHEELS	Symbol UCAB
					
For mounting bodies other than Chevrolet		For mounting bodies other than Chevrolet		2 door cab - for mounting bodies other than Chevrolet	
CHASSIS WITH FLAT FACE COWL DUAL REAR WHEELS	Symbol DCH	CHASSIS WITH COWL AND WINDSHIELD DUAL REAR WHEELS	Symbol-None	CHASSIS WITH CAB DUAL REAR WHEELS	Symbol DCAB
					
For mounting bodies other than Chevrolet		For mounting bodies other than Chevrolet		2 door cab - for mounting bodies other than Chevrolet	
PICKUP TRUCK	Truck Symbol-None Body Symbol UX	PANEL TRUCK	Truck Symbol UPAN Body Symbol UPN		
					
2 door cab with open express body		Panel body with 2 rear doors			
CANOPY EXPRESS TRUCK	Truck Symbol UCAN Body Symbol UXST	STAKE TRUCK	Truck Symbol DST Platform Symbol UPLA Stakes Symbol USTA		
					
Open side body with steel canopy roof and tail gate		2 door cab with platform & stakes			

10-15-37, 1-21-38 - Page revised.

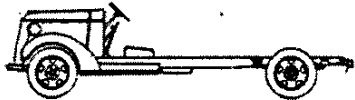
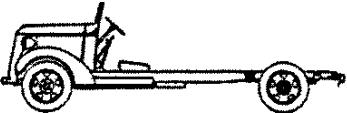
## VEHICLE TYPE SYMBOLS

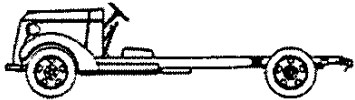
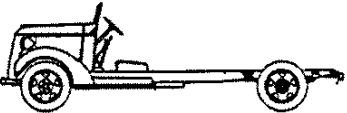
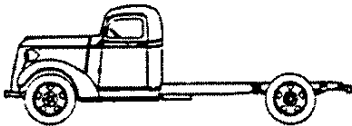
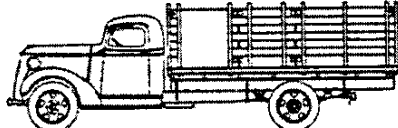
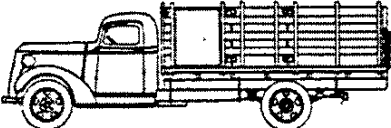
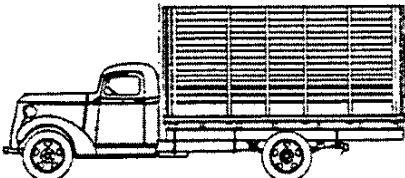
TYPE SYMBOLS—1½-TON TRUCKS—157' WHEELBASE		
<p>CHASSIS WITH FLAT FACE COWL SINGLE REAR WHEELS Symbol ULCH</p>  <p>For mounting bodies other than Chevrolet</p>	<p>CHASSIS WITH COWL AND WINDSHIELD SINGLE REAR WHEELS Symbol-None</p>  <p>For mounting bodies other than Chevrolet</p>	<p>CHASSIS WITH CAB SINGLE REAR WHEELS Symbol ULCA</p>  <p>2 door cab - for mounting bodies other than Chevrolet</p>
<p>CHASSIS WITH FLAT FACE COWL DUAL REAR WHEELS Symbol DLCH</p>  <p>For mounting bodies other than Chevrolet</p>	<p>CHASSIS WITH COWL AND WINDSHIELD DUAL REAR WHEELS Symbol-None</p>  <p>For mounting bodies other than Chevrolet</p>	<p>CHASSIS WITH CAB DUAL REAR WHEELS Symbol DLCA</p>  <p>2 door cab - for mounting bodies other than Chevrolet</p>
<p>STAKE Truck Symbol DLST TRUCK Platform Symbol DPLA Stakes Symbol DSTA</p>  <p>2 door cab with stakes and platform</p>	<p>STAKE Truck Symbol-None EXPRESS Platform Symbol DPLX TRUCK Stakes Symbol DSTX</p>  <p>2 door cab with stakes, platform and tail gate</p>	<p>STOCK Truck Symbol-None RACK Platform Symbol DPLA TRUCK Stakes Symbol DSTO</p>  <p>2 door cab with high stakes and platform body</p>

**TYPE SYMBOL — SCHOOL BUS CHASSIS  
201' WHEELBASE**

CHASSIS WITH FLAT FACE COWL Symbol SBUS  
DUAL REAR WHEELS

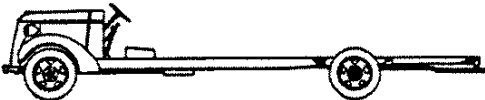

For mounting school bus bodies (No Chevrolet bodies)

10-15-37, 1-21-38 - School Bus chassis added.

# CHEVROLET 1938 SPECIFICATIONS

UNIT SERIAL NUMBERS							
UNITS	PASSENGER CARS			COMMERCIAL TYPE TRUCKS			1-1/2 TON TRUCKS & SCHOOL BUS CHASSIS
	DELUXE	MASTER	TAXI	HALF TON	3/4 TON	ONE TON	
Vehicle	Vehicle serial numbers for each model start at #1001 and continue in numerical sequence. The number is preceded by model letters as follows: HA 1001, HB 1001, TD 1001, etc. (Taxicab & School Bus serial numbers not announced)						
Engine	Numbers	Engine serial numbers start at #1187822 and continue in numerical sequence. The number is preceded by prefix letters designating the various models and plants as shown below.					
	Flint	No prefix		K	AT		T
	Tonawanda	B		KB	ATE		TB
Transmission	Numbers	Transmission serial numbers start with #00001 and continue in numerical sequence up to #99999 for each model and plant as indicated by the prefix letters listed below. Each number is preceded by prefix letters indicating the model and plant. When the numbers reach #99999, the numbers start again with #00001 and are preceded by the next alphabetical prefix letter. Examples: SE changes to SF, MV to MW etc. The letters O and Q are omitted.					
	Toledo	Not made here				TC	
	Saginaw	SE		SN	Not made here		Not made here
	Muncie	MV		Not made	Y		N
Rear Axle	Numbers	Rear axle serial numbers start at #1004705 at the Gear and Axle plant and at #1001 at Tonawanda, each number being preceded by identifying prefix letters as listed below.				The first axle numbers are TS #66938 at Gear and Axle and TSB 1001 at Tonawanda. When numbers reach TS 99999 and TSB 99999, they start again at TT 1001, TTB 1001, etc.	
	Gear & Axle	No Prefix	C	No Prefix F (Opt.)	No prefix	T	TS HTS optional.
	Tonawanda	B	CB	B FB (Opt.)	B	TB	TSB HTSB optional

**SERIAL NUMBER LOCATIONS**

**VEHICLE SERIAL NUMBER**

Stamped on plate under hood on right side of cowl panel. (Taxicab-stamped on top of right side rail behind radiator shell. School Bus-not announced).

**TRANSMISSION SERIAL NUMBER**

Passenger cars & Commercial Type Trucks-Stamped on milled surface of case at rear edge of cover.  
 1-1/2 Ton, School Bus Chassis & Commercial Type Trucks with 4-speed transmission-Stamped on milled surface on back of case, left hand side.

**REAR AXLE SERIAL NUMBER**

Passenger Cars & Commercial Type Trucks-Stamped on front upper surface (rough) of differential carrier.  
 1-1/2 Ton & School Bus Chassis-Stamped on center upper surface (rough) of differential carrier.

CHEVROLET

FISHER

FRONT OF DASH

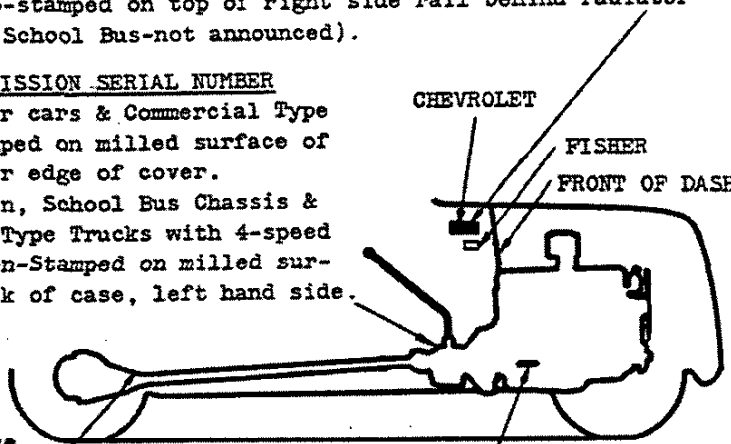

**ENGINE SERIAL NUMBER**

Stamped on milled pad on crankcase to rear of distributor on right side of engine.

10-15-37, 1-21-38 - Taxicab and School Bus data added; Truck engine prefix letters revised.

## PASSENGER CAR WEIGHTS

BODY TYPES	MASTER DELUXE		MASTER	
	Shipping	Curb	Shipping	Curb
Chassis with Cowl and Windshield(Short Sill)	2170#	2290#	2095#	2215#
On front wheels	1335#	1350#	1280#	1295#
On rear wheels	835#	940#	815#	920#
Sedan	2915#	3035#	2840#	2960#
On front wheels	1480#	1495#	1425#	1440#
On rear wheels	1435#	1540#	1415#	1520#
Sport Sedan	2940#	3060#	2845#	2965#
On front wheels	1500#	1515#	1415#	1430#
On rear wheels	1440#	1545#	1430#	1535#
Coach	2900#	3020#	2795#	2915#
On front wheels	1490#	1505#	1410#	1425#
On rear wheels	1410#	1515#	1385#	1490#
Town Sedan	2915#	3025#	2825#	2945#
On front wheels	1490#	1505#	1410#	1425#
On rear wheels	1425#	1530#	1415#	1520#
Business Coupe	2840#	2980#	2770#	2910#
On front wheels	1520#	1570#	1445#	1495#
On rear wheels	1320#	1410#	1325#	1415#
Sport Coupe	2855#	2975#		
On front wheels	1495#	1510#	- - -	- - -
On rear wheels	1360#	1465#		
Cabriolet			2790#	2910#
On front wheels	- - -	- - -	1435#	1450#
On rear wheels			1355#	1460#
Coupe Pickup			2945#	3085#
On front wheels	- - -	- - -	1500#	1550#
On rear wheels			1445#	1535#
Sedan Delivery			2835#	2975#
On front wheels	- - -	- - -	1420#	1470#
On rear wheels			1415#	1505#

BODY TYPES	TAXICAB WITH DRIVER'S SEAT		CONVERSION TO 7-PASSENGER SEDAN	
	Shipping	Curb	Shipping	Curb
Sedan (Plain Back)	3180#	3315#	3155#	3290#
On front wheels	1580#	1600#	1615#	1635#
On rear wheels	1600#	1715#	1540#	1655#
Sedan (with Trunk)	3205#	3340#	3180#	3315#
On front wheels	1580#	1600#	1615#	1635#
On rear wheels	1625#	1740#	1565#	1680#

### WEIGHT CONDITIONS

SHIPPING WEIGHT - Total weight of car with all regular equipment, which includes front and rear bumpers, bumper guards on all Master Deluxe cars and the Master Cabriolet, spare wheel and tire (see note), tools, and grease or oil in all units. Also on types with spare tire on out-

side of body, spare tire cover (none on Taxicab) is included. CURB WEIGHT - This is the weight of the empty car ready to drive. It is the shipping weight plus gasoline and water.

NOTE: Spare tire is included in Curb Weight of Taxicab, but not in its Shipping Weight.

10-15-37, 1-21-38 - Production weights, including Taxicab, added.

## VEHICLE WEIGHTS

# CHEVROLET 1938 SPECIFICATIONS

COMMERCIAL TYPE TRUCK WEIGHTS						
CHASSIS AND BODY TYPES	HALF TON TRUCKS		3/4 TON TRUCKS		ONE TON TRUCKS	
	Shipping	Curb	Shipping	Curb	Shipping	Curb
Chassis with flat face cowl	2200#	2350#	2420#	2560#	2575#	2715#
On front wheels	1330#	1390#	1425#	1490#	1475#	1540#
On rear wheels	870#	940#	995#	1070#	1100#	1175#
Chassis and cab	2580#	2720#	2785#	2925#	2950#	3090#
On front wheels	1540#	1625#	1650#	1735#	1700#	1785#
On rear wheels	1040#	1095#	1135#	1190#	1250#	1305#
Chassis, cab and pickup	2805#	2945#	3035#	3175#	3200#	3340#
On front wheels	1525#	1610#	1645#	1730#	1700#	1785#
On rear wheels	1280#	1335#	1390#	1445#	1500#	1555#
Panel truck	3015#	3145#	3280#	3420#	3445#	3585#
On front wheels	1450#	1510#	1605#	1670#	1650#	1715#
On rear wheels	1565#	1635#	1675#	1750#	1795#	1870#
Single unit express	3030#	3160#	- - -	- - -	- - -	- - -
On front wheels	1495#	1555#	- - -	- - -	- - -	- - -
On rear wheels	1535#	1605#	- - -	- - -	- - -	- - -
Carryall Suburban	3295#	3425#	- - -	- - -	- - -	- - -
On front wheels	1480#	1540#	- - -	- - -	- - -	- - -
On rear wheels	1815#	1885#	- - -	- - -	- - -	- - -
Cab and Stake	- - -	- - -	3300#	3440#	3440#	3580#
On front wheels	- - -	- - -	1645#	1730#	1710#	1795#
On rear wheels	- - -	- - -	1655#	1710#	1730#	1785#

### WEIGHT CONDITIONS

SHIPPING WEIGHT - This is the total weight of the truck with all regular equipment which includes front and rear bumpers (except no rear bumper is provided with stake trucks), spare wheel and tire

and carrier, tools, grease or oil in all units. CURB WEIGHT - This is the weight of the empty truck ready to drive. It is the shipping weight plus gasoline and water.

GROSS ALLOWABLE WEIGHTS		
TRUCK	TIRES	WEIGHT
HALF TON	6.00-16-4 ply regular tires or 5.50-18-4 ply optional tires	4400#
	6.00-16-6 ply optional tires or 15" - 6 ply optional tires	4600#
3/4 TON	15" - 6 ply regular tires	5200#
	No optional tires	
ONE TON	7.00-17-6 ply regular tires or regular front tires with optional 7.50-17-8 ply rear tires	5800#

GROSS ALLOWABLE WEIGHT is the maximum weight of the loaded truck. It includes chassis, cab and body (or single unit body), driver, passenger, payload, gasoline and water.

NOTE: Only single rear wheel equipment is available on HALF, 3/4 and ONE TON trucks.

EQUIPMENT WEIGHTS			
	HALF TON	3/4 TON	ONE TON
Cab	460#		
Flat face cowl	78#		
Cowl and windshield	105#		
Pickup box body	230#	260#	
Pickup top and curtains	100#	- -	- -
Carryall Suburban body	1046#	- -	- -
Panel body	928#	943#	
Canopy Express body	890#	- -	- -
Canopy Express screens	60#	- -	- -
Stake platform	- -	370#	
Stake racks	- -	180#	
6.00-16-4 tire and wheel	43-1/4#	- -	- -
5.50-18-4 tire and wheel	51-1/2#	- -	- -
6.00-16-6 tire and wheel	49-3/4#	- -	- -
15" - 6 tire and wheel	61-1/4#	- -	- -
7.00-17-6 tire and wheel			78#
7.50-17-8 tire and wheel			90-1/2#

SCHOOL BUS CHASSIS WEIGHTS			
CHASSIS TYPE	SHIPPING	CURB	GROSS ALLOWABLE WEIGHTS
Chassis with flat face cowl	#	#	
On front wheels	#	#	32 x 6-8 Tires (Dual Rear) . . . . . #
On rear wheels	#	#	32 x 6-10 Optional Tires (Dual Rear) . . . . . #

10-15-37, 1-21-38 - School Bus Chassis weights and Commercial type truck production weights added.

### VEHICLE WEIGHTS

1½-TON UTILITY TYPE TRUCK WEIGHTS								
CHASSIS AND BODY TYPES (REGULAR TIRES)	131-1/2" WHEELBASE				157" WHEELBASE			
	SINGLE REAR WHEELS		DUAL REAR WHEELS		SINGLE REAR WHEELS		DUAL REAR WHEELS	
	Shipping	Curb	Shipping	Curb	Shipping	Curb	Shipping	Curb
Chassis with flat face cowl	3035#	3230#	3120#	3300#	3055#	3250#	3195#	3375#
On front wheels	1675#	1755#	1665#	1745#	1705#	1795#	1735#	1825#
On rear wheels	1360#	1475#	1455#	1555#	1350#	1455#	1460#	1550#
Chassis with cab	3410#	3605#	3485#	3665#	3415#	3610#	3560#	3740#
On front wheels	1895#	1975#	1880#	1960#	1970#	2060#	1960#	2050#
On rear wheels	1515#	1630#	1605#	1705#	1445#	1550#	1600#	1690#
Pickup truck	*3870#	*4065#	- - -	- - -	- - -	- - -	- - -	- - -
On front wheels	1875#	1955#	- - -	- - -	- - -	- - -	- - -	- - -
On rear wheels	1995#	2110#	- - -	- - -	- - -	- - -	- - -	- - -
Panel truck	4035#	4230#	- - -	- - -	- - -	- - -	- - -	- - -
On front wheels	1860#	1940#	- - -	- - -	- - -	- - -	- - -	- - -
On rear wheels	2175#	2290#	- - -	- - -	- - -	- - -	- - -	- - -
Canopy Express truck	4040#	4235#	- - -	- - -	- - -	- - -	- - -	- - -
On front wheels	1865#	1945#	- - -	- - -	- - -	- - -	- - -	- - -
On rear wheels	2175#	2290#	- - -	- - -	- - -	- - -	- - -	- - -
Stake truck	- - -	- - -	*4060#	*4440#	- - -	- - -	*4535#	*4715#
On front wheels	- - -	- - -	1855#	1935#	- - -	- - -	2020#	2110#
On rear wheels	- - -	- - -	2405#	2505#	- - -	- - -	2515#	2605#
Stock Rack truck	- - -	- - -	- - -	- - -	- - -	- - -	*4845#	*5025#
On front wheels	- - -	- - -	- - -	- - -	- - -	- - -	2075#	2165#
On rear wheels	- - -	- - -	- - -	- - -	- - -	- - -	2770#	2860#

\* - These weights are estimated. They will be superseded by production weights when available.

SHIPPING WEIGHT - This is the total weight of the truck with all regular equipment which includes the front bumper, spare wheel and carrier, (No Spare Tire) tools and grease or oil in all units.

CURB WEIGHT - This is the weight of the empty truck ready to drive. It is the shipping weight plus gasoline, water and spare tire.

1½-TON TRUCKS GROSS ALLOWABLE WEIGHTS	
TIRES	WEIGHT
6.00-20-6 front tires with 32 x 6-8 single rear tires. Regular equipment	7600#
32 x 6-10 front and single rear tires maximum single rear equipment.	7900#
6.00-20-6 front and dual rear tires. Regular equipment. Or 7.00-20-8 front and dual rear tires.	9300#
6.50-20-6 or larger front tires with 32 x 6-10 or 7.50-20-8 dual rear tires and auxiliary rear springs.	11,300#
6.50-20-6 or larger front tires with 32 x 6-10 or 7.50-20-8 dual rear tires, auxiliary rear springs and governor. Governor set not to exceed 45 MPH.	13,300#
GROSS ALLOWABLE WEIGHT is the maximum weight of the loaded truck. It includes chassis, cab and body (or single unit body), driver, passenger, payload, gasoline and water.	

1½-TON TRUCKS EQUIPMENT WEIGHTS		
EQUIPMENT	131-1/2"	157"
Cab	460#	
Flat face cowl	78#	
Cowl and windshield	105#	
Pickup box	460#	- -
Panel body	1077#	- -
Canopy Express body	1012#	- -
Canopy Express screens	75#	- -
Stake platform	515#	694#
Stake racks	290#	341#
Stock racks	- -	589#
Express platform	- -	680#
Express racks	- -	376#
2 aux. springs & attachments	75#	
30 x 5-6 tire and wheel	85#	
6.00-20-6 tire and wheel	85#	
6.50-20-6 tire and wheel	90#	
32 x 6-8 tire and wheel	100#	
7.00-20-8 tire and wheel	110#	
32 x 6-10 tire and wheel	125#	
7.50-20-8 tire and wheel	125#	

10-15-37, 1-21-38 - Production weights added.

## VEHICLE WEIGHTS

## PASSENGER CAR EXTERIOR DIMENSIONS

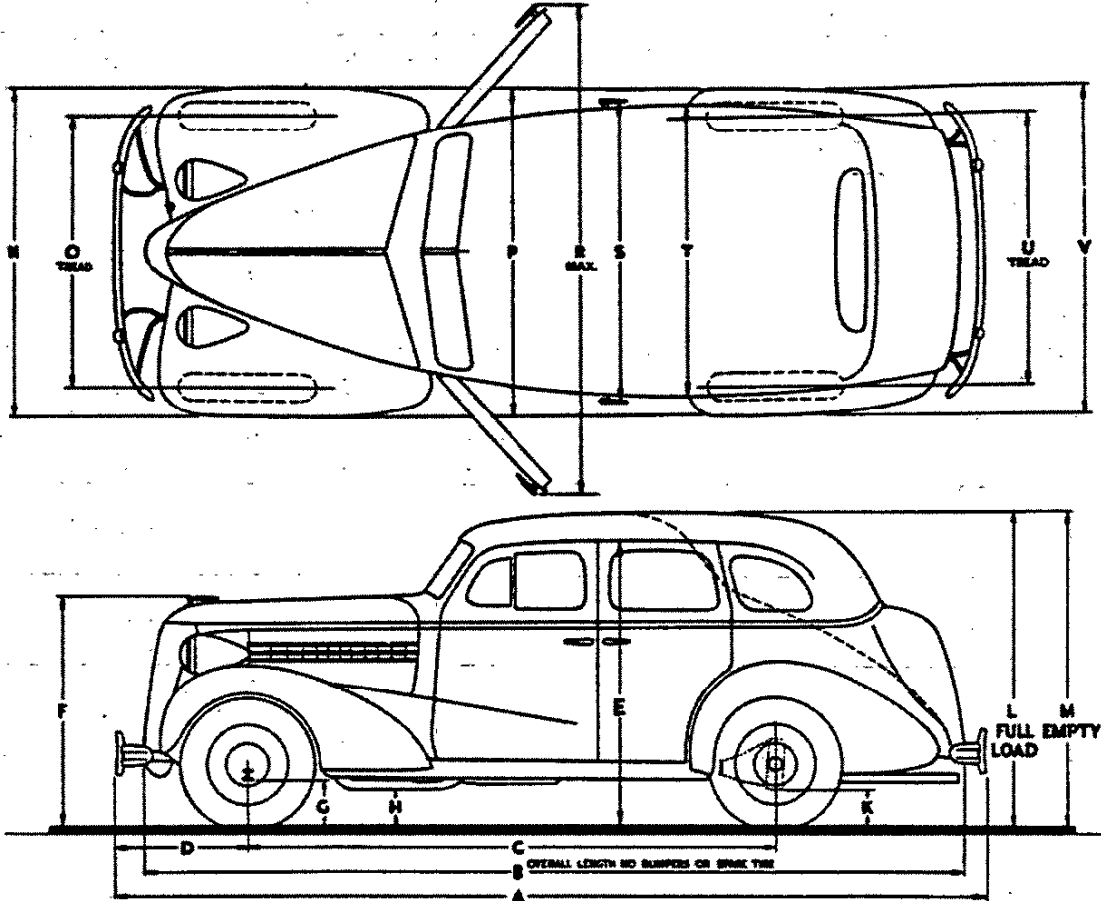

	MASTER DELUXE				MASTER				TAXICAB		
	Sport & Town Sedan	Sedan & Coach	Business Coupe	Sport Coupe	Sport & Town Sedan	Sedan & Coach	Business Coupe	Cabriolet	Sedan	Sedan with Trunk	
A	185-3/16"	187-5/16"	185-3/16"	187-5/16"	184-11/16"	187-1/16"	184-11/16"	187-5/16"	202"	200"	A
B	173-1/4"	171-3/4"			173-1/4"	171-3/4"			186-1/2"	188"	B
C	112-1/4"								127"		C
D	27-13/16"				27-9/16"				27-13/16"		D
E									62-1/2"*		E
F	48-9/16"				50"				49-1/2"		F
G	10-3/8"				8-5/8"				8-5/16"		G
H	8-1/4"				9-3/16"				8-1/4"		H
K	8-1/2"								8"		K
L	66-7/8"	66-1/8"			66-7/8"	66-1/8"	66-1/4"		67-1/2"		L
M	67-3/4"	67-1/4"			68-3/8"	67-1/4"	67-3/8"		69-3/4"		M
N	69-3/4"										N
O	57-1/4"				56-3/8"						O
P	70-1/4"										P
R	120-1/4"	131-1/8"			120-1/4"	131-1/8"			132"		R
R'	139"	None			139"	None		None			R'
S	67-1/4"								66-1/2"		S
T	62-1/2"										T
U	59"								59-1/4"		U
V	70-13/16"										V

Unless otherwise specified, all vertical dimensions are for design load conditions. \* - Empty. 10-15-37, 1-21-38 - Data rearranged. Taxicab added.

## PASSENGER CAR EXTERIOR DIMENSIONS

## PASSENGER CAR BODY DIMENSIONS

### SEDAN & SPORT SEDAN

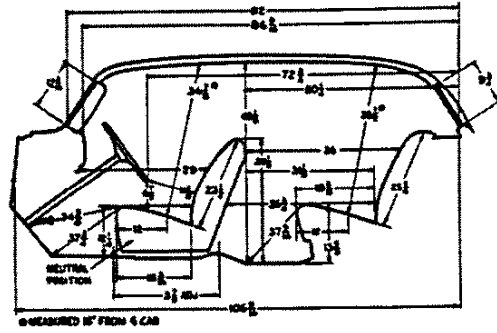
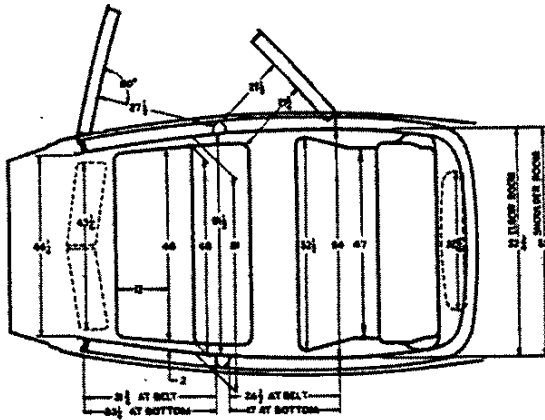

### COACH & TOWN SEDAN

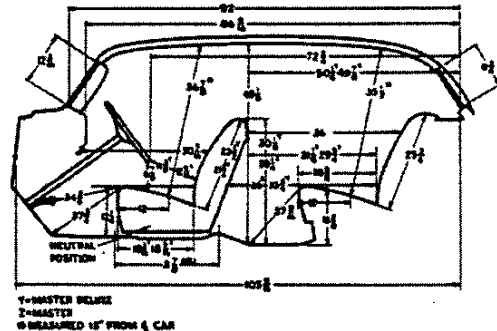
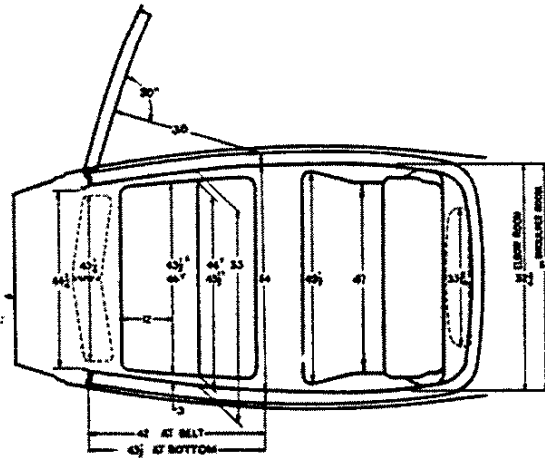

### TAXICAB

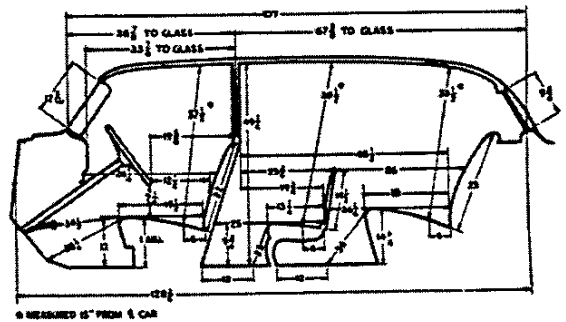
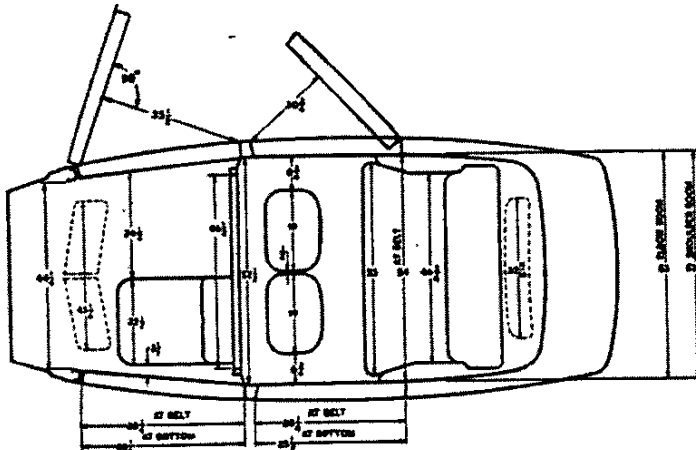

10-15-37, 1-21-38 - Page revised, Taxicab added.

## PASSENGER CAR BODY DIMENSIONS



## PASSENGER CAR LUGGAGE SPACE

SPORT SEDAN, TOWN SEDAN & TAXICAB  
 TRUNK LUGGAGE SPACE  
 CAPACITY - 15 cubic feet

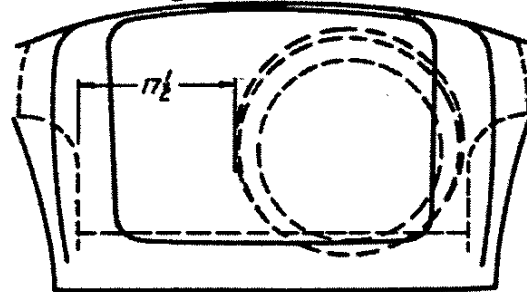
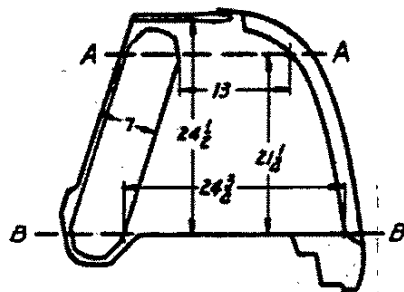
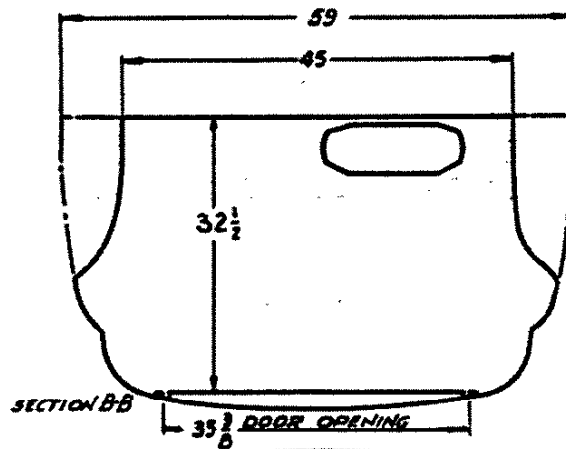
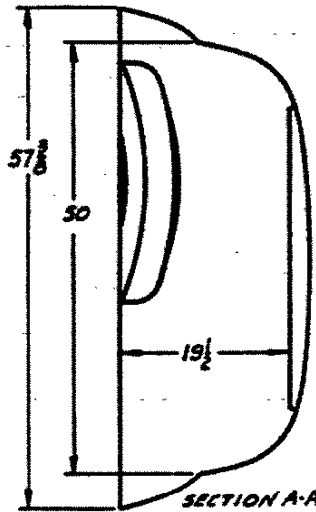

SEDAN, COACH & TAXICAB  
 LUGGAGE SPACE  
 CAPACITY - 13 cubic feet

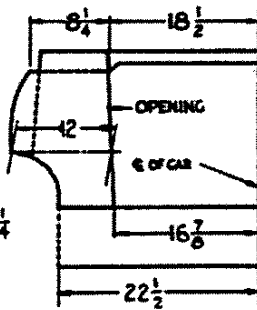
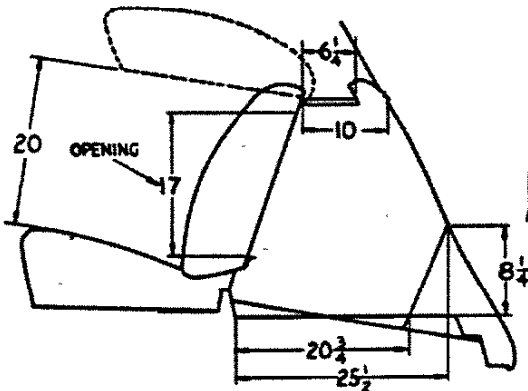

INSTRUMENT PANEL  
 GLOVE COMPARTMENT  
 PASSENGER CARS  
 AND TRUCKS

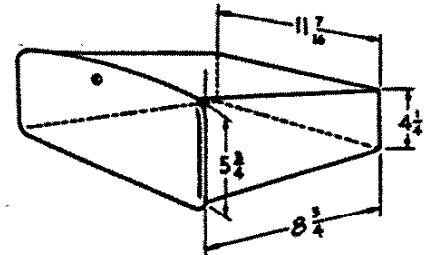

10-15-37, 1-21-38 - Taxicab added.

## PASSENGER CAR BODY DIMENSIONS

### SPORT COUPE & MASTER CABRIOLET

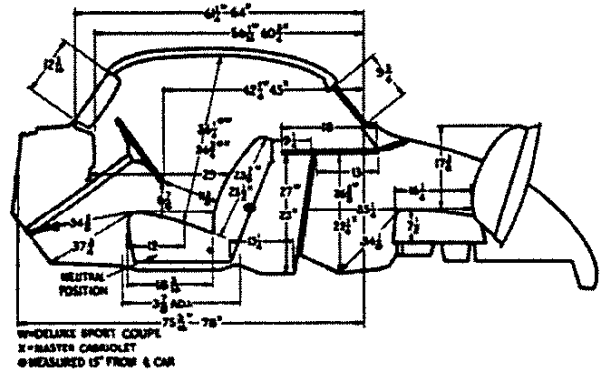
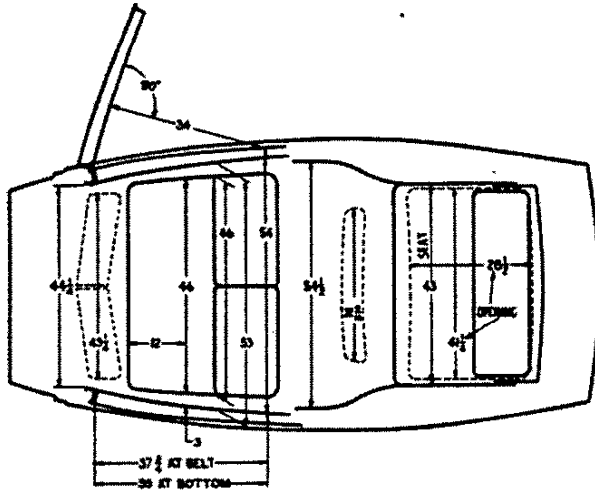

### BUSINESS COUPE

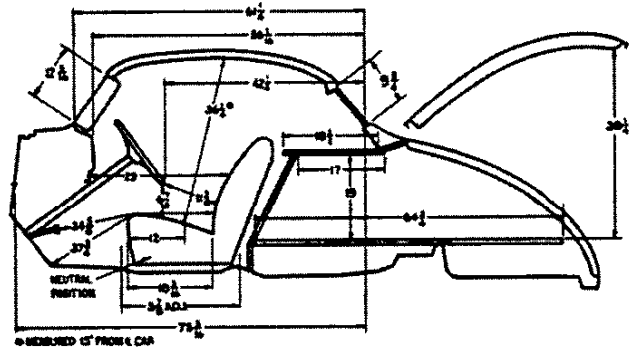
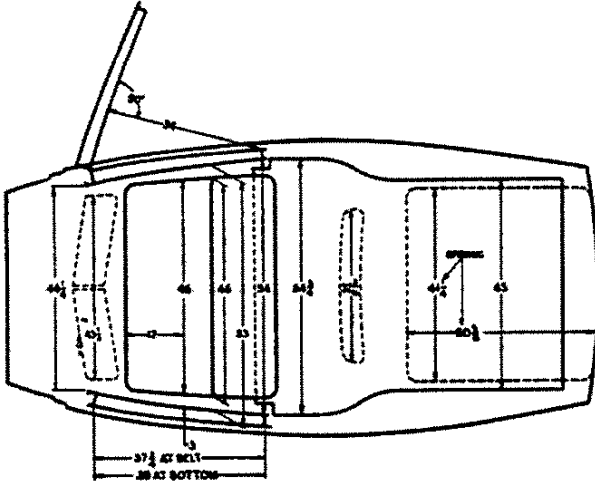

### SEVEN-PASSENGER CONVERSION (TAXICAB)

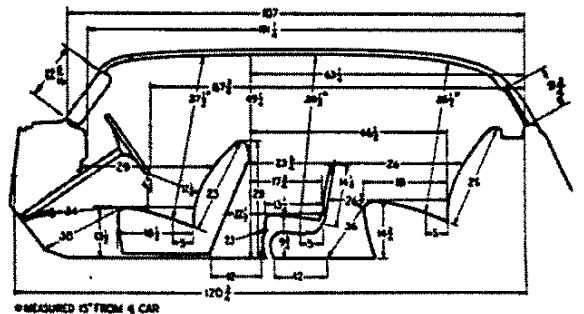
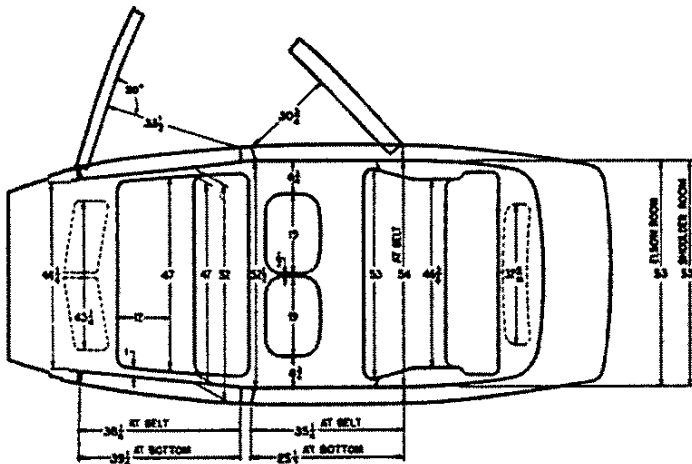

10-15-37, 1-21-38 - Page revised, Seven-Passenger Conversion (Taxicab) added.

## COMMERCIAL CAR AND TRUCK SEAT DIMENSIONS

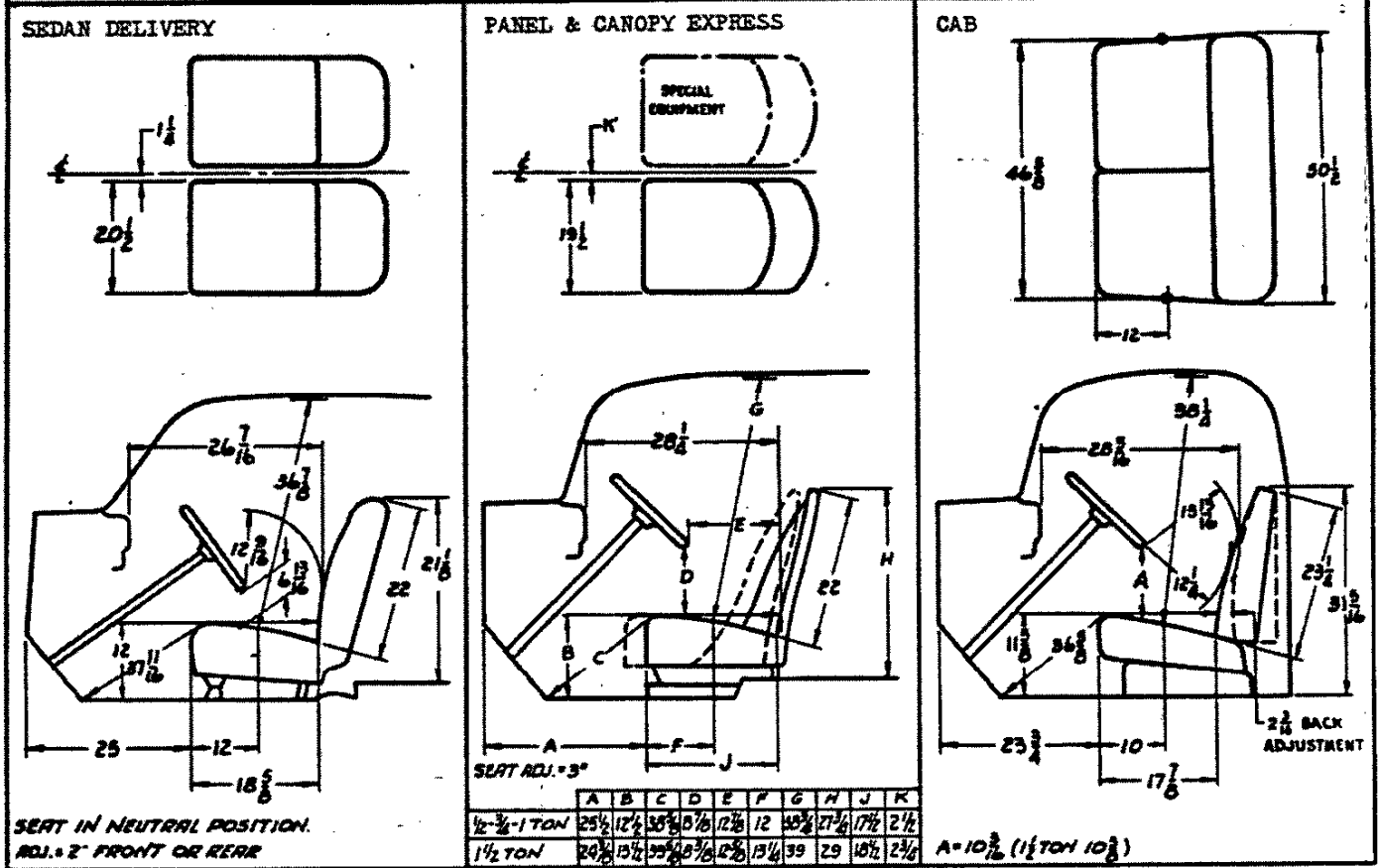

## TRUCK CAB EXTERIOR DIMENSIONS

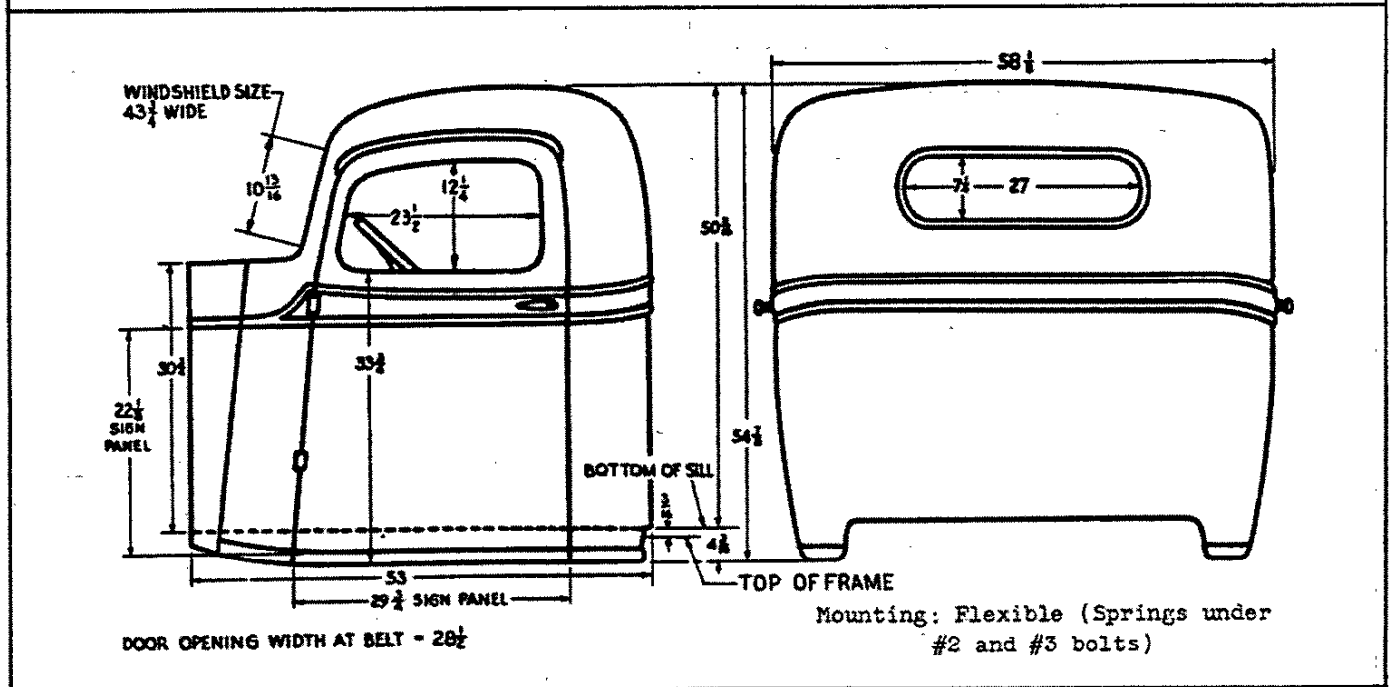

10-15-37, 1-21-38 - Windshield size added.

## TRUCK BODY DIMENSIONS

## PANEL TYPE TRUCK BODY DIMENSIONS

SEDAN DELIVERY  
(ON MASTER PASSENGER  
CHASSIS)

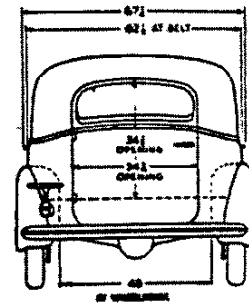
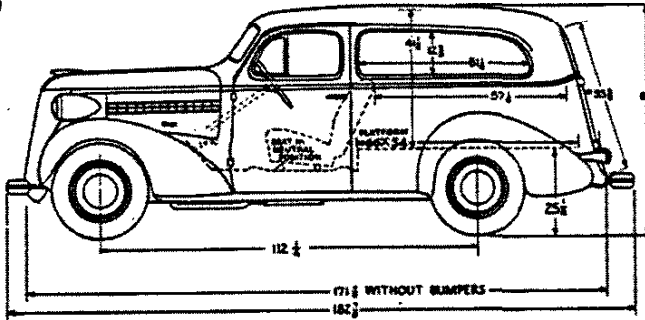

HALF TON PANEL

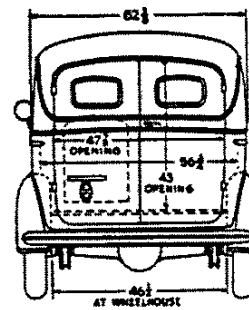
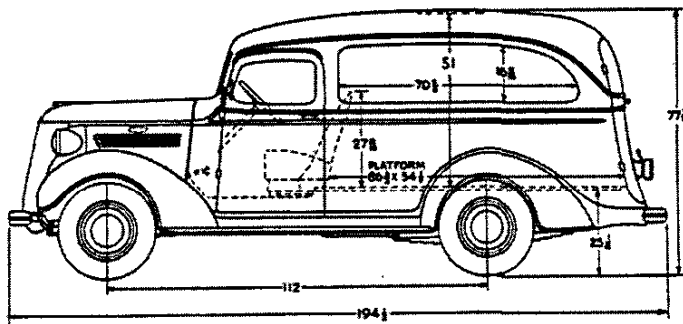

3/4 TON PANEL  
ONE TON PANEL

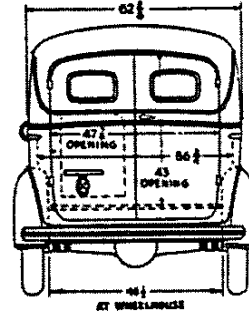
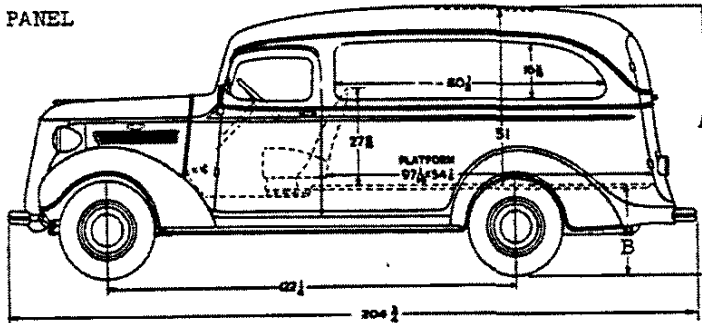

3/4 TON; A = 79-3/8, B = 27-5/16 ONE TON; A = 81-1/16, B = 29

1-1/2 TON PANEL

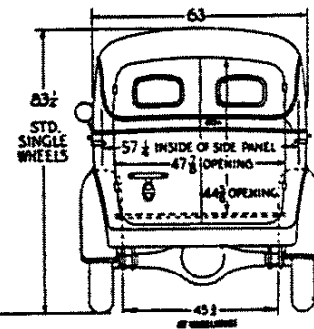
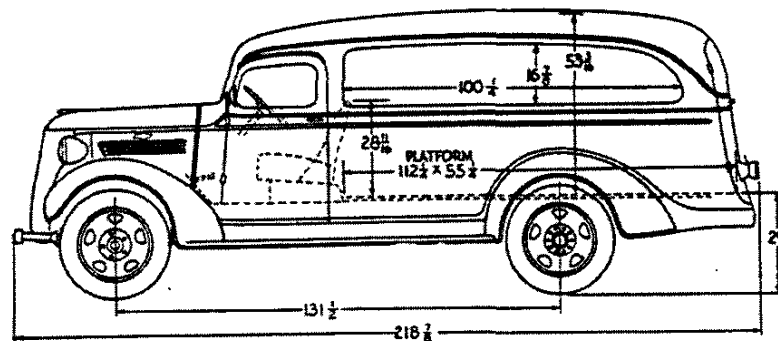

NOTE: Unless otherwise specified, all vertical dimensions are for design load conditions.

## CARRYALL SUBURBAN BODY DIMENSIONS

HALF TON  
CARRYALL SUBURBAN

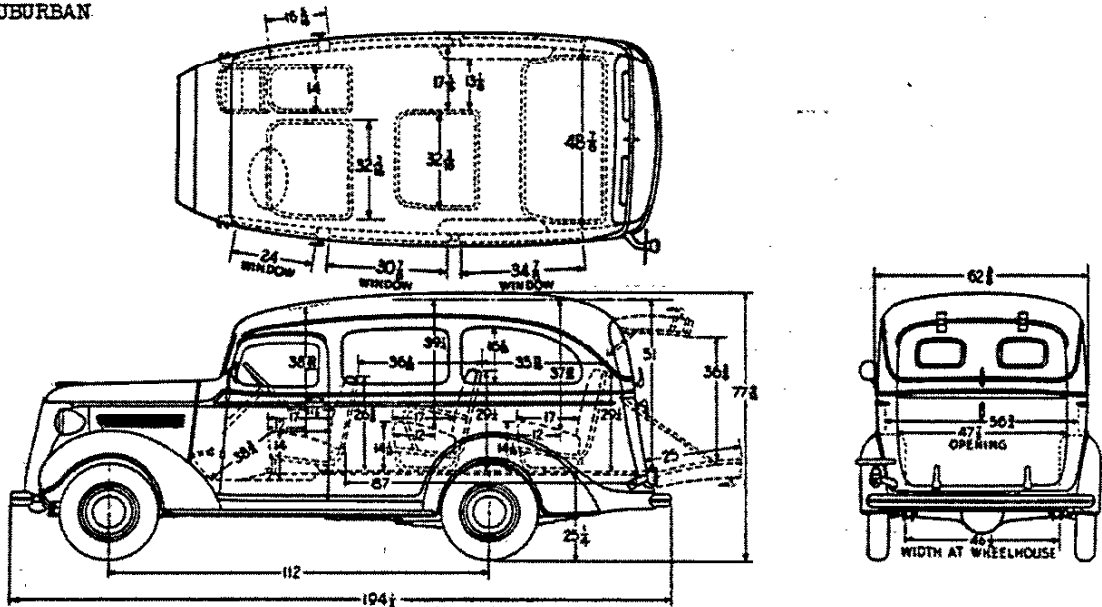

NOTE: Rear doors are optional as shown or as on Half Ton panel truck.

## CANOPY EXPRESS TRUCK BODY DIMENSIONS

HALF TON  
CANOPY  
EXPRESS

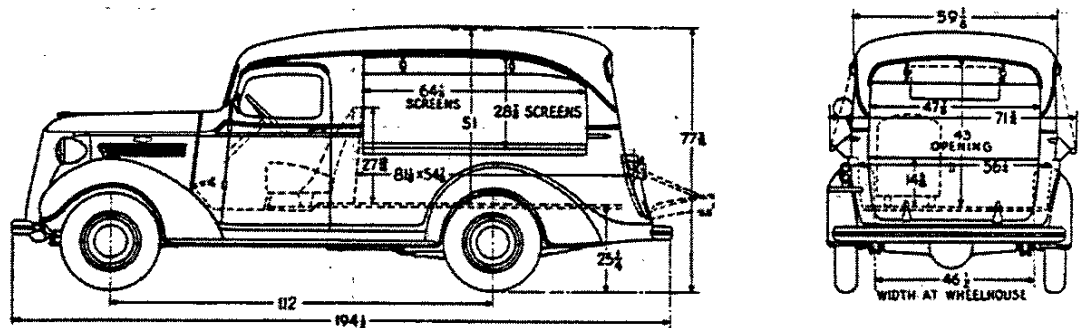

1-1/2 TON CANOPY EXPRESS

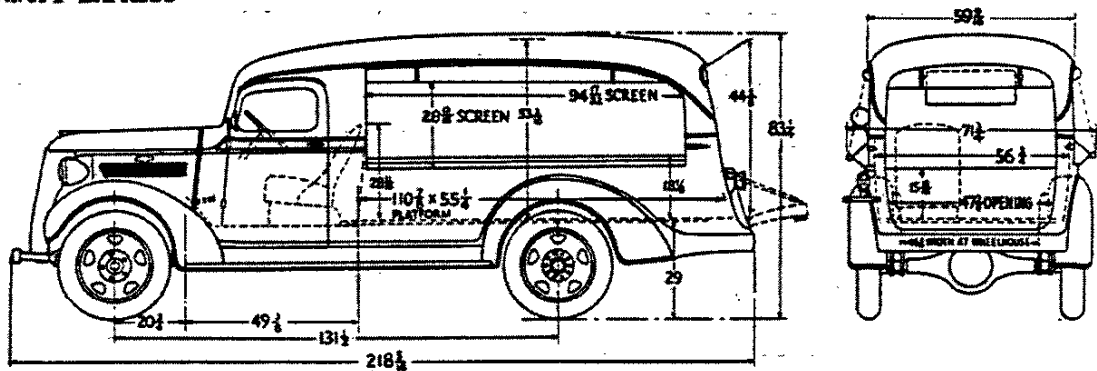

NOTE: Unless otherwise specified, all vertical dimensions are for design load conditions.

10-15-37, 1-21-38 - Half Ton Canopy Express platform redimensioned. Carryall Suburban note revised.

## TRUCK BODY DIMENSIONS

## PICKUP TRUCK BODY DIMENSIONS

COUPE PICKUP  
ON MASTER  
PASSENGER  
CHASSIS

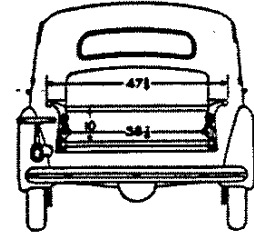
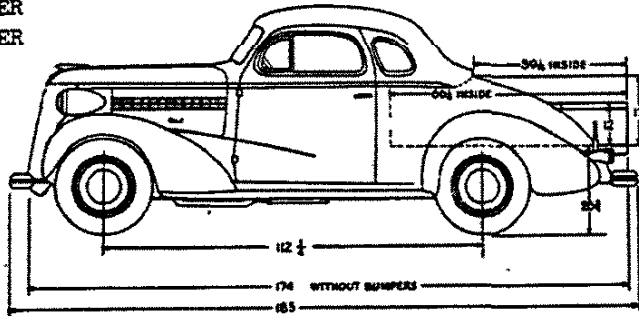

HALF TON  
PICKUP

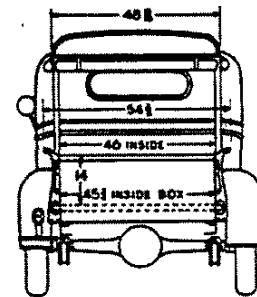
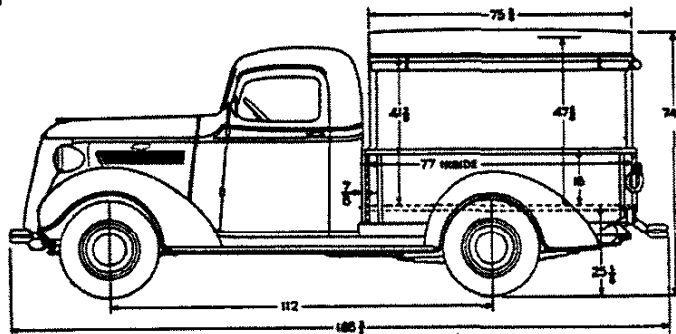

NOTE: Pickup top is special equipment available on this model only.

3/4 TON PICKUP  
ONE TON PICKUP

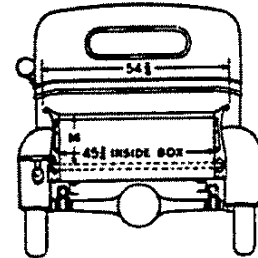
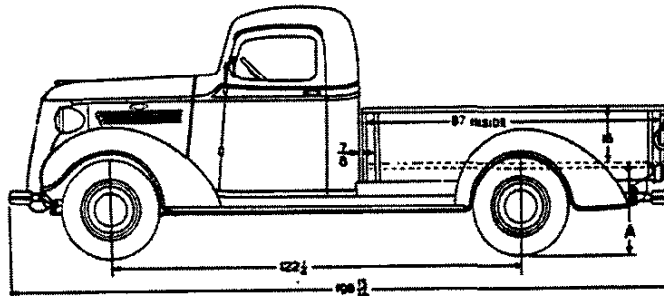

	3/4 TON	ONE TON
A =	27-7/8"	29-9/16"

1-1/2 TON PICKUP  
(ON 131-1/2" W.B. CHASSIS)

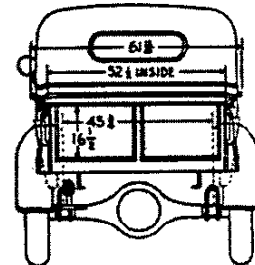
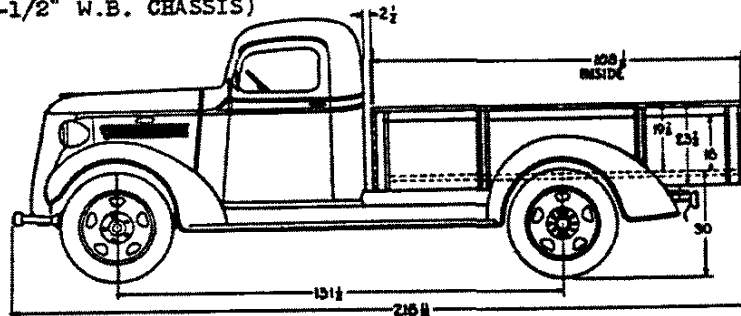

NOTE: Unless otherwise specified, all vertical dimensions are for design load conditions.

## STAKE TRUCK BODY DIMENSIONS

3/4 TON STAKE  
ONE TON STAKE

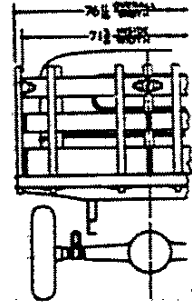
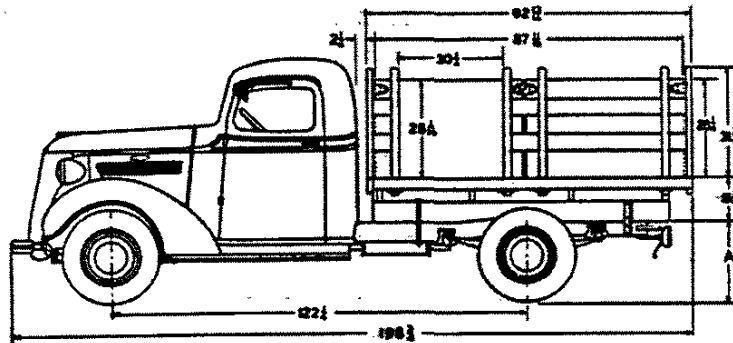

	3/4 TON	ONE TON
A	38-1/16	39-3/4

1-1/2 TON, 131-1/2" W.B. STAKE

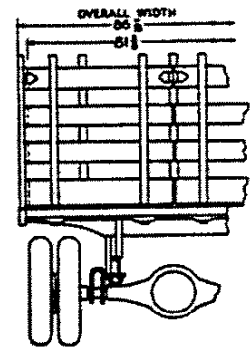
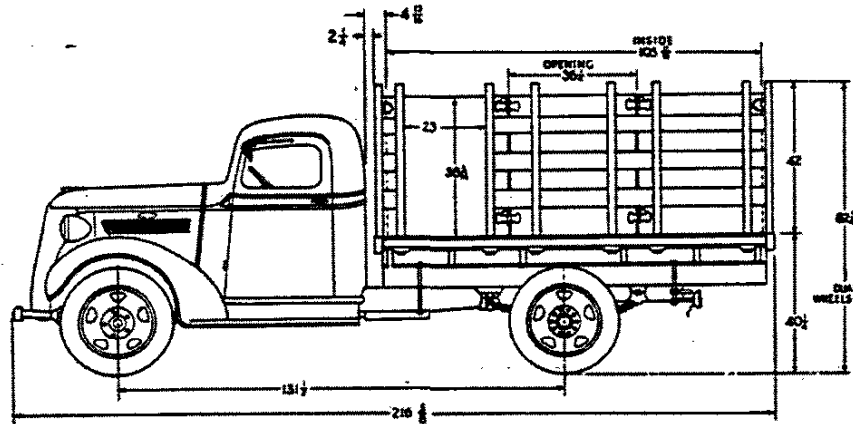

1-1/2 TON, 157" W.B. STAKE

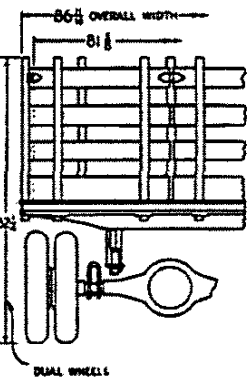
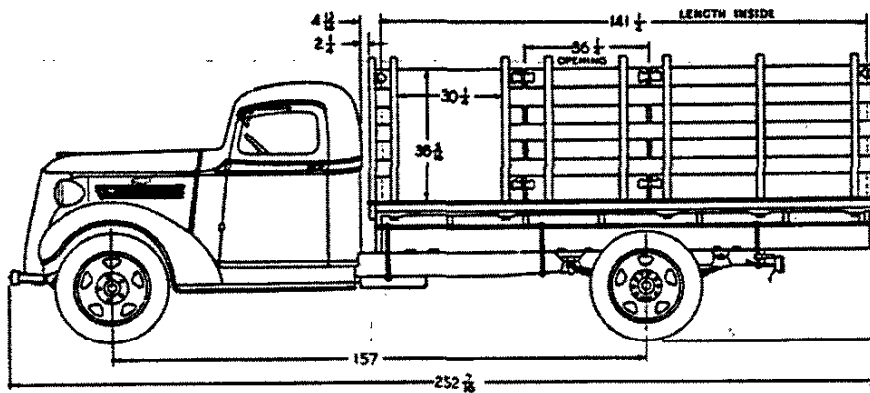

NOTE: Unless otherwise specified, all vertical dimensions are for design load conditions.

10-15-37, 1-21-38 - Illustrations corrected.

## TRUCK BODY DIMENSIONS

## STAKE TRUCK BODY DIMENSIONS—Continued

1-1/2 TON, 157" W.B. STAKE EXPRESS

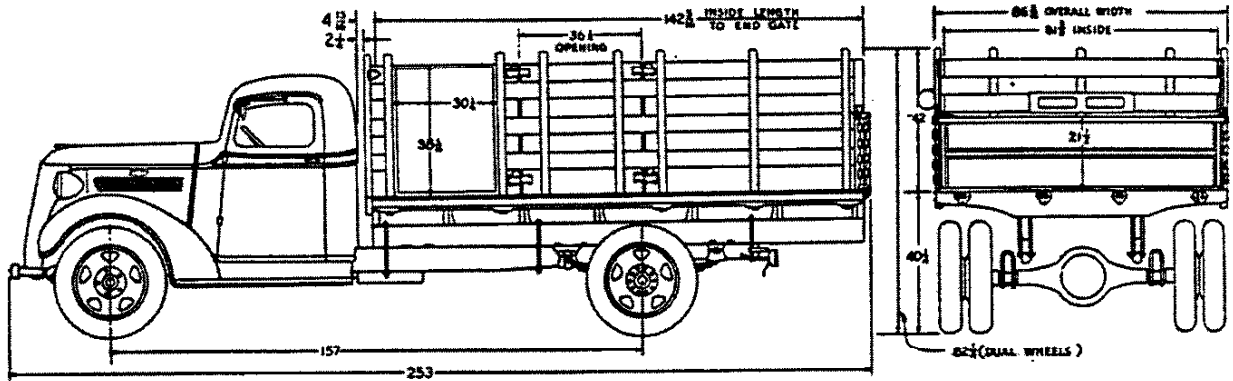

1-1/2 TON, 157" W.B. STOCK

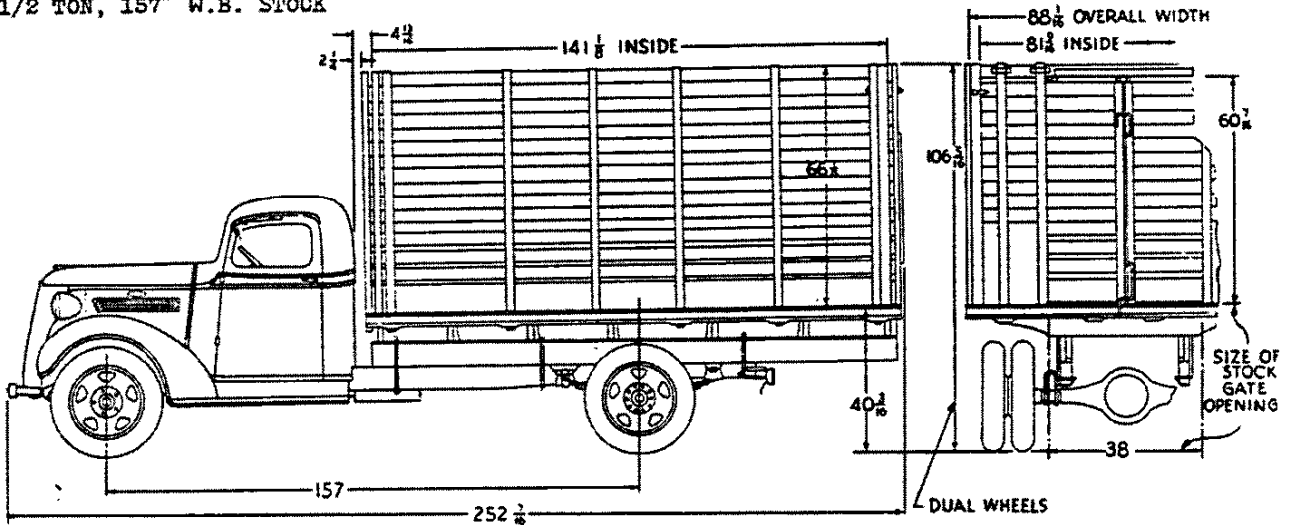

## SCHOOL BUS CHASSIS DIMENSIONS

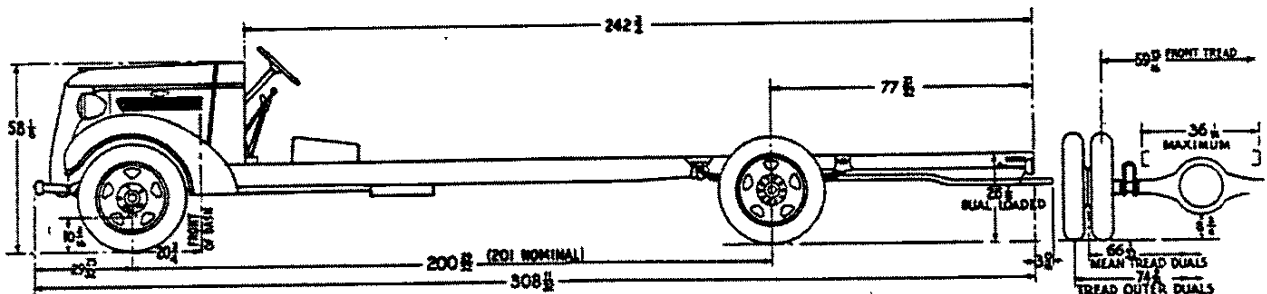

NOTE: Unless otherwise specified, all vertical dimensions are for design load conditions.

10-15-37, 1-21-38 - School Bus chassis added.

## TRUCK BODY DIMENSIONS



## TRUCK CHASSIS DIMENSIONS

### HALF TON TRUCK CHASSIS

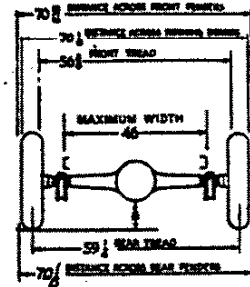
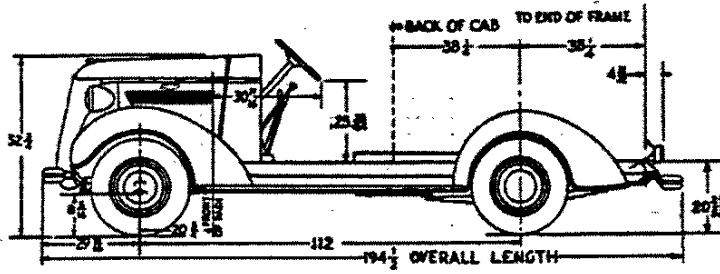

### 3/4 TON TRUCK CHASSIS ONE TON TRUCK CHASSIS

	A	B	C	D	E	F
3/4 TON	53	8-9/16	22-13/16	57-13/32	8-3/32	60-7/16
ONE TON	54-11/16	10-1/4	24-1/2	56-1/4	9-5/8	59-9/32

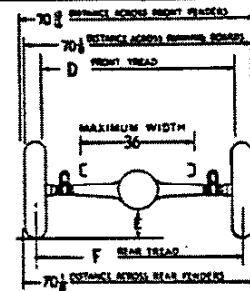
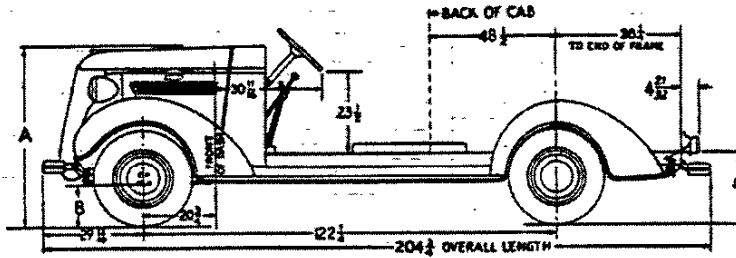

### 1-1/2 TON, 131-1/2" W.B. TRUCK CHASSIS

NOTE: Long running boards and rear fenders on single rear wheel chassis only.

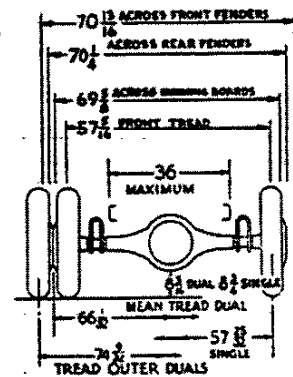
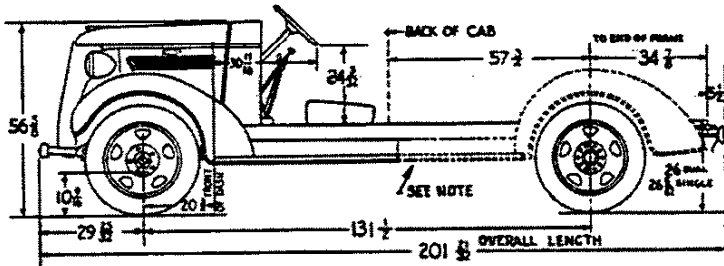

### 1-1/2 TON, 157" W.B. TRUCK CHASSIS

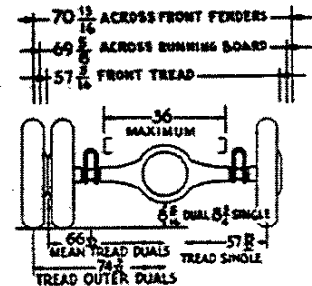
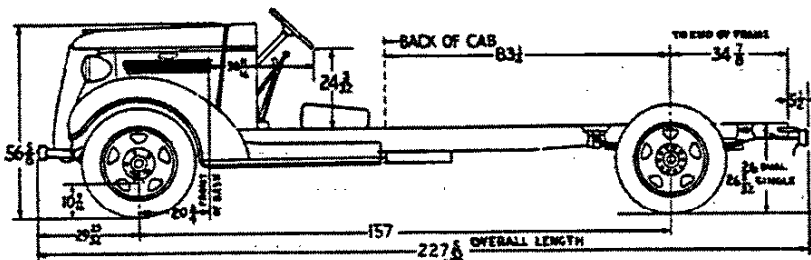

NOTE: Unless otherwise specified, all vertical dimensions are for design load conditions.

10-15-37, 1-21-38 - Chassis dimensions revised.

## TRUCK CHASSIS DIMENSIONS

## TRUCK COWL DIMENSIONS

### FLAT FACE COWL UNIT

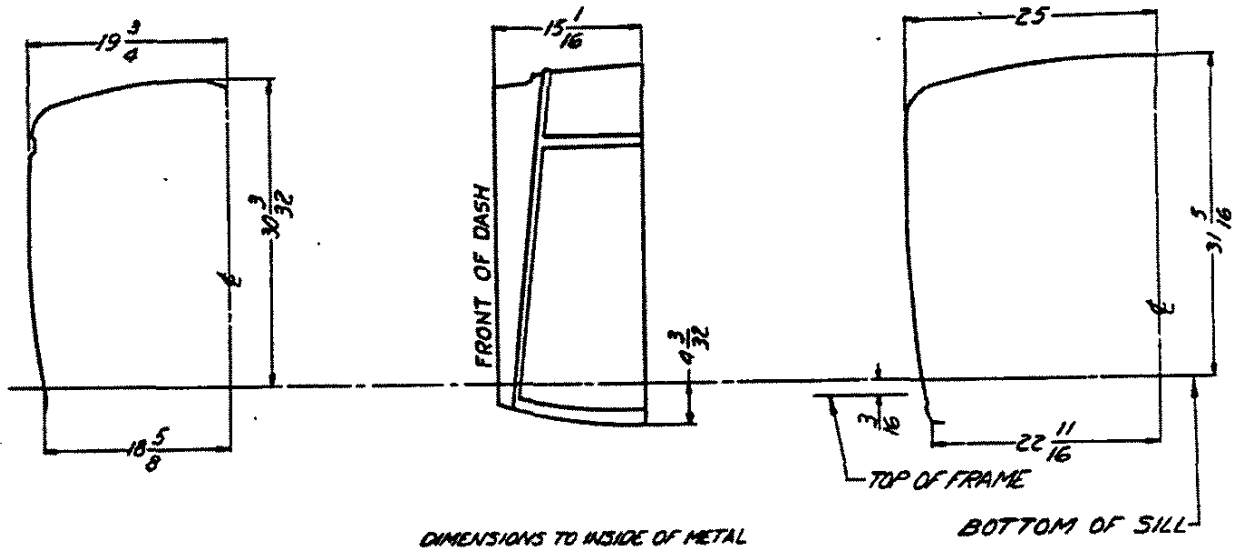

### COWL AND WINDSHIELD UNIT

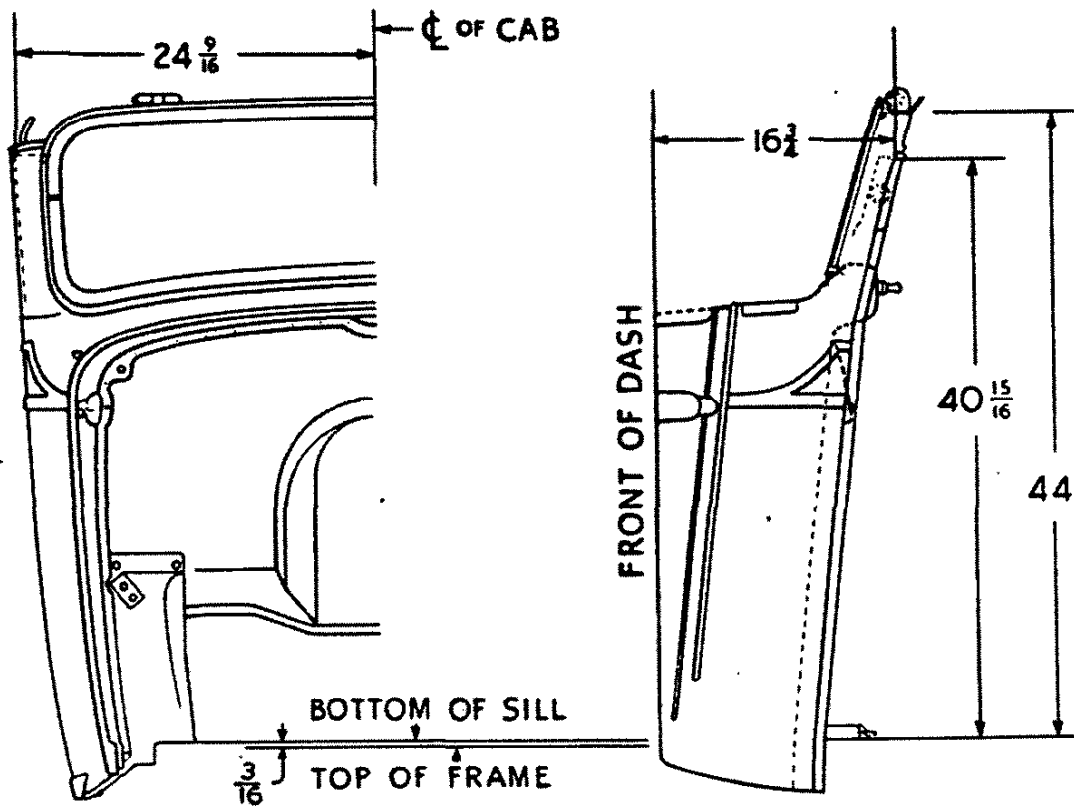

10-15-37

## FRAMES—PASSENGER CAR AND HALF-TON TRUCK

### DELUXE MASTER

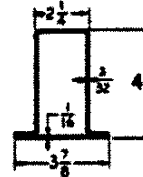
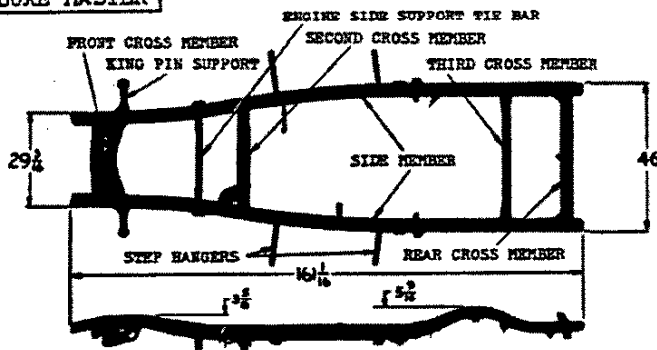

MAXIMUM SIDE MEMBER SECTION  
SECTION MODULUS 1.597 CU. IN.  
FRAME TYPE "BOX GIRDER"  
MATERIAL  
SPECIFICATION-GMC #1025  
HOT ROLLED PICKLED STEEL  
MINIMUM YIELD POINT 41,000  
POUNDS PER SQUARE INCH  
ELONGATION IN 2" = 35% to 40%  
WEIGHT 192# less K.P. support

### MASTER

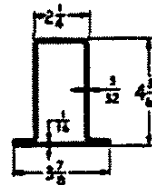
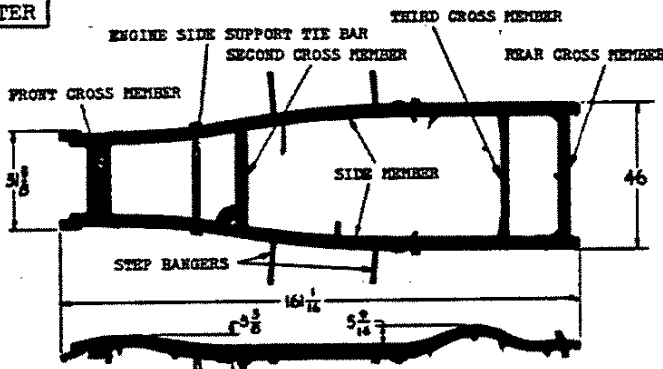

MAXIMUM SIDE MEMBER SECTION  
SECTION MODULUS 1.597 CU. IN.  
FRAME TYPE "BOX GIRDER"  
MATERIAL  
SPECIFICATION-GMC #1025  
HOT ROLLED PICKLED STEEL  
MINIMUM YIELD POINT 41,000  
POUNDS PER SQUARE INCH  
ELONGATION IN 2" = 35% to 40%  
WEIGHT 200#

### TAXICAB

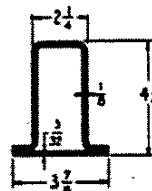
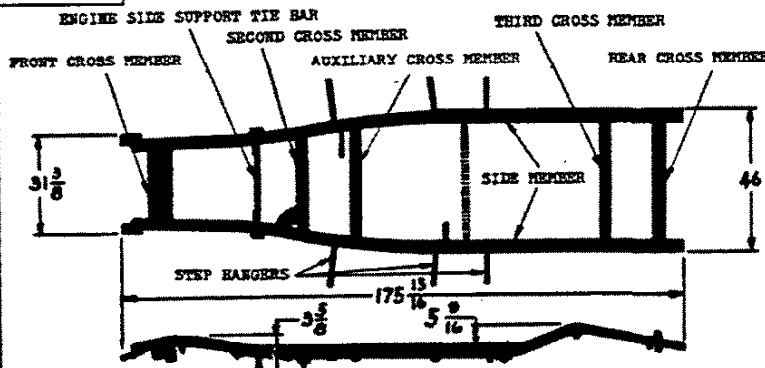

MAXIMUM SIDE MEMBER SECTION  
SECTION MODULUS 2.085 CU. IN.  
FRAME TYPE "BOX GIRDER"  
MATERIAL  
SPECIFICATION-GMC #1025  
HOT ROLLED PICKLED STEEL  
MINIMUM YIELD POINT 41,000  
POUNDS PER SQUARE INCH  
ELONGATION IN 2" = 35% to 40%  
WEIGHT 249#

### HALF TON TRUCK

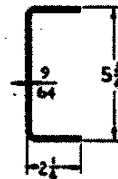
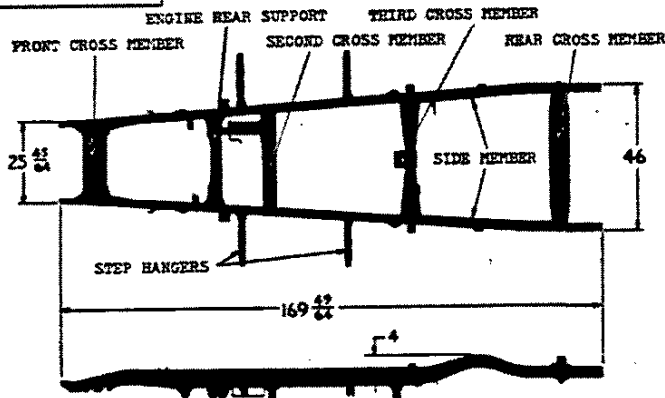

MAXIMUM SIDE MEMBER SECTION  
SECTION MODULUS 2.40 CU. IN.  
FRAME TYPE "CONVENTIONAL"  
MATERIAL  
SPECIFICATION-GMC #1025  
HOT ROLLED PICKLED STEEL  
MINIMUM YIELD POINT 41,000  
POUNDS PER SQUARE INCH  
ELONGATION IN 2" = 35% to 40%  
WEIGHT 240#

10-15-37, 1-21-38 - Taxicab frame added.

## FRAMES— $\frac{3}{4}$ , ONE, $1\frac{1}{2}$ TON TRUCKS AND SCHOOL BUS CHASSIS

3/4 AND ONE TON TRUCKS

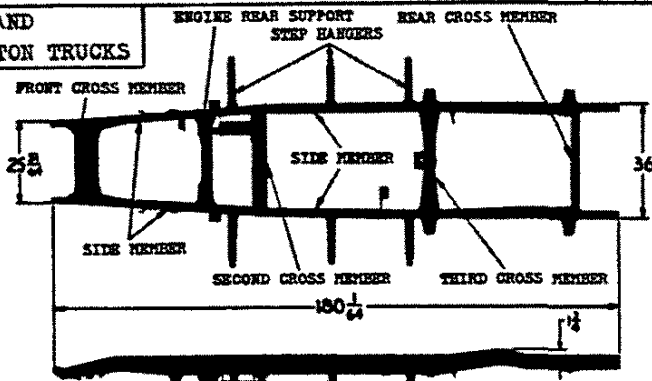

MAXIMUM SIDE MEMBER SECTION SECTION MODULUS 3.18 CU. IN. FRAME TYPE "CONVENTIONAL"

MATERIAL SPECIFICATION-GMC #1025 HOT ROLLED PICKLED STEEL MINIMUM YIELD POINT 41,000 POUNDS PER SQUARE INCH ELONGATION IN 2" = 35% to 40% WEIGHT 303#

1-1/2 TON TRUCK 131-1/2" W.B.

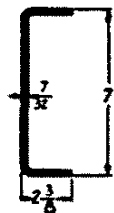
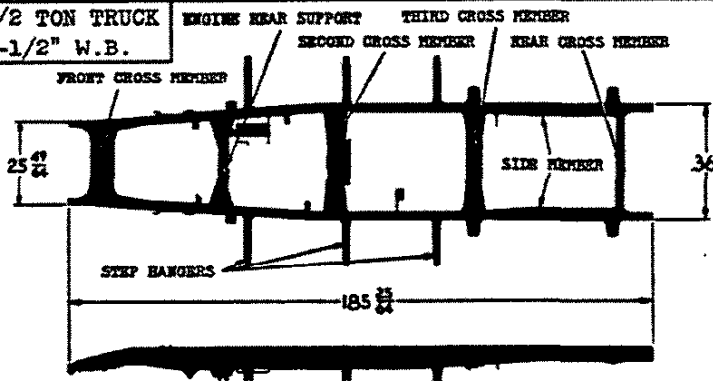

MAXIMUM SIDE MEMBER SECTION SECTION MODULUS 4.87 CU. IN. FRAME TYPE "CONVENTIONAL"

MATERIAL SPECIFICATION-GMC #1025 HOT ROLLED PICKLED STEEL MINIMUM YIELD POINT 41,000 POUNDS PER SQUARE INCH ELONGATION IN 2" = 35% to 40% WEIGHT 374#

1-1/2 TON TRUCK 157" W.B.

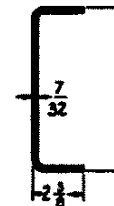
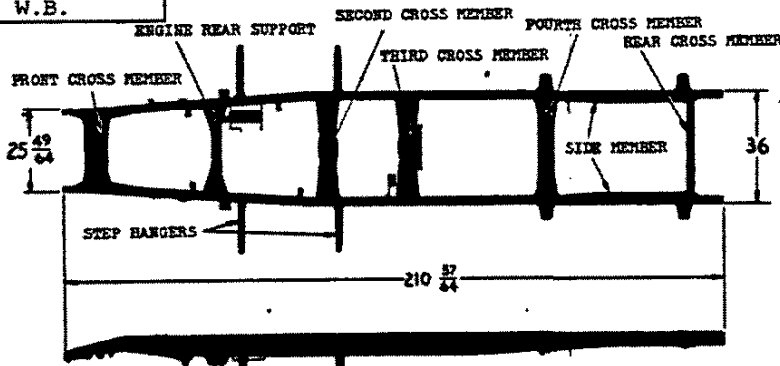

MAXIMUM SIDE MEMBER SECTION SECTION MODULUS 4.87 CU. IN. FRAME TYPE "CONVENTIONAL"

MATERIAL SPECIFICATION-GMC #1025 HOT ROLLED PICKLED STEEL MINIMUM YIELD POINT 41,000 POUNDS PER SQUARE INCH ELONGATION IN 2" = 35% to 40% WEIGHT 430#

SCHOOL BUS CHASSIS

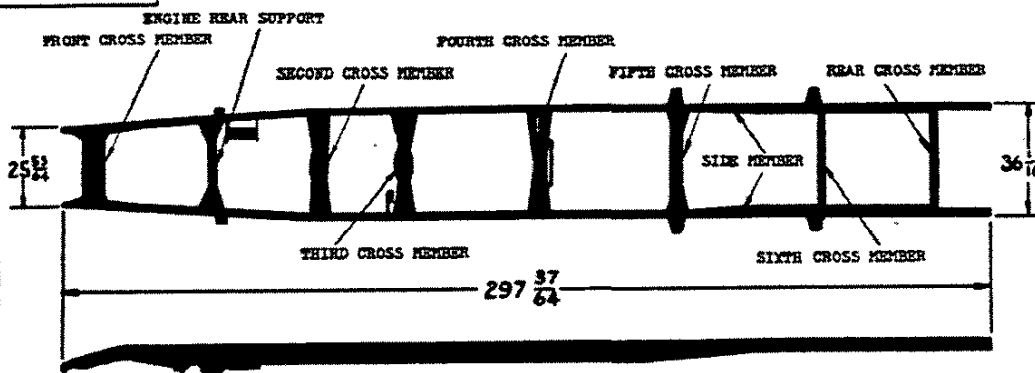

MAXIMUM SIDE MEMBER SECTION SECTION MODULUS 5.578 CU. IN. FRAME TYPE "CONVENTIONAL"

MATERIAL SPECIFICATION-GMC #1025 HOT ROLLED PICKLED STEEL MINIMUM YIELD POINT 41,000 POUNDS PER SQUARE INCH ELONGATION IN 2" = 35% to 40% WEIGHT 634#

10-15-37, 1-21-38 - School Bus chassis frame added.

## KNEE ACTION FRONT SUSPENSION—MASTER DELUXE

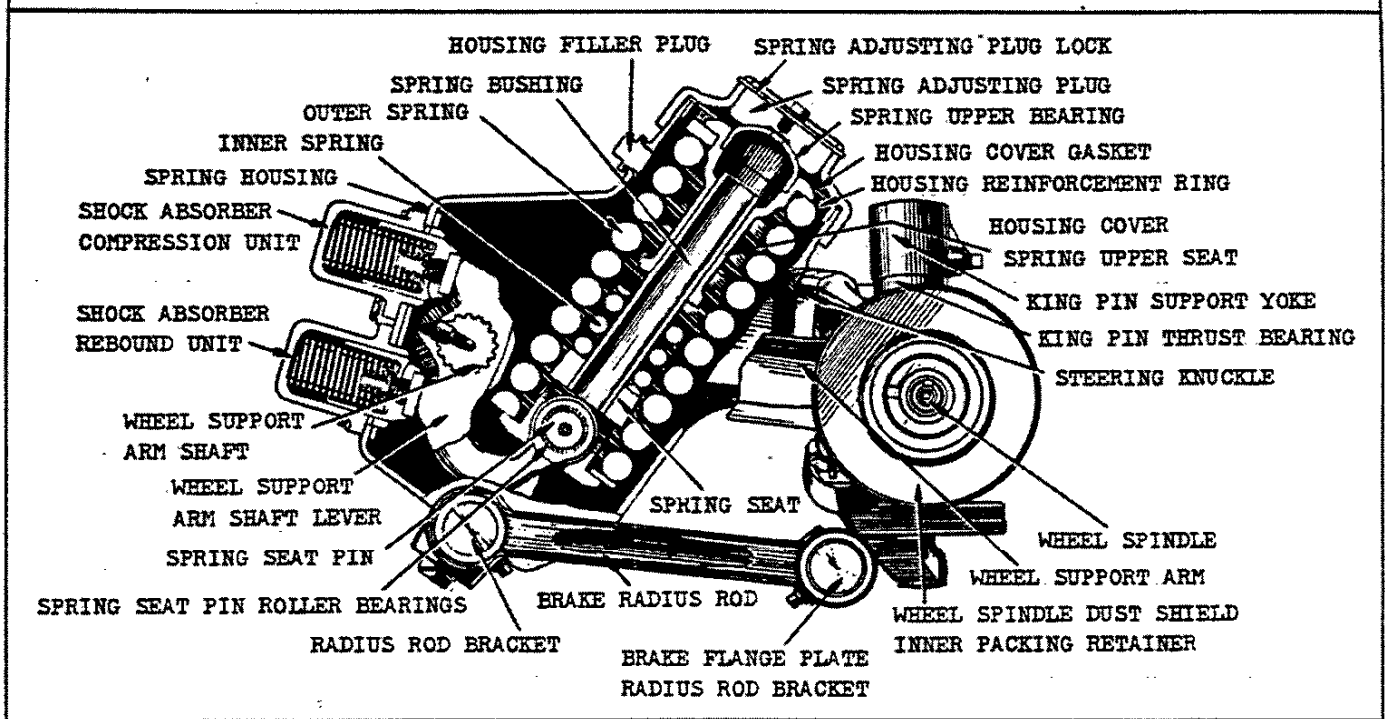

SPRINGS	OUTER	INNER
Type	Coil	
Material	Silico - Manganese Steel	
Gauge (Dia.)	11/16"	7/16"
Free length	9-11/16"	1-27/32"
Working length	8" at 2620# load.	1-21/32" at 1000# load.
Number of coils	11	4
Coils O.D.	3-19/32"	1-31/32"
Deflection rate	1520#/inch	5300#/inch

SPRING FREQUENCY	AT CURB LOAD	AT FULL LOAD
Cycles per minute	79	76

WHEEL TRAVEL		
For steering	37° from neutral to stop	
Vertical	2-7/8" normal setting to bumper	
Ratio	3.52 to 1 (wheel to spring)	
Effect of wheel travel on spring pressure.	Wheel travel	Spring travel
	In vertical path 2-1/8" from normal setting position at rate of 123#/inch.	Outer spring travels 5/8"
	Wheel continues 23/32" more at rate of 550#/inch	Both springs travel 1/4" at 6820#/inch

BEARINGS	WHEEL SUPPORT ARM SHAFT LEVER	SPRING SEAT PIN	WHEEL BEARINGS	KING PIN BEARINGS	KING PIN THRUST BEARING
	OUTER BEARING				
Type	Special rollers			See next page	
Number of rollers	49	42	32		
Roller diameter	3/32"				
Roller length	31/32"	1-3/16"	31/32"		
Roller material	Cold Drawn Steel - Hardened				

10-15-37, 1-21-38 - Part names transposed.

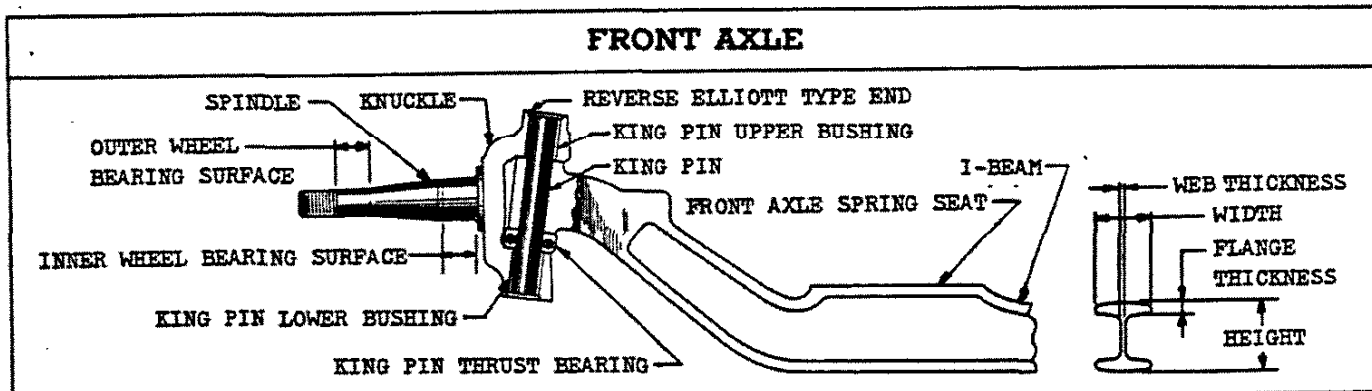

ITEM	PASSENGER CARS			TRUCKS		
	MASTER DELUXE	MASTER TAXI	HALF, 3/4, ONE TON	1-1/2 TON	SCHOOL BUS	
Type	Elliott			Reversed Elliott-Modified I-beam Section		
I-beam	Height	2"	2-1/8"	2-11/32"	2-3/8"	
	Width	1-5/8"	1-3/4"	2-1/16"	2"	
	Flange thick.	1/4"	7/32"	5/16"	7/16"	
	Web thick.	7/32"	1/4"	3/8"	1/4"	
King pin	Diameter	.8660"-.8665"	.7355"-.7359"	.9210"-.9214"	1.1085"-1.1095"	
	Material	Cold drawn steel, case hardened				
King pin bushings	Type	Cast Bronze	Hard rolled Bronze		Brass	
	Inside dia.	.867"-.868"	.7345"-.7355"	.922"-.923"	1.1095"-1.1105"	
	Length	1-5/16"	1-17/64"		1-11/32"	
King pin Thrust Brg.	Type	Special Ball			Roller	
Location	Above Knuckle			Below Axle		
Wheel Bearings	Inner	N.D. #909002		N.D. #909026		Hy. #173241
	Outer	N.D. #909001		N.D. #909025		Hy. #173238
Spindle Diameter	Inner Brg.	1.1890"-1.1895"		1.4051"-1.4056"		1.5618"-1.5623"
	Outer Brg.	.7490"-.7495"		.8427"-.8432"		.9368"-.9373"
Rated Capacity	2000#		2200#	3500#	4500#	

FRONT WHEEL ALIGNMENT (SERVICE DIMENSIONS)						
ITEM	PASSENGER CARS			TRUCKS		
	MASTER DELUXE	MASTER TAXICAB	HALF, 3/4, ONE TON	1-1/2 TON	SCHOOL BUS	
King pin angle	7°-45'@			7°-10' +1°		
Camber	1/4°@			1° + 1/2°		
Caster	0°@	2°-15' + 1/2°	2° + 1/2°	1°-45' + 1/2°	2°-45' + 1/2°	
Toe-in	1/16" to 3/32"@			5/64" to 1/8"		
Wheel setting	4-7/8" + 1/8"@@			In 23° - Out 20°		

MASTER DELUXE DATA

@ - Caster, king pin angle and camber are measured from the frame with approved Chevrolet gauge with curb weight on spindles.

@@ - Wheel setting is measured from the bottom of the king pin support to the bottom of the brake flange plate under curb load.

10-15-37, 1-21-38 - Taxicab & School Bus added. Bushing dia. changed from outside to inside dimension.

## SUSPENSION

## FRONT SPRINGS

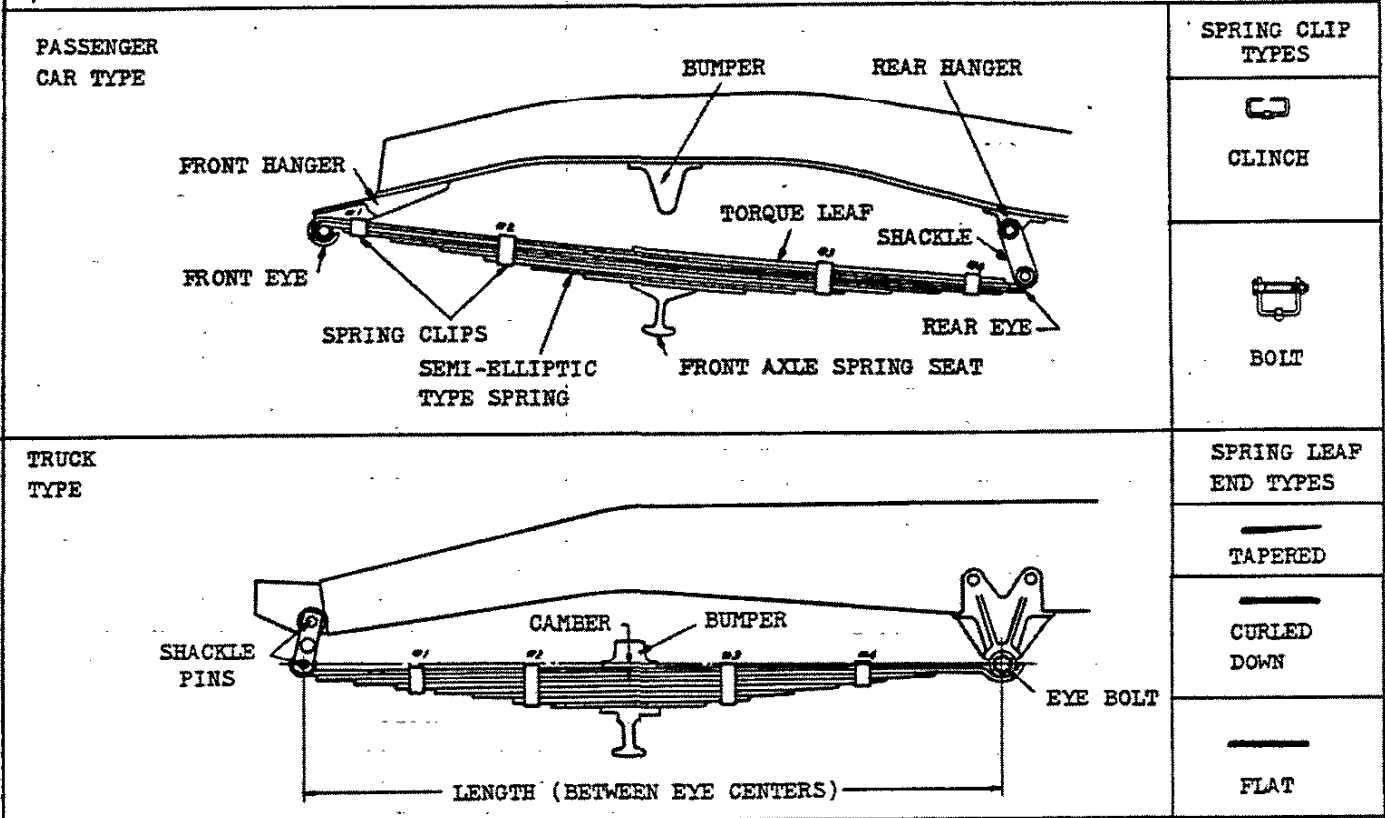

ITEM	PASSENGER CARS			TRUCKS			SCHOOL BUS
	MASTER PASSENGER	MASTER SED. DELIVERY	TAXICAB	HALF TON	3/4 TON & ONE TON	1-1/2 TON	
Type	Semi-Elliptic						
Material-Steel	Chromium		Sil-Man	Chromium		Chromium Vanadium	
Number of Leaves	9	8	9	8		9	11
Thickness of leaves	#1	.203"	.214"	.284"		.340"	.300"
	#2		.237"				
	#3	.220"	.194"	.259"		.284"	
	#4						
	#5						
	#6,7,8	.203"	None	None		.259"	.259"
#9							
#10,11	None						
Total thickness	1.878"	1.814"	2.122"		2.487"		2.990"
Length x Width	36" x 1-3/4"						
Torque leaf	One	None					
Camber (Av.)	7/16"	1/2"	1/2" Reverse	Flat	3/8"	23/32"	9/16"
Load at camber height (Av.)	610#		770#	750#	785#	950#	1550#
Deflection (Av.)	235#/"	310#/"	258#/"	475#/"		645#/"	700#/"
Leaf end type	Tapered	Curled down				Flat	
Spring clip types	#1	Clinch					Bolt
	#2	Clinch	Bolt	None		Bolt	
	#3	Clinch	Bolt	Clinch		Bolt	
	#4	Bolt	Clinch				Bolt

10-15-37, 1-21-38 - Taxicab and School Bus added.

## SUSPENSION

## FRONT SPRING MOUNTING

### SHACKLE TYPES

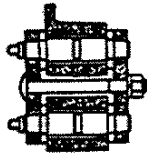

PLAIN H

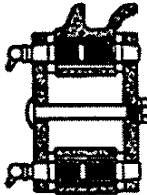

THREADED H

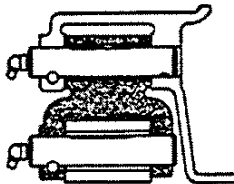

CLEVIS

### SPRING EYE TYPES



BERLIN EYE - WRAPPED



OVERHUNG - SINGLE WRAPPED



UNDERSLUNG (REVERSED)  
SINGLE WRAPPED



UNDERSLUNG (REVERSED)  
DOUBLE WRAPPED

### EYE BOLT AND BUSHING TYPES

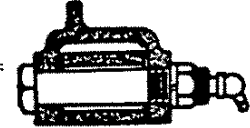

PLAIN

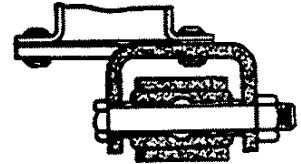

RUBBER BUSHED

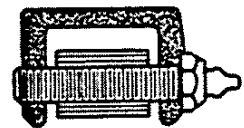

THREADED

ITEM	PASSENGER CARS		TRUCKS			
	MAS. PASSENGER & TAXICAB	MASTER SEDAN DELIVERY	HALF TON	3/4 TON & ONE TON	1-1/2 TON	SCHOOL BUS
Front eye type	Underslung, double wrapped	Underslung, single wrapped	Overhung Single wrapped			
Rear eye type	Overhung, single wrapped		Berlin eye, wrapped			
Shackle	Location At rear		At front			
	Type	Threaded H				
Shackle pins	Material Carbon steel, file hard case					
	Diameter	.619" P.D., 11 threads per inch. Threads-cadmium plated				
Eye bolt	Material Carbon steel, hardened		Carbon steel, file hard case			
	Diameter	.616" P.D., 11 threads per inch		.683"		
	Type	Threaded for front bushing		Screwed into hanger		
Front bushing	Material Carbon steel, file hard case					
	Size	.630" P.D., 11 threads x 1-3/4"				
	Type	Threaded for eye bolt		Threaded for shackle pin		
Rear bushing	Material Carbon steel, file hard case		Bronze			
	Size	.630" P.D., 11 threads x 1-3/4"		.860" I.D. x 1-11/16"		
	Type	Threaded for shackle pin		Plain		
Spring-axle assembly	2 U-bolts per spring					
Spring	Material H.R. steel, hardened					
U-bolt	Diameter 1/2"					
Bumper material	Spring bumper rubber					
Spring mounting	Parallel		8° - 4' (included angle)		7° - 49' (included angle)	
Spring centers	28-1/8"		26-11/16"		26-29/32"	
					26-13/16"	
					26-27/32"	

10-15-37, 1-21-38 - Taxicab and School Bus added.

## SUSPENSION



## REAR SPRINGS

PASSENGER CAR AND  
HALF TON TRUCK  
TYPE REAR SPRING

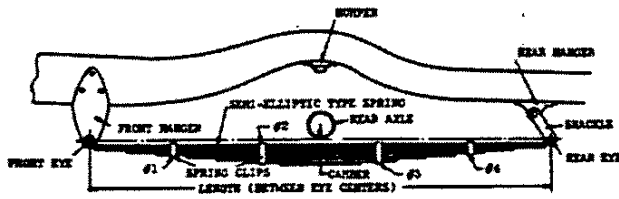

SCHOOL BUS SPRING  
(PROGRESSIVE TYPE)

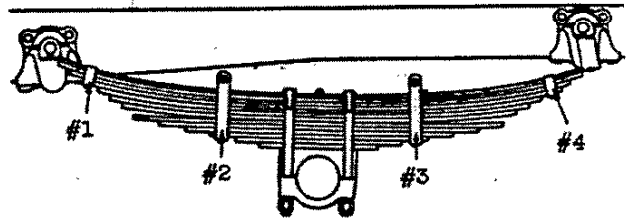

3/4 TON, ONE TON AND 1-1/2 TON TRUCK TYPE REAR SPRING

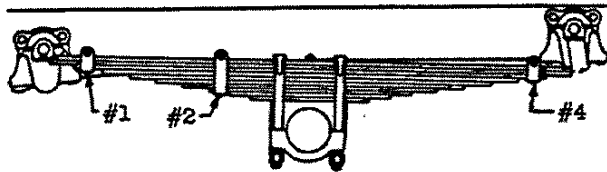

1-1/2 TON TRUCK REAR SPRING WITH AUXILIARY SPRING

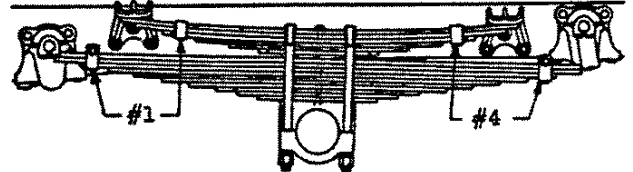

ITEM	PASSENGER CARS					TRUCKS						
	Spt. Sed., To. Sed., Sedan, Coach, C. Pickup	Bus. Cpe., Deluxe Spt. Cpe., Master Cabriol.	Master Sedan Deliv.	Taxi- Cab		Half Ton	3/4 Ton	One Ton	1-1/2 Ton Panel Truck	All other 1-1/2 Ton Trucks		School Bus
Type	Semi-elliptic											
Material-Stl.	Chromium			Sil-Man	Chrome	Silicon Manganese						
Number leaves	8	7	8	9	8	9	8	10	6	13		
Thick- ness of leaves	#1	.238"	.259"	.262"	.300"	.312"	.312"	.284"	.312"	.340"	.340"	.300"
	#2			.237"								
	#3 & 4											
	#5	.220"	.238"	.214"	None	None	None	None	None	None	None	.375"
	#6											
	#7											
	#8											
	#9	None	None	None	None	None	None	None	None	None	None	None
	#10											
	#11,12,13											
	Total thick.	1.850"	1.576"	1.946"	2.066"	2.400"	2.500"	2.812"	2.384"	3.290"	2.040"	4.200"
Length	49"				54-1/8"	45"				33-1/2"	45"	
Width	1-3/4"				2"			2-1/2"				
Camber (Av.)	3/8" Reverse			3/8"	7/16"	15/32"	5/32"	1"	7/16"	None	.5" Rev.	
Load at Camber height (Av.)	950#	745#	1050#	1150#	1400#	1650#	1500#	2950#	Engage at 1760#	3850#		
Deflect. (Av.)	129#/"	105#/"	150#/"	140#/"	200#/"	450#/"	505#/"	490#/"	840#/"	1610#/"	**	
Leaf end type	Curled down					Flat						
Spring	#1	Clinch			Bolt			Clinch				
Clip	#2	Clinch (Master only)			Bolt	Bolt			None			Bolt
Type	#3	Clinch (Master only)			Bolt	Clinch			None			Bolt
	#4	Clinch			Bolt			Clinch				
Spring covers	Metal - DMAS				None							

\* - Available at extra cost. \*\* - 550#/" up to 2800#; 1040#/" full spring contact.

10-15-37, 1-21-38 - Taxicab and School Bus added.

## SUSPENSION

# CHEVROLET 1938 SPECIFICATIONS

REAR SPRING MOUNTING					
ITEM	PASSENGER CARS		TRUCKS		
			HALF TON	3/4 & ONE TON	1-1/2 TON & SCHOOL BUS
Front eye type	Overhung-single wrapped				
Rear eye type	Underslung-Single wrapped		Overhung, single wrapped		
Shackle	Location	At rear			
	Type	Threaded H		Clevis, bronze bushed	
Shackle pins	Material	Carbon steel, file hard case			
	Diameter	.619" P.D., 11 threads per inch Threads-Cadmium plated		.875"	
Eye bolt or pin	Material	Carbon Steel, hardened			
	Diameter	.502"	.683"	.875"	
Front bushing	Type	Plain		Screws into hanger	
	Material	Rubber and steel		Bronze	
	Size	.505" min.I.D. x 2.405"	.687" I.D. x 1-11/16"	.878" I.D. x 1.990"	.878" I.D. x 2.490"
	Housing	Stl.1-5/32" O.D. x 2"			
Rear bushing	Type	Rubber bushed		Metal-plain	
	Material	Carbon Steel, file hard case		Carbon steel	
	Size	.630" P.D., 11 threads x 1-3/4"		.878" I.D. x 1.990"	.878" I.D. x 2.490"
Spring-axle attachment	* 2 U-bolts to rubber bushed seat on housing		2 U-bolts to metal seat and cap around housing		
Spring U-bolt	Material	Carbon steel, hardened			Carbon steel
	Diameter	1/2"			5/8"
Spring bumper	Rubber on frame		Rubber on spring		Rubber on frame
Spring mounting	Parallel		8°-4' inc. angle		Parallel
Spring centers	44-11/16"		42-25/64"		42-1/2"      42"

\* - 2 U-bolts to cap and offset metal seat around housing on the Taxicab.

SHOCK ABSORBERS AND RIDE STABILIZER															
ITEM	PASSENGER CARS						TRUCKS								
	MASTER DELUXE		MASTER		TAXICAB		HALF TON		3/4 TON		ONE TON		1-1/2 TON & SCHOOL BUS		
	Front	Rear	Front	Rear	Front	Rear	Front	Rear	Front	Rear	Front	Rear	Front	Rear	
Shock Absorbers	Make	Delco-Hydraulic													
	Type	Double acting **		Single acting											
	Valve Code No.	1BX(bumper)	1B(rebound)	2EE	5G		3EE	4CG	3CG	4CG	3CG	4CG	None		
	Piston dia.	1-1/2"		1-1/4"				1-1/2"							
Ride Stabilizer	Type	None						Torsion Bar		None					
	Mounting							Bolted to rear shock absorber arms							
	Material							H.R. Steel, hardened							

\*\* - See Knee-Action page 27.

10-15-37, 1-21-38 - Taxicab and School Bus added.

## SUSPENSION

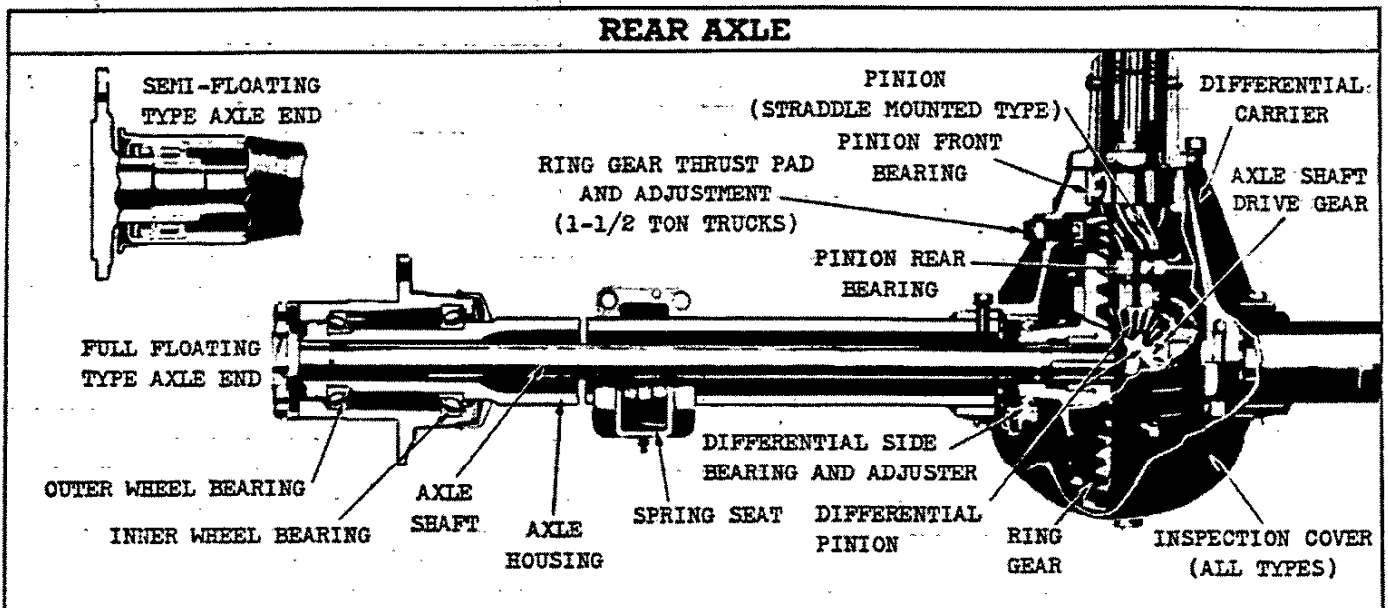

ITEM	PASSENGER CARS				TRUCKS							
	MASTER DELUXE	MASTER	TAXI-CAB	HALF TON				3/4 & ONE TON		**1-1/2 TON	SCHOOL BUS	
				3 SPD. REG.	TRANS. OPT.	4 SPD. REG.	TRANS. OPT.	3 SPD. TRANS.	4 SPD. TRANS.			4 SPEED TRANS.
Type	Semi-floating								Full-floating			
Gross rating	3000#			3300#				3900#		10,300#		
Housing type	Pressed steel banjo. Formed in two longitudinal pieces which are welded together along the seams.						Banjo. From 1 piece welded steel tube.		Banjo. From 1 piece seamless steel tube.			
Final gears	Type	Spiral hypoid			Spiral bevel							
	Ratio	4.222	3.727	4.111	3.818	4.111	3.818	4.111	5.428	6.166		
	Teeth	38-9	41-11	37-9	42-11	37-9	42-11	37-9	38-7	37-6		
Gear back-lash	.005"-.007"			.006"-.010"								
P I N I O N	Mounting	Overhung								Straddle		
	Adjustment	Shims and tapered collar								None		
	Front brg.	N.D. 905206								N.D. 905309		
	Rear brg.	Hyatt 125630								N.D. 901305		
Thrust	Against front pinion bearing											
Diff. type	Two pinion								Four pinion			
Diff. side brg.	Hyatt 127861			N.D. 902100				N.D. 954186				
Wheel bearing	Hyatt 111103			Hyatt 111104				Inner-Hy. 144527 Outer-Hy. 144525				
Axle Type	Drive flange at wheel end forged integral with shaft											
Shaft Min.Dia.	63/64"			1-1/16"				1-7/16"				
Drive torque	Through torque tube											
Total @ gear reductions	1st.	12.407	10.966	12.083	11.225	29.706	27.589	12.083	29.706	39.222	44.556	
	2nd.	7.089	6.266	6.905	6.414	14.298	13.279	6.905	14.298	18.879	21.445	
	3rd.	4.222	3.727	4.111	3.818	7.034	6.533	4.111	7.034	9.287	10.540	
	4th.					4.111	3.818	None	4.111	5.428	6.166	
	Reverse	12.407	10.966	12.083	11.225	29.385	27.291	12.083	29.385	38.799	44.085	
Total@@ axle shaft torque (ft.lb.)	1st.	1792	1585	1745	1621	2061*	2061*	1745	2061*	5665	6435	
	2nd.	1023	905	998	928	2061*	1915	998	2061*	2725	3098	
	3rd.	610	538	505	552	1015	944	595	1015	1341	1522	
	4th.	None				595	552	None	595	784	890	
	Reverse	1792	1585	1745	1621	2061*	2061*	1745	2061*	5606	6370	

@ - R.A. ratio x trans.ratio. @@ - Total gear reduction x max.engine torque x 85%. \* - Maximum.  
 \*\* - Rear Axle with 6.166 gear ratio is optional; data listed under School Bus.  
 10-15-37, 1-21-38 - Taxicab and School Bus added.

## REAR DRIVE SYSTEM

## UNIVERSAL JOINTS AND PROPELLER SHAFTS

PASSENGER CAR & HALF TON TRUCK  
YOKE & RING TYPE UNIVERSAL JOINT

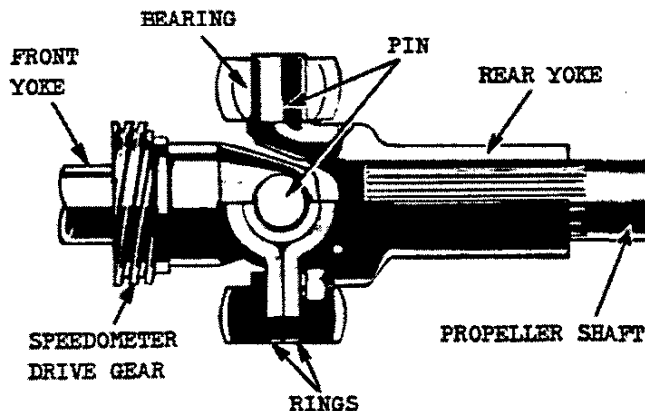

3/4 TON, ONE TON, 1-1/2 TON & SCHOOL BUS  
YOKE & SPIDER TYPE UNIVERSAL JOINT

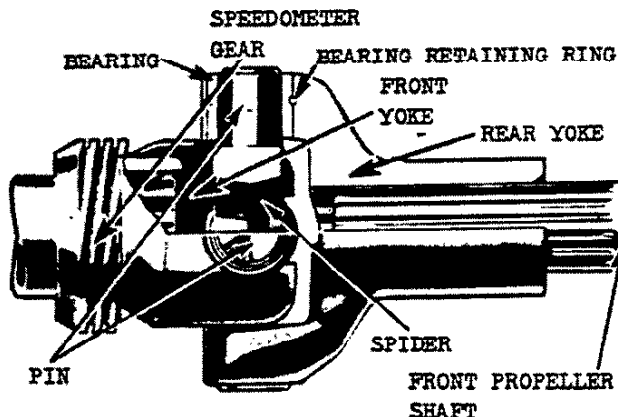

FRONT JOINT SHOWN

ITEM	PASSENGER CARS				TRUCKS					
	MASTER DELUXE	MASTER	TAXI	HALF TON	3/4 TON	ONE TON	1-1/2 TON		SCHOOL BUS	
UNIVERSAL JOINTS	Type	Yoke and ring			Yoke and spider					
	Number	One	Two	One	Two		Three			
	Location of joints	Front	Transmission							
		Center	None							3rd cross member
	Rear	None	Aux. cross member	None	2nd cross member		3rd cross member	4th cross member		
		Yoke material		Drop forged steel, hardened						
	Pin diameter		.6865"-.6875"			.716"-.717"				
	BEARING	Mat'l.	Carbon steel, file hard case							
		Number	Four							
		Size	.6895"-.6915" I.D. x 5/8" long				.718"-.719" I.D. x 7/8"-.725" long			
Centers		2-3/4"			2-15/16"					
Ball centers	Front	None	14-3/4"	None	10-1/4"	24.425"	49.861"	49-29/32"		
	Center	None							43-55/64"	
SPEEDOMETER GEAR	Material	Carb.stl.file hard surface	Moly.steel case hard.	Carbon steel, file hard surface						
	Pitch	30	22	20	18.629	22	22-Drive, 22.403-Driven			
	Teeth	Drive	6	5	4		5	4	4	
		Driven	19	14	12		13	13		
Driven gear mounting	Peened on shaft		Pinned to shaft	Peened on shaft						
PROPELLER SHAFT	Type	Tubular		Solid front, tubular rear	Tubular	Solid front, tubular rear	All-Solid			
	Number	One		Two	One	Two		Three		
SHAFT	O.D.	Front	None	.960"-.970"	None	1.274"-1.284"		1.283"-1.284"		
		Center	None							1.283"-1.284"
		Rear	1.690"-1.700" x .094" ± .002" wall thickness					1.283"-1.284"		
Type of ends	10 Splines (See splines)									
LENGTH	Length	Front	None	12-41-64"	None	8-11/16"	22-7/8"	48-17/64"		
		Center	None							42-5/16"
		Rear	59-1/4"	58-29/64"		53-11/64"				

\* - Specifications listed for regular equipment.

10-15-37, 1-21-38 - Taxicab and School Bus added.

## REAR DRIVE SYSTEM

# CHEVROLET 1938 SPECIFICATIONS

35

BRAKES						
ITEM	PASSENGER CARS		TRUCKS			
			HALF TON	3/4 TON	ONE TON	SCHOOL BUS
Service brake type	Hydraulic, 4 wheel, internal expanding, double articulated shoe					
Hand brake type	Cut-in system on two rear service brakes actuated mechanically and entirely separate from hydraulic system. Pull rods and cables operate two shoes in each brake through toggle linkage.					
Brake drum	Type	Composite (Cast iron rim with cooling ribs, pressed steel web)				Pressed steel
	Dia-meter	Front	11"		14"	14"
		Rear	11"	14"	16"	16"
Brake lining	Material	Full-moulded				Semi-moulded
	Width	Front	1-3/4"		2"	2"
		Rear	1-3/4"	2"	2"	3"
	Thick-ness	Front	.187"-.194"		.272"-.275"	.243"-.250"
		Rear	.187"-.194"	.265"-.272"	.272"-.275"	.243"-.250"
Clear-ance	Front	Adjust to slight drag. Back off 4 notches				
	Rear	Adjust to slight drag Back off 4 notches	Adjust to slight drag Back off 2/3 screw turn			
Lining area (total effective)	Service brake	158-1/4 sq.in.		194-1/2 sq.in.	330-1/4 sq.in.	
	Hand brake	79-1/8 sq.in.		115-3/8 sq.in.	214-3/4 sq.in.	
Braking pressure	Front	52-1/2%		45-1/4%	37-1/4%	41%
	Rear	47-1/2%		54-3/4%	62-3/4%	59%
Braking ratio	Pedal	4.78:1	5.15:1	5.25:1		
	Hydraulic	11.89:1		7.61:1	8.84:1	10.82:1
	Av. overall (pedal to brake)	56.8:1	61.3:1	40.0:1	46.4:1	57.1:1
Foot pedal	Travel	6-11/32"	6-1/2"	7-3/4"		
	Mounting	With main cylinder to frame	With main cylinder to trans. case & clutch housing	On clutch housing		
	Pads, rubber	Master Deluxe, Master Cabriolet & Taxicab only				
Hand brake lever mounting	To frame	To transmission				

BRAKES HYDRAULIC DATA						
ITEM	PASSENGER CARS		TRUCKS			
			HALF TON	3/4 TON	ONE TON	SCHOOL BUS
Wheel cylinder	Diameter	Front	1-1/4"			
		Rear	1-3/16"	1-3/8"	1-5/8"	1-1/2"
	Piston travel for full pedal stroke	.110"	.130"	.125"		
Main cylinder	Diameter	1"				
	Piston travel for full pedal stroke	1-5/16"	1.27"	.993"	1.225"	
Brake system fluid capacity	3/4 pint approximately					
Brake fluid recommended	Delco #5 for temperatures above zero to 10° below zero Delco #4 for temperatures above zero to 20° below zero Delco #3 for temperatures from 30° above zero to 30° below zero Delco #1 for temperatures consistently below 10° below zero					

10-15-37, 1-21-38 - Data revised. Taxicab & School Bus added.

## BRAKES

## ENGINE GENERAL DATA

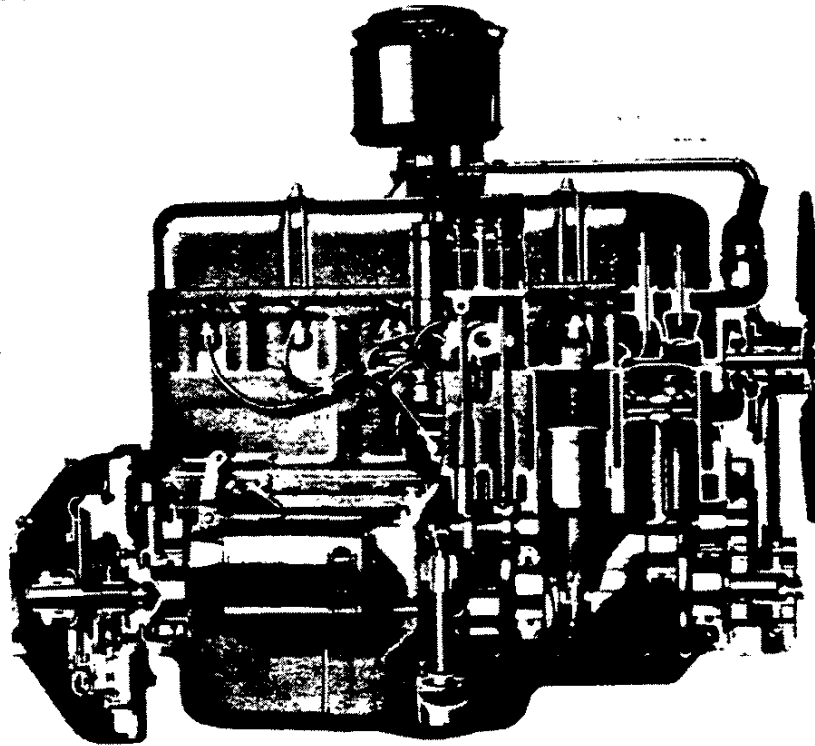

ITEM	PASSENGER CARS			TRUCKS						
	MASTER DELUXE	MASTER	TAXI-CAB	HALF TON	3/4 TON	ONE TON	1-1/2 TON + S.W.	SCHOOL BUS +D.W.	SCHOOL BUS	
Type	Valve-in-head									
Cylinders	Six in line-Cast en bloc									
Bore x Stroke	3-1/2" x 3-3/4"									
Compression ratio	6.25:1									
Horse-power	Taxable H.P. 29.4									
	Max. B.H.P. 85 at 3200 RPM			78 at 3200 RPM						
	Max. B.H.P./cu.in. disp.* .393			.360						
Torque	Maximum * 170 ft.lbs.									
	RPM at Max. torque * 900-2000			850-1550						
Engine speeds	Maximum 4000 RPM									
	Max. with governor No governor			1400-3000 RPM						
Max. B.M.E.P.*	116 lbs./sq.in. at 1550 RPM									
Piston displacement	Total 216.5 cu.in.									
	P.D./ton mile (cu.ft.)	113.27@	102.2@	- - -	87.4	71.6	58.1	56.0	47	- - -
	P.D./car mile (cu.ft.)	197.4@	174.3@	- - -	192.2	186.3	168.6	212.6	218.8	- - -
	Gross wgt. for computation	3485#@	3410#@	- - -	4400#	5200#	5800#	7600#	9300#	- - -
	Car wgt./cu.in. disp. X	13.46#	13.12#	- - -	- - -	- - -	- - -	- - -	- - -	- - -
Engine RPM/mile per hour	52.5	46.33	51.11	49.60	44.82	56.55	58.17	64.23		
Engine revs./mile in high	3150	2780	3067	2976	2689	3393	3490	3854		
Piston travel in high, ft./mile	1969	1737	1917	1860	1681	2121Y	2181Y	2409		
Weight (dry)	Engine complete 546.5#			554#		562.25#				
	Power plant complete** 590#			600.5#		608.75#		654#		

\* - Engine tests are made on the dynamometer less accessories at 60° F according to SAE standard tests.  
 X - Sedan shipping weight. Y - With 5.428 rear axle gear ratio. @ - Passenger car weights are based on Sedan curb weights plus 450# for passengers. +S.W. - Regular single wheels. D.W. - Regular dual wheels.  
 \*\* - Power plant weight includes engine, clutch and complete transmission.

10-15-37, 1-21-38 - Taxicab and School Bus added.

### ENGINE

PASSENGER CAR POWER AND TORQUE

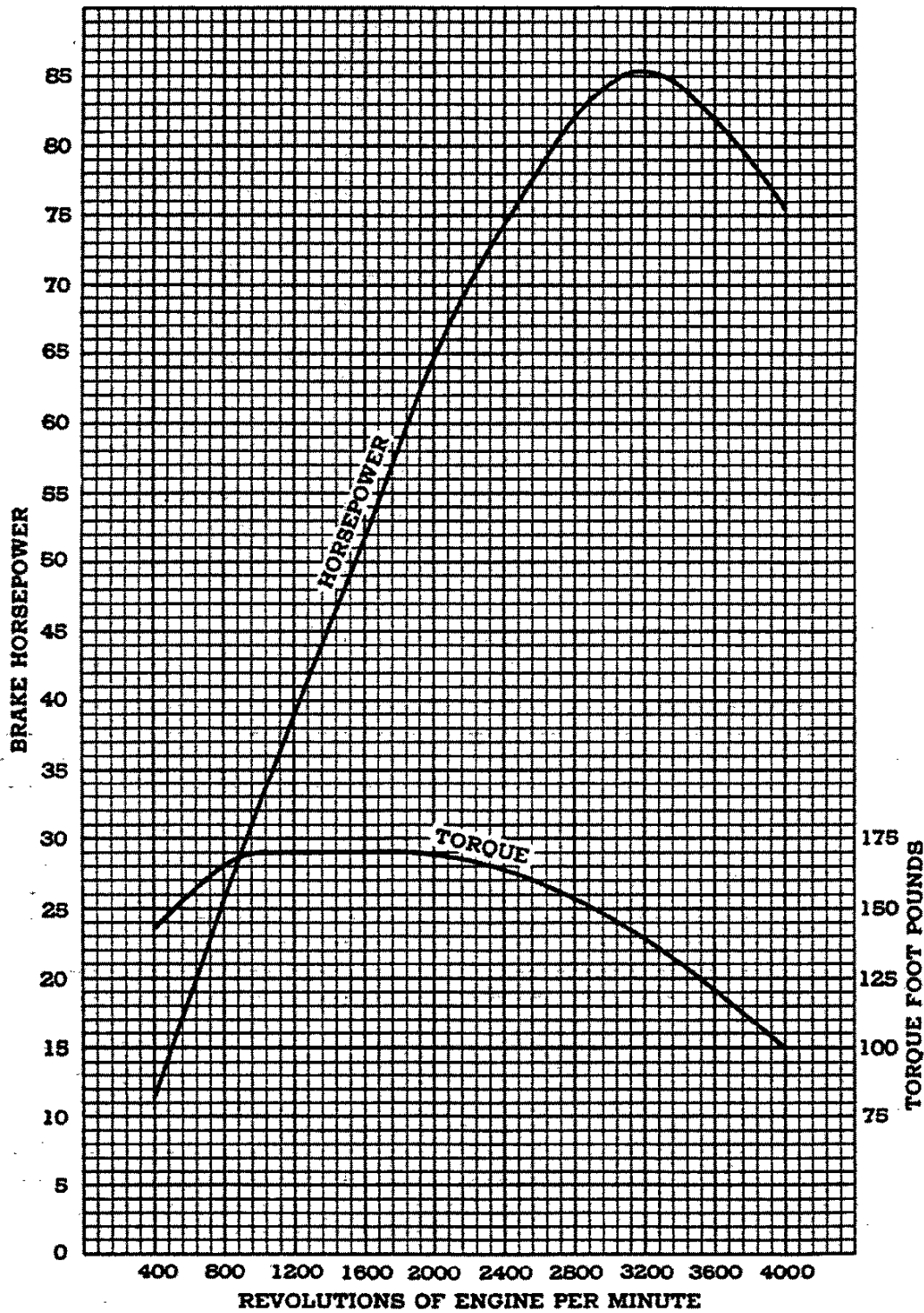

10-15-37

ENGINE

TRUCK POWER AND TORQUE

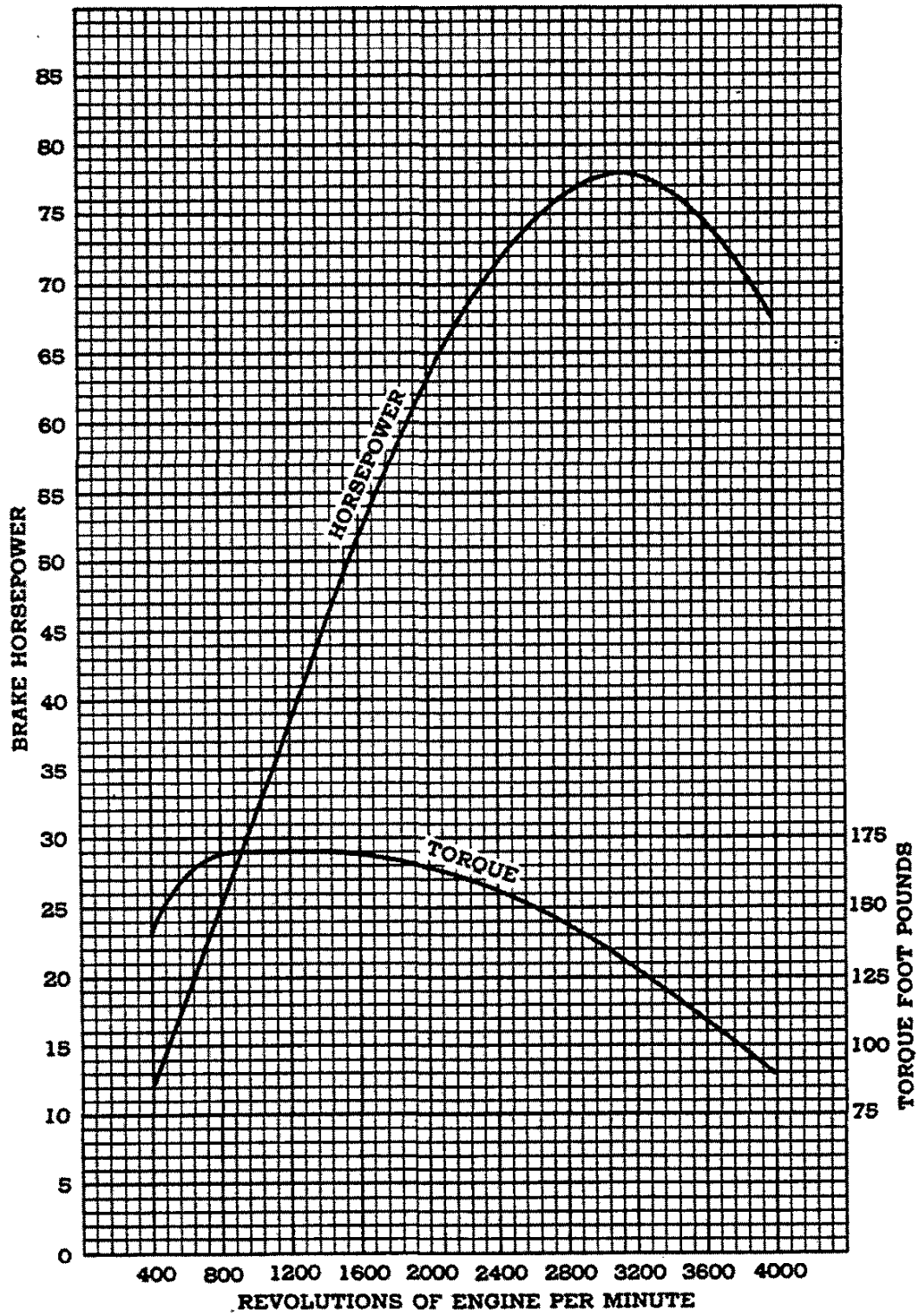

10-15-37

ENGINE



## ENGINE R.P.M. AND PISTON SPEED

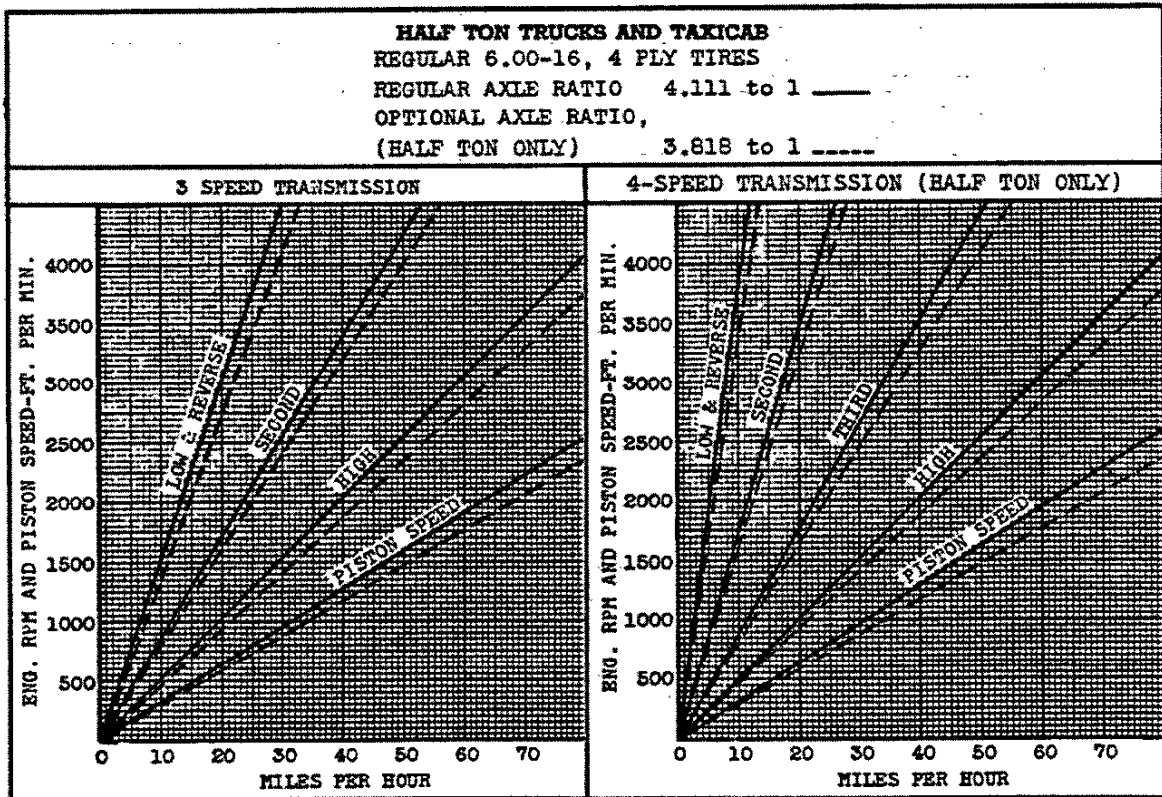
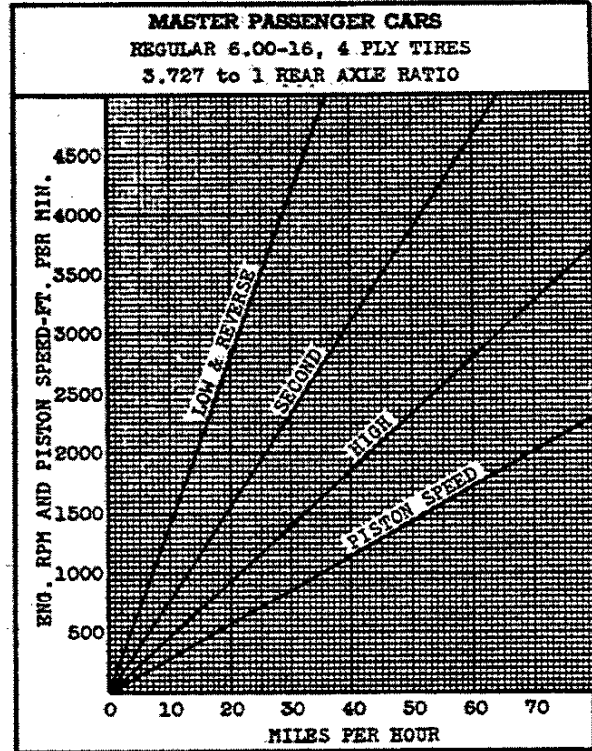
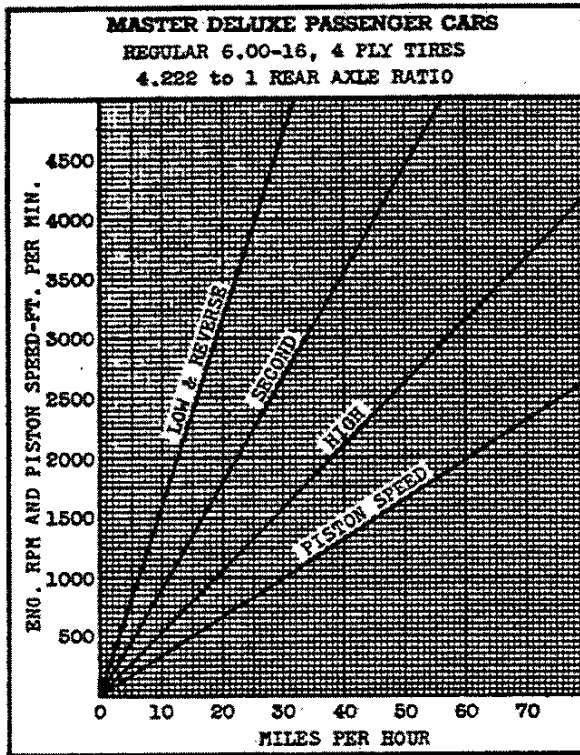

10-15-37 - 1-21-38 - Taxicab added.

## ENGINE R.P.M. AND PISTON SPEED—Continued

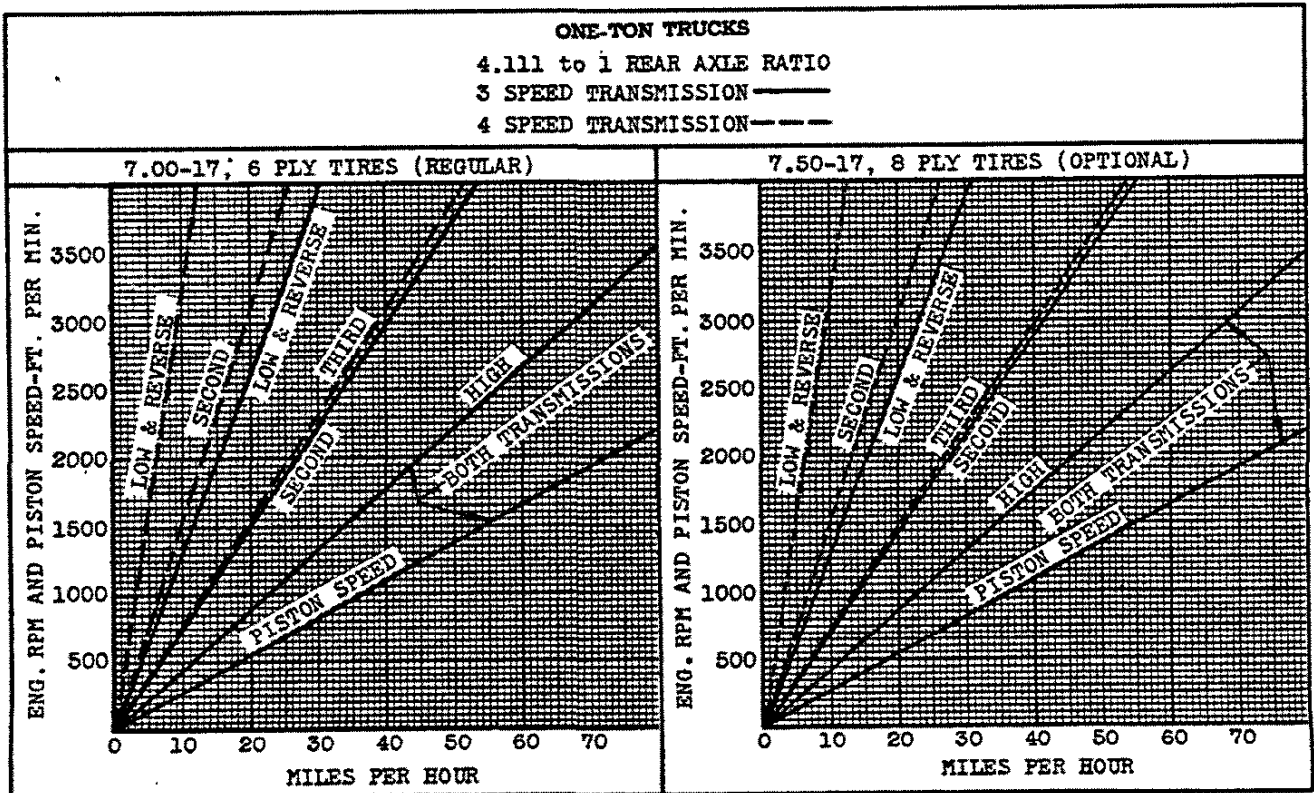
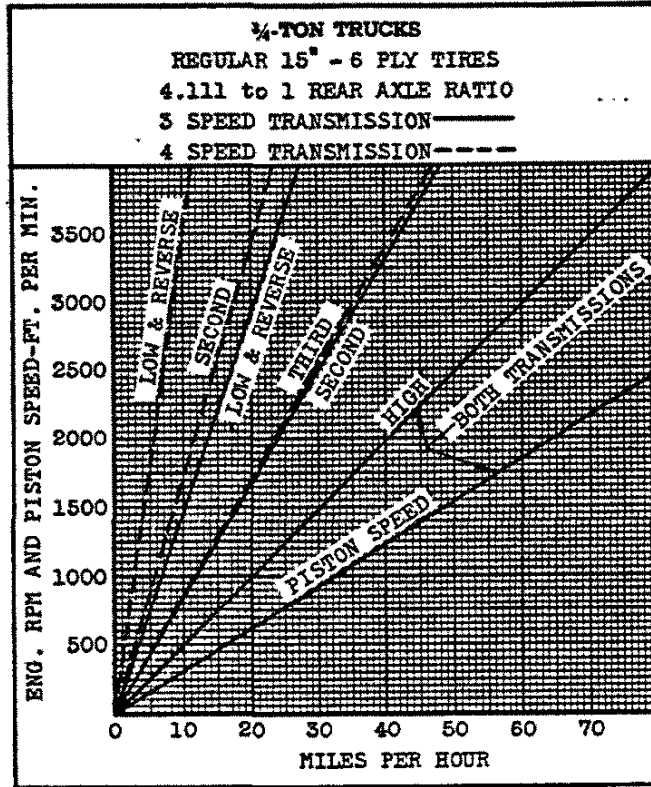

10-15-37

## ENGINE R.P.M. AND PISTON SPEED—Continued

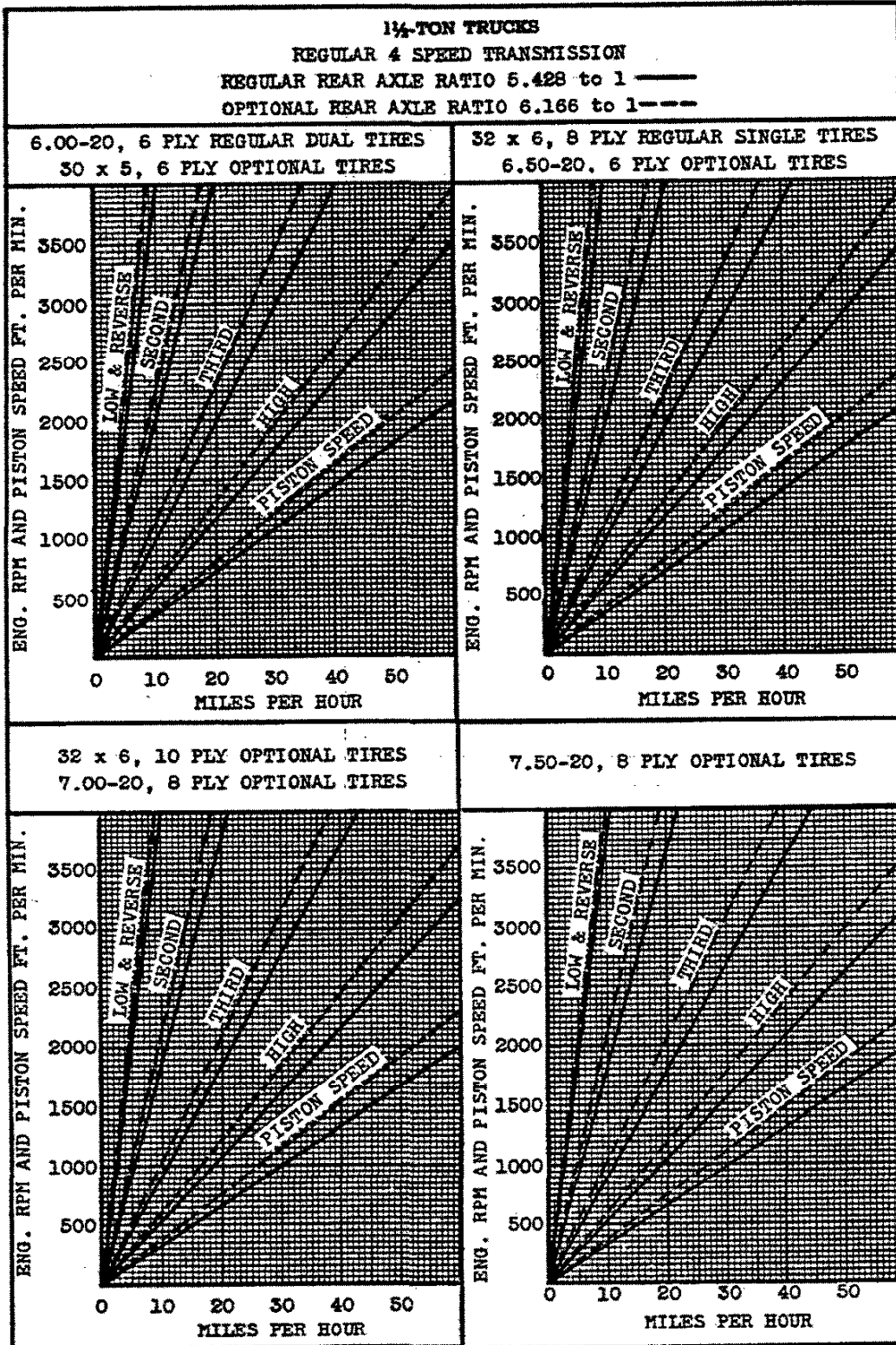

**SCHOOL BUS CHASSIS**

Regular equipment includes 6.166 rear axle ratio and 32 x 6-8 ply tires (Dual Rear). Optional equipment - 32 x 6-10 ply tires (Dual Rear). See above charts for Engine R.P.M. and Piston Speed.

10-15-37, 1-21-38 - School Bus chassis added.

## PISTONS

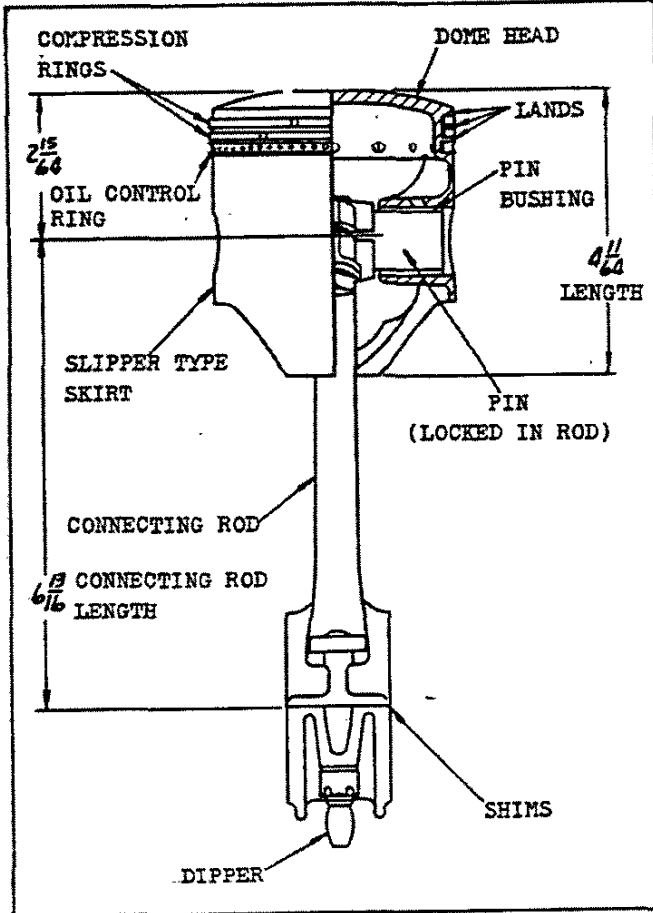

### PISTONS

Type ..... Slipper skirt, dome head  
 Material ..... Cast iron tin plated  
 Dia. clearance at lands .... .0145"-.019" cold  
 Compression ring groove depth .... .150"-.162"  
 Dia. clearance at skirt .... .0015"-.003" cold  
 Oil ring groove depth ..... .173"-.183"  
 Oil ring groove holes ..... 14, 5/32" drill  
 Side wall thickness-Pass. .... .0347"-.0447"  
 -Truck ..... .040"-.050"  
 Head thickness ..... .161"-.171"  
 Pin bushings-type ..... Pressed in piston  
 -material ..... Bronze  
 -O.D. .... .983"-.984"  
 -length (each) ..... 15/16"  
 -finish ..... Diamond bore  
 -weight (each) ..... .050#  
 Piston wt. without bushings-Pass. .... 1.42#  
 -Truck ..... 1.56#  
 Weight of piston, bushings, rings, pin and conn.  
 rod upper end x 6 - Pass. .... 14.40#  
 - Truck ..... 15.24#

### PISTON PINS

Diameter (chrome plated) ..... .8645" - .8650"  
 Length ..... 3.135"-3.165"  
 Taper limit in full length ..... .0002"  
 Weight (each) ..... .32#  
 Clearance in bushing ..... Slip fit

PISTON RINGS	COMPRESSION	OIL CONTROL
	Cast iron	
Material	Cast iron	
Type	Plain	Drilled or slotted
Number	2	1
Arrangement	Upper two rings	Under compression rings
Width	.1235"-.1240"	.1860"-.1865"
Wall thickness	.155" max.	.155" max.
Gap clearance	.005"-.015"	.005"-.015"
Ring clearance in groove	.0015"-.003"	.002"-.0035"
Weight (each)	.05 lbs.	.06 lbs.

## CONNECTING RODS

Type ..... Pin clamped in rod  
 Material ..... Drop forged steel  
 Crank pin diameter ..... 2.311"-2.312"  
 Crank pin length ..... 1.4985"-1.5015"  
 Width at piston pin ..... 1-1/8"  
 Lower end brg.-type ..... Centrifugally cast  
 -diameter ..... 2.3130"-2.3135"  
 -length ..... 1-5/16"  
 -material ..... Babbitt  
 -finish ..... Diamond bore  
 -clearance on dia. .... .001"-.0025"  
 Lower end bearing area-  
 Projected ..... 18.39 sq.in.  
 Circumferential ..... 57.7 sq.in.  
 Shims-type & material ..... Solid brass  
 Weight conn. rod assy. (each) ..... 1.77#  
 Upper end (each) ..... .4#  
 Lower end (each) ..... 1.37#  
 Total rotating weight (lower end x 6) .... 8.22#  
 Connecting rod assembly center of gravity from  
 wrist pin center ..... 5.273"  
 Connecting rod end play ..... .0065"-.0135"

10-15-37, 1-21-38 - Lower end bearing diameter revised.

## ENGINE

## CRANKSHAFT

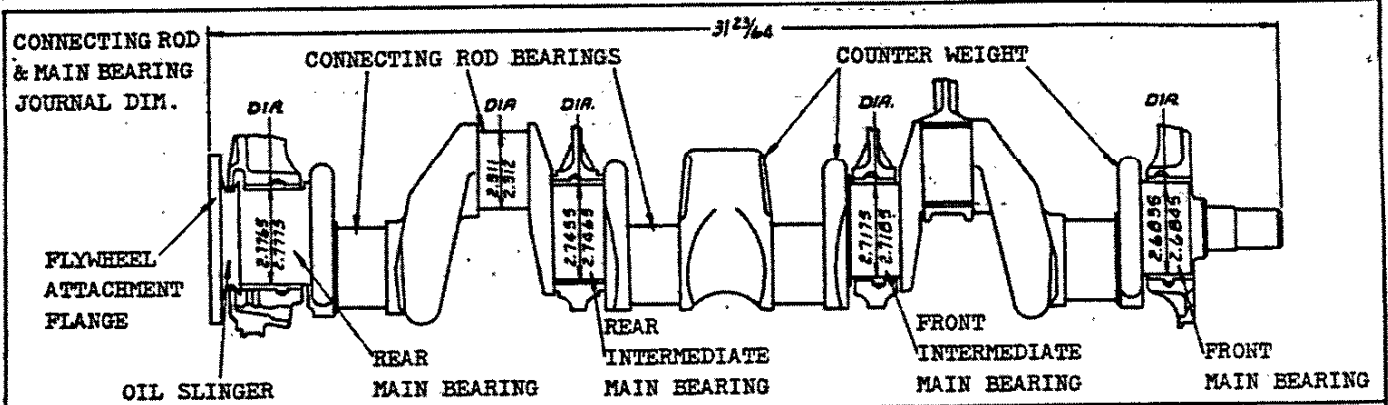

CRANKSHAFT		MAIN BEARINGS	
Type	4 bearings, 7 counterweights	Number	4
Material	Drop-forged steel	Type	Removable
Weight	68#	Material	Steel-backed babbitt
Offset	None	Clearance	.002"-.004"
End play	.004"-.007"	Thrust taken on	Rear intermediate bearing
Clearance between oil thrower groove in crankshaft and flange on cylinder block	.002"-.030"	Total effective bearing area:	
Harmonic balancer type	Oscillating	Projected	13.41 sq.in.
Crankshaft pulley dia.	6-1/32"	Circumferential	42.12 sq.in.
		Shim-type	Solid
		-material	Alloy aluminum & brass

MAIN BEARINGS	FRONT	FRONT INTERMEDIATE	REAR INTERMEDIATE	REAR
Inside diameter	2.6865"-2.6875"	2.7175"-2.7185"	2.7485"-2.7495"	2.7795"-2.7805"
Effective length	1"	1"	1"	1-11/32"
Total length	1-3/16"	1-3/16"	1-7/16"	1-5/8"

## CAMSHAFT

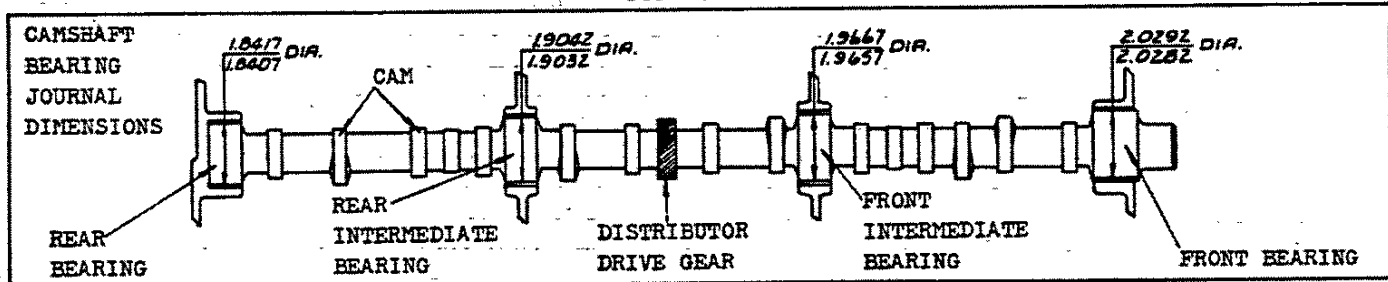

CAMSHAFT		CAMSHAFT BEARINGS	
Material	Drop-forged steel	Number	4
Drive type	Gear	Thrust taken on	Front bearing
Drive gear material	Bakelite & fabric comp.	Clearance on dia.	.0015"-.0035"
Crankshaft gear material	Steel	Effective bearing area:	
End play	Free - .003" max.	Projected	6.12 sq.in.
Camshaft ramp	.0111" inlet, .014" exh.	Circumferential	19.21 sq.in.

CAMSHAFT BEARINGS	FRONT	FRONT INTERMEDIATE	REAR INTERMEDIATE	REAR
Material	Steel-backed babbitt			
Inside diameter	2.0307"-2.0317"	1.9682"-1.9692"	1.9057"-1.9067"	1.8432"-1.8442"
Effective length	1"	13/16"	13/16"	13/16"
Total length	1-1/8"	15/16"	15/16"	15/16"

10-15-37

## ENGINE

## VALVES

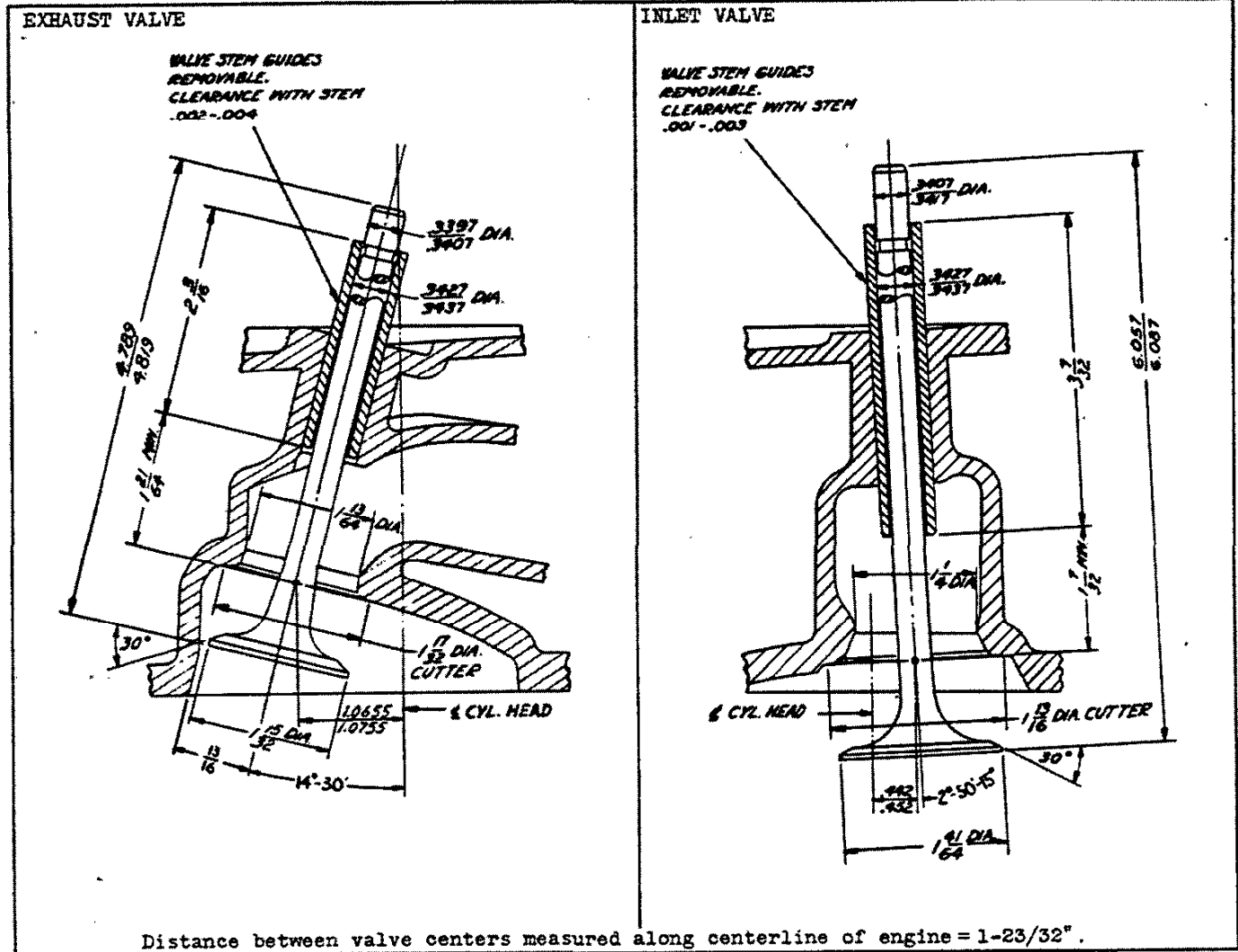

### VALVE DATA

Valve material ..... Extruded steel  
 Valve stem end style ..... Grooved for cup and cone  
 Valve lift-Exhaust ..... .3195"  
 -Inlet ..... .305"

### VALVE SPRING PRESSURE

Valve closed ..... 53#-59#  
 Valve open ..... 126#-134#

### VALVE SEAT

Material ..... Cast iron (cylinder head)  
 Cooling ..... Jets of water under pressure  
 Seat width in head -Exhaust ..... .069"-.093"  
 -Inlet ..... .035"-.060"

### VALVE ROCKER ARM

Ratio ..... 1.455 to 1  
 Bushing-Material ..... Cast bronze  
 -Opt. material ..... Steel-backed babbitt  
 -Diameter ..... .7925"-.7935"  
 -Length ..... 15/16"

### VALVE TAPPET

Type ..... Cylindrical  
 Material ..... Cast alloy iron  
 Outside diameter ..... .989"-.990"  
 Operating clearance -Exhaust ... .013"-.015" hot  
 -Inlet ..... .006"-.008" hot  
 Tappet lift-Exhaust ..... .2163"  
 -Inlet ..... .2062"

### CYLINDER HEAD

Type ..... Detachable Combustion chamber design ..... "Blue Flame"  
 Material ..... Cast alloy iron

10-15-37, 1-21-38 - Dimensions added to illustrations and valve spring pressures revised.

## LUBRICATION SYSTEM

Type ..... Pressure, pressure stream and splash.  
 MAIN BEARING lubrication ..... Direct pressure. Oil is pumped through drilled passages in cylinder case to main bearings.  
 CAMSHAFT BEARING lubrication ..... Direct pressure through passages from main brgs.  
 TIMING GEAR lubrication ..... Gravity feed from camshaft front bearing overflow.  
 CONN. ROD BRG. lubrication ..... By dippers at low speeds. By pressure streams at high.  
 CYLINDER BORE lubrication ..... Splash  
 PISTON PIN lubrication ..... Splash  
 VALVE MECHANISM lubrication ... Pressure. Pipe from low pressure side of distributor carries oil to valve rocker arms, springs,

valve stems and push rod upper ends.  
 WATER PUMP lubrication ..... Permanently lubricated, sealed ball bearing.  
 Oil pump type ..... Gear  
 Oil pump drive ..... From camshaft  
 Normal oil pressure .... 13.5# @ 2621 RPM  
 Oil pressure relief valve opens at .... 75#  
 Oil cleaner type ..... Screen with by-pass on intake side of oil pump.  
 Oil drain type .... Plug in side of oil pan.  
 Crankcase ventilator type ..... Suction  
 Oil filler ..... Combined with ventilator  
 Oil screen area ..... 18.3 sq. in.  
 Oil level gauge type ..... Rod  
 Oil pan capacity (dry) ..... 5-1/2 quarts  
 Oil pan capacity (for refill) .... 5 quarts

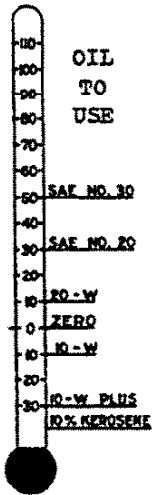

## COOLING SYSTEM

ITEM	PASSENGER CARS		TRUCKS		HEAVY DUTY CORE	
	MASTER DELUXE	MASTER & TAXICAB	HALF, 3/4 & ONE TON	1-1/2 TON & SCHOOL BUS	3/4, ONE, 1-1/2 & SCHOOL BUS	
Cooling system capacity	14 quarts				16	
Radiator core	Make and type	Harrison, ribbed cellular				
	Material	All copper				
	Size	.222"x.556"x2"	.25"x.556"x2"	.25"x.560"x2"	.20"x.560"x2"	.20"x.560"x3"
	Exp. core area	368.5 sq.in.		405 sq.in.		
Fan shroud	None			Yes		
Radiator hose	Type	Conventional rubber. Outlet consists of two hose joined by steel tube.				
	Location	Inlet	From cylinder head to core			
		Outlet	From core to water pump			
	Size	Inlet	1-1/4" I.D. x 5-5/8" long	1-1/4" I.D. x 6-1/4" long		
Outlet		UPPERHOSE: 1-1/2" I.D. x 2-3/4". LOWERHOSE: 1-1/2" I.D. x 5".				
Water thermostat	Make and location	Harrison - In cylinder head outlet.				
	Type	Bellows operating poppet valve				
	Valve action	Valve starts to open at 140°-145° F. and is fully open at 170° F., 29" Hg. barometric pressure.				
Engine fan	Type	Four staggered blades				
	Diameter	15-3/4"	16-1/4"			
	Fan pulley	28° v - 4-21/64" diameter				
	Ratio to Eng. Speed	1.393:1				
	Core clearance	8/16"				
	Fan belt	Make	Various			
		Material	One piece vulcanized fabric			
Size		11/16" max. width x 42-7/8" around outside				
Water pump	Type and drive	Centrifugal - By fan belt				
	Location	On front of cylinder and case				
	Capacity	47 gallons per minute @ 4000 engine RPM				
	Impeller type	Vane				
	Bearing	Type	Double row ball, sealed			
		O.D.	1.1806"-1.1811"			
		Length	1-21/32"			
	Seal	Material	Graphite impregnated bakelite and fabric composition			
Adj.		Automatic - By spring tension				

10-15-37, 1-21-38 - Water Pump data revised. Taxicab and School Bus added.

## ENGINE



# CHEVROLET 1938 SPECIFICATIONS

## FUEL SYSTEM

### FUEL PUMP

Make ..... AC  
 Model ..... AF  
 Type ..... Mechanical  
 Drive ..... From camshaft  
 Arm throw at camshaft ..... 1/4"  
 Inlet and outlet air dome ..... Yes  
 Fuel filter ..... Screw on dome

### AIR CLEANER

Make ..... AC  
 Type ..... Combined with silencer & flame arrester

### FUEL MIXTURE

Heated..... Yes. Passes through manifold heat chamber, automatically controlled by thermostat on manifold.

### CARBURETOR









Make and model ..... Carter W1  
 Type ..... Single adjustment, down-draft  
 Size ..... 1-1/4"  
 Accelerator pump ..... Yes  
 Float level .... When closed, top of float measures 3/8" below finished surface of cover.

### FUEL GAUGE

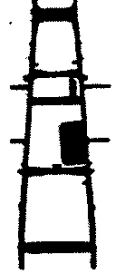
Make ..... AC  
 Type ..... Electric

### OCTANE SELECTOR

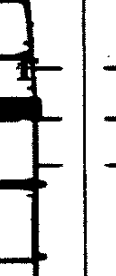
Type ..... Manual  
 Range ..... 20° Vernier

FUEL TANK	PASSENGER CARS		TRUCKS					
	Chassis, Spt. Sedan, Coa., Spt. Coupe, Sed., Town Sed., Taxi, Cabriolet	Business Coupe, Master-Sedan Delivery	HALF TON		3/4 TON & ONE TON		SCHOOL BUS & 1-1/2 TON	
			Chassis and Cowl, Panels, Canopy Exp., Carryall Suburban	Chassis and Cab, Pickup truck	Chassis and Cowl, Panel truck	Chassis and Cab, Stake and Pickup truck	School Bus & 1-1/2 Ton Chassis and Cowl	1-1/2 Ton Chassis & Cab, Pick-up, Panels, Stakes
Location								
Mounting	Suspended in chassis between two rear cross members.	Clamped to underbody below floor just behind seat	Clamped to right side rail ahead of rear fender	Clamped to cab floor directly under cab seat	Clamped to right side rail ahead of rear fender	Clamped to cab floor directly under cab seat	3-point mounting to frame below seat position	Clamped to body floor directly under seat
Type	Two stamped pans, seam-welded together							
Capacity	14 gallons	18 gallons	16 gallons	18 gallons				
Filler Location	Outside on right rear fender	Outside before right fender	Outside behind right side door	Outside at rear corner	Outside behind panel right door	Outside at right rear cab corner	At right side of chassis	Outside at right rear cab corner

## EXHAUST SYSTEM

ITEM	PASSENGER CARS	TRUCKS
Muffler type	Diffusion and resonance (5 tube reverse flow)	
Diameter x length	6-1/16" x 18"	
Muffler mounting	Single point rubber	
Exhaust pipe diameter	1-7/8"	
Tail pipe diameter	1-3/4"	1-1/2"

10-15-37, 1-21-38 - Taxicab and School Bus added.

## ENGINE



ENGINE ELECTRICAL SYSTEM										
GENERATOR	PASSENGER CARS					TRUCKS				
	MAS. DELUXE	MASTER	TAXI	HALF TON	3/4 TON	1 TON	1-1/2 TON	S. BUS		
Make	Delco-Remy									
Model	#110004					#948-R				
Ventilated by	Fan built into generator pulley									
Driven by	"V" belt									
Generator pulley	Type	28° V								
	Diameter	3-11/32"								
Speed ratio-generator to engine	1.80:1									
Amperes -cold	Lights off	26-30					15			
	Lights on	26-30					18-21			
Maximum charging rate-cold	Voltage	8					8.2			
	RPM	3400					2600			
	Car speed MPH	36.0	40.8	36.9	28.3	28.9	32.3	25.5	22.5	
Amperes -hot	Lights off	25-28					14			
	Lights on	25-28					15-18			
Maximum charging rate-hot	Voltage	8					8.1			
	RPM	3600					2800			
	Car speed MPH	38.1	43.2	39.1	30.5	31.1	34.8	27.5	24.2	
Thermostat	None									
Field fuse	None									
Voltage regulator type	Vibrator					None				
Rated voltage	6-8									
Brush tension	14-18 oz.									
Rotation (Drive end)	Clockwise									
Bearings	Commutator end	Bronze bushing								
	Drive end	Ball								
Cut-out	Voltage at closing	6.5-7.0					7.2			
	Armature speed	800 RPM								
	Car speed at closing MPH	8.48	9.60	8.69	8.71	8.89	9.94	7.86	6.92	
	Amperes to open	0-3.0					1.5			

### IGNITION

Type ..... Separate units, high tension distributor ground return system  
 Make & Model ..... Delco-Remy #110008  
 Current source ..... Generator  
 Spark control type ..... Full automatic  
 Spark advance-vacuum ..... 15°  
 -automatic ..... 42° - 50°

Timing spark advance ..... 5° B.T.C.  
 Firing order ..... 1-5-3-6-2-4  
 Distributor interrupter point opening .018"-.024"  
 Distributor bearings material ..... Cast iron

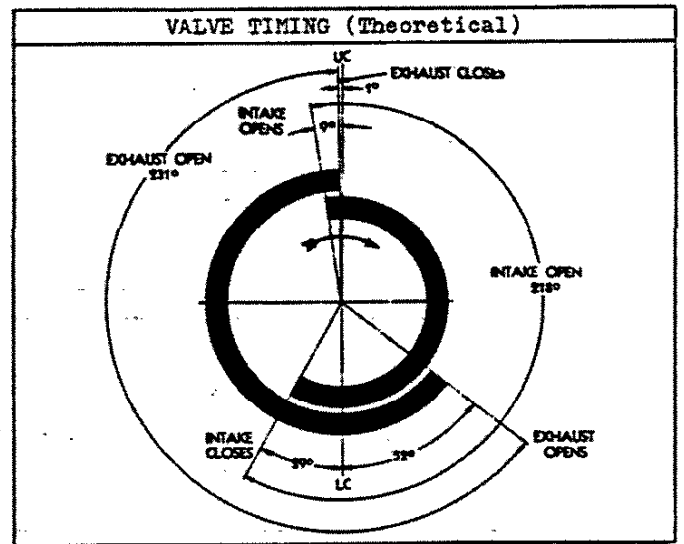
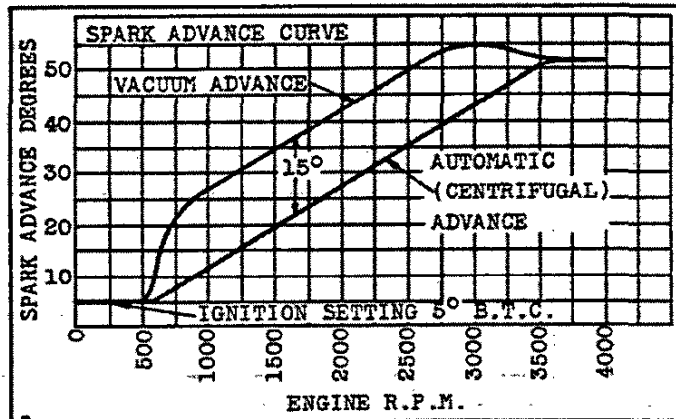

10-15-37, 1-21-38 - Taxicab and School Bus added. Car speed MPH revised. New spark advance chart.

### ENGINE

## ENGINE ELECTRICAL SYSTEM—Continued

### IGNITION - Continued

Ignition lock type ..... Armored cable  
 from coil to dash and lock switch  
 Condenser make ..... Delco-Remy  
 Coil location ..... On right side of engine  
 Coil Amps. drawn - Engine stopped ..... 4.8  
                             - Engine idling ..... 2.5  
 Spark plug-make and size ..... AC 46  
     -thread size ..... 14 mm.  
     -recommended gap ..... .040"

### STARTING MOTOR

Make ..... Delco-Remy  
 Model ..... 1107001  
 Type of drive ..... Mechanical  
 Rotation (commutator end) .... Counter-clockwise

Bearings-commutator end ..... Cast Iron  
     -drive end ... Graphite lubricated bushing  
 Lock test-amperage draw ..... 525  
     -volts ..... 3.4  
     -torque ..... 14 ft.lb.  
 No load test-amperage draw ..... 125  
     -volts ..... 5.4  
     -RPM ..... 2500  
 Pinion meshes ..... On front of flywheel  
 Pinion teeth ..... 9  
 Flywheel teeth ..... 139  
 Pinion to flywheel ratio ..... 15.44:1  
 Normal engine cranking speed ..... 65 RPM  
 Starter ..... Direct foot-actuated control  
 Starter to throttle connection ..... Lug on cross  
     shaft engages accelerator shaft. Pass. cars only.

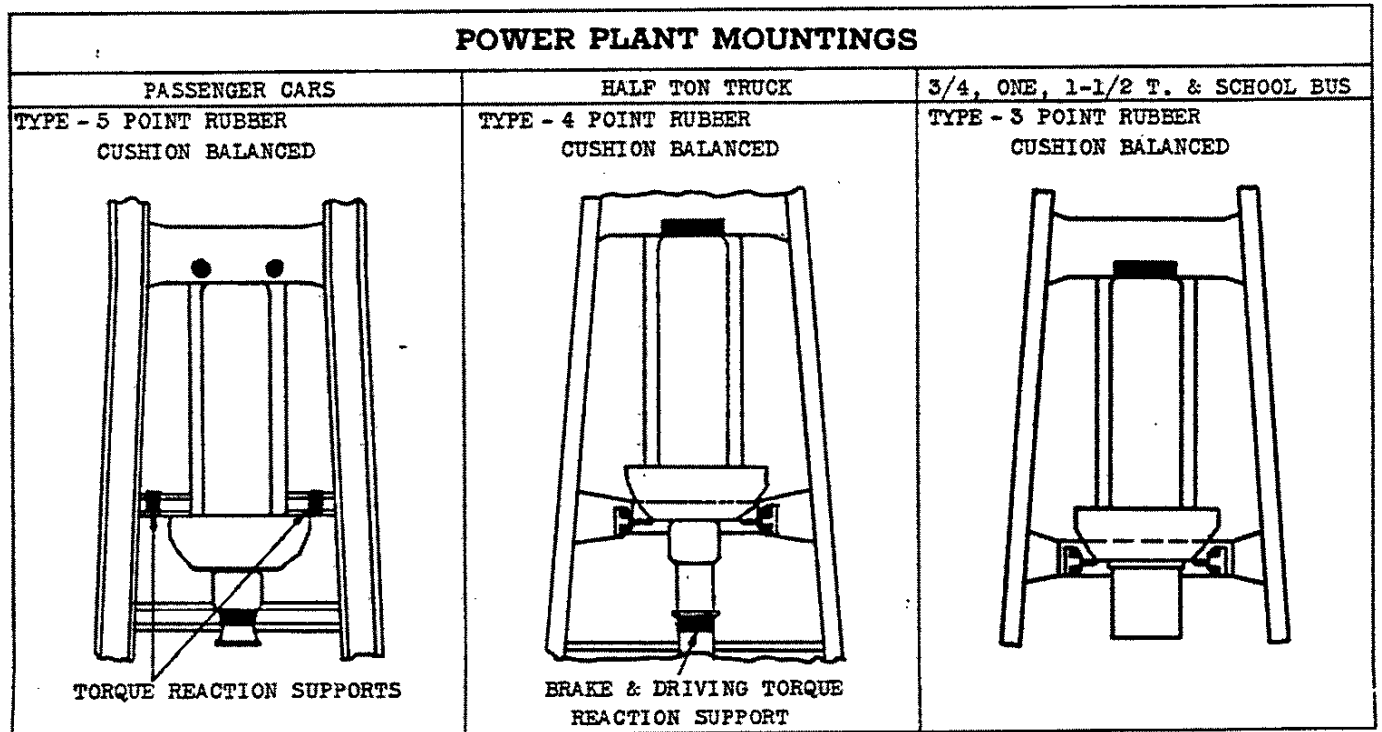

10-15-37, 1-21-38 - Taxicab and School Bus added.

## ENGINE

## CLUTCH

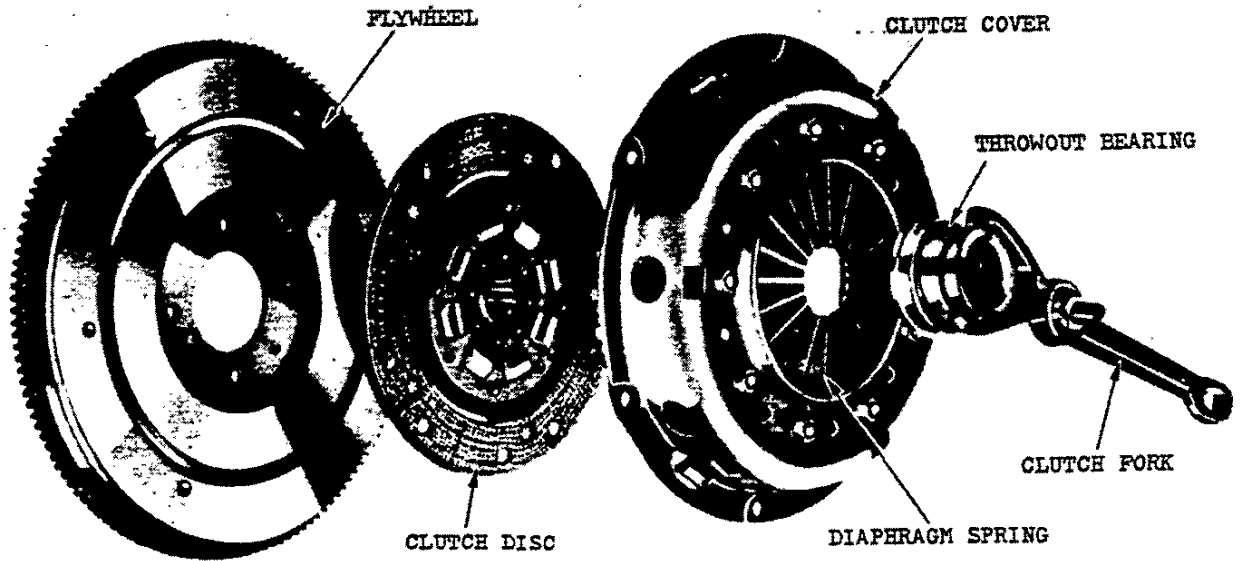

ITEM	PASSENGER CARS	TRUCKS		
		HALF TON	3/4, ONE, 1-1/2 & S.BUS	
Type	Single dry plate			
Rated torque capacity	192 ft.lb.			
Spring	Number and type	Single - Diaphragm		
	Pressure	1070#-1310#		
	Material	Spring steel - Heat treated		
	Pressure levers	18 integral with spring		
Drive	Through radial lugs			
Discs	Driving	Flywheel and pressure plate		
	Driven - number	One		
	Vibration insulation	Cushion springs at hub		
	Facing	Material	Woven and formed - Asbestos composition	
		O.D. & I.D.	9" - 6-1/4"	10-3/4" - 7"
Area		65.87 sq.in.	104.6 sq.in.	
Thickness	.122"-.128"			
Bearings	Throwout	Type	Special ball - mounted on sleeve	
		Lubrication	Packed for life	
	Pilot	Type	Ball - New Departure - 907109	
		Lubrication	Packed for life	
Controls	Clutch fork - type	Drop forged-pivot mounted on ball		
	Pedal mounting	On brake main cylinder	On clutch housing	
Flywheel	Material	Cast Iron		
	Weight (with ring gear)	31.5#		
	Ring gear type	Steel-shrunk on		
	Ring gear teeth	139 teeth - 1/2" wide		
Attachment to flywheel	6 bolts	9 bolts		

10-15-37, 1-21-38 - Taxicab and School Bus added.

## TRANSMISSION

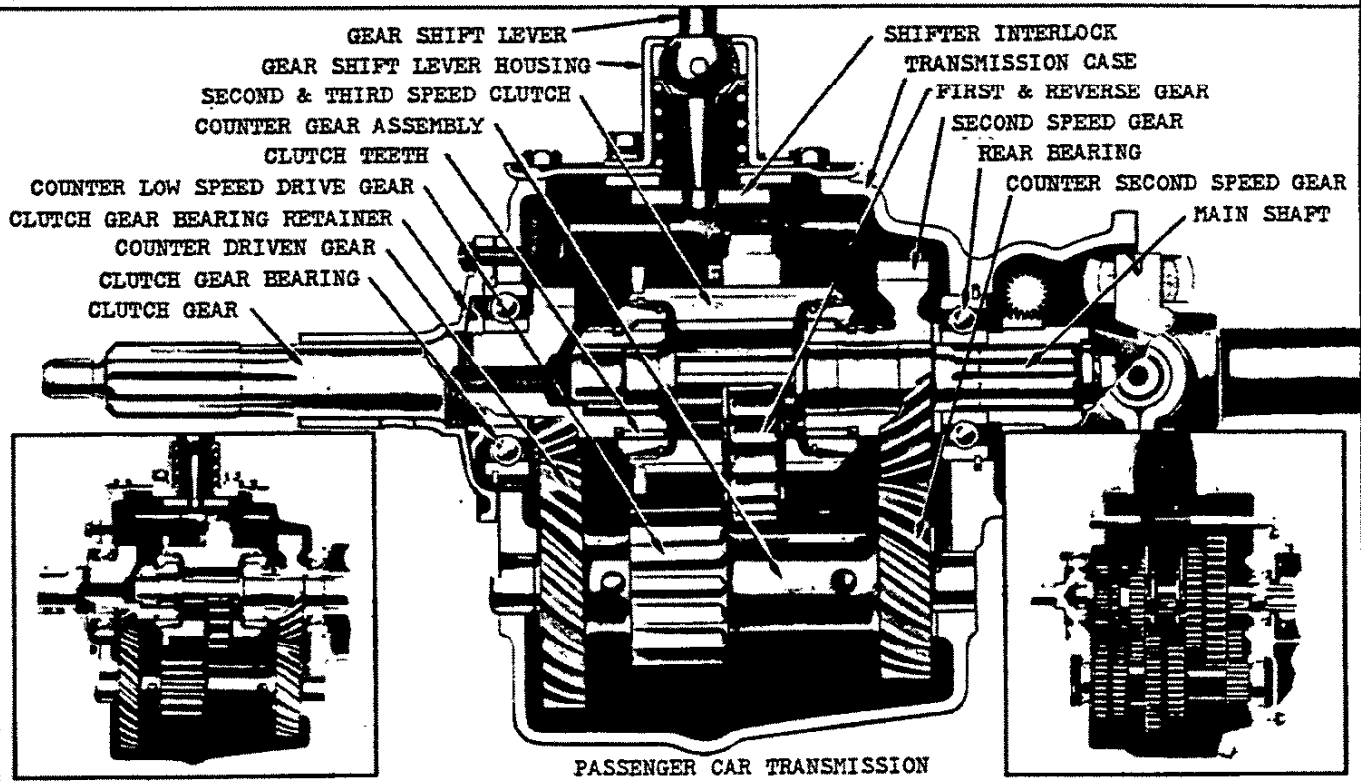

PASSENGER CAR TRANSMISSION

1/2 - 3/4 - 1 TON TRANSMISSION

1-1/2 TON, SCHOOL BUS TRANS.

ITEM		PASSENGERS CARS, HALF, 3/4 & ONE TON	1-1/2 TON & SCHOOL BUS
Transmission location		In unit with engine	
Type		Selective synchro-mesh, silent second	Conventional
Shift type		Standard	
Number of speeds		3 forward, 1 reverse	4 forward, 1 reverse
Constant mesh gears type		Helical	Spur
Synchronous meshing gears		Second and third	None
Torque capacity		192 ft.lb.	
Gear ratios & maximum torque of gear set at given ratio	First	2.94 = 474 ft.lb. @	7.226 = 1167 ft.lb. @
	Second	1.68 = 271 ft.lb. @	3.478 = 561 ft.lb. @
	Third	Direct = 170 ft.lb.	1.711 = 276 ft.lb. @
	Fourth	None	Direct = 170 ft.lb.
	Reverse	2.94 = 474 ft.lb. @	7.148 = 1152 ft.lb. @
Bearings or Bushings	Reverse idler bushing	No. & Mat'l Two-bronze	Two-brass
		Size .7515"-.7525" I.D. x 1-1/16"*	.8772"-.8782" I.D. x 1-7/16"*
Main shaft bearing	Front	Hyatt #590752	Hyatt #141854
	Rear	N.D. #954168	N.D. #903307
Counter shaft brg. or bushing	Material	Bronze	Steel
	Size or part no.	Front .8772"-.8782" I.D. x 1-3/16"*	Hyatt #142260
		Rear .8772"-.8782" I.D. x 1-3/16"*	Hyatt #121856
Clutch gear brg. part no.		N.D. #954141	
Second speed gear bearing	Material	Chromium steel-hardened	None
	Size	1.062"-1.063" I.D. x 1-3/4"*	None
Power take-off	Type	None	6 bolt S.A.E. Standard
	Location	None	On left side
	Speed at 1000 Engine RPM	None	425
	Meshing gear	None	33 teeth

\* - Effective length. @ - 95% efficiency assumed.

10-15-37, 1-21-38 - Taxicab & School Bus added. Bushing dimensions revised.

## TRANSMISSION

## STEERING

### SECTOR TYPES

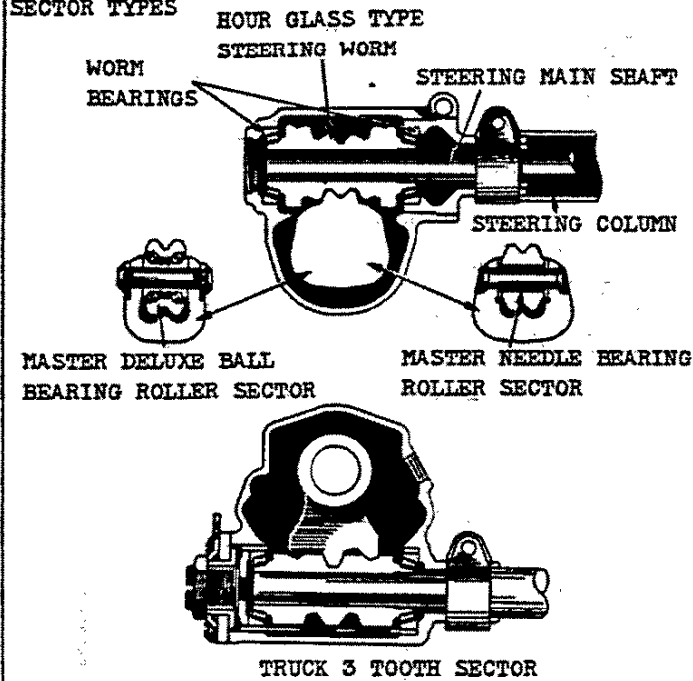

### TURNING DIAMETERS

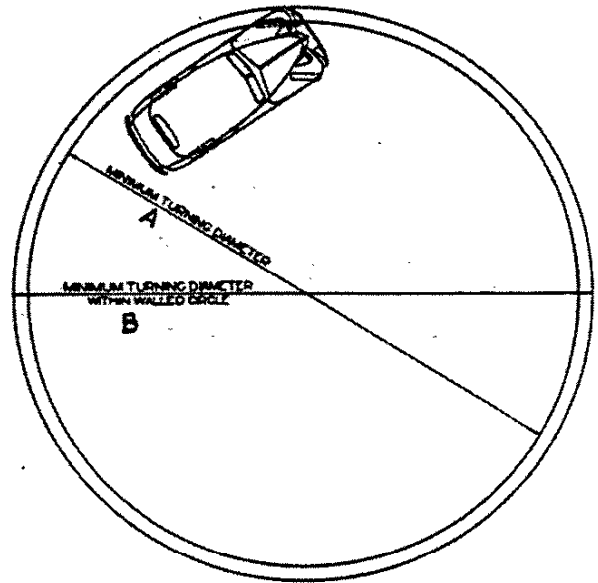

### SECTOR MOUNTING

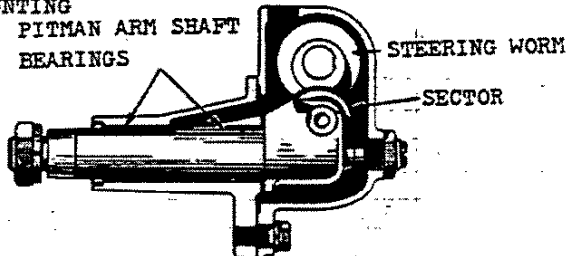

PASSENGER CAR OVERHUNG TYPE

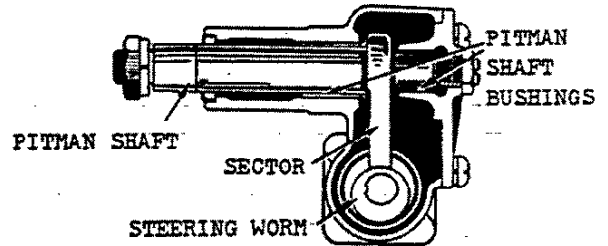

TRUCK STRADDLE MOUNTED TYPE

ITEM	PASSENGER CARS				TRUCKS				
	MASTER DELUXE	MASTER TAXI	HALF TON	3/4 TON	ONE TON	1-1/2 TON		SCHOOL BUS	
						131-1/2" W.B.	157" W.B.		
Steering gear type	Semi-reversible								
Steering gear ratio	17-1/2:1	19:1	16:1						
Bearings & sector brg.	Steering worm bearing		Special tapered roller #261866						
	Roller	Type	Ball	Needle	None				
Bushings	Size or No.	#262605	.077" x .947"	None					
	Pitman Shaft	Material	Bimetal		Cast bronze				
	Bushings	Size	1.125"-1.256" I.D. x 1-1/2"		(Outer) 1.1245"-1.125" I.D. x 1-3/8" (Inner) .813"-.8135" I.D. x 7/8"				
Turning diameter	"A"	Right	38.5'	44'	38.5'	42.5'	42'	49.0'	56.5'
		Left	40'	44'	39.0'	44.5'	44'	51.0'	61.0'
	"B"	Right	40.75'		41.0'	45.5'	45'	51.5'	59.0'
		Left	42'	42.5'	41.5'	46.5'	46'	53.5'	63.5'
Steering wheel	Type	Three spoke, thin grip							
	Material	Hard rubber and steel							
	Diameter	17-5/16"				17"			
Main shaft diameter					3/4"				
Column diameter					1-1/2"				
Pitman shaft diameter					1-1/8"				

10-15-37, 1-21-38 - Taxicab & School Bus added.

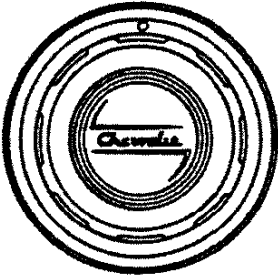
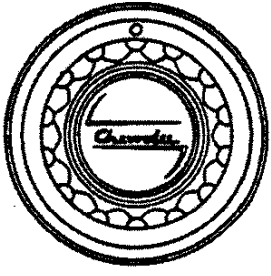
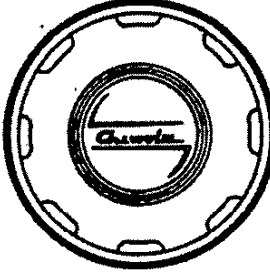
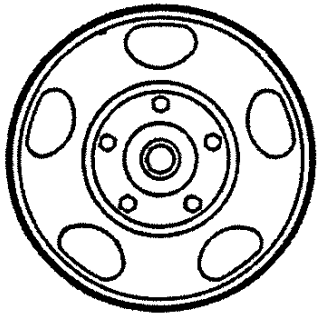
WHEELS			
PASSENGER CAR AND HALF TON TRUCK WHEEL	3/4 TON TRUCK WHEEL	ONE TON TRUCK WHEEL	1-1/2 TON TRUCK AND SCHOOL BUS WHEEL
			
TYPE: Steel, short spoke disc. RIM TYPE: Drop center, integral with wheel.	TYPE: Steel, short spoke disc. RIM TYPE: Drop center, integral with wheel.	TYPE: Steel, short spoke disc. RIM TYPE: Integral with wheel; separate lock ring.	TYPE: Steel, pierced disc. RIM TYPE: Integral with wheel; separate lock ring.

TIRES AVAILABLE									
MODEL	SIZE	RECOMMENDED PRESSURE		LOAD RATING		LOADED RADIUS	LOADED REVS.	WHEEL RIM	MAKE
		FRONT	REAR	FRONT	REAR	ROLLED	PER MILE	SIZE	
MASTER DELUXE, MASTER	6.00-16-4 ply, Regular	26#	28#	875#	915#	13.52"	746	16 x 4.00E	U.S. or Good-rich
	6.00-16-6 ply, Optional	28#	30#	915#	955#	13.53"	745	16 x 4.00E	
	5.50-18-4 ply, Optional	28#	30#	880#	940#	14.26"	707	18 x 3.62F	
TAXI-CAB	6.00-16-4 ply, Regular	26#	32#	875#	990#	13.52"	746	16 x 4.50E	U.S. or Fire-stone
	6.00-16-6 ply, Optional	28#	34#	915#	1030#	13.53"	745	16 x 4.50E	
	6.25-16-4 ply, Optional	23#	28#	875#	985#	13.53"	745	16 x 4.50E	
	6.25-16-6 ply, Optional	25#	30#	920#	1025#	13.53"	745	16 x 4.50E	
	6.50-16-6 ply, Optional	23#	28#	930#	1050#	13.53"	745	16 x 4.50E	
HALF TON	6.00-16-4 ply, Regular	28#	32#	915#	990#	13.52"	746	16 x 4.00E	U.S. or Good-rich
	6.00-16-6 ply, Optional	30#	40#	955#	1130#	13.53"	745	16 x 4.00E	
	15"-6 ply, Optional	15#-20#	15#-25#	960# to 1300#	960# to 1500#	13.92"	724	15 x 5.50F	
3/4 TON	5.50-18-4 ply, Optional	28#	32#	970#	1050#	14.26"	707	18 x 3.62F	
ONE TON	15"-6 ply, Regular	15#-20#	35#	960# to 1300#	1500#	13.95"	724	15 x 5.50F	
	7.70-17-6 ply, Regular	45#		1550#		15.41"	654	17 x 6(4.33R)	
	7.50-17-8 ply, Opt. rear	None	55#	None	1950#	15.80"	638	17 x 6(4.33R)	
1-1/2 T.	See next page								
SCHOOL BUS	32 x 6-8 ply, Regular	75#		1950#		16.14"	625	20 x 5(3.75P)	
	32 x 6-10 ply, Optional	80#		2200#		16.62"	600	20 x 6(4.33R)	

NOTE: Use of optional tires may necessitate changes in equipment such as wheels, speedometer gears, wheel carrier, springs, rear axle (for ratio), engine fan, and radiator core according to the various established Exception Groupings.

10-15-37, 1-21-38 - Taxicab & School Bus added.

## WHEELS AND TIRES

# CHEVROLET 1938 SPECIFICATIONS

55

TIRES AVAILABLE—1½-TON TRUCKS							
REAR		FRONT					
		6.00-20-6 5" R, 4-1/8" O Regular	6.50-20-6 5" R, 4-1/8" O Opt. 379	7.00-20-8 6" R, 4-1/2" O Opt. 386	30 x 5-6 5" R, 4-1/8" O Opt. 373	32 x 6-8 5" R, 4-1/8" O Opt. 377	32 x 6-10 6" R, 4-1/2" O Opt. 383
S I N G L E	32 x 6-8 ply 5" Rim, 4-1/8" Offset Regular	Regular			Opt. 373	Opt. 377	
	32 x 6-10 ply 6" Rim, 4-1/2" Offset Option 384	Regular	Opt. 379	Opt. 386	Opt. 373	Opt. 377	Opt. 383
	6.50-20-6 ply 5" Rim, 4-1/8" Offset Option 380	Regular	Opt. 379				
	7.00-20-8 ply 6" Rim, 4-1/2" Offset Option 387	Regular	Opt. 379	Opt. 386			
D U A L	6.00-20-6 ply 5" Rim, 4-1/8" Offset Regular	Regular					
	30 x 5-6 ply 5" Rim, 4-1/8" Offset Option 374				Opt. 373		
	32 x 6-8 ply 5" Rim, 4-1/8" Offset Option 378	Regular			Opt. 373	Opt. 377	
	32 x 6-10 ply 6" Rim, 4-1/2" Offset Option 385-350 @	Regular	Opt. 379	Opt. 386	Opt. 373	Opt. 377	Opt. 383
	6.50-20-6 ply 5" Rim, 4-1/8" Offset Option 381	Regular	Opt. 379				
	7.00-20-8 ply 6" Rim, 4-1/2" Offset Option 388 @	Regular	Opt. 379	Opt. 386			
	7.50-20-8 ply 6" Rim, 4-1/2" Offset Option 408-350 @@	Regular	Opt. 379	Opt. 386			

**NOTES**

R - Rim size  
 O - Wheel offset  
 @ - Panel with light rear springs  
 @@ - Auxiliary springs (Opt. 350)  
 used with Option 385 and 408  
 RIM SIZES: 5" = 3.75 P, 6" = 4.33 R  
 as per Tire and Rim Association  
 standards.

**USE OF CHART**

To determine the correct front tires for use with either single or dual rear tires, locate the size rear tire recommended for a given load. Then by reading across the page, locate the front tire options available with the particular rear tire

used. Select the correct size front tire based on the gross allowable weight and operating conditions. Never use a larger tire in front than in rear nor high pressure tires in front with balloon rear tires.

TIRE RATINGS—1½-TON TRUCKS				
Size	Pressure	Load Rating	Loaded Radius Rolled	Loaded revs. per mile
6.00-20-6 ply	45#	1400#	15.68"	643
30 x 5-6 ply	70#	1600#	15.68"	643
6.50-20-6 ply	50#	1700#	16.14"	625
32 x 6-8 ply	75#	1950#	16.14"	625
7.00-20-8 ply	55#	1950#	16.82"	600
32 x 6-10 ply	80#	2200#	16.82"	600
7.50-20-8 ply	55#	2200#	17.33"	581

10-15-37

**WHEELS AND TIRES**

BATTERY AND LIGHTS			
ITEM	PASSENGER CARS		TRUCKS
	MAS. DELUXE & MASTER	TAXICAB	
Battery	Make and model		Delco, 17M-W, 17 plates
	Size, l. x w. x h.		10-8/16" x 7" x 7-7/16"
	Volts and capacity		6 volts, 100 amp. hrs.
	Charging rate		6 volts start, 5 volts finish
	Cell arrangement		Three, side to side
	Terminal grounded		Negative
Battery mounted on		Frame right side	
Head-lamps	Type, dia., length		Two beam, 7-15/16", 14-17/32"
	Lens	Type & dia.	Guide, 6-1/2"
	Bulb	Type & size	Two filament, #2320L
		Candle power	32 upper beam - 21 lower beam
	Reflector type	Tiltray	
Dimmed by	Depressed beam operated by foot switch		
Parking light	Location		In each headlamp
	Size and candle power		#55, 1-1/2
Tail and stop lamp	Number used		One (Master and Taxicab) Two (Master Deluxe and Master Cabriolet)
	Type		Combined in one assembly
	Size	Tail light	#63, 3
	& C.P.	Stop light	#63, 3
Stop light operation	Hydraulic switch on brake main cylinder		
Instrument cluster	Number of lights		Two
	Size & candle power		#55, 1-1/2
Ignition lock light	Size		#51
	Candle power		1
Rear door tell-tale light	Location, number used		None
	Size & candle power		Instrument panel, one #64, 3
	Jewel color		Red
	Switch location		Rear door
Vacant lamp	Location		Front of roof
	Number of lights		Three
	Size & candle power		#64, 3
	Switch location		Instrument panel and Taximeter
Dome light	Used in		All bodies except Cabriolet
	Size		#81
	Candle power		#6
	Switch location		At right hand door pillar on all Master Deluxe except Coupes. On lamp on all Master and Coupes
Fuse	Type, volts & amps.	#3A-6 volts-20 amps.	
	Location	On back of ammeter	
Light switch make	Delco-Remy		
Horn	Make and type		Delco-Remy, vibrator
	Tone adjustment		Screw type
	Location		Left side of cylinder head

10-15-37, 1-21-38 - Taxicab & School Bus added.

## BATTERY AND LIGHTS



## INSTRUMENTS

INSTRUMENTS MAKE: AC \*\*\* TYPE: Electric, except speedometer which is driven by flexible shaft.

MASTER DELUXE-ALL  
MASTER-CABRIOLET  
TAXICAB

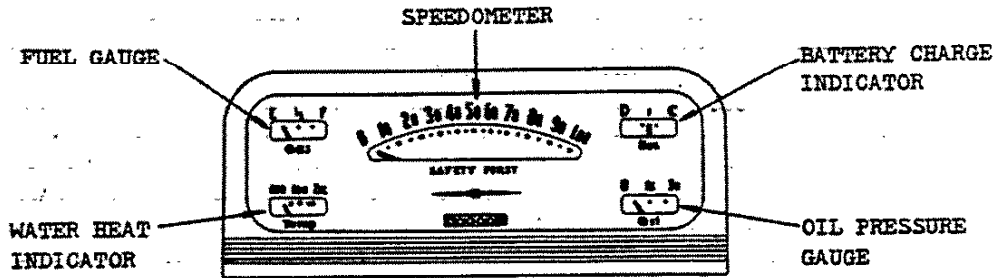

MASTER-ALL  
(Except Cabriolet)

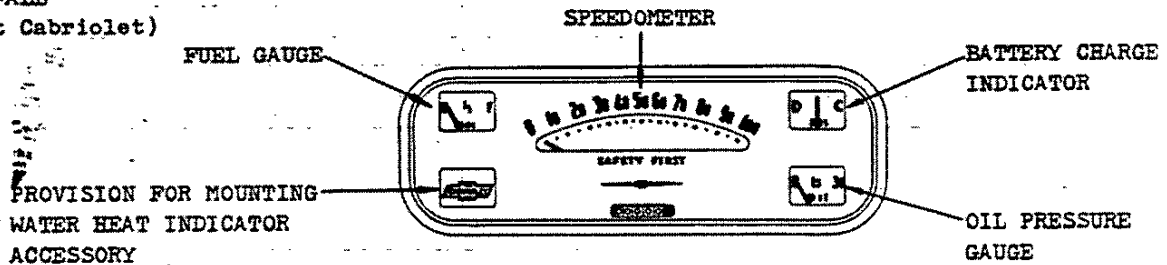

ALL TRUCKS

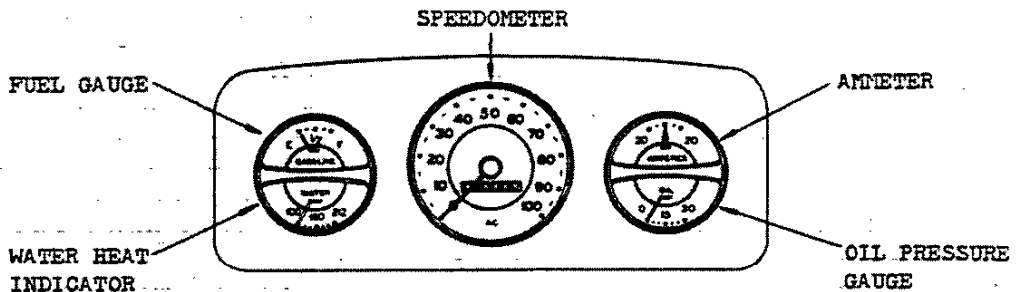

NOTE: For speedometer gear ratios see UNIVERSAL JOINTS.

## TOOLS

		PASSENGER CARS		TRUCKS			
		MAS. DELUXE & MAS.	TAXICAB	HALF TON	3/4 TON	ONE TON	1-1/2 TON & S. BUS
Jack	Type or capacity	Bumper - 1500#		2500#	2500#	3000#	3500#
	Raised height	Adjustable	15-1/16"	14-1/16"	15-1/8"	16"	15-1/2"
	Lowered height	Adjustable	6-1/2"	8-1/16"	6-1/2"	7"	9-1/2"
Starting crank and jack handle			Yes				
3-1/2" rd. shank screw driver							
Wrenches	9" adjustable		None	Yes	Yes	Yes	*Yes
	Open end						
	Spark plug	Yes					
	Wheel	Yes					
Tire iron							
6" combination pliers							
10oz. ball peen hammer			None				
Pressure lubrication gun							

\* - Also 3-1/2" round shank cross recess head screw driver for School Bus only.

10-15-37, 1-21-38 - Taxicab & School Bus added. Tire pump and oil can removed.

## INSTRUMENTS AND TOOLS

## CHASSIS LUBRICATION

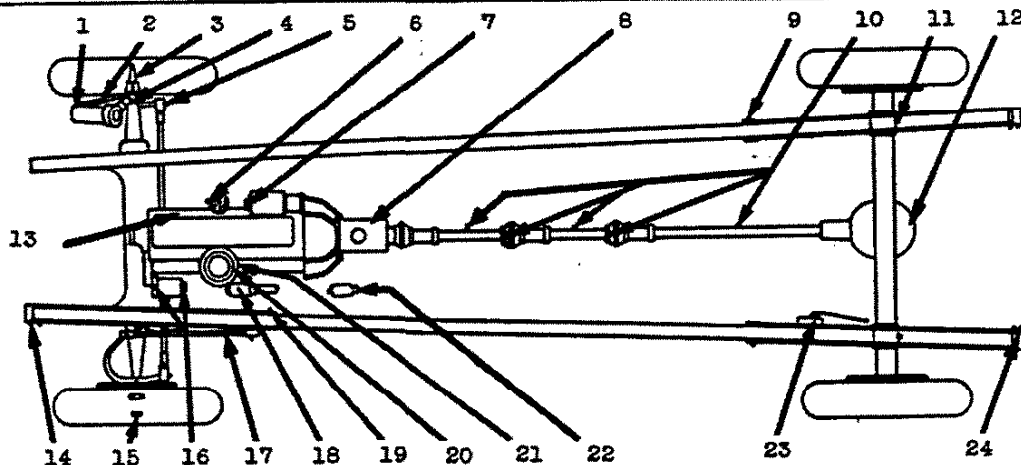

NO.	UNIT	OIL MILES	FILLERS	PASSENGER CARS			TRUCKS			
				MASTER DELUXE	MASTER TAXI		HALF TON	3/4 & ONE	1-1/2 TON & SCH. BUS	
1	Spring unit or shock abs.	1000	1 plug/side	Keep filled. GM shock insulating fluid.						None
2	Spring unit radius rod	1000	2 P.F./side	Chassis lub.			None			
3	Spr. unit spindle bushing	2000	1 plug/side	Vaseline			None			
4	Steering knuckle	2000	2 P.F./side	Use chassis lubricant						
5	Tie-rod	1000	1 P.F./side	Use chassis lubricant						
6	Distributor shaft	1000	1 grease cup	Fill and turn down cup. Soft smooth grease.						
7	Starting motor	1000	1 oil cup	2-3 drops light oil. Light oil on links.						
8	Transmission *Check level periodically. Drain twice/year or approx. 6000-10,000 mi.	*	1 plug	1-1/2 pints			6-1/2 pts.			
				SAE #90. For extremely low temperature SAE #40 or #90 plus 10%-20% kerosene. For 1-1/2 Ton in summer at heavy service #140 or #160 may be used.						
9	Rear spring bolts	1000	1 P.F./side	None - rubber bushed			Use chassis lubricant			
10	Unlv. joints & shafts	1000	1-4 P.F.	None			@	None	Use trans. lub.	
11	Rear spring seat	1000	1 P.F./side	None-rubber bushed			Use chassis lubricant			
12	Rear axle differential		1 plug	3 pints		4-1/2 pints		9 pints		
				SAE #90 hypoid gear lubricant. For extremely low temp. use SAE #80 or 2/3 SAE #90 plus 1/3 #10W eng. oil		Use trans. lub.		See pass. cars trans. lub.		
13	Engine ** 2000-3000	**		See ENGINE lubrication - page #45						
14	Front spring shackles	1000	2 P.F./side	None			Use chassis lubricant			
15	Front wheel bearings	1000	Remove wheel	Clean and repack with high melting point grease						
16	Generator	1000	2 oil cup	2-3 drops of light oil						
17	Steering connecting rod	1000	1 P.F./end	Use chassis lubricant						
18	Steering gear	1000	1 plug	Use steering gear lubricant						
19	Front spring bolt	1000	1 P.F./side	None			Use chassis lubricant			
20	Air cleaner - Regular	2000		Remove and clean with gasoline. Dip screen in engine oil. Keep felt pad dry.						
	Air cleaner - Oil bath *** Maintain oil level	***		Remove and clean with gasoline. Dry thoroughly. Fill with oil of not less than SAE #50 viscosity.						
21	Accelerator pump shaft	5000	1 screw hole	Remove cover. Fill hole with graphite grease						
22	Brake main cylinder		1 plug	Keep filled with GM hyd. brake fluid - See BRAKES p-35						
23	Rear shock absorbers		1 plug/side	Keep filled with GM shock insulating fluid			None			
24	Rear spring shackles	1000	2 P.F./side	Use chassis lubricant						

@ - Use transmission lubricant. P.F. - Pressure fittings.

10-15-37, 1-21-38 - Water pump removed. Taxicab and School Bus added.

## CHASSIS LUBRICATION

## SPLINES

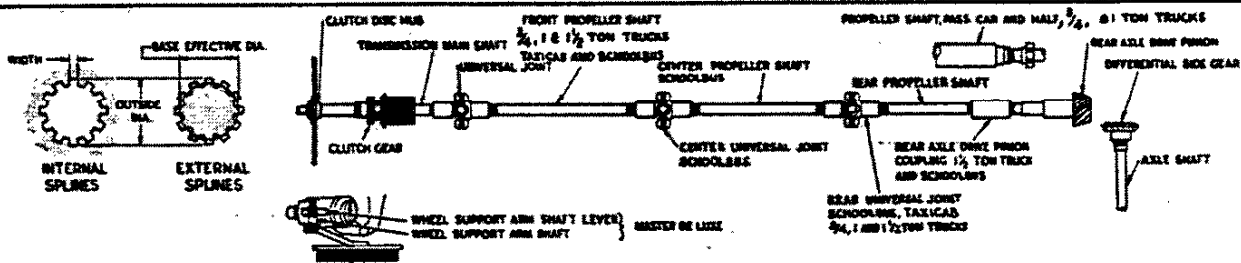

UNIT		INTERNAL	EXTERNAL	INTERNAL	EXTERNAL
Clutch disc hub and transmission clutch gear shaft	10 Splines	DMAS, MAS, TAXI, 1/2, 3/4 & 1 TON		1-1/2 TON & SCHOOL BUS	
	Width	.174 - .176	.1705 - .1725	.174 - .176	.1705 - .1735
	Inside dia.	.920 - .925	.918 max.	.920 - .925	.918 max.
	Outside dia.	1.134 - 1.144	1.110 - 1.121	1.134 - 1.144	1.110 - 1.121
Transmission mainshaft and front U joint front yoke	10 Splines	DMAS, MAS, TAXI, 1/2, 3/4 & 1 TON		1-1/2 TON & SCHOOL BUS	
	Width	.152 - .154	.151 - .152	.214 - .215	.2120 - .2135
	Inside dia.	.849 - .857	.844 max.	1.184 - 1.186	1.177 max.
	Outside dia.	.985 - .993	.960 - .970	1.380 - 1.388	1.355 - 1.365
Front propeller shaft front end and front U joint rear yoke	10 Splines	DMAS, MAS, TAXI & 1/2 TON		3/4, 1, 1-1/2 TON & SCHOOL BUS	
	Width	.180 - .162	.156 - .159	.1990 - .2015	.196 - .198
	Inside dia.	.907 - .915	.847 - .863	1.1145 - 1.1195	1.0515 - 1.0605
	Outside dia.	1.057 - 1.065	1.030 - 1.032	1.306 - 1.321	1.283 - 1.284
Front propeller shaft rear end and center U joint front yoke	10 Splines	TAXICAB		3/4, 1, 1-1/2 TON & SCHOOL BUS	
	Width	.152 - .154	.151 - .152	.214 - .215	.2120 - .2135
	Inside dia.	.849 - .857	.844 max.	1.184 - 1.186	1.177 max.
	Outside dia.	.985 - .993	.960 - .970	1.380 - 1.388	1.355 - 1.363
Center and rear prop. shaft front end and center U joint rear yoke	10 Splines	TAXI, 3/4 & 1 TON		1-1/2 TON & SCHOOL BUS	
	Width	.160 - .162	.156 - .159	.1990 - .2015	.196 - .198
	Inside dia.	.907 - .915	.847 - .863	1.1145 - 1.1195	1.0515 - 1.0605
	Outside dia.	1.057 - 1.065	1.030 - 1.032	1.306 - 1.321	1.283 - 1.284
Center propeller shaft rear end and rear U joint front yoke	10 Splines			SCHOOL BUS	
	Width	- - -	- - -	.214 - .215	.2120 - .2135
	Inside dia.	- - -	- - -	1.184 - 1.186	1.177 max.
	Outside dia.	- - -	- - -	1.380 - 1.388	1.355 - 1.365
Rear propeller shaft front end and rear U-joint rear yoke	10 Splines			SCHOOL BUS	
	Width	- - -	- - -	.1990 - .2015	.196 - .198
	Inside dia.	- - -	- - -	1.1145 - 1.1195	1.0515 - 1.0605
	Outside dia.	- - -	- - -	1.306 - 1.321	1.283 - 1.284
Prop. shaft rear end coupling and rear axle drive pinion shaft	10 Splines	DMAS, MAS, TAXI, 1/2, 3/4 & 1 TON		1-1/2 TON & SCHOOL BUS	
	Width	.1605 - .1615	.1585 - .1605	.1995 - .2005	.201 - .2035
	Inside dia.	.907 - .915	.847 - .863	1.1115 - 1.1195	1.0535 - 1.0625
	Outside dia.	1.057 - 1.065	1.027 - 1.035	1.306 - 1.321	1.280 - 1.282*
Diff. side gear and axle shaft	10 Splines	DMAS, MAS, TAXI, 1/2, 3/4 & 1 TON		1-1/2 TON & SCHOOL BUS	
	Width	.180 - .183	.170 - .180	- - -	- - -
	Inside dia.	1.039 - 1.044	1.004 - 1.014	- - -	- - -
	Outside dia.	1.186 - 1.193	1.1525 - 1.1675	- - -	- - -
Diff. side gear and axle shaft	10 Splines	TAXI, 1/2, 3/4 & 1 TON		1-1/2 TON & SCHOOL BUS	
	Width	.189 - .192	.187 - .189	.259 - .262	.257 - .259
	Inside dia.	1.095 - 1.100	1.060 - 1.070	1.472 - 1.477	1.440 - 1.450
	Outside dia.	1.2555 - 1.2625	1.222 - 1.227	1.6735 - 1.6785	1.6345 - 1.6445
Wheel support arm shaft lever and shaft	16 Splines	DELUXE MASTER			
	Width	.133 - .134	.133 - .134	- - -	- - -
	Inside dia.	1.249 - 1.251	1.245 max.	- - -	- - -
	Outside dia.	1.3815 - 1.3865	1.3575 - 1.3625	- - -	- - -

\* - Propeller shaft spline dimensions are the same except O.D. which is 1.278-1.284.  
10-15-37, 1-21-38 - Data retabulated. Taxicab & School Bus added.

# CHEVROLET 1938 SPECIFICATIONS

58

BEARINGS													
ITEM	PART #	TYPE	INSIDE DIA.	OUTSIDE DIA.	WIDTH	A	B	C	D	E	F	G	
FRONT WHEEL	Inner	N.D. 909002	Cup-Cone	1.1899-1.1904	2.9625-2.9635	1.135 - 1.155	2	2	2	2	2	0	0
		N.D. 909026	Cup-Cone	1.4060-1.4065	3.1491-3.1501	1.216 - 1.236	0	0	0	0	0	2	0
		Hy. 17241	Bar'l.R.	1.5625-1.5630	3.1250-3.1256	1.230	0	0	0	0	0	0	2
	Outer	N.D. 909001	Cup-Cone	.7498 - .7503	2.0794-2.0805	.698 - .718	2	2	2	2	2	0	0
		N.D. 909025	Cup-Cone	.8435 - .8440	2.2495-2.2505	.780 - .800	0	0	0	0	0	2	0
		Hy. 17238	Bar'l.R.	.9370 - .9375	2.3437-2.3443	.800	0	0	0	0	0	0	2
	Arm Shaft	Chev.373467	Short R.	49 rollers	.0938	.955 - .975	2	0	0	0	0	0	0
		Chev.377368	Long R.	42 rollers	.0938	1.167 - 1.187	2	0	0	0	0	0	0
		Chev.373467	Short R.	32 rollers	.0938	.955 - .975	2	0	0	0	0	0	0
KING PIN THRUST	Chev.352569	Ball	.735 - .760	1-9/16	9/16	0	2	2	2	2	0	0	
	Chev.373476	Ball	.868 - .893	1-5/8	9/16	2	0	0	0	0	0	0	
	Chev.365309	Ball	.9225 - .9475	1-23/32	5/8	0	0	0	0	0	2	0	
	Chev.121461	Roller	1.135	2.1875	5/8	0	0	0	0	0	0	2	
STEERING GEAR	Worm	Chev.261866	Taper R.		1.750 - 1.7505	.373 - .377	2	2	2	2	2	2	
		Chev.262605	Ball	.4370 - .4375		1.030 - 1.034	1	0	0	0	0	0	
	Roller	Chev.264340	Roller	21 rollers	.077	.940 - .955	0	1	1	0	0	0	
GENERATOR	N.D. 903203	Ball	.6689 - .6693	1.5743-1.5748	.4724	1	1	1	1	1	1	1	
WATER PUMP	Chev.598311	D.R.Ball	.6262-.6267*	1.1806-1.1811	1-21/32	1	1	1	1	1	1	1	
CLUTCH	Release	Chev.598088	Ball	1.691 - 1.692	2-13/16	.6775 - .6975	1	1	1	1	1	1	
	Pilot	N.D. 907109	Ball	.5901 - .5906	1.3774-1.3780	.349 - .354	1	1	1	1	1	1	
TRANS-MISSION	Clutch Gear	N.D. 954141	Ball	1.3775-1.3780	2.8340-2.8346	.6643 - .6693	1	1	1	1	1	0	0
		N.D. 903209	Ball	1.7712-1.7717	3.3457-3.3465	.7430 - .7480	0	0	0	0	0	1	1
	Fr. Main Shaft	Hy. 141854	Roller	12 rollers	.1870 - .1875		0	0	0	0	0	1	1
		Hy. 590752	Roller	14 rollers	.1873 - .1875	.512 - .527	1	1	1	1	1	0	0
	Rr. Main Shaft	N.D. 954168	Ball	.9839 - .9843	2.4403-2.4409	.6643 - .6693	1	1	1	1	1	0	0
		N.D. 903307	Ball	1.3775-1.3780	3.1490-3.1496	.8218 - .8268	0	0	0	0	0	1	1
	Fr.Center Shaft	Hy. 142260	Roller	1.4989-1.4994	2.4409-2.4415	.6249 - .6299	0	0	0	0	0	1	1
Rr.Center Shaft	Hy. 121856	Roller	1.7318-1.7323	2.8346-2.8352	.6643 - .6693	0	0	0	0	0	1	1	
PROPELLER SHAFT	N.D. 903207	Ball	1.3775-1.3780	2.8340-2.8346	.6643 - .6693	0	0	0	0	1	1	2	
	N.D. 908507	Ball	1.3775-1.3780	2.8340-2.8346	.824 - .827	0	0	1	0	0	0	0	
REAR AXLE	Pinion Front	N.D. 905306	D.R.Ball	1.1807-1.1811	2.8340-2.8346	1.1825-1.1875	1	1	0	0	0	0	0
		N.D. 905206	D.R.Ball	1.1807-1.1811	2.4403-2.4409	.9345 - .9375	0	0	1	1	1	0	0
		N.D. 905309	D.R.Ball	1.7712-1.7717	3.9362-3.9370	1.5595-1.5625	0	0	0	0	0	1	1
	Pinion Rear	Hy. 125630	Roller	1.8287-1.8291	3.1246-3.1250	.743 - .748	1	1	1	1	1	0	0
		N.D. 901305	Ball	.9839 - .9843	2.4403-2.4409	.6643 - .6693	0	0	0	0	0	1	1
	Diff. Bearing	Hy. 127861	Bar'l.R.	1.6924-1.6929	2.9523-2.9528	.659 - .679	2	2	0	0	0	0	0
		N.D. 902100	Ball	1.6924-1.6929	3.1490-3.1496	.7057 - .7117	0	0	2	2	2	0	0
		N.D. 954186	Ball	2.4403-2.4409	3.9362-3.9370	.8218 - .8268	0	0	0	0	0	2	2
	Axle Shaft	Hy. 111103	Roller	1.2949-1.2957	2.4056-2.4062	1.209 - 1.219	2	2	0	0	0	0	0
Hy. 111104		Roller	1.5302-1.5308	2.7812-2.7818	1.334 - 1.344	0	0	2	2	2	0	0	
REAR WHEEL	Inner	Hy. 144527	Bar'l.R.	2.6250-2.6255	4.4680-4.4688	.970 - .975	0	0	0	0	0	2	2
	Outer	Hy. 144525	Bar'l.R.	2.2500-2.2505	3.8750-3.8758	.895 - .900	0	0	0	0	0	2	2
TOTAL NUMBER OF ANTI-FRICTION BEARINGS PER VEHICLE						28	22	23	21	22	26	27	

A = MASTER DELUXE    B = MASTER    C = TAXICAB    D = HALF TON    E = 3/4 & ONE TON    F = 1-1/2 TON  
 G = SCHOOL BUS        R = ROLLER    D.R. = DOUBLE ROW        \* - Outside diameter of shaft

10-15-37, 1-21-38 - Taxicab, School Bus, water pump bearings added.

## BEARINGS

## INDEX

A		E - Continued	
Air Cleaner .....	46	Engine-Lubrication System .....	45
Auxiliary Springs .....	31	-Mountings .....	48
Axle-Front .....	28	-Performance .....	36
-Rear .....	33	-Power and Torque .....	37, 38
		-R.P.M. Charts .....	39 - 41
		-Weights .....	36
B		Equipment Weights-Trucks .....	11, 12
Battery .....	54	Exhaust System .....	46
Bearings-Anti-Friction .....	58	Exterior Dimensions .....	13
-Camshaft .....	43		
-Clutch .....	49	F	
-Crankshaft .....	43	Fan, Engine .....	45
-Rear Axle .....	33	Firing Order .....	47
-Transmission .....	50	Flywheel .....	49
-Universal Joints .....	34	Frame .....	25, 26
-Wheel .....	27, 28, 33	Front Axle .....	28
Body Dimensions-Passenger Cars .....	14	Front Wheel Alignment .....	28
-Coupe Pickup .....	20	Front Springs .....	29
-Sedan Delivery .....	18	Fuel-Gauge .....	46
-Trucks .....	18 - 22	-Mixture .....	46
Bore .....	36	-Pump .....	46
Brake Fluid .....	35	-Tanks .....	46
Brakes .....	35	Fuse .....	54
C		G	
Cab Dimensions .....	17	Generator .....	47
Camshaft .....	43	Glove Compartment .....	15
Carburetor .....	46	Gross Allowable Weights .....	11, 12
Canopy Express Dimensions .....	19		
Carryall Suburban Dimensions .....	19	H	
Chassis Dimensions-Passenger Cars .....	13	Headlamps .....	54
-Trucks .....	23	Horn .....	54
Chassis Lubrication .....	56	Horsepower .....	37, 38
Clutch .....	49		
Compression Ratio .....	36	I	
Connecting Rod .....	42	Ignition .....	47, 48
Cooling System .....	45	Instruments .....	55
Coupe Pickup Dimensions .....	20		
Cowl Dimensions .....	24	K	
Crankshaft .....	43	Knee Action .....	27
Cylinder Head .....	44		
		L	
D		Lights .....	54
Dome Light .....	54	Lubrication Chart .....	56
		Luggage Space Dimensions .....	15, 16
E			
Engine-Cooling System .....	45		
-Electrical System .....	47, 48		

## INDEX—Continued

M		T	
Model Symbols .....	4	Tail and Stop Lamp .....	54
Muffler .....	46	Tail Pipe .....	46
O		Tappets .....	44
Octane Selector .....	46	Thermostat .....	45
Oil-Cleaner .....	45	Tires .....	52, 53
-Pump .....	45	Tools .....	55
-Specifications .....	56	Torque .....	37, 38
P		Transmission .....	50
Parking Light .....	54	Trunk Dimensions .....	15
Panel Body Dimensions .....	18	Turning Diameter .....	51
Pickup Body Dimensions .....	20	Type Symbols—Passenger Cars .....	5
Piston .....	42	-Trucks .....	6-8
Pitman Arm .....	51	U	
Power Take-off .....	50	Universal Joints .....	34
Propeller Shaft .....	34	V	
R		Valves .....	44
Radiator-Core .....	45	Valve Timing .....	47
-Hose .....	45	W	
Rear Axle .....	33	Water-Capacity .....	45
Rear Springs .....	31	-Pump .....	45
Rocker Arms .....	44	-Thermostat .....	45
S		Weights—Passenger Car .....	10
Seat Dimensions—Passenger Cars .....	14	-Trucks .....	11, 12
-Trucks .....	17	-Gross Allowable .....	11, 12
Sedan Delivery Dimensions .....	18	Wheels .....	52
Speedometer Gear Ratios .....	34	Wheel Alignment .....	28
Serial Numbers .....	9		
Shackles .....	30-32		
Shock Absorbers .....	32		
Spark Advance .....	47		
Spark Plug .....	48		
Splines .....	57		
Springs .....	29-32		
Stake Body Dimensions .....	21		
Stake Express Body Dimensions .....	22		
Steering-Gear .....	51		
-Wheel .....	51		
Stock Rack Body Dimensions .....	22		
Stroke .....	36		
Symbols—Model .....	4		
-Type .....	5-8		

[The page contains extremely faint and illegible text, likely bleed-through from the reverse side of the document. The text is scattered across the page and does not form any recognizable words or sentences.]

**Automobile Manufacturers Association**  
**\* Consolidated Specification Questionnaire**  
**For 1938 Models**  
**Mechanical Details**

Make of Car Chevrolet Model Master Deluxe & Master Pass. Cars.  
 Name of Maker Chevrolet-Division of General Motors Corporation Address Detroit, Michigan  
 Date September 20, 1937

**NOTE—Only standard equipment included in Factory Delivered price should be included in this questionnaire**

**ENGINE**

No. of cylinders ..... 6  
 Valve arrangement ..... In head  
 Bore ..... 3-1/2" Stroke ..... 3-3/4"  
 Engine mounted on springs, bolts through rubber or vulcanized rubber and no bolts ..... Rubber  
 Rubber mountings—Used at front, rear, or both ..... Both  
 Number of ..... 5  
 Engine—make and model ..... Chevrolet 1938  
 Cylinder arrangement (angle of Vee in degrees) ..... Cast in line  
 Cylinder head, cast iron or aluminum ..... Cast Iron  
 Piston displacement ..... 216.5 cu. in.  
 Taxable horsepower ..... 29.4  
 Maximum brake horsepower at R.P.M. ..... 85 @ 3200  
 Maximum torque (ft.-lbs.) at R.P.M. ..... 170 @ 900 to 2000  
 R.P.M. with standard rear axle and tires ..... 3145 Master Deluxe  
 Compression Ratio—  
 Standard ..... 6.25-1  
 Standard compression pressure—pounds—  
 At what R.P.M. ....  
 At cranking speed .....

**PISTONS and RINGS**

Piston  
 Make ..... Own  
 Material ..... Cast Iron  
 Features— Dome head-Slipper skirt-Tin plated  
 Weight—ounces—without rings, pin or bushing ..... 22.7  
 Length ..... 4-11/64"  
 Clearance—  
 Top ..... .006" to ..... .0135"  
 Bottom ..... .0015" to ..... .003"  
 No. of grooves in piston ..... 3  
 Piston ring groove depth—  
 Oil ..... .173" - .183" Compression ..... .150" - .162"  
 No. of oil rings used per piston ..... 1  
 Width of oil rings ..... .1860" - .1865"  
 Width of oil ring gap ..... .005" - .015"  
 No. of compression rings used per piston ..... 2  
 Width of compression rings ..... .1235" - .1240"  
 Width of compression ring gap ..... .005" - .015"  
 Maximum wall thickness of oil rings ..... .155"  
 Maximum wall thickness of compression rings ..... .155"

**RODS and PINS**

Wristpin—  
 Length ..... 3.135" - 3.165" Diameter ..... .8645" - .8950"  
 Locked in rod, piston or floating ..... Locked in rod  
 Clearance ..... Slip fit  
 Hole finish—ream, diamond bore, broach or ground ..... D.B.  
 Connecting rod—  
 Length—center to center ..... 6-13/16"  
 Material ..... Drop forged steel  
 Weight—ounces ..... 22.3  
 Crankpin journal—  
 Diameter ..... 2-5/16" Length ..... 1-1/2"  
 Lower bearing—  
 Material ..... Babbitt  
 Make ..... Own  
 Clearance ..... .001" to ..... .0025"  
 End play ..... .0065" to ..... .0135"  
 Shim—solid, laminated or none ..... Solid  
 Spun or separate ..... Centrifugally cast  
 Rods and pistons removed from above or below ..... Above

**CRANKSHAFT**

Front flywheel used ..... No  
 Vibration dampener used—yes or no ..... Yes  
 Type ..... Oscillating  
 Crankshaft counterweights used, number of ..... 7  
 Which main bearing takes thrust ..... Rear intermediate  
 Crankshaft end play ..... .004" - .007"  
 Main bearing—  
 Material ..... Steel backed babbitt  
 Clearance ..... .002" - .004"  
 Slip-in type or integral  
 with cap & case ..... Slip in type  
 Shim—solid, laminated or none ..... Solid  
 Main bearing journal diameter x length—  
 No. 1 ..... 2-11/16" x 1-3/16"  
 No. 2 ..... 2-23/32" x 1-3/16"  
 No. 3 ..... 2-3/4" x 1-7/16"  
 No. 4 ..... 2-25/32" x 1-5/8"  
 No. 5 .....  
 No. 6 .....  
 No. 7 .....  
 No. 8 .....  
 No. 9 .....

\* - All data given in this questionnaire is based on MANUFACTURING dimensions.



Make of Car Chevrolet Model Master Deluxe & Master Date September 20, 1937  
 Passenger Cars

**CRANKSHAFT (cont'd)**

Crankshaft gear—  
 Make ..... Own  
 Material ..... Steel

**CAMSHAFT**

Camshaft gear—  
 Make ..... Various  
 Material Bakelite and Fabric composition  
 Generator gear—  
 Make ..... None-belt driven  
 Material .....  
 Timing chain—  
 Make ..... None  
 Number of links .....  
 Width .....  
 Pitch .....  
 Adjustment—none, automatic or manual .....

**VALVES**

Intake valve—  
 Make ..... Own  
 Head—  
 Material ..... Extruded steel  
 Actual overall diameter ..... 1-41/64"  
 Angle of seat ..... 30°  
 Stem—  
 Material ..... Extruded steel  
 Length (Full valve length) ..... 6-5/64"  
 Diameter ..... .3407" - .3417"  
 End style ..... Grooved for cup and cone  
 Stem to guide clearance ..... .001" to .003"  
 Lift ..... .305"  
 Spring pressure and length—  
 With valve closed ..... 1-7/8" @ 42-48#  
 With valve open ..... 1-9/16" @ 111-119#  
 Out of engine ..... 2-7/32"  
 Exhaust valve—  
 Make ..... Own  
 Head—  
 Material ..... Extruded Steel  
 Actual overall diameter ..... 1-15/32"  
 Angle of seat ..... 30°  
 Is valve seat an insert ..... No  
 Stem—  
 Material ..... Extruded steel  
 Length (Full valve length) ..... 4-13/16"  
 Diameter ..... .3397" - .3407"  
 End style ..... Grooved for cup and cone  
 Stem to guide clearance ..... .002" to .004"  
 Lift ..... .3195"  
 Spring pressure and length—  
 With valve closed ..... 1-7/8" @ 42-48#  
 With valve open ..... 1-9/16" @ 111-119#  
 Out of engine ..... 2-7/32"

**VALVES (cont'd)**

Operating tappet clearance—intake ..... .006" Hot  
 Tappet clearance for valve timing—intake ..... .006" Hot  
 Operating tappet clearance—exhaust ..... .013" Hot  
 Tappet clearance for valve timing—exhaust ..... .013" Hot  
 Is valve tappet clearance automatically adjusted ..... No  
 Valve timing—  
 Intake opens ..... 9 degrees BTC piston travel .....  
 Intake closes ..... 29 " ABC " " .....  
 Exhaust opens ..... 52 " BBC " " .....  
 Exhaust closes ..... 1 " BTC " " .....

**LUBRICATION** Pressure, pressure stream  
 Lubricating system type—pressure or splash ..... splash

Oil pressure to—  
 Main bearings—yes or no ..... Yes  
 Connecting rods—yes or no ..... Pressure stream  
 Wristpins—yes or no ..... No  
 Camshaft bearings—yes or no ..... Yes  
 Rocker arm—yes or no ..... Yes  
 Timing gear or chain lubrication—positive or splash ..... Positive  
 Oil pump type ..... Gear

Oil grade recommended—SAE viscosity  
 Summer 20, 30, 20W Winter 10W or 20W  
 (30 for high speeds) .....

Normal oil pressure—lbs. at M.P.H. .... 13.5 @ 50  
 Pressure at which relief valve opens ..... 75#  
 Capacity of oil reservoir—quarts, dry 5-1/2 refill ..... 5  
 Oil pressure gauge make ..... AC  
 Type of oil drain ..... Plug in bottom of oil pan  
 Oil reservoir gauge type ..... Rod  
 External oil filter make ..... None  
 Oil cooler make ..... None  
 Chassis lubrication—  
 Type ..... High Pressure Gun  
 Make .....  
 Capacity ..... 14 gals. (18 gals. on Business Coupes and Master Sedan Delivery)

**FUEL**

Gasoline tank—capacity .....  
 Fuel feed—  
 Type—vacuum tank, electric pump, vacuum pump or camshaft pump ..... Camshaft Pump  
 Make ..... AC Model ..... AF  
 Carburetor—  
 Make ..... Carter Model ..... W-1  
 Size ..... 1-1/4"  
 Type—  
 Up or down draft ..... Down Single or dual ..... Single  
 Supercharger—  
 Make ..... None Type .....  
 How driven .....  
 Intake manifold heat control—manual, automatic or none ..... Automatic  
 Automatic choke, make ..... None

Make of Car Chevrolet Model Master Deluxe & Master Date September 20, 1937  
Passenger Cars

**FUEL (Cont'd)**

Air cleaner—intake silencer make AC  
 Exhaust pipe diameter 1-7/8"  
 Muffler make Own

**COOLING**

Water pump—  
 Type Centrifugal  
 Drive V-Belt  
 Water circulation thermostat make Harrison  
 By-pass for recirculation—yes or no No  
 Radiator shutter—  
 Make None  
 Control—maxual or automatic  
 Radiator core—  
 Type Ribbed cellular  
 Make Harrison  
 Cooling system—capacity, quarts 14  
 Water jackets full length of cylinders—yes or no Yes  
 Lower radiator hose—  
 Inside diameter 1-1/2" Length 2-3/4" & 5"  
 Upper radiator hose—  
 Inside diameter 1-1/4" Length 5-5/8"  
 Fan belt—  
 Number used One  
 Type—flat, vee (give angle of vee) Vee-32°  
 Make Various  
 Length, outside 42-7/8" Width, maximum 11/16"  
 Fan—  
 Make Own

**IGNITION**

Ignition unit—  
 Make Delco-Remy Model 1110008  
 Manual advance, degrees None  
 Maximum automatic advance, degrees 42-50  
 Vacuum advance, degrees 17  
 Breaker gap .018" - .024"  
 Cam angle 5° BTC  
 Timing—breaker points open 5° BTC deg. or inches  
piston travel (after or before) top center with spark control  
lever in the position.  
 Timing marks on flywheel, vibration dampener or none Flywheel  
 Firing order 1-5-3-6-2-4  
 Ignition coil make Delco-Remy  
 Amperage draw of coil—  
 With engine stopped 4.8  
 With engine idling 2.5  
 Ignition switch make Delco-Remy  
 Spark plug—  
 Thread—3/8 standard, 10 m.m., 14 m.m. or 18 m.m. 14 M.M.  
 Make AC Model 46  
 Gap .040"  
 Ignition cable make Delco-Remy

**BATTERY**

Make Delco  
 Capacity—ampere hours 100 Amp. @ 20 hour rate  
 Number of plates per cell 17  
 Bench charging rate—  
 Start 6 Finish 5  
 Which battery terminal is grounded Negative

**STARTING MOTOR**

Make Delco Remy Model 1107001  
 Normal engine cranking speed 65  
 Lock test—  
 Amperage draw 525  
 Volts 3.4  
 Torque in foot pounds 14  
 No load test—  
 Amperage draw 125  
 Volts 5.4 R.P.M. 2500  
 Type of drive—Bendix, manual gear,  
overrunning clutch or chain Overrunning clutch  
 Automatic starting device—  
 Make None  
 Type None  
 Starting motor pinion meshes front or rear Front  
 No. of teeth in flywheel 159  
 Face width of flywheel teeth 1/2"  
 Flywheel teeth integral or steel ring Steel ring  
 Gear ratio between starter armature and flywheel 15.44

**GENERATOR**

Make Delco-Remy Model 1100004  
 Driven by V-Belt  
 How ventilated Suction fan  
 Field fuse capacity None  
 Type—third brush, shunt, etc. Fixed third brush  
 Current regulator, voltage regulator or current and  
 voltage control unit Voltage regulator  
 Cutout relay—  
 Voltage at closing 6.5 - 7.0  
 Armature speed at closing 800  
 Car speed at closing 8-9 MPH  
 Amperes to open 0-3.0  
 Maximum charging rate cold—  
 Temperature 70° F.  
 Amperes 26-30  
 Voltage 8  
 R.P.M. 3400  
 Maximum charging rate hot—  
 Temperature 120° F.  
 Amperes 25-28  
 Voltage 8  
 R.P.M. 3500  
 Car speed for maximum charging rate 27.5 MPH Deluxe  
 Ammeter make AC 30.6 MPH Master

Make of Car Chevrolet Model Master Deluxe & Master Date September 20, 1937  
Passenger Cars

**LAMPS**

Lighting switch make Delco-Remy  
Are tail and dash lights in series No  
Headlight—  
Make Guide  
Beam indicator None  
Parking light make Guide (in headlamp)  
Tail and stop light make Guide  
Becking light make None  
Horn—  
Type—vibrator or motor Vibrator  
Make Delco-Remy  
No. used One  
Amperage draw of each 10

**CLUTCH**

Make Own-Diaphragm spring type  
Centrifugal or semi-centrifugal Neither  
How ventilated By holes in clutch cover  
Power operated unit—make None  
Vibration insulation or neutralizer—fabric,  
rubber blocks or springs Springs  
No. of clutch driving discs One  
No. of clutch driven discs One  
Clutch facing—  
Material—woven or moulded asbestos Asbestos comp.  
Inside diameter 8-1/4"  
Outside diameter 9"  
Thickness 1/8"  
No. required Two

**TRANSMISSION**

Transmission—  
Make Own  
No. of forward speeds 3  
Automatic or auxiliary shifting mechanism—  
Make None  
Type—centrifugal, vacuum, electric or hydraulic  
Automatic overdrive—  
Make None  
Oil capacity—pints  
Grade recommended—S.A.E. viscosity  
Summer Winter  
Gear ratio in high—standard 5-passenger  
4-door sedan See rear axle  
Transmission ratio—  
In overdrive None In second 1.68:1  
In low 2.94:1 In reverse 2.94:1  
Constant mesh gears on second Yes  
Spur or helical gears—  
For second speed Helical  
For first speed Spur  
For reverse speed Spur  
Synchronous meshing second and third gears Yes

**TRANSMISSION (Cont'd)**

Transmission oil—  
Capacity—pints 1-3/4  
Grade recommended—S.A.E. viscosity  
Summer 90 Winter 90 or 90 + 10%  
Universal joints— kerosene below zero  
Make Own  
Number used One  
Type—fabric, rubber, metal with anti-friction  
bearing or metal with plain bearing Metal plain brg  
Lubricated Self from transmission  
Drive taken through springs, torque arm, torque tube or  
radius rods Springs  
Torque taken through springs, torque arm, torque  
tube or radius rods Torque tube

**REAR AXLE**

Rear axle—  
Make Own  
Type—semi, full or three-quarter floating Semi-floating  
Minimum road clearance under center of rear  
axle—tires inflated 8-1/2"  
Rear axle oil—  
Capacity—pints 3  
Grade and type recommended— Extreme pressure  
lubricant both summer and winter.  
Type of bearing—spiral bevel, worm, hypoid Hypoid  
Gear ratio—standard 5-passenger 4-door sedan 4.222 Mas.  
Deluxe, 3.727 Master  
Number of teeth—38 Deluxe 9 Deluxe  
41 Master In pinion 11 Master  
How is pinion adjusted— Shims and tapered collar  
How is pinion bearing adjusted—screw or shims Fixed type  
Are pinion bearings in sleeve No  
Backlash between pinion and ring gear .005" to .007"  
Are pinion bearings preloaded No

**TIRES and WHEELS**

Tires—  
Make Various  
Size 6.00-16 No. of plies 4  
Inflation pressure—Front 25# Rear 28#  
Axle clearance for jack—tires inflated  
Front Rear  
Wheels—  
Type Short spoke disc wheels  
Make Own  
Rim—Diameter 16" Width 4"

**SPRINGS**

Front spring—  
Independent or conventional suspension Ind.-Deluxe  
If conventional, are special radius rods Con.-Master  
or sway eliminators employed No

Make of Car Chevrolet Model Master Deluxe & Master Date September 20, 1937  
 Passenger Cars © - Revised 10-20-37

**SPRINGS (Cont'd)** Coil-Deluxe

Type—coil, semi-elliptic or transverse S. E. - Master  
 Make Own  
 Material Chrome Carbon Spring Steel  
 If leaf—Master  
 Length 36" Width 1-3/4"  
 Number of leaves—5-passenger, 4-door sedan 9  
 If coil—Master Deluxe  
 Free length 9-11/16" Inside diameter 2-7/32"  
 Diameter of wire .692" - .694"  
 Rate for above 1520 pounds per inch  
 Shackled front or rear Front—Master  
 Anti-shock shackle location None  
 Rear spring—  
 Independent or conventional suspension Conventional  
 Type—coil, semi-elliptic or transverse Semi-elliptic  
 Make Own  
 Material Chrome Carbon Spring Steel  
 If leaf—  
 Length 49" Width 1-3/4"  
 Number of leaves—5-passenger, 4-door sedan 8

Rate for above 129 pounds per inch  
 Spring leaves lubricated with Graphite grease  
 Spring cover make Various—Master Deluxe Rear  
 Spring shackles—  
 Front—Type Threaded Make Own—Master  
 Rear—Type Threaded Make Own  
 Spring bolts— Threaded—Master Front  
 Type Rubber bushed—Rear  
 Shock absorbers—  
 Make Delco-Remy  
 Type—one way, two way or direct-acting TWO WAY  
 Master Deluxe front, one way—  
 Master front and all rear

**STEERING**

Steering gear—  
 Type Worm and roller  
 Make Own  
 Ratio 17-1/2:1 Deluxe, 19:1 Master  
 Type of linkage—double tie-rod, single tie-rod,  
 cross or conventional Conventional  
 Car turning radius—feet—right, left or both 19-1/4'R, 20'L  
 \*Caster—degrees 1-3/4 to 2-3/4  
 \*Camber—degrees 1/2 to 1-1/2 inches to  
 \*Toe-in—inches 5/64 to 1/8  
 Crosswise inclination of kingpin—degrees 7° - 10' ± 1°  
 Steering wheel—  
 Make Own  
 Diameter 17-5/16"  
 \* - Service dimensions Master only -  
 Special alignment fixtures for  
 Master Deluxe.

**STEERING (Cont'd)**

Front axle—  
 Make Own  
 Section type—I-beam or tubular I-beam Master \*\*  
 End type—Elliott or reverse Elliott R. E. Master \*\*  
 Minimum road clearance—tires inflated 10-3/8" Deluxe  
 8-5/8" Master

**BRAKES**

Foot brakes—  
 Make Own  
 Type of mechanism, hydraulic or mechanical Hydraulic  
 If vacuum booster is standard, state make None  
 Brake lining moulded, semi-moulded or woven Moulded—Deluxe  
 Drum— Semi—Master  
 Material C. I. rim, Diameter 11"  
 Lining— steel web  
 Length per wheel 22-5/8"  
 Width 1-3/4" Thickness 3/16"  
 Clearance—Adjust to slight rag. Back  
 of 4 notches. 158-1/4 sq. in.  
 Total foot braking area  
 Percent braking power on rear wheels 47-1/2  
 Hand brake location Lever mounted on frame  
 Hand lever operates on—transmission, separate  
 rear brakes, rear service brakes or all  
 four service brakes Rear service brakes  
 Hand brake—  
 Internal or external Internal  
 Drum diameter 11"  
 Lining—  
 Length per drum 22-5/8"  
 Width 1-3/4" Thickness 3/16"  
 Clearance Same as service brakes

**FRAME**

Frame—  
 Make Own  
 Type Box-girder  
 Depth—maximum 4-31/64"  
 Thickness—maximum 3/32" (5/32" flanges)  
 Flange width—maximum 2-1/4" Box (3-7/8" Flanges)  
 Wheelbase 112-1/4" @  
 Tread—  
 Front 57-1/4" -Deluxe, 56-3/8" Master  
 Rear 59"  
 Weight of standard 5-passenger, four-door sedan—  
 Shipping 2935# Deluxe, 2845# Master  
 Per cent on front axle 50  
 Curb 3055# Deluxe, 2965# Master  
 Price of standard 5-passenger, 4-door sedan  
 First serial number, this series HA 1001-Del. HL 1001 Mas.  
 Serial number location On plate under hood on  
 right side of cowl  
 Overall length of car—  
 Without bumpers OR spare tire 171-3/4"  
 With bumpers 187-5/16" Deluxe  
 187-1/16" Master

\*\* - DELUXE - King pin support with Elliott type ends.

Make of Car Chevrolet Model Master Deluxe & Master Date September 20, 1937

Passenger Cars

NOTE—In giving bearing dimensions, kindly use the following order: inside diameter, outside diameter and width. Where cup and cone bearings are used, give both cup and cone numbers.

BEARINGS

Starting motor commutator end bearing—		Rear axle pinion or worm shaft front bearing—	
Make or type .....	Bears in housing end	Make or type .....	New Departure
Size or number .....	1/2" I.D. x 15/16" Long	Size or number .....	5306
Starting motor drive end bearing—		Rear axle pinion or worm shaft rear bearing—	
Make or type .....	None	Make or type .....	Hyatt
Size or number .....		Size or number .....	C-1506
Starting motor outboard bearing—		Differential right bearing—	
Make or type .....	Rolled Bronze Bushing	Make or type .....	Hyatt
Size or number .....	1/2" x 9/16" x 25/32"	Size or number .....	KA-11360-Z
Generator commutator end bearing—		Differential left bearing—	
Make or type .....	Bronze Bushing	Make or type .....	Hyatt
Size or number .....	35/64" x 25/32" x 51/64"	Size or number .....	KA-11360-Z
Generator drive end bearing—		Rear wheel inner bearing—	
Make or type .....	New Departure	Make or type .....	None
Size or number .....	3203	Size or number .....	
Super-charger—		Rear wheel outer bearing—	
Make or type .....	None	Make or type .....	Hyatt
Size or number .....		Size or number .....	111103
Clutch throwout bearing—		Front wheel inner bearing—	
Make or type .....	Various-Thrust Ball Bearing	Make or type .....	New Departure
Size or number .....	1-11/16" I.D. x 11/16" wide	Size or number .....	9002
Clutch pilot bearing—		Front wheel outer bearing—	
Make or type .....	New Departure	Make or type .....	New Departure
Size or number .....	7109	Size or number .....	9001
Transmission pocket or spigot bearing—		Kingpin upper bearing—	
Make or type .....	Rollers	Make or type .....	Bronze Bushing
Size or number .....	3/16" x 33/64" (14 req'd.)	Size or number .....	(Del. 7/8" x 1-3/64" x 1-5/16") (Mas. 47/64" x 59/64" x 1-17/64")
Transmission reverse idler bearing—		Kingpin lower bearing—	
Make or type .....	Rolled Bronze Bushing	Make or type .....	Bronze Bushing
Size or number .....	3/4" x 7/8" x 3/4" (2 req'd.)	Size or number .....	(Del. 7/8" x 1-3/64" x 1-5/16") (Mas. 47/64" x 59/64" x 1-17/64")
Transmission main shaft front bearing—		Kingpin thrust bearing—	
Make or type .....	New Departure	Make or type .....	New Departure-Special
Size or number .....	954141	Size or number .....	(Deluxe 7/8" x 9/16") (Master 3/4" x 9/16")
Transmission main shaft rear bearing—		Front spring— Master only.	
Make or type .....	New Departure	Bolt—	
Size or number .....	954168	Bushing size .....	11/16" I.D.
Transmission countershaft front bearing—		Bushing type .....	Threaded Bushing
Make or type .....	Rolled Bronze Bushing	Shackles—	
Size or number .....	7/8" x 1" x 1-1/4"	Upper end .....	21/32" - 11 Thds.
Transmission countershaft rear bearing—		Lower end .....	21/32" - 11 Thds.
Make or type .....	Rolled Bronze Bushing	Rear spring—	
Size or number .....	7/8" x 1" x 1-1/4"	Bolt—	
Free wheel unit rear bearing—		Bushing size .....	1/2" I.D.
Make or type .....	None	Bushing type .....	Rubber
Size or number .....		Shackles—	
Free wheel unit front bearing—		Upper end .....	21/32" - 11 Thds.
Make or type .....	None	Lower end .....	21/32" - 11 Thds.
Size or number .....			

Sheet No. 1 - Body Equipment

AUTOMOBILE MANUFACTURERS A  
BODY DETAIL AND EQUIPMENT FORMS

DIRECTIONS

Only standard equipment included in the Factory Delivered price shown in column 3 should be listed on this sheet. Please arrange body types in an ascending price scale with the lowest priced type at the top and the highest priced type at the bottom.

IMPORTANT - To save your time, where an item is common to several types, use arrows to indicate the fact as shown in diagrams.

Standard abbreviations may be used where space limitations make this necessary. Where sub-headings such as those shown in column for Gasoline Gauge Type are identified with numerals, these numerals may be used in filling in form.



MAKE OF CAR Chevrolet  
 NAME OF MAKER Chevrolet -  
 Division of General Motors Corporation  
 ADDRESS Detroit, Michigan  
 DATE September 20, 1937

MAKE AND MODEL	BODY TYPE List Types on Ascending Price Scale Beginning with the Lowest Price	Factory Delivered Price Including Federal Tax and Handling Charge	Number of Pass- eng- ers	Wheel- base	Shipping Weight	Seating Arrang- ment Number See Dir. gram	No. of Doors	Gear Ratio	Standard Com- pression Ratio	Tire Size	Speed- ometer Make	GASOLINE GAUGE			Thermo- meter Make
												TYPE 1 Mech- ical 2 Elec- 3 Hydro- static	Make	Make	
Chevrolet Master Deluxe	Coupe Coach Sport Coupe Sedan Town Sedan Sport Sedan		2 5 2-4 5 5 5	112 1/4	2840 2910 2870 2935 2935 2960	1 3 2 4 3 4	2 2 2 4 2 4	4, 22 ↓ ↓ ↓ ↓ ↓	6, 25 ↓ ↓ ↓ ↓ ↓	@ ↓ ↓ ↓ ↓ ↓	AC ↓ ↓ ↓ ↓ ↓	AC ↓ ↓ ↓ ↓ ↓	2 ↓ ↓ ↓ ↓ ↓	AC ↓ ↓ ↓ ↓ ↓	
Chevrolet-Master	Coupe Coach Sedan Town Sedan Cabriolet Sport Sedan Sedan Delivery Coupe Pick-Up		2 5 5 5 4 5 - 2		2770 2800 2845 2830 2790 2885 2810 2935	1 3 4 3 2 4 - 1	2 2 4 2 2 4 3 2	3, 73 ↓ ↓ ↓ ↓ ↓ ↓ ↓							



Sheet No. 2—Body Details

BODY DIM

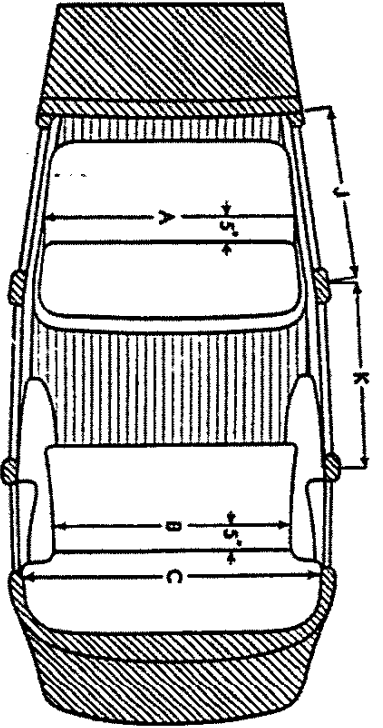

- A Width of front seat cushion, measured 5 inches from back.
- B Width of rear seat cushion, measured 5 inches from back.
- C Shoulder room, rear
- D Distance from back of front seat to front of rear cushion with front seat in its extreme forward position
- E Depth of front seat cushion
- F Depth of rear seat cushion
- G Distance from dash to front of front cushion with seat in its extreme forward position
- H Amount of front seat adjustment
- I Width of front door, at belt
- J Width of front door, at belt

MAKE AND MODEL	BODY TYPE List Types on Ascending Price Scale Same as Sheet No. 1	Body Make	BODY MATERIAL			TOP FRAME TYPE 1 Wire Mesh 2 Laminated 3 Steel	Lacquer Make	Hardware Make	Width of Left Front Pillar on Diagonal Approximately at Right Angle to Driver's Vision	Is Steering Column Adjust- able (Give Range in Inches)	A
			Frame Work	Panel	Rear and Quarter Section Panel						
Chevrolet	Coupe	Fisher	Steel	Steel	Steel				4-3/8	None	46
Master Deluxe	Coupe								4-3/8		46
	Sport Coupe								4-3/8		46
	Sedan								4-3/8		48
	Town Sedan								4-3/8		46
	Sport Sedan								4-3/8		48
Chevrolet-Master	Coupe								4-3/8		46
	Coach								4-3/8		21
	Sedan								4-3/8		48
	Town Sedan								4-3/8		21
	Cabriolet								4-1/4		46
	Sport Sedan								4-3/8		48
	Sedan Delivery*								4-3/8		21
	Coupe Pick-Up**								4-3/8		46

\* - Turnstedt. \* - Load platform dimensions are:- 66" x 54" x 41-1/8".  
 \*\* - Load platform dimensions are:- 66-1/8" x 38-7/8" x 12", Tail gate height = 10".



