



GENERAL

MODEL IDENTIFICATION	2
SERIAL NUMBERS AND IDENTIFICATION	3
EXTERIOR EQUIPMENT	4
INTERIOR EQUIPMENT	5-6
EXTRA COST EQUIPMENT	7-8
GT SPORT EQUIPMENT – OPTION	9
CUSTOM INTERIOR OPTION	10
CUSTOM EXTERIOR OPTION	10
VEGA ESTATE	11
AIR CONDITIONING EQUIPMENT	12

MODEL IDENTIFICATION

BODY	SERIES NAME	BODY STYLE	MODEL DESIGNATION	PASS OR SEATS
H-CAR	VEGA	2-Dr. Notchback (Coupe)	1HV11	4
		2-Dr. Hatchback (Coupe)	1HV77	4
		2-Dr. Station Wagon	1HV15	2-Seat

SERIAL NUMBERS AND IDENTIFICATION

ONLY BASIC DESIGNATIONS SHOWN

VEHICLE SERIAL NUMBER

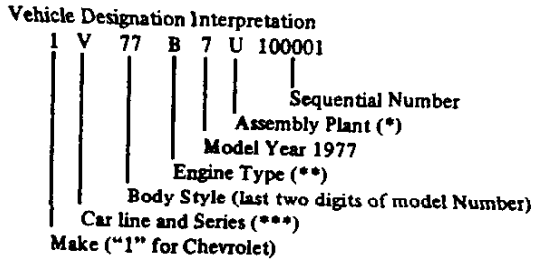

- *U - Lordstown—GMAD
- **B - L4-140 (84 H.P.)
- ***V - Vega

EXAMPLE: The twenty-fifth Chevrolet vehicle built at Chevrolet Lordstown if it were a 1HV77 model (Vega Hatchback Coupe) with a L4-140 (84 H.P.) engine would bear VIN Number 1V77B7U10025.

Location Stamped on plate attached to left hand windshield pillar.

TRANSMISSION IDENTIFICATION

Example: S7E01

Type Designation	Source Designation	Model Year	Production ^o Month & Date
ZN	R (Muncie)	1977 7	E01D*
ZN	4-Speed	L-4 engine	R - Muncie
AP	Turbo Hydra-matic	L-4 engine	D - Parma Y - Toledo
DH	5-Speed	L-4 engine	Warner Gear

Location:
4 & 5-speed Stamped on lower rear LH side of transmission below cover.
Turbo Hydra-matic Stamped on left hand side of pan.

^oMonth: E denotes May; 01 denotes 1st day.
-Alpha Characters used in identifying the Calendar Month

A - January	D - April	K - July	R - October
B - February	E - May	M - August	S - November
C - March	H - June	P - September	T - December

*-The letter "D" or "N" following the date numerals indicates day or night shift, on automatic only.

ENGINE IDENTIFICATION

Example: T1210CBL

Source Designation	Production* Month & Date	Type Designation
T (Tonawanda)	1210	CBL

140 Cubic Inch L-4, Base Engine

- CBL - Regular production engine, Turbo Hydra-matic, 2-bbl. carb.
- CBC - Regular production engine, 4-speed, 2-bbl. carb.
- CAZ - Regular production engine, 5-speed, 2-bbl. carb.

Location:
4-Cylinder engine Stamped opposite the number three cyl. on the right side of case.

*-Month: December, 12; 10th day of December, 10.

REAR AXLE IDENTIFICATION

- HM - 2.92 Axle
- EU - 3.42 Axle
- ET - 3.73 Axle

Location, Identification Number
Bottom left or right of axle tube adjacent to carrier housing.

See Power Train Section for additional information.

EXTERIOR EQUIPMENT

STANDARD EQUIPMENT EXTERIOR

EXTERIOR	1HV11	1HV77	1HV15
<u>FRONT</u>			
Bright Windshield Reveal Molding	X	X	X
Painted Louvered Radiator Grille Panel	X	X	X
Bright Radiator Grille Panel Moldings	X	X	X
Parking Lamps, Amber Lens (Except GT)	X	X	X
Bright Headlamp Bezels (Except GT)	X	X	X
Header Panel Emblem	X	X	X
Dual Exposed Windshield Wipers	X	X	X
Painted Plastic Valance Panel	X	X	X
Extruded Aluminum Bumper System	X	X	X
<u>SIDE</u>			
Front Fender Amber Marker Lamp	X	X	X
Front Door and Fixed Rear Quarter Window Bright Frame Moldings		X	X
Flush Type Front Door Handles	X	X	X
Rectangular Outside L.H. Rear View Mirror (4 x 3)	X	X	X
Hub Caps	X	X	X
Rear Quarter Panel Red Marker Lamp	X	X	X
Simulated Sail Panel Louvers	X	X	
Louvered Rear Quarter Panel			X
Fixed Rear Quarter Window with Painted Moldings	X (a)		
Bright Roof Drip Molding	X	X	X
<u>REAR</u>			
Rear End Panel Nameplate, "Vega by Chevrolet"	X	X	
Tailgate Nameplate, "Vega by Chevrolet"			X
Rear Window or Tailgate Window Reveal Moldings	X	X	X
3 Lens Tail and Back-Up Lamps - Bright Bezel	X	X	
Single Tail Lamp with Back-Up Lamp, Bright Bezels			X
Swing Up Deck Lid and Rear Window		X	X

(a) With black rubber seal

INTERIOR EQUIPMENT

STANDARD EQUIPMENT INTERIOR

INTERIOR	1HV11	1HV77	1HV15
SEATS AND FLOOR COVERING			
High Back Front Bucket Seats, Full Foam	X	X	X
Folding-Rear Seat, Foam	X (d)	X	X
Package Shelf Cover, Embossed Board	X		
Folding Front Seat Back Lock, Black	X	X	X
Folding Rear Seat Back Lock, Bright		X	X
Stowage Compartment, Painted Metal	X (f)	X	X
Rear Seat Back, Carpeted		X	X
Unpainted Aluminum Load Compartment Floor, Rubber Mat		X	
Unpainted Aluminum Load Compartment Floor, Carpet			X
Floor Covering, Carpet	X	X	X
Front Seat Belt and Shoulder Belt System	X	X	X
Rear Seat Belts	X	X	X
Front Seat Integral Head Restraints	X	X	X
Transmission Shift Lever Boot and Ring	X	X	X
Transmission Shift Mini Console, Floor Mounted w/Automatic Transmission	X	X	X
Front Seat Hinge Arm Cover	X	X	X
Parking Brake Cover, Color-Keyed	X	X	X
Parking Brake Lever, Black	X	X	X
INSTRUMENT PANEL AND STEERING WHEEL			
Instrument Cluster Color Keyed	X	X	X
Instrument Panel Knobs, Bright Beads Black Inserts, Graphic Functions	X	X	X
Heater Control Levers, Bright	X	X	X
Instrument Panel Pad, Upper	X	X	X
Clock Hole Cover	X	X	X
Ash Tray Faceplate Black	X	X	X
2-Speed Electric Windshield Wipers, and Washers	X	X	X
Vent Control Knobs, Cowl Kick Pad	X	X	X
Steering Wheel, Color-Keyed	X	X	X
Color-Keyed Steering Wheel Shroud with 'Vega' Nameplate	X	X	X
Turn Signal Knob, Black Vinyl	X	X	X
Steering Column Ignition Lock	X	X	X
Cigarette Lighter	X	X	X
Instrument Panel Cover Plate and "Vega" Nameplate (W/O A/C)	X	X (e)	X
Audio and Visual Seat-Shoulder Belt Warning System (Driver Side Only)	X	X	X
Bright Hot Stamping around Instrument Cluster and Bezel	X	X	X
Instrument Panel Compartment	X	X	X

(d) Fixed seat (reduced profile)

(e) With RPO Z29, Hand-Box replaces Cover Plate.

(f) Full trunk

INTERIOR EQUIPMENT

STANDARD EQUIPMENT INTERIOR

INTERIOR	1HV11	1HV77	1HV15
ROOF AND PILLARS			
Molded Headlining	X	X (c)	X (c)
Windshield Pillar and Garnish Moldings, Colored Plastic	X	X	X
Center Pillar Molding, Colored Plastic	X	X	
Rear Quarter Window Moldings, Colored Plastic	X	X	
Rear Window Molding, Colored Plastic	X	X	X
Roof Side Rail Garnish Moldings, Colored Plastic	X	X	X
Roof Shoulder Harness Retractor Covers, Colored Plastic	X	X	X
Sunshades, Dual Padded Vinyl	X	X	X
Coat Hooks, Colored Plastic	X	X	X
Center Dome Lamp	X	X	X
Rear View Mirror, Windshield Mounted	X	X	X
Front Door Jamb Switch L.H.	X	X	X
Rear Door Hinge Cover, Colored Plastic			X
DOOR AND QUARTER PANEL			
Form Molded Plastic Door Trim Panel With Integral Left Hand Map Pocket, Armrest and Door Handle Release Pocket	X	X	X
Bright Aluminum Sill Plates	X	X	X
Form Molded Plastic Rear Quarter Trim Panel	X	X	X
Bright Remote Door Handle	X	X	X
Bright Window Regulator Handle	X	X	X
Black Plastic Window Regulator Knobs	X	X	X
Tail Gate, Deck Lid Garnish Moldings, Colored Plastic		X	X
Door Lock Buttons, Bright Plastic	X	X	X

(c) With sound deadener

EXTRA COST EQUIPMENT

<u>EQUIPMENT</u>	RPO	ACC
<u>MODEL OPTIONS</u>		
GT Sport Equipment option (Coupe or wagon) (Not available with ZJ2) (See page 9 for content)	Z29	
Custom Interior option (Not available with YC6 option) (See page 10 for content)	ZJ1	
Custom Exterior option (Not available with YC6, and Z29 options) (See page 10 for content)	ZJ2	
Vega Estate Wagon (Not available with Z29, ZJ1, ZJ2, B84) (See page 11 for content)	YC6	
<u>POWER TEAMS</u>		
Axle, Rear Hi-altitude	G92	
Axle, Rear, Positraction	G80	
Engine, L-4	L11	
Transmission, 4-Speed	M20	
Transmission, 5-Speed	M75	
Transmission, 3-Speed Automatic	M38	
<u>POWER ASSISTS</u>		
Brakes Power	J50	
Steering, Power	N41	

EXTRA COST EQUIPMENT

<u>EQUIPMENT</u>	<u>RPO</u>	<u>ACC</u>
<u>OTHER OPTIONS</u>		
Air Deflector, Rear (Station Wagon)	C51	ACC
Air Conditioner (See page 12 for content)	C60	
Alarm, Audio Theft		ACC
Antenna, Radio - Rod and Mast		ACC
Bumper Impact Strips, Front and Rear (Requires Front Guards)	VE5	
Carrier, Roof Luggage (Station Wagon)	V55	ACC
Compass, Auto		ACC
Container, Litter		ACC
Cover, Luggage Carrier		ACC
Defogger, Rear Window Electric	C49	
Dispenser, Tissue		ACC
Glass, Tinted Body	A01	
Gauges, Instrument Panel	U14	
Guards, Bumper, Front	V31	ACC
Guards, Door Edge	B93	ACC
Harness, Rear Seat Shoulder		ACC
Heater-Engine Block (Canada only)	K05	ACC
Lamp, Portable Spot		ACC
Lighter, Cigarette		ACC
Mats, Floor, Front and Rear	B37	ACC
Mat, Front Floor		ACC
Mat, Rear Floor		ACC
Mirrors, Dual Sport Outside Rear View, L.H. Remote, R.H. Manual	D35	
Mirror, Fender Mounted Trailering Package Contains 2 Mirrors		ACC
Mirror, Inside Tilt Rear View	D31	
Mirror, Outside Rear View, Right Hand		ACC
Molding, Vinyl Body Side (Adhesive Back)	B84	ACC
Radiator, Heavy Duty	V01	
Radio, AM	U63	ACC
Radio, AM/FM	U69	ACC
Radio, AM/FM Stereo, 2-Speakers	U58	ACC
Radio, AM with Stereo Tape System	UM1	ACC
Radio, AM/FM with Stereo Tape System	UM2	ACC
Ring, Wheel Trim	P06	
Seat Back, Adjustable Driver's (4° Tilt)	AN6	
Seat, Infant Safety		ACC
Speaker, Auxiliary	U80	ACC
Sliding Sun Roof, Manual Control	CF4	
Suspension, Front and Rear Special Performance	F41	
Vent, Side Window LT & RT		ACC
Warmer, Interior Car		ACC
Wheel, Sport Steering	N31	
Wheel Covers, Simulated Wire		ACC
Wheel Covers, Disc	P02	
Window, Swing-Out Rear Quarter (Hatchback Coupe)	A20	
Wheels, Rally II (GT Sport) Includes Trim Rings	N98	

GT SPORT EQUIPMENT RPO Z29

GT SPORT EQUIPMENT OPTION – Z39 (Not available with ZJ2, YC6)

MODEL AVAILABILITY

Vega Hatchback Coupe (1HV77)
Vega Station Wagon (1HV15)

POWER TRAIN AVAILABILITY

Engine	Transmission	Rear Axle
L-4 140 Cu.In. 2-Bbl RPO L11	5-Speed Turbo Hydra-matic	3.42 (3.73 opt.) 2.92 (3.42 opt.)

EQUIPMENT (Used in addition to or in place of standard equipment)

EXTERIOR

- Body side lower molding (Bright and black)
- Dull black dual sport mirrors, LH remote control (RPO D35)
- Front fender "GT" emblem
- Black painted inner surface headlamp bezels
- Bright grille panel lower and headlamp housing molding
- Black windshield wiper blades and arms
- Black windshield reveal moldings
- Black back window reveal or moldings
- Black taillamp bezels (Hatchback Coupe)
- Rear end panel "Vega GT" decal
- Black body side lower
- Black door frame
- Black body lock pillar
- Optional (RPO D88) GT side stripe
- Black paint under back window when RPO D88 GT stripe is specified
- Delete bright door and quarter window moldings
- Delete body rear "Vega" nameplate
- Delete rear quarter "Kammback" nameplate (1HV15)

INTERIOR

Deluxe instrument panel pad and assist handle
Special gauge instrument cluster, clock and wood-grain trim
Sport steering wheel, "GT" emblem
Instrument panel handi-box

CHASSIS

Special front and rear suspension (RPO F41)
A70-13 White letter tires (RPO QAB)
Black Rally II wheels (N98) with bright trim rings (P06)

* Deleted when optional GT side stripe is specified

RPO ZJ1 AND ZJ2

CUSTOM INTERIOR OPTION – ZJ1 (Not available with YC6 option)

MODEL AVAILABILITY

Vega – Notchback Coupe (1HV11)
Vega – Hatchback Coupe (1HV77)
Vega – Station Wagon (1HV15)

EQUIPMENT (Used in addition to or in place of standard equipment)

INTERIOR

Deluxe cloth or vinyl seat trim (Y02-Y03)
Soft door trim panel with cut-sewn map pocket (Y10)
Deluxe instrument panel pad and assist handle
Acoustic package
Mirror, inside tilt rear view (RPO D31)
Ash tray on rear quarter trim panel (both sides)
Chrome transmission control trim plate
Hood insulator
Adjustable passenger seat (1HV11)
Carpet, load floor (1HV77)
R.H. door jamb switch
Mini-console low gloss woodgrain applique (a)
Luggage compartment mat (1HV11) Canada only.

(a) Included when automatic transmission is specified.

CUSTOM EXTERIOR OPTION – ZJ2 (Not available with YC6, Z29 options)

MODEL AVAILABILITY

Vega – Notchback Coupe (1HV11)
Vega – Hatchback Coupe (1HV77)
Vega – Station Wagon (1HV15)

EQUIPMENT (Used in addition to or in place of standard equipment)

EXTERIOR

Molding, lower body side (Bright and black painted)
Wheel opening moldings, front and rear (RPO B96)
Black painted body side lower
Outside door handle, colored insert, body color
Bright belt reveal molding (hatchback coupe only)
Bright grille panel lower and headlamp housing molding
Decor Group (RPO YE4) (1HV11) (Consists of bright side window moldings and Pass. seat adjuster)

VEGA ESTATE – RPO YC6 (Not available with ZJ1, ZJ2, B84, Z29)

AVAILABILITY

Vega Station Wagon (1HV15)

CONTENT (in addition to or in place of standard equipment)

EXTERIOR

Charter oak woodgrain with Malacca woodgrain outline moldings
Wheel covers (RPO P02)
Rear quarter "Estate" nameplate
Gas cap woodgrain

INTERIOR

Deluxe seats and trim
Deluxe instrument panel pad and assist handle
Sport steering wheel (RPO N31)
2-Position adjustable driver seat back (RPO AN6)
Custom door and quarter panel trim
Rear quarter panel ash trays
Day/Night inside rear view mirror (RPO D31)
R.H. door jamb switch

FOUR SEASON (RPO C60)

Integral air cooling and heater system. Manually controlled by two horizontal levers on instrument control panel, plus 4-speed fan switch. Upper lever operates compressor and air selector doors; lower lever controls air temperature from instrument panel and side outlets.

BASIC COMPONENTS

Control panel, evaporator, blower, condenser, receiver-dehydrator, refrigerant (freon) tank, air intake assembly and duct assembly for both systems.

EQUIPMENT (Used in addition to or in place of base equipment)

CHASSIS

Rear Axle Ratio - Refer to Power Trains Section

POWER TRAINS

Fan	5 Flex-blade, plastic
Crankshaft Pulley	Single two groove pulley
Compressor & Crankshaft Belt	One
Generator	55 Ampere
Radiator	Heavier duty

DIMENSIONS AND WEIGHTS

INTERIOR DIMENSIONS	2
LUGGAGE CAPACITY	3
STATION WAGON AND HATCHBACK COUPE CARGO SPACE ..	3
EXTERIOR DIMENSIONS	4, 5
VEHICLE WEIGHTS	6
OPTIONAL EQUIPMENT WEIGHTS	6

INTERIOR DIMENSIONS

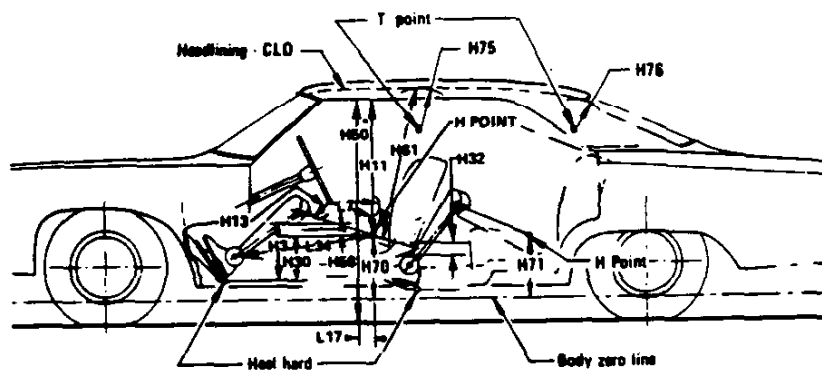

FRONT COMPARTMENT

CODE	DESCRIPTION	2-DOOR COUPE 1HV11	2-DOOR COUPE 1HV77	2-DOOR WAGON 1HV15
H-3	Seat cushion height	10.5	10.2	10.5
H11	Entrance height	30.6	29.6	30.6
H13	Steering wheel thigh clearance	3.4	3.5	3.4
H30	H point to heel point	8.1	7.7	8.1
H32	Seat cushion deflection		3.0	
H50	Upper body opening to ground	47.2	45.9	47.3
H58	H point rise		1.0	
H61	Effective headroom	38.4	37.0	38.5
H70	H point to body O line	11.7	11.4	11.7
H75	Effective 'T' point headroom	38.6	37.2	38.6
W3	Shoulder room		51.3	
W5	Hip room	46.9	47.2	46.9
L7	Steering wheel torso clearance	14.1	14.3	14.1
L17	H point travel		6.5	
L34	Effective leg room	42.9	42.8	42.9

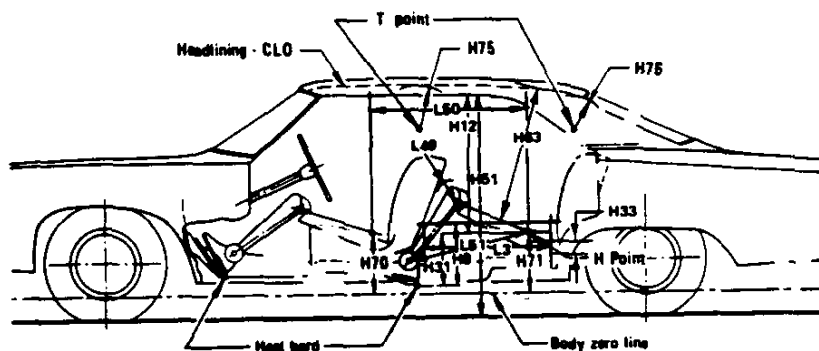

REAR COMPARTMENT

H8	Seat cushion height		9.7	
H12	Entrance height			
H31	H point to heel point	9.0		8.5
H33	Seat cushion deflection	4.2		4.7
H51	Upper body opening to ground			
H63	Effective headroom	39.4	37.1	40.1
H71	H point to body O line	9.9		9.4
H76	Effective 'T' point headroom	39.4	36.3	40.3
W4	Shoulder room		49.2	
W6	Hip room		42.5	
L63	Rear compartment room	25.1	24.3	24.5
L50	H point couple distance	27.0		27.4
L51	Effective leg room	29.1	30.1	30.2

INTERIOR DIMENSIONS

LUGGAGE COMPARTMENT

CODE	DESCRIPTION	2-DOOR COUPE 1HV11	2-DOOR COUPE 1HV77	2-DOOR WAGON 1HV15
H195	Liftover height	29.4		22.7
V1	Usable luggage capacity (cu.ft.)	9.3	-	-

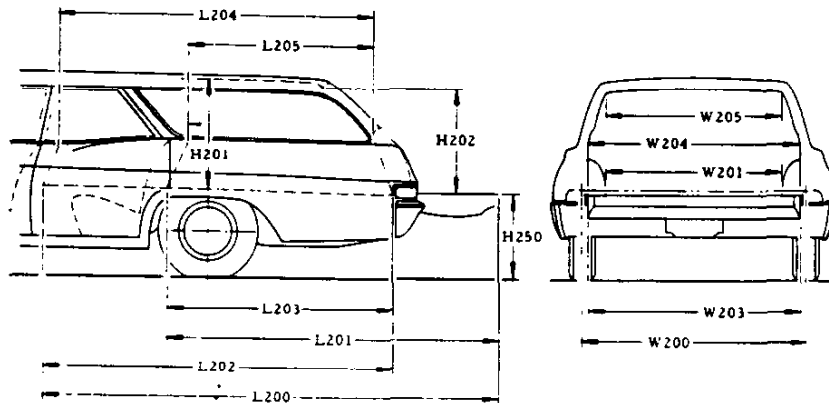

STATION WAGON CARGO SPACE

H201	Maximum cargo height	-	28.6
H202	Rear opening height	-	25.7
H250	Tailgate to ground height	-	22.7
W200	Cargo width-front	-	46.7
W201	Cargo width-wheelhouse	-	42.5
W203	Rear opening width at floor	-	41.4
W204	Rear opening width at belt	-	47.0
W205	Rear opening width above belt	-	34.1
L200	Maximum cargo length-front seat	-	65.0
L201	Maximum cargo length-second seat	-	37.8
L202	Cargo length at floor-front seat	-	65.3
L203	Cargo length at floor-second seat	-	38.1
L204	Cargo length at belt-front seat	-	57.2
L205	Cargo length at belt-second seat	-	30.9
V2	Total cargo index volume (cu.ft.)	-	46.6

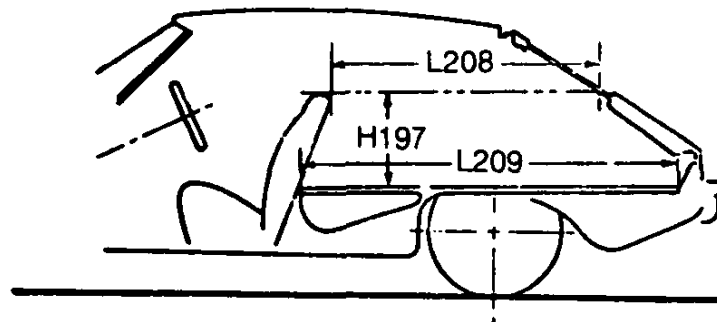

HATCHBACK CARGO SPACE

W4	Shoulder room - rear	49.2
H197	Front seat back to load floor height	18.1
L208	Cargo length at - front seat back height	37.6
L209	Cargo length at floor - front	65.0
V3	Total hatchback - cargo index volume (cu.ft.)	26.5

EXTERIOR DIMENSIONS

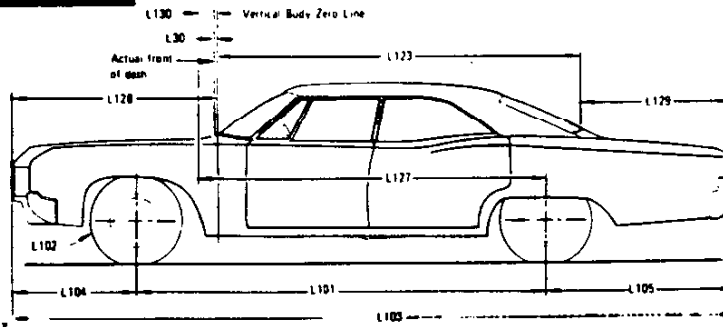

LENGTH

CODE	DESCRIPTION	2-DOOR COUPE 1HV11	2-DOOR COUPE 1HV77	2-DOOR WAGON 1HV15
L101	Wheelbase	97.0		
L102	Tire size (standard)	A78-13B		
L103	Overall length	175.4 (With I/Strips & Guards 176.4)		
L104	Overhang, front	35.2 (With I/Strips & Guards 35.7)		
L105	Overhang, rear	43.2 (With I/Strips 43.7)		
-	Overall length - less bumpers	169.0		
L123	Body upper structure length at car center line	93.2	95.2	108.0
L127	Body O line to C/L of rear wheels	86.0		
L128	Front end length at center line	52.8		
L129	Rear end length at center line	20.6	18.6	--
L125	Body zero plane to windshield cowl point	10.9		
L30	Body O line to actual front of dash	- 0.7		

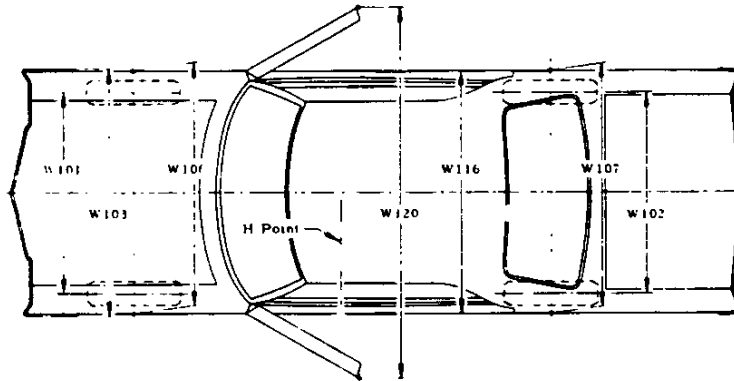

WIDTHS

W101	Tread - front	54.8
W102	Tread - rear	53.6
W103	Maximum overall width of car	65.4
W106	Front fender overall width	65.3
W107	Rear fender overall width	65.3
W116	Maximum overall width of body	65.4
W120	Overall car width, front doors open	146.8

EXTERIOR DIMENSIONS

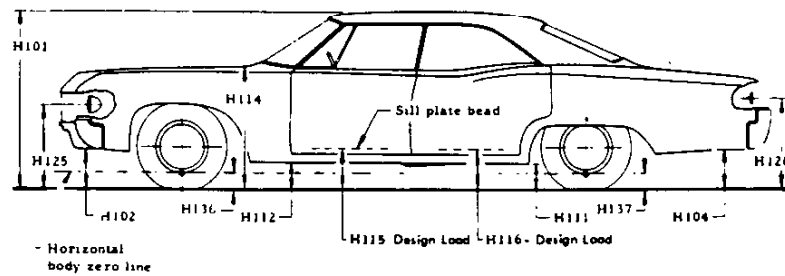

HEIGHTS

CODE	DESCRIPTION	2-DOOR COUPE 1HV11	2-DOOR COUPE 1HV77	2-DOOR WAGON 1HV15
H101	Overall height (design)	51.8	50.0	51.8
H102	Front bumper to ground	14.8	14.9	14.8
H104	Rear bumper to ground		13.2	
H111	Rocker panel to ground - rear		6.2	
H112	Rocker panel to ground - front		6.6	
H114	Hood at rear to ground		35.2	
H115	Step height - front (design)		11.4	
H125	Headlamp to ground	26.5	26.6	26.5
H126	Tail lamp to ground		25.5	24.9
H136	Body O line to ground - front		4.9	5.0
H137	Body O line to ground - rear		4.8	4.9

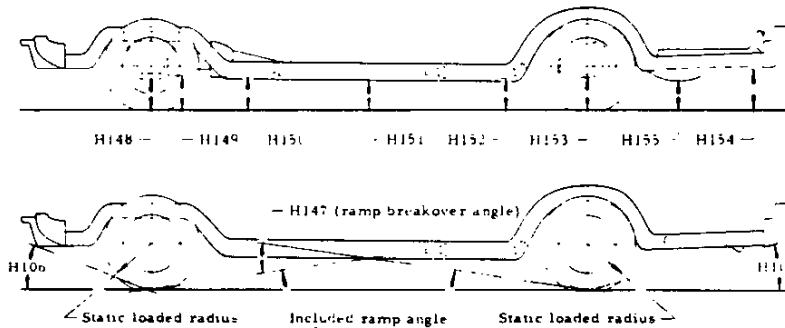

CLEARANCES

H106	Angle of approach (degrees)	20°26'	20°25'	20°23'
H107	Angle of departure (degrees)	21°36'	21°37'	20°35'
H147	Ramp breakover angle (degrees)		15°21'	
H148	Front suspension to ground		6.1	
H149	Oil pan to ground	5.1	5.2	5.1
H150	Flywheel housing to ground	5.3	5.4	5.3
H151	Frame to ground		6.4	
H152	Exhaust system to ground		4.9	
H153	Rear axle to ground		6.1	
H154	Fuel tank to ground		8.4	
H156	Minimum ground clearance		4.8(a)	

(a) Catalytic converter

VEHICLE WEIGHTS

VEGA

MODEL SYMBOL	VEHICLE TYPE Description	SHIPPING WEIGHT			CURB WEIGHT		
		Front	Rear	Total	Front	Rear	Total
1HV11	2-Door Notchback (Coupe)	1362	1097	2459	1343	1196	2539
1HV77	2-Door Hatchback (Coupe)	1374	1148	2522	1356	1246	2602
1HV15	2-Door Station Wagon	1358	1204	2562	1340	1302	2642

SHIPPING WEIGHT: Weight of basic vehicle with regular equipment, including grease, oil and (3) gallons of gasoline, and engine coolant to capacity.

CURB WEIGHT: Shipping weight plus gasoline to capacity.

For total shipping, and curb, weights of vehicles equipped with the following options, add to, or deduct from, the base vehicle weight (lbs.).

OPTIONAL EQUIPMENT

RPO	OPTION	WITH	WEIGHT
B37	Floor Mats, Front and Rear		+ 7
C60	Air Conditioning		+ 70
F41	Spec Perf Frt-Rr Suspension		+ 22
J50	Power Brakes		+ 8
N41	Power Steering		+ 30
P06	Wheel Trim Ring		+ 6
U58	Radio AM/FM Stereo		+ 9
U63	Radio AM Pushbutton		+ 6
U69	Radio AM/FM Pushbutton		+ 7
V55	Roof Luggage Carrier		+ 12
ZJ1	Custom Interior	Sedan, Coupe and Wagon	+ 6
Z29	Special GT Coupe		+ 6
M38	Turbo Hydra-matic Transmission		+ 13
M75	5-Speed Transmission		- 14

BODY

EXTERIOR PAINT PROCESS	2
EXTERIOR-INTERIOR COLORS	3, 4, 5
BODY CONSTRUCTION AND GLASS AREA	6

EXTERIOR PAINT PROCESS

ELPO PAINT PROCESS

Major advances in the painting process of Vega bodies contribute significantly to elimination of rust and corrosion. This technique, called "Elpo", paints the bodies by electricity. Technically the name is "Electrophoretic Deposition of Polymers". It applies a smooth, even, and continuous prime coat to the entire body including hidden inner surfaces and corners automatically without conventional spraying.

Elpo deposits prime coat to the complete body surface by submerging it into a large tank filled with a solution composed of paint particles suspended in water. The paint primer particles are given a negative electrical charge by the tank which also serves as a cathode, with the body itself receiving a positive electrical charge. As the body is submerged, charged primer particles are attracted to the metal surfaces through a principle known as "Electrophoresis".

A seven-stage zinc phosphate rustproofing process is given the body before it reaches the Elpo installation. A conveyor then transports the bodies downward into a tank for the primer coating. The body is submerged for about two minutes and upon emerging goes through a rocking movement to carry away excess liquid.

The electro-coating process causes even the most remote inner surfaces to be coated with dark brown primer, and all edges and complex shapes coated with the same thickness as exposed flat surfaces.

The new primer paint system replaces the spray gun and paint booth priming operations.

Subsequent stages of the paint process include application of a primer-surfacer baking, wet sanding and sealer coating, ending with a topcoat of long lasting acrylic lacquer which is baked in an oven at 300 degrees.

EXTERIOR-INTERIOR COLORS

1977 VEGA
1HV15 & 77 "GT STRIPE" (RPO D88)
EXTERIOR COLOR & STRIPE COMBINATION

EXTERIOR BODY COLOR		STRIPE COLOR
White	11	Black
Silver Met.	13	Black
Black	19	Gold
Lt. Blue	21	Black
Dk. Blue Met.	29	Black
Lt. Lime	32	Black
Firethorn Met.	36	Black
Dk. Aqua Met.	38	Black
Bright Yellow	51	Black
Lt. Buckskin	61	Black
Bright Orange	64	Black
Brown Met.	69	Gold
Red (Light)	75	Black
Orange Met.	78	Black

NOTE: Rear end "GT" decal color to match stripe.

STRIPE IDENTIFICATION

19A Black WML 848 (60 Units of Gloss)
54A Gold WML 4948 (60 Units of Gloss)

EXTERIOR-INTERIOR COLORS

1977 VEGA 'H' INTERIOR-EXTERIOR COLOR COMBINATIONS

MODEL	Seat Type	INTERIOR TRIM				
		Black		Light Blue	Light Buckskin	
		Cloth	Vinyl	Vinyl	Cloth	Vinyl
Vega Standard - 1HV00						
Notchback (11)	(A51) Bucket	19B	19R		64B	64R
Hatchback (77)	(A51) Bucket	19B	19R		64B	64R
Station Wagon (15)	(A51) Bucket	19B	19R		64B	64R
Vega Custom - 1HV00						
Notchback (11)	(A51) Bucket					
Hatchback (77)	(A51) Bucket		19W	24W	64D	64W
Station Wagon (15)	(A51) Bucket		19W	24W	64D	64W
EXTERIOR COLOR	Color Code	Black		Light Blue	Light Buckskin	
White	11	R		R		R
Silver Metallic	13	R		-		-
Black	19	R		A		R
Light Blue	21	R		-		-
Dark Blue Metallic	29	A		R		-
Light Lime	32	R		-		-
Firethorn Metallic	36	A		-		R
Dark Aqua Metallic	38	A		-		A
Bright Yellow	51	R		-		-
Light Buckskin	61	R		-		R
Bright Orange	64	R		-		R
Brown Metallic	69	-		-		R
Light Red	75	A		-		R
Orange Metallic	78	R		-		R

R - Recommended
A - Acceptable

CLOTH AND VINYL USAGE

R-Plisse vinyl, Wallaby bolsters
W-Oxen vinyl, Oxen bolsters
B-Remington, 721 WC, woven cloth; Wallaby bolsters
D-Radcliffe, 722 WC, woven sport cloth; Radcliffe bolsters

Override RPO ZP2 will be provided to permit ordering of any interior-exterior color combination.

EXTERIOR-INTERIOR COLORS

1977 VEGA 'H' INTERIOR-EXTERIOR COLOR COMBINATIONS

MODEL	Seat Type	INTERIOR TRIM						
		Dark Firethorn		White				
		Cloth	Vinyl	† Vinyl /Black	† Vinyl /Dark Blue	† Vinyl /Dark Firethorn	† Vinyl /Dark Aqua	† Vinyl /Dark Saddle
Vega Standard – 1HV00								
Notchback (11)	(A51) Bucket		71R					
Hatchback (77)	(A51) Bucket		71R					
Station Wagon (15)	(A51) Bucket		71R					
Vega Custom – 1HV00								
Notchback (11)	(A51) Bucket	71D	71W	11W	02W	07W	03W	06W
Hatchback (77)	(A51) Bucket	71D	71W	11W	02W	07W	03W	06W
Station Wagon (15)	(A51) Bucket	71D	71W	11W	02W	07W	03W	06W

EXTERIOR COLOR	Color Code	Dark Firethorn	White/Black	White/Dk. Blue (1)	White/Dk. Firethorn	White/Dk. Aqua	White/Dk. Saddle
White	11	R	R	R	R	R	R
Silver Metallic	13	R	R	–	–	–	–
Black	19	R	R	–	R	R	R
Light Blue	21	–	R	R	–	–	–
Dark Blue Metallic	29	–	A	R	–	–	–
Light Lime	32	–	R	–	–	–	–
Firethorn Metallic	36	R	A	–	R	–	–
Dark Aqua Metallic	38	–	R	–	–	R	–
Bright Yellow	51	–	R	–	–	–	–
Light Buckskin	61	R	A	–	–	–	R
Bright Orange	64	–	R	–	–	–	–
Brown Metallic	69	–	A	–	–	–	R
Light Red	75	R	A	–	R	–	–
Orange Metallic	78	–	R	–	–	–	–

R – Recommended

A – Acceptable

Override RPO ZP2 will be provided to permit ordering of any interior-exterior color combination.

CLOTH AND VINYL USAGE

R–Plisse vinyl, Wallaby bolsters

W–Oxen vinyl, Oxen bolsters

B–Remington, 721 WC, woven cloth; Wallaby bolsters

D–Radcliffe, 722 WC, woven sport cloth; Radcliffe bolsters

- NOTES: 11W † – White vinyl interior with Black Instrument Panel upper and lower, Carpet, Cowl Kick Panel, and Load Area or Package Shelf.
- 02W † – White vinyl interior with Dark Blue Instrument Panel upper and lower, Carpet, Cowl Kick Panel, and Load Area or Package Shelf.
- 07W † – White vinyl interior with Dark Firethorn Instrument Panel upper and lower, Carpet, Cowl Kick Panel, and Load Area or Package Shelf.
- 03W † – White vinyl interior with Dark Aqua Instrument Panel upper and lower, Carpet, Cowl Kick Panel, and Load Area or Package Shelf.
- 06W † – White vinyl interior with Dark Saddle Instrument Panel upper and lower, Carpet, Cowl Kick Panel, and Load Area or Package Shelf.

BODY CONSTRUCTION AND GLASS AREA

GENERAL

Construction Body-frame integral, using large individual body panels welded together forming complete sub-assemblies. All major sub-assemblies are double panel construction except underbody and rear end panel. The full roof panel subassembly is formed to provide front and rear headers and side rails. Exterior front end sheet metal panels are removable with bolt on fenders. Main front end structure is welded to body proper and forms the base for attachment of engine, front suspension, steering and front end sheet metal. The flush-dry rocker panel system, plastic valance inner fender panels and the Elpo paint process provide corrosion protection to the entire body. Additional protection is provided by use of a zinc rich primer and hot wax.

DOORS

Type Double panel construction, hinged at front. Side guard beams. Standard spring loaded hold-open feature with two position detent. Welded-on strap type hinges.
 Handles Flush lift bars
 Glass Full, curved ventless

HOOD

Type Double panel construction, front hinged, pop-up springs over-center type locking support on right side, prop rod holds hood open for engine compartment access.
 Release Internal, lever located under instrument panel, left of steering column.

VENTILATION

High Level Air Intake for Passenger
 Compartment Double wall plenum chamber, providing washing and air drying of rocker panels for corrosion resistance.
 Powered System Positive, low blower speed activated thru ignition switch.

SEATS

Type Bucket seats, full foam molded construction with integral head restraints. Coupe and station wagon models folding second seats standard equipment.

WINDSHIELD WIPERS AND WASHERS

Type Dual 2-speed electric with 16" blades
 Linkage Parallel acting
 Washer System Electric, dual spray

HEADLIGHTS

Type 7" Power Beam single headlamps

SPARE TIRE MOUNT

Location
 Sedan In well in trunk floor
 Remainder Under floor of luggage compartment
 Tools Bumper jack with combination lever handle and wheel nut wrench.

REAR END COVER

Model Availability Station wagon hatch, with torque rods counter balanced to aid in opening and closing with positive hold open links.
 Sedan Trunk Lid Counter balanced torque rods
 Coupe Telescoping gas springs

BODY GLASS VISIBILITY AREA

	MODELS		
	11	77	15
Windshield	1116.2	1143.9	1116.2
Front Door	956.4	846.2	956.4
Rear Quarter	589.0	488.2	1105.6
Rear Window	973.8	1071.3	662.5
Total Area (Sq.In.)	3635.4	3549.6	3840.7

Type, Windshield Curved thin laminated plate
 Sides and Rear Curved tempered safety plate
 Rear Quarter Windows Curved stationary

CHASSIS

FRAME AND FRONT SUSPENSION	2
STEERING, DRIVELINE, WHEELS AND TIRES	3
REAR AXLE AND SUSPENSION	4
BRAKES	5
BULBS AND LAMPS	6
FUSES AND CIRCUIT BREAKERS	7

FRONT SUSPENSION

FRAME

Description Body-frame integral

FRONT SUSPENSION

Description Independent, SLA type, coil springs with center mounted shock absorbers, spherical joint steering knuckle.

Wheel Travel (design)

Total 5.44
 Jounce 1.94
 Rebound 3.50
 Wheel to spring travel ratio 1.977

CONTROL ARMS

Description Reinforced steel stamping with pre-loaded steel encased rubber bushings at pivot.

STEERING KNUCKLES

Description Cast nodular iron with pressed-in spindle, integral brake caliper mounting pads and integral steering knuckle arm.

Spindle Diameters

Inner bearing 1.25
 Outer bearing 0.6875

Spindle Thread Size 11/16-20 NEF-3 (modified)

Wheel Bearings

Type, inner & outer Taper roller

SPHERICAL JOINTS

Type Ball stud
 Upper Compression
 Lower Tension
 Bearing Surfaces
 Upper & Lower Sintered iron

SHOCK ABSORBERS

Type Direct, double acting, hydraulic
 Piston Diameter 1.00

FRONT WHEEL ALIGNMENT (Design)

Caster (degrees) N3/4 ± 1
 Camber (degrees) P1/2 ± 3/4
 Toe-In (total) 1/4 ± 1/16
 Steering axis inclination 8.55 @ 25° camber

STABILIZER BAR (Used with special performance

option RPO F41)

Type Link
 Material HR steel
 Diameter 0.875
 Bushing Material Rubber

GENERAL SUSPENSION PROVISIONS

Anti-dive control Angle of front upper control arm

FRONT SPRINGS

Selected from a family of coil springs by Electronic Data Processing which identifies the correct springs for the weight of the vehicle including optional equipment ordered by the customer.

FRONT SPRING SPECIFICATIONS

Part Number	Assy. Code	Cut-Off Length	Wire Dia.	Total Coils	Deflection Rate (Lbs./In.)	HEIGHTS	
						Free	Working (In. @ Lbs.)
346952	DD	107.33	.574	8.50	325	13.51	8.70 @ 1555
346953	FA	107.36	.574	8.50	325	13.71	8.70 @ 1620
346954	FB	107.39	.574	8.50	325	13.91	8.70 @ 1685
354135	AOJ	98.58	.562	7.61	325	12.91	8.70 @ 1360
354136	ANB	98.61	.562	7.61	325	13.11	8.70 @ 1425
354137	ANC	98.63	.562	7.61	325	13.31	8.70 @ 1490
362199	AOK	98.88	.573	7.61	350	13.10	8.70 @ 1530
362200	AOM	98.91	.573	7.61	350	13.30	8.70 @ 1600
370904	AON	107.64	.586	8.50	350	13.50	8.70 @ 1670
370906	AOR	107.67	.586	8.50	350	13.70	8.70 @ 1740
370907	AOS	114.40	.599	9.00	350	13.90	8.70 @ 1810
370908	AOT	114.70	.610	9.00	375	13.74	8.70 @ 1880
370909	AOU	116.08	.613	9.10	375	13.93	8.70 @ 1950
370910	AOW	121.51	.622	9.50	375	14.11	8.70 @ 2020
370911	AOX	121.53	.622	9.50	375	14.30	8.70 @ 2090
378524	AOZ	116.77	.591	9.20	325	14.10	8.70 @ 1750
462542	AXK	97.63	.571	7.52	350	12.90	8.70 @ 1460
462543	AXM	97.61	.571	7.52	350	12.70	8.70 @ 1390

STEERING, DRIVELINE, WHEELS AND TIRES

STEERING

Wheel	
Type	Round with center shroud
Diameter	15.25
Column	Energy absorbing - mast jacket, tube and steering shaft designed to collapse under various front impact conditions.
Gear - Type	
Manual (Std.)	Semi-reversible gear with ball-nut driven by recirculating anti-friction bearings
Power (Optional)	Same as manual except also has integral power piston. Hydraulic pressure provided from a vane type pump.
Ratios, Gear	
Manual	20.9:1
Power	16.0:1 on center to 13.0:1
Ratios, Overall	
Manual	22.5:1
Power	16.5:1 on center to 13.5:1
Number of wheel turns, lock to lock	
Manual	4.4
Power	2.82
Linkage	Parallelogram type, ahead of front wheels
Turning Diameters	
Outside front, wall to wall	38.4
Outside front, curb to curb	35.8
Inside rear, wall to wall	10.95
Inside rear, curb to curb	10.60

DRIVELINE

Propeller Shaft	Tubular
Number Used	One
Diameter (O.D.)	2.75
Wall Thickness	0.065
Length (C/L of U joints)	
4-Spd. Man. & Auto. Trans.	48.85
5-Spd. Man. Trans.	44.78
Universal Joints	
Type	Cross
Number Used	Two
Bearings	Prepacked, anti-friction

WHEELS

Type	Short spoke spider
Rim Size	13 x 5
Offset	0.20
Attachment to Hub	
Thread Size	7/16-20 UNF 2B
Bolt circle diameter	4.00

TIRES, STANDARD EQUIPMENT

A78 x 13B Bias Ply	
Static loaded radius	10.98
Loaded rev/mi @ 45 mph	889
Capacity @ 24 psi	900

TIRES, OPTIONAL EQUIPMENT

BR78 x 13B Steel Belted Radial	
Static loaded radius	10.61
Loaded rev/mi @ 45 mph	878
Capacity @ 24 psi	980
BR78 x 13C Steel Belted Radial	
Static loaded radius	10.71
Loaded rev/mi @ 45 mph	876
Capacity @ 24 psi	980
BR70 x 13C Steel Belted Radial (White letter)	
Static loaded radius	10.91
Loaded rev/mi @ 45 mph	870
Capacity @ 24 psi	980
A70 x 13B Bias Belted	
Static loaded radius	11.00
Loaded rev/mi @ 45 mph	893
Capacity @ 24 psi	900

REAR AXLE AND SUSPENSION

REAR AXLE

Description Three-piece housing includes integral cast iron differential carrier and housing with two pressed-in and welded steel tubes. Semi-floating axle shafts. Differential carrier contains hypoid overhung pinion and ring gear. Drive pinion supported by two taper roller bearings.

Drive Pinion Vertical Offset
 6.50 Ring Gear 1.00
 7.50 Ring Gear 1.50
 Drive Pinion Bearing Adjustment Shim
 Lubricant
 Type Military spec. MIL-L-2105B
 Viscosity SAE-80
 Capacity (pints) 2.8

AXLE SHAFT

Description Forged and hardened steel with integral drive flange
 Wheel Bearings Single row cylindrical roller
 Oil Seal Steel encased, spring loaded synthetic rubber

RING AND PINION GEAR TOOTH COMBINATIONS

Axle Ratio	Ring Gear Diameter	
2.92	6.50	38, 13
3.42	7.50	41, 12
3.73	7.50	41, 11

POSITRACTION DIFFERENTIAL

Type Cone clutches

REAR SUSPENSION

Description Salisbury rear axle with coil springs; parallel lower control arms, torque arm with track bar.

Wheel Travel (Design)
 Total 7.39
 Jounce 2.75
 Rebound 4.64
 Wheel to spring, travel ratio 0.99:1

SHOCK ABSORBERS

Type Direct, double acting hydraulic
 Piston Diameter 1.00

REAR SPRINGS

Selected from a family of coil springs by Electronic Data Processing which identifies the correct springs for the weight of the vehicle including optional equipment ordered by the customer.

REAR SPRING SPECIFICATIONS

Part Number	Assy. Code	Cut-Off Length	Wire Dia.	Total Coils	Deflection Rate (Lbs./In.)	HEIGHTS	
						Free	Working (In. @ Lbs.)
336877	RW	98.38	.508	6.79	155	12.71	10.24 @ 380
346961	OL	91.79	.474	6.39	130	12.57	10.24 @ 300
346963	OP	98.38	.506	6.79	155	12.71	10.24 @ 380
436964	OR	106.10	.521	7.29	155	13.03	10.24 @ 430
346965	OT	106.14	.521	7.29	155	13.36	10.24 @ 480
3988080	HS	107.06	.499	7.39	130	12.95	10.24 @ 350
3988081	HT	107.11	.499	7.39	130	13.34	10.24 @ 400
3988082	HW	107.17	.499	7.39	130	13.72	10.24 @ 450

BRAKES

GENERAL	Type	Front - Disc; Rear - Drum		
	System	Manual - Standard	Power - Optional	
Front Brakes	Type	Dual circuit hydraulic system with warning light and self-adjusting features		
	Material	Disc - single piston floating caliper		
	Diameter and Width	Cast iron - solid, integral with hub		
	Lining Material	9.88 x 0.50		
	Method of attachment	Semi-metallic		
	Lining size (length x width x thickness)	Inboard	Integral bonding	
		Outboard	4.00 x 1.54 x 0.370	
	Lining area (sq. in.)	4.00 x 1.54 x 0.370		
	Effective area (sq. in.)	22.28		
	Swept area (sq. in.)	22.28		
	Piston diameter	146.94		
		1.875		
Rear Brakes	Type	Drum - composite web cast into rim		
	Material	Web - HR steel; Rim - Cast alloy iron		
	Diameter and Width	9.5 x 2.0		
	Lining material	Molded asbestos		
	Method of attachment	Riveted		
	Lining size (length x width x thickness)	Primary	7.30 x 1.08 x .23	
		Secondary	9.46 x 1.99 x .30	
	Lining area (sq. in.)	62.9		
Effective area (sq. in.)	59.6			
Swept area (sq. in.)	117.77			
Piston diameter	.6875			
Apply System	Master cylinder diameter	0.75		
	Piston travel	1.159		
	Pedal travel	7.50	5.60	
	Pedal ratio	6.47:1	4.00:1	
	Line pressure @ 100 lb. pedal load	1270		
Parking Brake	Type	Mechanical pull rods and cables operate rear service brakes.		
	Control	'ON' warning lamp provided.		
	Total effective area	Lever, floor mounted in center console 59.6		

BULBS AND LAMPS

BULBS AND LAMPS	NUMBER REQUIRED AND TRADE NUMBER	CANDLE POWER PER LAMP
Automatic transmission quadrant	1-194	2
Back-up	2-1156	32
Brake warning	1-194	2
Coolant warning - Low	1-194	2
Directional signal indicators	2-194	2
Dome	1-561	12
Engine warning - Stop	1-194	2
Generator indicator	1-194	2
Glove Box	1-1891	2
Headlamp	2-6012	High beam 60W
		Low beam 50W
Headlamp hi-beam indicator	1-194	2
Heater or A/C control	1-194	2
Instrument cluster	4-194	2
License plate, rear	2-194	2
Parking		
Park		3
Turn	2-1157	32
Radio - RPO U58	1-216 (dial)	3
	1-66 (ind.)	1
Radio - AM	1-1893	2
Radio - AM/FM	1-216	1
Radio - UM1 and/or UM2	1-1893 (dial)	2
	1-DS410 (ind.)	Led (a)
Rear window defogger indicator	1-168	3
Seat belt warning	1-194	2
Side marker - front	2-194	2
Side marker - rear	2-194	2
Tail		
Tail		3
Stop & turn	2-1157	32
Underhood lamp	1-93	15
Windshield Washer	1-194	2

(a) Light emitting diode

FUSES AND CIRCUIT BREAKERS

CIRCUIT	TYPE OF PROTECTION	LOCATION AND CIRCUIT *
Air Conditioning	30 amp fuse	In line
	25 amp fuse	Fuse panel (h)
Automatic trans. indicator	4 amp fuse	Fuse panel (f)
Back-up lamps	20 amp fuse	Fuse panel (b)
Brake warning lamp	10 amp fuse	Fuse panel (c)
Choke pull off solenoid	10 amp fuse	Fuse panel (g)
Cigarette lighter	20 amp fuse	Fuse panel (c)
Clock	20 amp fuse	Fuse panel (e)
Direction signal indicator	20 amp fuse	Fuse panel (b)
Direction signal indicator lamps	20 amp fuse	Fuse panel (b)
Dome lamp	20 amp fuse	Fuse panel (c)
Electric fuel pump	1 amp fuse	Fuse panel
Fuel gauge	10 amp fuse	Fuse panel (c)
Generator indicator lamp	10 amp fuse	Fuse panel (c)
Glove box	20 amp fuse	Fuse panel (c)
Headlamps	Circuit breaker	Light switch
Headlamp hi-beam indicator lamp	Circuit breaker	Light switch
Heater	25 amp fuse	Fuse panel (h)
Heater control lamps	4 amp fuse	Fuse panel (f)
Instrument cluster lamps	4 amp fuse	Fuse panel (f)
Key warning buzzer	20 amp fuse	Fuse panel (e)
License plate lamp	20 amp fuse	Fuse panel (d)
Override relay - headlight	10 amp fuse	Fuse panel (c)
Oil pressure indicator lamp	10 amp fuse	Fuse panel (c)
Park and turn lamp	20 amp fuse	Fuse panel (d)
Radio	10 amp fuse	Fuse panel (g)
Radio lamp	4 amp fuse	Fuse panel (f)
Rear window defogger	Circuit breaker	Firewall
Seat belt warning lamp	10 amp fuse	Fuse panel (c)
Seat belt warning buzzer	10 amp fuse	Fuse panel (c)
Side marker lamps	20 amp fuse	Fuse panel (d)
Stop lamps	20 amp fuse	Fuse panel (a)
Tail, turn lamps	20 amp fuse	Fuse panel (d)
Temperature gauge	10 amp fuse	Fuse panel (c)
Temperature indicator lamp	10 amp fuse	Fuse panel (c)
Traffic hazard indicator	20 amp fuse	Fuse panel (a)
Vacuum advance solenoid	10 amp fuse	Fuse panel (g)
Windshield wiper	25 amp fuse	Fuse panel
Windshield wiper switch	4 amp fuse	Fuse panel (f)
Windshield washer pump	25 amp fuse	Fuse panel

* Letter suffix indicates same circuit



POWER TRAINS

POWER TEAM COMBINATIONS	2
POWER TEAM MULTIPLICATION FACTORS	2
ENGINE DATA AND RATINGS	3
ENGINE SPEED AND PISTON TRAVEL	3
VEHICLE PERFORMANCE FACTORS	4
PRINCIPAL COMPONENTS	5
FUEL SYSTEM	11
EXHAUST SYSTEM	11
EMISSION CONTROL EQUIPMENT	12
LUBRICATION SYSTEM	13
COOLING SYSTEM	13
ELECTRICAL SYSTEM	14
CLUTCHES	15
FOUR AND FIVE-SPEED TRANSMISSIONS	15
TURBO HYDRA-MATIC TRANSMISSION	16

POWER TEAM COMBINATIONS

ENGINE	TRANSMISSION	MODEL APPLICATION	AXLE RATIOS			RING GEAR
			BELOW 4000 FT.		ABOVE 4000 FT. ALT.	
			BASE	OPT.		
140 Cu.In. L4 2.3 Litre (L11) Base—all states	4-Speed (3.11 Low)	All Models	2.92:1	3.42:1	3.42:1	6.50 (a)
	5-Speed (3.40 Low)		3.42:1	3.73:1	—	
	Turbo Hydra-matic		2.92:1	3.42:1	3.42:1	

(a) 7.50 with 3.42 and 3.73 axle ratios

MULTIPLICATION FACTORS

WITH MANUAL TRANSMISSIONS

ENGINE	CARBURETION	TRANSMISSION	TOTAL GEAR REDUCTION					AXLE RATIO	
			1st	2nd	3rd	4th	5th		Rev.
140 Cu.In. L4 RPO L11	2-Barrel	4-Speed	9.08	6.42	4.29	2.92	—	9.08	2.92:1
		5-Speed	11.63	7.11	4.75	3.42	2.74	11.49	3.42:1

WITH AUTOMATIC TRANSMISSION

ENGINE	TRANSMISSION	SELECTOR POSITION	TOTAL TORQUE MULTIPLICATION	AXLE RATIO
140 Cu.In. L4 RPO L11	Turbo Hydra-matic	Drive	19.13:1 - 2.92:1	2.92:1
		Low	19.13:1 - 7.36:1	
		Second	19.13:1 - 4.44:1	
		Reverse	14.72:1 - 5.66:1	

ENGINE DATA AND RATINGS

GENERAL DATA

Engine Type	L4, In-line, OHC	
Piston Displacement (Cu.In.)	140	
Availability	Base (RPO L11)	
Number of Cylinders	Four	
Bore and Stroke (Nominal)	3.501 x 3.625	
Compression Ratio	8.0:1	
Taxable (SAE) Horsepower	19.6	
Firing Order	1-3-4-2	
Idling Speed	Manual (in Neutral)	700
	Automatic (in Drive)	650
Compression Press. (PSI) @ Cranking Speed, Engine Hot	150	
Power Plant Mounting	Two front, one rear	
Measurements	Length	31.70
	Height	28.80
	Width	30.08

ADVERTISED ENGINE RATING

Engine	Base (RPO L11)
Net Brake HP @ RPM	84 @ 4400
Net Torque @ RPM (lb. ft.)	117 @ 2400

ENGINE SPEED AND PISTON TRAVEL

Engine	Base (RPO L11)		
	4-Speed	5-Speed	Turbo Hydra-matic
Transmission	4-Speed	5-Speed	Turbo Hydra-matic
Rear Axle Ratio	2.92:1	3.42:1	2.92:1
Tire Size	A 78-13B		
Crankshaft Revolutions per Mile	2581.3	3023.3	2581.3
Crankshaft RPM @ 1 MPH	Low	133.8	171.3
	Second	94.7	104.8
	Third	63.2	70.0
	Fourth	43.0	50.4
	Fifth	—	32.3
	Reverse	133.8	169.3
Piston Travel (ft/mile)	1559.5	1826.6	1559.5

VEHICLE PERFORMANCE FACTORS

ENGINE	140 CU.IN. 84 HP	140 CU.IN. 84 HP	140 CU.IN. 84 HP
MODEL	1HV11	1HV77	1HV15

4-SPEED TRANSMISSION

Performance Weight (pounds)	3139	3202	3242
Pounds per Net Horsepower	37.37	38.12	38.59
Pounds per Cu.In. Displacement	22.42	22.87	23.16
Net HP per Cu.In. Displacement	.600	.600	.600
Power Displacement (cu.ft./mile)	104.57	104.57	104.57
Displacement Factor (cu.ft./ton mile)	66.63	65.31	64.51

5-SPEED TRANSMISSION

Performance Weight (pounds)	3125	3188	3228
Pounds per Net Horsepower	37.20	37.95	38.43
Pounds per Cu.In. Displacement	22.32	22.77	23.06
Net HP per Cu.In. Displacement	.600	.600	.600
Power Displacement (cu.ft./mile)	122.47	122.47	122.47
Displacement Factor (cu.ft./ton mile)	78.38	76.83	75.88

TURBO HYDRA-MATIC

Performance Weight (pounds)	3152	3215	3255
Pounds per Net horsepower	37.52	38.27	38.75
Pounds per Cu.In. Displacement	22.51	22.96	23.25
Net HP per Cu.In. Displacement	.600	.600	.600
Power Displacement (cu.ft./mile)	104.57	104.57	104.57
Displacement Factor (cu.ft./ton mile)	66.35	65.05	64.25

GLOSSARY

Performance Weight	Curb Weight plus 600 Lb. (weight of four 150 lb. passengers)
Power Displacement	$\frac{\text{Crankshaft Revs/Mi} \times \text{Piston Displacement}}{2 \times 1728}$
Displacement Factor	$\frac{\text{Power Displacement}}{\text{Performance Wt (tons)}}$

PRINCIPAL COMPONENTS

CYLINDER BLOCK

Material	Die cast high-silicon aluminum alloy
Bore Diameter	3.500-3.520
Bore Spacing (C/L to C/L)	4.00
Bearing Caps	5-cast iron 2-bolt attachment
Water Jackets	Full length around each cylinder

CYLINDER HEAD

Material	L4-140 Cu.In.	High chrome cast alloy iron
Construction	L4-140 Cu.In.	Integral valve guide, and camshaft support
Number of bolts	10	
Bolt size	.4375 dia.; 14 threads/inch	

COMBUSTION CHAMBER VOLUME

Total chamber volume of assembled engine with piston at top center	L4-140 Cu.In.	5.07 cu.in.
---	---------------	-------------

INLET MANIFOLD

Material	L4-140 Cu.In.	Cast alloy iron
Type	L4-140 Cu.In.	4-port design temperature controlled by engine coolant

EXHAUST MANIFOLD

Material	L4-140 Cu.In.	Cast alloy iron
Type	L4-140 Cu.In.	4-port, center rear takedown
Outlet Diameter (nominal)	L4-140 Cu.In.	1.75 O.D.

CRANKSHAFT

Material	L4-140 Cu.In.	Cast nodular iron	
Counter Weights	L4-140 Cu.In.	4	
Crankarm Length	L4-140 Cu.In.	1.8125	
Thrust against bearing No. 4	End play	.002 - .008	
Drive Gear	Material	L4-140 Cu.In.	Sintered iron sprocket
Pitch Diameter	L4-140 Cu.In.	2.865	
Width	L4-140 Cu.In.	1.121 - 1.310	
No. of teeth		18	

MAIN BEARINGS

Material	Premium aluminum	
Type	Precision removable	
Clearance	.0003 - .0029	
Theoretical Inner Diameter	2.3004	
Effective Length	No. 1, 2, 3	.752
	No. 4	.760
	No. 5	.864

PRINCIPAL COMPONENTS

CRANKSHAFT AND BEARINGS - L4-140 CU.IN.

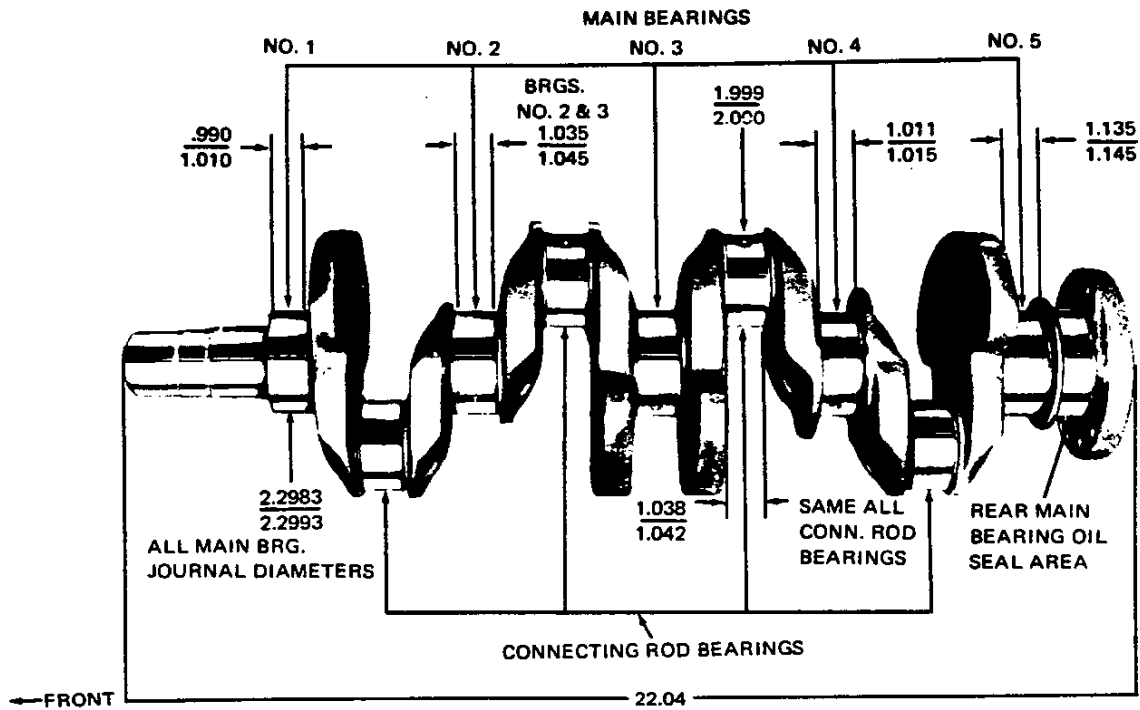

PRINCIPAL COMPONENTS

CAMSHAFT

Location	L4-140 Cu.In.	In cylinder head
Type of drive	L4-140 Cu.In.	Fiberglass reinforced rubber timing belt with sintered iron drive sprockets
Sprocket		
Diameter	L4-140 Cu.In.	5.676-5.681
Width	L4-140 Cu.In.	1.24
Number of teeth	L4-140 Cu.In.	36
Timing belt		
Width	L4-140 Cu.In.	1.031
Number of teeth	L4-140 Cu.In.	91
Pitch	L4-140 Cu.In.	0.500

VALVE TRAIN

Type	L4-140 Cu.In.	Direct action, cam lobes drive tappets that are lash adjusted (L4-140)
Valve Tappets	L4-140 Cu.In.	Hydraulic, direct acting
Valve Lash (Cold)	L4-140 Cu.In.	Zero
Valve and Lobe Lift	L4-140 Cu.In.4000 Inlet; .4150 Exhaust

VALVE SPRINGS

Type	L4-140 Cu.In.	Single spring with flat inner damper
Diameter (I.D.)	L4-140 Cu.In.842
Free length	L4-140 Cu.In.	2.03
Installed length (lb. @ in.)		
Valves closed	L4-140 Cu.In.	71-79 @ 1.746
Valves opened	L4-140 Cu.In.	183-197 @ 1.310
Damper (L4-140)		Fiat steel, 4.5 coils

VALVE TIMING (Crankshaft Degrees - Excluding Ramps)

L4-140 Cu.In.	
Inlet Valve	
Opens - BTC	34°
Closes - ABC	74°
Duration	288°
Exhaust Valve	
Opens - BBC	76°
Closes - ATC	36°
Duration	292°

PRINCIPAL COMPONENTS

CAMSHAFT AND BEARINGS - L4-140 CU. IN.

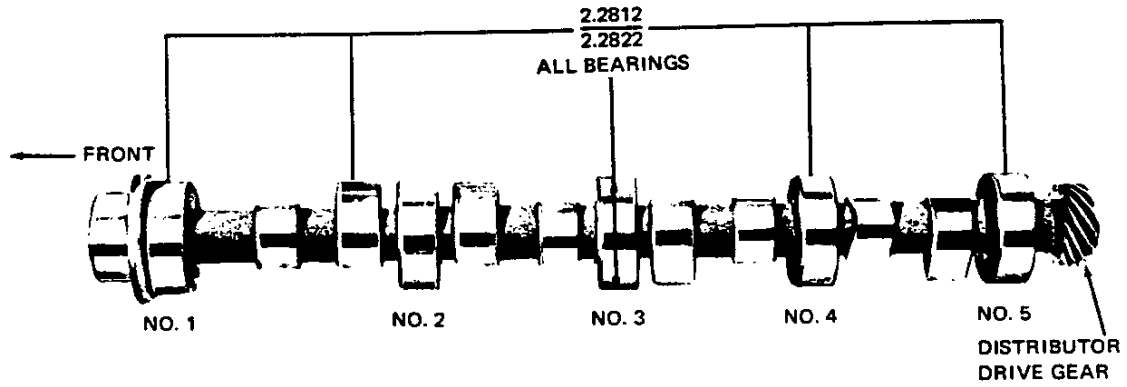

PRINCIPAL COMPONENTS

VALVES - INLET

Material

L4-140 Cu.In. High alloy steel
with aluminum head and seat

VALVE - EXHAUST

Material

L4-140 Cu.In. High alloy steel with
stellite seat, chrome flash stem

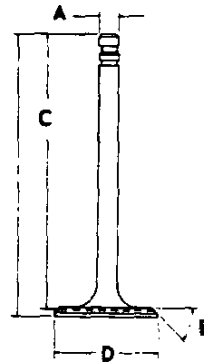
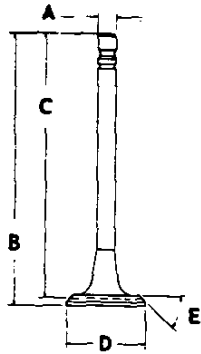

A - Stem Diameter	
L4-140 Cu.In.3410-.3417
B - Overall Length	
L4-140 Cu.In.	4.590-4.610
C - Gage Length	
L4-140 Cu.In.	4.503-4.513
D - Overall Head Diameter	
L4-140 Cu.In.	1.615-1.625
E - Angle of Face	45°
F - Guide Diameter	
L4-140 Cu.In.3427-.3437
G - Angle of Seat	46°
H - Valve Angle	
L4-140 Cu.In.	4°
I - Valve Seat Diameter	
L4-140 Cu.In.	1.575

A - Stem Diameter	
L4-140 Cu.In.3410-.3417
B - Overall Length	
L4-140 Cu.In.	4.576-4.596
C - Gage Length	
L4-140 Cu.In.	4.488-4.498
D - Overall Head Diameter	
L4-140 Cu.In.	1.370-1.380
E - Angle of Face	45°
F - Guide Diameter	
L4-140 Cu.In.3427-.3437
G - Angle of Seat	46°
H - Valve Angle	
L4-140 Cu.In.	4°
I - Valve Seat Diameter	
L4-140 Cu.In.	1.319

PRINCIPAL COMPONENTS

PISTONS

Material	
L4-140 Cu.In.	Cast aluminum alloy
Head Type	
L4-140 Cu.In.	Flat
Skirt	Iron plated open skirt
Top land clearance	
L4-140 Cu.In.	.0300-.0360
Skirt clearance	
L4-140 Cu.In.	.0018-.0028
Compression ring groove depth	
L4-140 Cu.In.	.1800-.1865
Oil ring groove depth	.2050-.2110
Pin bore offset	
L4-140 Cu.In.	.055-.065
Compression height	
L4-140 Cu.In.	1.498-1.502

PISTON PINS

Material	Chromium steel
Pin mounting	Locked in rod by shrink fit
Length	
L4-140 Cu.In.	2.740-2.760
Diameter	.9270-.9273
Clearance in piston	
L4-140 Cu.In.	.00030-.00040

CONNECTING RODS

Material	Drop forged steel
Length (center to center)	5.695-5.705

CONNECTING ROD BEARINGS

Material	Premium aluminum
Type	Precision removable
Clearance	.0007-.0027
Theoretical diameter	2.0017
Effective length	.807
End play	.0009-.0013

COMPRESSION RINGS – UPPER

Material	Cast alloy iron
Type	Straight edge inside of ring
Face	Barrel
Coating	Chrome plated
Width	.0775-.0780
Wall thickness	.154-.164
Gap	.015-.025

COMPRESSION RINGS – LOWER

Material	Cast alloy iron
Type	Inside bevel (top of ring 30 degrees to piston vertical axis)
Face	Barrel
Coating	Chrome flash
Width	.0775-.0780
Wall thickness	.154-.164
Gap	.009-.019

OIL CONTROL RINGS

Type	Multi-piece (two rails and off-spacer)
Material	
Rails	Steel
Spacer	Stainless steel
Width (assembled)	.1870-.1890
Wall thickness	.154-.160
Rail coatings	Chrome plated
Gap	.010-.030

FUEL AND EXHAUST SYSTEMS

FUEL SYSTEM

FUEL TANK

Capacity (gal.) 16 (approximately)
Location In recessed well of rear underbody
Filler Location Right rear quarter

FUEL FILTERS - DUAL

In fuel tank Mesh strainer
In carburetor inlet - 140 Cu.In. Paper element

FUEL PUMP (L4-140 Cu. In.)

Type Electric
Location Mounted in fuel tank
Pressure Range 3.0-4.5 PSI @ 12.5 volts

CHOKE

Type Automatic

AIR CLEANER

Type
L4-140 Cu. In. One piece welded unit
Filter element Oil-wetted paper

CARBURETORS (140 Cu. In.)

Type Two barrel; downdraft
SAE Flange Size 1.25
Throttle Bore Primary 1.24; Secondary 1.40
Venturi Diameter Primary 1.02, Secondary 1.06

EXHAUST SYSTEM

TYPE Single exhaust with
transverse muffler and converter

MUFFLERS

Type Oval, reverse flow
Construction Heads and body joined
by rolled lock seam construction
Head068 sheet steel aluminized
Shell056 sheet steel aluminized
Wrap030 indented asbestos sheet
Cover018 sheet steel aluminized
Length - body 16.00
Height (I.D.) 4.83
Width (I.D.) 9.13

EXHAUST PIPE TO CONVERTER

Material Seamless steel tubing
Dimension (C.O., wall thickness)
L4-140 Cu.In. 2.00 x .045 laminated

EXHAUST PIPE - CONVERTER TO MUFFLER

L4-140 Cu.In. 2.00 x .072

TAIL PIPE

Type
L4-140 Cu.In. Single
Material Steel tubing aluminum coated
L4-140 Cu.In. 1.75 x .057

EMISSION CONTROL EQUIPMENT

SYSTEM APPLICATION

System Type	Engine Adaptation RPO L11
PCV - Positive Crankcase Ventilation	***
EGR - Exhaust Gas Recirculation	***
CHA - Carburetor Hot Air	***
FEC - Fuel Evaporation Control System	***
UFC - Underfloor Converter	***
PAI - Pulse Air Injection	***

- * - Not available in California.
- ** - California only.
- *** - Available - all states.

BASIC FUNCTION OF SYSTEMS

POSITIVE CRANKCASE VENTILATION

Withdraws oil and gas vapors from the various cavities throughout the engine for burning in the combustion cycle.

EXHAUST GAS RECIRCULATION SYSTEM

Meters exhaust gas into induction system for recirculation throughout the combustion cycle to reduce oxides of nitrogen emissions.

CARBURETOR HOT AIR

Meters and mixes heated air with incoming cold air to optimize fuel evaporation.

PULSE AIR INJECTION

Utilizes engine exhaust pulsation to supply air into the cylinder head the the exhaust port.

FUEL EVAPORATION CONTROL SYSTEM

Controls emission of gasoline vapors to the atmosphere by means of an integral separator with the fuel tank that separates vapor from liquid fuel - a filler cap that doesn't permit venting into the atmosphere - a canister for storage of vapors - lines, hoses and valves to control and transport vapors from fuel tank to storage, and finally, to the carburetor for utilization in running the engine.

UNDERFLOOR CONVERTER

The flow of exhaust gases down through the catalyst within the converter, effectively controls the hydrocarbon and carbon monoxide to a more desirable emission.

LUBRICATION AND COOLING SYSTEM

LUBRICATION SYSTEM

GENERAL

Type	Controlled full pressure
Main Bearings	Pressure
Piston Pins	Splash
Cylinder walls	Splash
Camshaft bearings	Pressure
Hydraulic lifters	Splash
Connecting Rods	Pressure
Oil pressure sending unit	Electric opens or closes circuit @ 2 to 6 PSI
Oil Filler	
Cap	Positive seal
Location	Top rear of valve cover

OIL PUMP

Type	Eccentric inside-outside gear; driven by crankshaft
Regulator valve	Opens between 40-45 lbs.
Oil Pressure (lbs. @ engine RPM)	27-41 PSI @ 1000
Intake type	Fixed pickup with screen
Capacity (GPM @ engine RPM)	4.5 gals. @ 2000 RPM

OIL FILTER

Type	Full flow throwaway type
Location	Lower front-left side
Capacity	One pint
By pass valve	Opens between 9 to 11 PSI drop in pressure

LUBRICANT GRADES AND TEMPERATURES

20°F and above	10W-30, 10W-40, 20W-20, 20W-40, 20W-50
0° to 60°F	10W, 5W-30, 10W-30, 10W-40
Below 20°F	5W-20, 5W-30

OIL PAN

Capacity	
Refill	3.5 Quarts
Refill with filter change	4 Quarts
Type of drain plug	Hex head
Drain plug location	Right side bottom rear of pan

COOLING SYSTEM

GENERAL

Type	Pressure, vented thru coolant recovery system
Capacity	8.0 qts.

RADIATOR

Type	Tube and center; cross flow
Distance between fins	.22 Syn. & Auto.
Distance between tubes	.55
Thickness of core	1.24
Frontal area (sq.in.)	202
Radiator cap relief valve	Opens at approximately 15 PSI
Overflow	Separate coolant bottle

THERMOSTAT

Type	Pellet
Begins to open	180°
Fully opened	202°

RADIATOR HOSE

Outlet, Lower (Radiator to Water Pump)	
Type	One, molded; 1.75 I.D.
Inlet, Upper (Thermostat Housing)	
Type	One, molded; 1.28 I.D.

FAN

Number of Blades	5, staggered
Material	Plastic
Diameter	14.0

WATER PUMP

Type	Centrifugal, die cast aluminum housing
Capacity @ 2000 Engine RPM's	
L4-140 Cu.In.	15.6
Water pump/fan drive	Multiple "V" drive in back side of camshaft timing belt

DRAIN LOCATIONS

Engine block	Plug; left side center of block
Radiator-Petcock	Lower, left rear face

ELECTRICAL SYSTEM

SUPPLY SYSTEM

BATTERY
 Type Sealed side terminal
 Number of cells and plates 6 and 48
 Voltage rating and watts 12, 2500
 Cold cranking rating - 60 minutes reverse capacity;
 0°F @ 175 amps; -10°F @ 210 amps
 Terminal Grounded Negative
 Location Right hand front side of
 engine compartment

GENERATOR

Type Diode rectified with integral regulator
 Rating
 Amps 37
 Volts 12
 Drive By fan belt
 Pulley Pitch Diameter 2.70
 Ratio (Gen to Engine Speed) 2.73:1

REGULATOR

Type Micro-circuit unit, integral with generator
 Voltage Regulator
 Voltage 13.8-14.8 @ 85°F

IGNITION SYSTEM

DISTRIBUTORS Refer to chart below

STARTING SYSTEM

STARTING MOTOR
 Rotation (Drive End View) Clockwise
 Test Conditions . . . Engine at operating temperature
No Load Test
 Amps 58-80
 Volts 10.6
 RPM 6750-10500
Motor Drive
 Engagement Solenoid
 Pinion Meshes at Rear
 Pinion Tooth No. 9
 Flywheel Tooth No. 153
 Mounting Bolted to clutch housing

COIL

Type Integral with distributor

SPARK PLUGS

Make & Type
 L4-140 Cu.In. R43TS
 Thread Size (mm) 14
 Gap035
 Torque 25 lb. ft.

CABLE Linen core impregnated
 with electrical conducting material and
 insulation of rubber with neoprene jacket

DISTRIBUTORS	L4-140 Cu. In.	
	Manual Transmission	Automatic Transmission
Model	1110538	1110539
Type	High Energy Ignition	
Centrifugal Advance Begins (RPM)	0° @ 850	0° @ 850
Max Degrees @ RPM	33° @ 4600	32° @ 4400
Vacuum Advance Begins (In. Hg)	0° @ 5	
Max Degrees @ In. Hg	24° @ 10	
Timing (Initial Design Setting) Crankshaft Degrees @ RPM (with vacuum spark line disconnected)	0° @ 700 (2° ADC @ 800)	2° BTC @ 650 (0° @ 650)
Timing Mark Location	Crankshaft Pulley	

NOTE: Items bracketed () are specific to California.

CLUTCHES AND TRANSMISSIONS

CLUTCHES

Engine		L4-140 Cu. In.		
Clutch for		4-Speed	5-Speed	
Type		Single dry disc centrifugal		
Clutch cover & pressure plate	Eff. plate load, lbs.	1250 - 1450		
	Press. plate matl.	Cast iron		
	Clutch spring type	Diaphragm, bent finger design		
	Clutch spring matl.	Heat treated spring steel		
Driven plate	Type	Single disc with two friction surfaces		
	Cushions	Flat spring steel between friction rings		
	Dampers	8 coil springs (4 sets of two)		
	Friction rings	OD	8.0	9.12
		ID	6.0	6.12
Total area sq. in.		43.98	71.82	
Material		Woven type asbestos		
Flywheel	Flywheel Material	Nodular iron		
	Ring gear Material	Heat treated HR steel		
	No. of teeth	153		
	PD	12.75		
	Attachment	Shrink fit		
Bearings	Release	Type	Single row ball	
		Lubrication	None, prepacked	
	Pilot	Type	Bronze bushing	
		Lubrication	None, sintered and oil impregnated	
Controls	Clutch fork	Drop forged steel, pivot mounted on ball		
	Pedal mounting	Pendant, from brace on dash		
	Lubrication	Crossover shaft		
Clutch housing material		Aluminum alloy		

4-SPEED AND 5-SPEED TRANSMISSIONS

Transmission Type		L4-140 Cu. In.		
		4-Speed	5-Speed	
Case material		Aluminum		
Gear Shift	Type	Remote		
	Control	Lever		
	Location	Floor, mounted between seats		
Gears	Type	Helical		
	Material	Forged steel, hardened		
	Synchronization	All forward gears		
	Constant mesh gear	All forward gears		
	Sliding gears	Reverse		
	Ratios	First	3.11	3.40
		Second	2.20	2.08
		Third	1.47	1.39
		Fourth	1.00	1.00
		Fifth	—	0.80
Reverse		3.11	3.36	
Lubricant	Type	Meeting Military Specifications MIL-L-2105-B		
	Capacity (pts)	4		
Extension	Material	Aluminum		
	Oil Seal	Steel encased seal of spring loaded silicone		

TRANSMISSIONS

TURBO HYDRA-MATIC TRANSMISSION

Engine	Displacement (Cu.In.)	L4-140 Base L11		
General Data	Type	Automatic hydraulic torque converter with compound planetary gear system - three forward speeds and reverse.		
	Selector lever	Location	Floor tunnel (a)	
		Operation	Actuates controls by a hydraulic system from pressurized gear type pump	
		Quadrant pattern	P-R-N-D-L2-L1	
	Parking Lock	Type	Locking pawl	
		Operation	Applied by selector lever through manual linkage	
	Method of cooling	Water		
Flywheel assembly	Steel stamping with welded on ring gear			
Hydraulic System	Oil pressure pump	Supplies hydraulic pressure from an engine driven gear type pump		
	Type	Steel spool valve		
	Valves	Manual	Establishes range at transmission operation	
		Pressure regulator	Provides main line pressure	
		Shift (1-2)	Controls oil pressure for transmission shift from 1-2 or 2-1	
		Shift (2-3)	Controls oil pressure for transmission shift from 2-3 or 3-2	
	Modulator	Regulates line pressure with modulator oil pressure which varies with torque to transmission		
	Accumulator	Provides greater flexibility in attaining desired shift quality for various engine requirements		
	Pressure @ Idle (b)	Drive	55	
		L2	80	
L1		80		
Reverse		84		
Converter Assembly	Pump (Drive member)	Multivane type, sheet metal blade spot welded to steel pump housing that is an integral part of the converter housing		
	Turbine (Driven member)	Steel axial flow blades assembled between inner & outer steel shells		
	Stator assembly	Aluminum multivane type blades mounted on a one way (overrunning) roller clutch		
	Stall ratio	2.60		
	Stall speed (RPM)	2450		
	Diameter (nominal)	10.00		
	Planetary Gear Set	Reaction carrier assembly	4 steel pinion gears	
Output carrier assembly		4 steel pinion gears		
Intermediate band		Circular steel with organic lining		
Range		D (Drive)	2.52:1 - 1.52:1 - 1.00:1	
		L2 (Low two)	2.52:1 - 1.52:1	
		L1 (Low one)	2.52:1	
		R (Reverse)	1.94:1	
Servo Unit	Piston with release spring and inner cushion spring			
Case	Material	Aluminum		
	Type	Three, multiple disk		
Clutches	Material	Drive plates	Steel with bonded organic facings	
		Driven plates	Flat steel	
	Forward clutch	3 each drive & driven plates		
	Direct clutch	2 each drive & driven plates		
	Low & Reverse clutch	3 each drive & driven plates		
	Release spring	Radial row steel coil		
Torque Multiplication	Drive (maximum)	6.50:1 to 1.00		
	Low 2	6.50:1 to 1.52		
	Low 1	6.50:1 to 2.52		
	Reverse	3.88 to 1.94		
Governor	Type	Cross-axis centrifugal		
	Operation	Regulates a pressure proportional to car speed which acts upon the (1-2) (2-3) shift and modulator valves		
Lubricant	Type	Dexron		
	Capacity (pints)	Dry	20	
		Refill	8	

(a) Floor mounted automatic mini-console available as an option.

(b) Conditions 600 RPM input