

GENERAL

MODEL IDENTIFICATION	2
SERIAL NUMBERS AND IDENTIFICATION	3
EXTERIOR EQUIPMENT	4
INTERIOR EQUIPMENT	5, 6, 7
EXTRA COST EQUIPMENT	8, 9
CABRIOLET FORMAL ROOF COUPE EQUIPMENT - RPO AB8	10
INTERIOR DECOR AND CONVENIENCE GROUP RPO ZJ3 ..	11
NOVA RALLY RPO Z26	11
AIR CONDITIONING EQUIPMENT	12

MODEL IDENTIFICATION

BODY	SERIES NAME	BODY STYLE	MODEL DESIGNATION	PASS OR SEATS
X-CAR	NOVA	4-Dr. Sedan	1XX69	6
		2-Dr. Coupe	1XX27	6
		2-Dr. Hatchback Coupe	1XX17	6
	NOVA CUSTOM	4-Dr. Sedan	1XY69	6
		2-Dr. Coupe	1XY27	6

SERIAL NUMBERS AND IDENTIFICATION

ONLY BASIC DESIGNATION SHOWN

VEHICLE IDENTIFICATION NUMBER

Vehicle Designation Interpretation

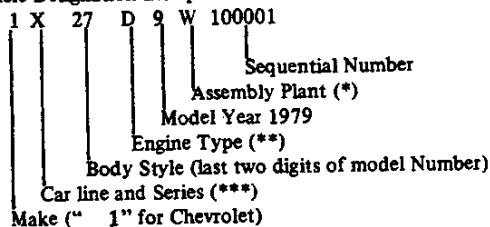

- *W - Willow Run-GMAD T - Tarrytown-GMAD
- **D - L6-250 (115 H.P.) L - V8-350 (170 H.P.)
- U - V8-305 (130 H.P.)
- ***X - Chevy Nova

EXAMPLE: The twenty-fifth Chevrolet vehicle built at Chevrolet-Willow Run if it were a 1XX27 model (Nova Coupe) with a L6-250 (115 H.P.) engine would bear VIN Number 1X27D9W100025.

Location Stamped on plate attached to top left hand of instrument panel.

TRANSMISSION IDENTIFICATION

Example: S9E01

Type Designation	Source Designation	Model Year 1979	Production ^o Month & Date
SF	S (Muncie)	9	E01D*

SF	3-Speed	L-6	S - Muncie
SR	4-Speed	V-8 engine	R - Muncie
6TC	3-Speed Auto.	L-6 engine	B - Parma
6TA		V-8 engine	Y - Toledo

Location:
 3-Speed Stamped on right side of case, at adapter.
 4-Speed Stamped on right side of case, at adapter.
 3-Speed Automatic Stamped on right side of transmission, above filler plug.

o-Month: E denotes May; (see below) 01 denotes 1st day
 Alpha Characters used in identifying the calendar Month

- | | | | |
|--------------|-----------|---------------|--------------|
| A - January | D - April | K - July | R - October |
| B - February | E - May | M - August | S - November |
| C - March | H - June | P - September | T - December |

*-The letter "D" or "N" following the date numerals indicates day or night shift on automatic only.

ENGINE IDENTIFICATION

Example: F1210DKA

Source Designation	Production* Month & Date	Type Designation
F (Flint)	1210	DKA

4.1 L, 250 Cubic Inch L-6 Base Engine (RPO L22)

- DKA - Regular engine, 3-speed
- DKB - Regular engine, 3-speed automatic

5.0 L, 305 Cubic Inch V-8 (RPO LG3)

- DNF - Optional engine, 4-speed
- DNJ - Optional engine, 3-speed automatic

5.7 L, 350 Cubic Inch V-8 (RPO LM1)

- DRY - Optional engine, 3-speed automatic

Location:

- 6-cylinder engine Stamped on pad on right side of cylinder block to rear of distributor
- 8-cylinder engine Stamped on pad at front right side of cylinder block

*-Month: December, 12; 10th day of December, 10.

REAR AXLE IDENTIFICATION

- 2TE - 2.41 Axle
- 2TA - 2.56 Axle
- 2TB - 2.73 Axle
- 2TC - 3.08 Axle

Location, Identification Number
 Bottom left or right of axle tube adjacent to carrier housing.

See Power Train Section for additional information

EXTERIOR EQUIPMENT

EXTERIOR EQUIPMENT

	Standard 1XX00 (17, 27, 69)	Custom 1XY00 (27, 69)	"Nova Rally" RPO Z26 1XX17-27 1XY27
FRONT			
Bumper Filler Panel, Body Color (C)	X-N	X-N	X-N
Bumper Face Bar, Bright Chrome Plated (C)	X	X	X
Grille, Plastic, Chrome Plated (C)	X-N	X-N	X-N
Parking Lamps, Grille Mounted, Vertical, Clear Lens (C)	X-N	X-N	X-N
Headlamp Bezels, Rectangular Chrome Plated (C)	X-N	X-N	X-N
Fender Extensions, Front (C)	X	X	X
Moldings, Bright, Horizontal Along Hood Front Lower Edge (Includes Black "Chevrolet" Script Identification) and at Top and Outboard Sides of Fender Extensions (C)	X	X	X
Emblem, "Nova Rally" in center of Grille (C)			O
REAR			
Molding, Rear Window Reveal, Bright (F)	X	X	X
Rear Lamps (In Rear End Panel), Rectangular, Two-Section With Back-Up Lamp Integral with Inboard Lamp (F & C)	X	X	X
Bumper Face Bar, Bright Chrome Plated (C)	X	X	X
Bumper Filler Panel, Body Colored, Pliable (C)	X	X	X
Nameplate, "Chevrolet", on Deck Lid, Centered Above R.H. Outboard Tail Lamp (F)	X	X	X
Rear End Panel Striping (C)			O
SIDE			
Door Handles, Push-Button, Bright Chrome (F)	X	X	X
Marker Lamps, Front, Bright Bezel and Amber Lens (C)	X	X	X
Marker Lamps, Rear, Bright Bezel and Red Lens (F)	X	X	X
Mirror, Outside Rear View, Rectangular, L.H. (C)	X	X	X
Nameplate "Nova" on Front Fender (C)	X		
Nameplate "Nova Custom" on Front Fender (C)		O	
Hub Caps (C)	X	X	
Glass Separation, Rear Door, Black (69 Only) (F)	X	X	
Emblem, "Nova Rally" on Front Fenders (C)			O
Rally Wheel, with Bright Hub and Trim Ring, Body Color (C)			O-M
Body Side Striping (C)			O

NOTES: "O" indicates specific feature of optional package.
 "M" indicates modified for 1979.
 (C) = Chevrolet item, (F) = Fisher item.
 "N" indicates New for 1979.

INTERIOR EQUIPMENT

INTERIOR EQUIPMENT

	Standard 1XX00 17, 27, 69	Custom Interior 1XY00 27, 69
SEATS AND FLOOR COVERING		
Front Seat Cushion with Full Foam Pad (F)	X	X
Rear Seat Cushion with Full Foam Pad (F)	X	X
Bench Type Front and Rear Seats with Custom Vinyl or Cloth Covering (F)		X
Full-Foam Front Bucket Seats with Integral Head Restraint and Shoulder Belt Guide (RPO) (27 Model only) (F)		X
Black Front Seat Adjuster Handle (F)	X	X
Black Front Seat Back Release Latch (F)	X	X
Folding Rear Seat with Single-Point Hinge, Hatchback Coupe Only (F)	X	
Bright Rear Seat Back Release Latch, Hatchback Coupe Only (F)	X	
Front Bench Seat Head Restraints (all models) with Shoulder Belt Guide (17-27 only) (F)	X	X
Front and Rear Seat Belts (Base), Black, with Black Die-Cast Metal Buckles, Locking Retractors (F)	X	X
Front and Rear Seat Belts (RPO), Color-Coordinated Belts with Color-Keyed Die-Cast Metal Buckles, Roof-Mounted Single Locking Retractors (F)	O	O
Vinyl-On-Felt Treatment for Storage Compartment Under Load Floor - Hatchback Coupe Only (F)	X	
Trim Color Seat Hinge Arm Cover (F) (Base-Black Paint)		X
High Level Acoustic Package (F & C)		X
One-Piece Hood Insulator (C)		X
Cut-Pile Carpet in Passenger Compartment (F)	X	X
Luggage Compartment Mat (Printed Vinyl on Needled Felt) (27-69 Models) (F)	X	X
Carpet Load Floor Covering - Hatchback Coupe Only (F)	X	X

NOTES: (C) Chevrolet Item, (F) Fisher Item
"O" indicates specific feature of optional package

INTERIOR EQUIPMENT

INTERIOR EQUIPMENT

	Standard 1XX00 17, 27, 69	Custom Interior 1XY00 27, 69
INSTRUMENT PANEL AND STEERING WHEEL		
Soft Black Turn Signal and Transmission Shift Lever Knobs (C)	X	X
Steering Column Ignition Switch with Integral Steering Wheel and Transmission Lock (C)	X	X
Black T-Handle Parking Brake Release (C)	X	X
Blended Air Heater (C)	X	X
Two-Speed Windshield Wiper/Washer Illuminated Control (C)	X	X
Ash Tray (C)	X	X
Speedometer, Odometer and Fuel Gage (C)	X	X
Instrument Panel Pad, Color Coordinated (C)	X	X
Clock Hole Cover Plate (C)	X	X
Radio Hole Cover Plate and Light Switch/Windshield Wiper Panel (Color-Coordinated) (C)	X	
Radio Hole Cover Plate and Light Switch/Windshield Wiper Panel (Woodgrain) (C)		X
Glove Compartment Door Lock (C)	X	X
Black, Soft Vinyl Steering Wheel (C)	X	X
Soft Black Steering Wheel Shroud, with gold "Bow-Tie" emblem	X	X
Heater Control Panel Light (C)	X	X
Temperature, Generator, Oil Pressure and Brake Warning Lights (C)	X	X
High-Beam and Turn Signal Indicators (C)	X	X
Black Cowl Vent Control Knobs (F)	X	X
Bright finish Instrument Panel Light Control Knob (C)	X	
Bright finish Radio Control Knobs - RPO (C)	X	
Bright Radio (RPO) and Light Switch Control Knobs with Wood Grain Applique (C)		X
Black Steering Column and Hazard Flasher Knob (C)	X	X
"Fasten Seat Belt" Lamp in Instrument Cluster (C)	X	X
Glove Compartment Light (C)		X
Additional Bright Framing on Instrument Cluster Carrier (C)		X
Instrument Cluster with Wood Grain Accents (C)		X
Cigar Lighter (C)		X

NOTES: (C) Chevrolet Item, (F) Fisher Item

INTERIOR EQUIPMENT

INTERIOR EQUIPMENT

	Standard 1XX00 17, 27, 69	Custom Interior 1XY00 27, 69
ROOF AND PILLARS		
Hardboard Formed Headlining, Perforated (F)	X	
Scored and Folded Foam Core with Non-Perforated Cloth Covered Headlining (F)		X
Trim Color Windshield, Roof Rail and Rear Window Moldings (F) . . .	X	X
Black Rear View Mirror Support (F)	X	X
Padded Sunshades with Vinyl Covering (F)	X	
Padded Sunshades with Cloth Covering (F)		X
Trim Color Plastic Coat Hooks (F)	X	X
Left Front Door Jamb Switch (F)	X	X
Right Front Door Jamb Switch (F)		X
Front Seat Shoulder and Lap Belt Motion Sensing Single Retractor Reels with Color Coordinated Covers (F)	X	X
Front Shoulder Belts (base), Black, Non-Detachable (F)	X	X
Front Shoulder Belts (RPO), Color-Coordinated, Non-Detachable (F) . .	X	X
Center Dome Lamp with Bright Bezel (F)	X	X
Black, Textured, Vinyl-Clad 8-Inch Rear View Mirror Bonded to Windshield-Std. Type (F)	X	
Black, Smooth, Vinyl Clad 10-Inch Day-Night Rear View Mirror with Black Padded Edge, Bonded to Windshield (F)		X
DOOR AND QUARTER PANEL		
Color-Coordinated Door Pull Strap attached to Rear Door Trim Panel - 69 Only (F)	X	X
Front Door Padded Armrest with Integral Door Pull Handle (F)	X	X
Flush Mounted Door Opening Handles, Bright, in an Upper, Forward Location (F)	X	X
Black Finished Door Handle Cup (F)	X	
Black Finished Door Handle Cup with Bright Edges (F)		X
High Profile Window Regulators with Clear, Blue Tinted Plastic Control Knobs (F)	X	X
Bright Door Lock Buttons (F)	X	X
Rear Door Padded Armrest with Ash Tray and Integral Door Pull Handle (F)		X
Deluxe Door Trim Panel with Horizontal Simulated Wood Grain Strip (F)		X
Rear Quarter Arm Rest with Ash Tray (F)		X
Plastic Quarter Panel Trim (Coupes) (F)	X	X

NOTES: (C) Chevrolet Item, (F) Fisher Item

EXTRA COST EQUIPMENT

EQUIPMENT	RPO	ACC
Air conditioning, Four-Season: (See page 12 for content)	C60	
Battery, heavy duty	UA1	
Belts, seat and shoulder: in addition to or replacing standard belts.		
Deluxe seat belts and front seat shoulder harness	AK1	
6 Seat and 2 shoulder belts (Bench front seat) or		
5 Seat and 2 shoulder belts (RPO A51 bucket front seats),		
color keyed to interior. Not available with black interior.		
Console, floor - (RPO A51 required) (1XY27 model only)	D55	
Front bucket seats - Special Contour (available with custom only 1XY27 model)	A51	
Glass, Soft-Ray tinted: all windows	A01	
Horns, dual	U05	
Instrumentation, special: (Tachometer package) includes tachometer,		
voltmeter, temperature gage and clock	U14	
Instrumentation special (Econominder package) includes econominder,		
voltmeter and temperature gage	UF7	
Lighting, auxiliary:	TR9	
Courtesy lights		
Right hand front door jamb switch (Standard 1XY00 models)		ACC
Glove compartment light (Standard 1XY00)		ACC
Luggage compartment light (Not available on 1XX17)		
Ash tray light		
Rear door jamb switches (1XX + 1XY69)		
Underhood light		ACC
Headlamp reminder buzzer		
Automatic rear compartment lamp switch (1XX17 only)		
Mirror, vanity visor lighted		ACC
Mirror, rear view, day/night 10" (1XX00 models only) (Base 1XY00 models)	D31	
Molding, wheel opening (Not available with RPO Z26 Nova Rally)	B96	
Moldings, body side (Not available with RPO Z26 Nova Rally)	B84	
Moldings, wide, body side (Not available with RPO Z26 Nova Rally)	BW2	
Moldings, roof drip	B80	
Radiator, heavy duty	V01	
Radio equipment: Radios, pushbutton - Includes concealed w/s antenna		
AM Radio	U63	ACC
AM/FM Radio	U69	ACC
AM Radio and Stereo Tape player	UM1	ACC
AM/FM Stereo Radio and Tape player	UM2	ACC
Speaker, rear seat	U80	ACC
Windshield antenna	U76	
Roof cover, vinyl (Padded type)	C09	
Two-Tone Paint (Not available with RPO Z26)	D99	
Pin striping (Not available with RPO Z26 or RPO B74 wide wheel opening moldings)	D85	
Speed and cruise control (Available only with Automatic Trans.)	K30	
Steering wheel, Comfortilt (Available for all except steering column		
mounted 3-speed manual transmission)	N33	
Suspension, heavy duty front and rear	F40	
Suspension, sports, front and rear (V8 engines only)	F41	
Tire, Stowaway spare (E78-14 or F78-14 B/W on specific 14 x 5 wheel)		
std. equipment on hatchback model, includes refillable CO ₂ Tire inflator bottle	N65	
Wheel covers, (Not available with ZJ7 or Z26 Nova Rally)	P01	ACC
Trim cover, wire wheel (Simulated) (Not available with Z26 Nova Rally)	N95	ACC
Wheels, rally (14 x 6 or 14 x 7 depending on tire size)		
(Not available with Z26 Nova Rally) (included)	ZJ7	
Windshield wipers - intermittent	CD4	
Window - swing out rear quarter (17, 27 models only) (Not available with AB8)		
cabriolet roof)	A20	
FACTORY-INSTALLED REGULAR PRODUCTION TIRES		
FR78 x 14-steel belted - radial ply, White lettered	QBT	
FR78 x 14-steel belted - radial ply, Blackwall	QDV	
FR78 x 14-steel belted - radial ply, White stripe	QDW	
E78 x 14B-bias belted - highway Blackwall	QEG	
E78 x 14B-bias belted - Whitewall, single stripe	QEH	

EXTRA COST EQUIPMENT

EQUIPMENT	RPO	ACC
FEATURE ITEMS		
Deluxe bumpers, front and rear impact strips, front and rear bumper guards (Available on all models)	V30	
Color-keyed floor mats - 2 Front, 2 Rear	B37	ACC
Door edge guards	B93	ACC
Electric clock	U35	ACC
L.H. outside remote-control rear view mirror	D33	ACC
Sport outside rear view mirrors, LH remote control and RH manual (body color)	D35	
Rear window defogger (Forced air)	C50	ACC
Pin striping, lower body side (Not available with RPO Z26 Nova Rally equipment or RPO B74 wide wheel opening molding)	D85	
MODEL OPTIONS		
Cabriolet formal roof coupe equipment (See page 10 for content)	AB8	
Interior decor and convenience group (See page 11 for content)	ZJ3	
Nova Rally (see page 11 for content)	Z26	
POWER TEAMS		
Axle, Limited Slip	G80	
5.0 Litre 305 V8, 2-Barrel Carburetor	LG3	
Turbo-Fire 350 V8, 4-Barrel Carburetor	LM1	
4-Speed manual transmission (available only with LG3 engine)	MM4	
3-Speed Automatic	MX1	
POWER ASSISTS		
Brakes, power (option available only with L6 engine)	J50	
Steering, power: variable ratio	N41	
Power door lock system	AU3	
Power windows	A31	

AB8 CABRIOLET FORMAL ROOF, COUPE EQUIPMENT

MODEL AVAILABILITY

Nova (1XX27 and 1XY27 Coupes Only)

EQUIPMENT (Used in addition to or in place of standard equipment)

EXTERIOR

Plastic exterior filler panel insert forming formal side window opening.
Specific quarter window glass.
Landau style, fully padded vinyl top.
Landau molding treatment around periphery of vinyl Landau cover (right center section with bead at outer edges color keyed to vinyl top).
Bright rear window reveal molding (same as base).
"Cabriolet" script. Nameplate on sail panel.

INTERIOR

Quarter upper trim finishing panel above belt.
Air exhaust system in body lock pillar.

RPO ZJ3 AND RPO Z26 RALLY OPTION

ZJ3 INTERIOR DECOR AND CONVENIENCE GROUP

MODEL AVAILABILITY

Nova (1XX17-27-69), (Included with Custom models)

EQUIPMENT (used in addition to or in place of standard equipment)

INTERIOR

Right front door jamb switch, for dome lamp operation.
Glove box lamp.
Mirror 10" prismatic inside rear view.
Cigarette lighter.
Bright framing on instrument cluster carrier.

Z26 NOVA RALLY

MODEL AVAILABILITY

Nova (1XX17-27, 1XY27)

EQUIPMENT (Used in addition to or in place of standard equipment)

EXTERIOR

Body side and rear end panel striping in five available colors:
Black, White and Gold, Orange or Red
"NOVA RALLY" Nameplates on grille and fender side.
Rally wheels, 14 x 6 painted to match body color
(except with Gold striping, wheels match stripe color), with bright hub,
bright lug nuts and P06 trim ring.

AIR CONDITIONING

FOUR SEASON (RPO C60)

Integral air cooling and heater system. Manually controlled by two vertical levers on instrument control panel, plus 4-speed fan switch. Right lever operates compressor and air selector doors; and directs air to defroster outlets; left lever controls temperature of air flow from instrument panel outlets.

BASIC COMPONENTS

Control panel, evaporator, blower, condenser, receiver-dehydrator, refrigerant (freon) tank, air intake assembly and duct assembly for both systems.

EQUIPMENT (Used in addition to or in place of base equipment)

CHASSIS

Front and Rear Springs Heavy duty
Rear Axle Ratio - Refer Power Trains Section

POWER TRAINS

Fan Blade 7 blade
Fan Clutch Thermomodulated fluid coupling (*)
Crankshaft Pulley Single three groove pulley
Water Pump & Fan Pulley Single
Compressor & Crankshaft Belt One
Generator 55 Ampere
Radiator Heavier duty

(*) 305-V8, No fan clutch Thermomodulated fluid coupling.
Uses 7 Blade, Flex-Blade

DIMENSIONS AND WEIGHTS

INTERIOR DIMENSIONS	2, 3
LUGGAGE CAPACITY	3
EXTERIOR DIMENSIONS	4, 5
VEHICLE WEIGHTS	6
OPTIONAL EQUIPMENT WEIGHTS	6

INTERIOR DIMENSIONS

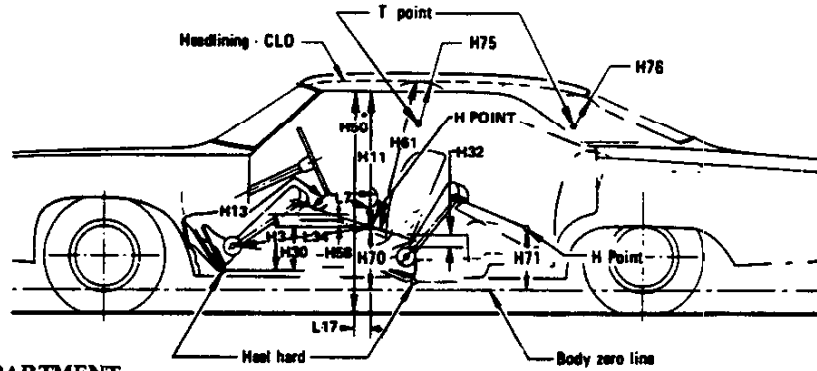

FRONT COMPARTMENT

CODE	DESCRIPTION	2-DOOR		
		HATCHBACK COUPE	COUPE	SEDAN
H-3	Seat cushion height		9.7	
H11	Entrance height	30.4		31.3
H13	Steering wheel thigh clearance		3.6	
H30	SgRP to heel point (chair height)		7.3	
H32	Seat cushion deflection		3.3	
H50	Upper body opening to ground	48.2		49.1
H58	H point rise		0.7	
H61	Effective headroom	38.2		39.1
H70	SgRP to body zero		12.8	
H75	Effective 'T' point headroom	38.4		39.3
W3	Shoulder room		56.6	
W5	Hip room		53.3	
L7	Steering wheel torso clearance		13.0	
L17	H point travel		4.7	
L34	Effective leg room		41.7	

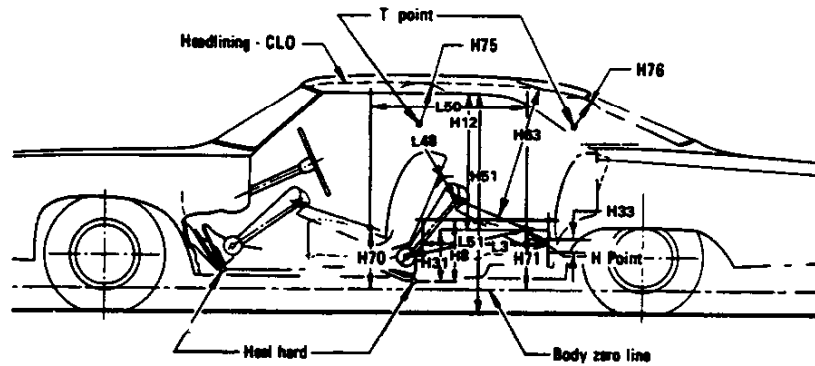

REAR COMPARTMENT

H8	Seat cushion height	13.2	13.9
H12	Entrance height	-	30.3
H31	SgRP to heel point (chair height)	10.5	11.6
H33	Seat cushion deflection	5.2	4.9
H51	Upper body opening to ground	-	48.1
H63	Effective headroom	36.7	37.1
H71	SgRP to body zero	12.6	13.7
H76	Effective 'T' point headroom	36.5	36.8
W4	Shoulder room	55.3	56.7
W6	Hip room	52.8	53.6
L3	Rear compartment room	24.2	25.4
L48	Knee clearance	-0.7	0.4
L50	SgRP couple distance	30.8	32.7
L51	Effective leg room	32.4	35.2

LUGGAGE COMPARTMENT

CODE	DESCRIPTION	2-DOOR HATCHBACK COUPE	2-DOOR COUPE	4-DOOR SEDAN
H195	Liftover height		27.4	
V1	Usable luggage capacity (cu.ft.) (a)	--	13.4	13.0

(a) Corporation "H" (shoe box) method of measurement is used.

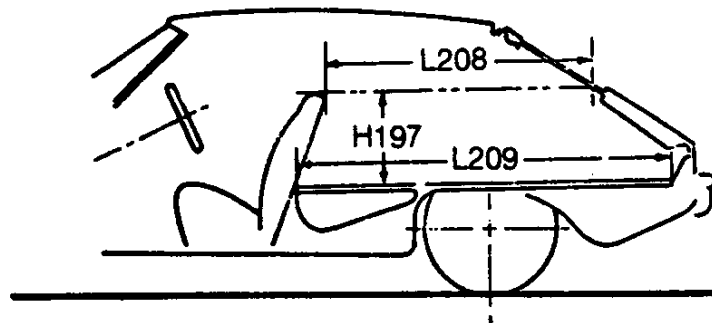

HATCHBACK CARGO SPACE

W4	Shoulder room - Rear	55.3
H197	Front seat back to load floor height	14.4
L208	Cargo length at - Front seat back height	49.7
L209	Cargo length at floor - Front seat	76.6
V3	Total Hatchback - cargo index Volume (cu. ft.)	29.2

EXTERIOR DIMENSIONS

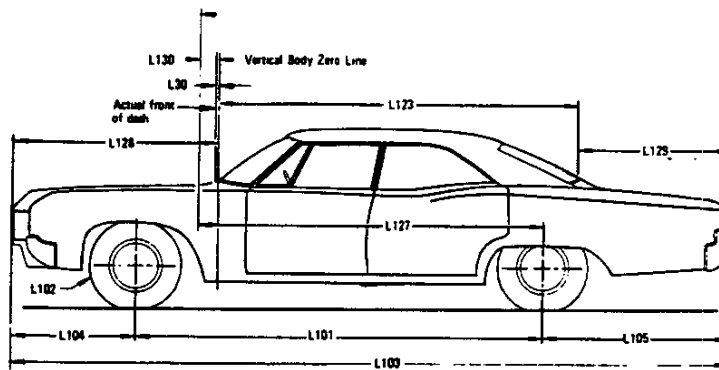

LENGTHS

CODE	DESCRIPTION	2-DOOR HATCHBACK COUPE	2-DOOR COUPE	4-DOOR SEDAN
L101	Wheelbase		111.0	
L102	Tire size (standard)		E78-14	
L103	Overall length		196.7	
L104	Overhang, front		33.9	
L105	Overhang, rear		51.8	
-	Overall length - less bumpers		186.7	
L123	Body upper structure length at car center line	101.0		96.8
L125	Body base grid plane to windshield cowl point		10.0	
L126	Front end length at centerline		56.4	
L127	Rear wheel centerline to body base grid line		93.0	
L128	Front wheel centerline to body base grid line		-18.0	
L129	Rear end length at centerline	28.1		32.3
L130	Front of dash to body base grid		0.5	

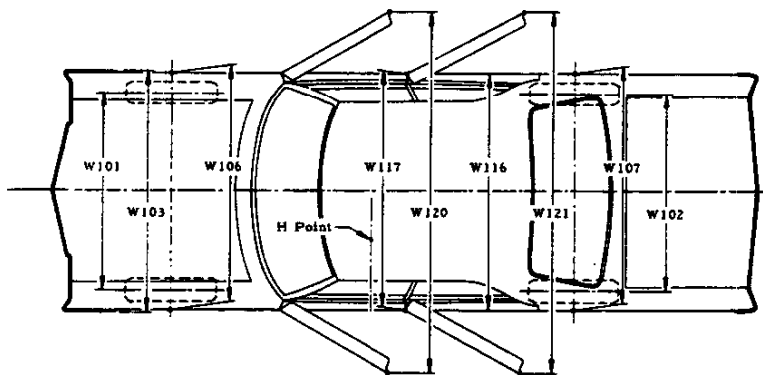

WIDTHS

CODE	DESCRIPTION	2-DOOR HATCHBACK COUPE	2-DOOR COUPE	4-DOOR SEDAN
W101	Tread-Front		61.3	
W102	Tread-rear		59.0	
W103	Maximum overall width of car		72.2	
W106	Front fender overall width		72.2	
W107	Rear fender overall width		70.5	
W116	Maximum overall width of body		72.2	
W117	Body width at SgRP - front	---		70.7
W120	Overall car width, front doors open	144.8		127.7
W121	Overall car width, rear doors open	---		126.5

*Primary Dimensions are millimetres unless otherwise shown.

EXTERIOR DIMENSIONS

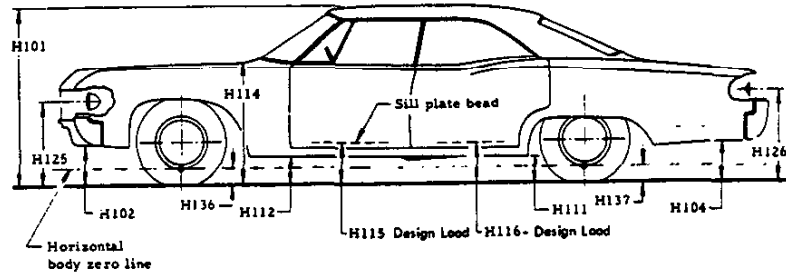

HEIGHTS

CODE	DESCRIPTION	2-DOOR HATCHBACK COUPE	2-DOOR COUPE	4-DOOR SEDAN
H101	Overall height (design)	52.7		53.6
H102	Front bumper to ground		12.2	
H104	Rear bumper to ground		11.0	
H111	Rocker panel to ground - rear		7.2	
H112	Rocker panel to ground - front		8.1	
H114	Hood at rear to ground		36.2	
H115	Step height - front (design)		12.6	
H116	Step height - rear (design)		12.3	
H125	Headlamp to ground		25.3	
H126	Tail lamp to ground		23.8	
H136	Body O line to ground - front		5.1	
H137	Body O line to ground - rear		4.3	

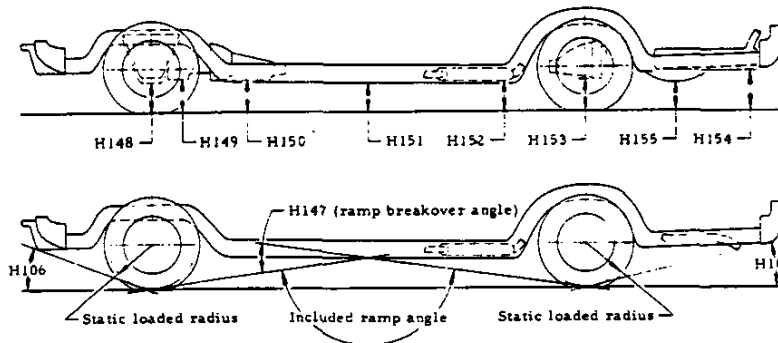

CLEARANCES

H106	Angle of approach (degrees)	23°39'
H107	Angle of departure (degrees)	13°13'
H147	Ramp breakover angle (degrees)	13°24'
H148	Front suspension to ground	5.7
H149	Oil pan to ground	4.8
H150	Flywheel housing to ground	5.1
H151	Frame to ground	4.6
H152	Exhaust system to ground	4.8
H153	Rear axle to ground	6.6
H154	Fuel tank to ground	6.9
H155	Tire well to ground	14.5
H156	Minimum ground clearance	4.6 (a)

(a) Frame to ground.

VEHICLE WEIGHTS

NOVA

MODEL TYPE			SHIPPING WEIGHT			CURB WEIGHT		
MODEL DESIGNATION	BASE ENGINE	VEHICLE TYPE	Front	Rear	Total	Front	Rear	Total
1XX17	250 Cu.In. L6	2-Door Hatchback Coupe	1770	1501	3271	1754	1628	3382
1XX27	250 Cu.In. L6	2-Door Coupe	1768	1384	3152	1752	1510	3262
1XX69	250 Cu.In. L6	4-Door Sedan	1759	1431	3190	1742	1558	3300
1XY27	250 Cu.In. L6	2-Door Coupe	1795	1402	3197	1778	1529	3307
1XY69	250 Cu.In. L6	4-Door Sedan	1813	1419	3232	1797	1545	3342

SHIPPING WEIGHT: Weight of basic vehicle with regular equipment, including grease, oil and (3) gallons of gasoline, and engine coolant to capacity.

CURB WEIGHT: Shipping weight plus gasoline to capacity.

For total shipping, and curb, weights of vehicles equipped with the following options, add to, or deduct from, the base vehicle weight (lbs.).

OPTIONAL EQUIPMENT

RPO	OPTION	WITH	WEIGHT
AU3	Electric Door Locks	2-Door Models	+ 7
		4-Door Models	+ 13
A31	Power Windows	2-Door Models	+ 10
		4-Door Models	+ 26
B37	Floor Mats, Front and Rear		+ 8
C09	Exterior Soft Roof Cover		+ 6
C50	Defogger, Rear Window		+ 3
C60	Air Conditioning	With L6 Engine	+ 64
		With V8 Engines	+ 86
D55	Floor Console	3-Speed Transmission	+ 4
		4-Speed Transmission	+ 4
		Automatic Transmission	+ 9
F41	Spec. Perf. Front and Rear Suspension		+ 25
F40	Heavy Duty Front and Rear Suspension		+ 14
J50	Power Brakes		+ 9
N41	Power Steering	L6 Engine	+ 30
		V8 Engine	+ 28
UA1	Heavy Duty Battery	With L6 Engine	+ 15
		With V8 Engine	+ 15
UM1	Radio AM Pushbutton and Stereo Tape		+ 11
UM2	Radio AM/FM Pushbutton and Stereo Tape		+ 11
UN3	Radio AM/FM Stereo with Cassette Player		+ 7
UY8	Radio AM/FM Stereo with Clock and Digital Display		+ 8
U58	Radio AM/FM Stereo		+ 8
U63	Radio AM Pushbutton		+ 5
U69	Radio AM/FM Pushbutton		+ 7
Z37	Special Wheel, Hub Cap and Trim Ring	With 1XX17	+ 14
		With 1XX-1XY27-69	+ 18
Base	250 Cu. In. 6 Cyl. Engine	With Automatic Transmission	+ 23
LG3	305 Cu. In. V8 Engine	With 4-Speed Transmission	+142
		With Automatic Transmission	+153
LM1	350 Cu. In. V8 Engine	With Automatic Transmission	+152

BODY

EXTERIOR PAINT PROCESS	2
EXTERIOR-INTERIOR COLORS AND VINYL ROOF COMBINATIONS	3
EXTERIOR-INTERIOR COLORS	4 & 5
EXTERIOR-TWO-TONE COLORS COMBINATIONS (RPO D99)	6
BODY CONSTRUCTION AND GLASS AREA	7

EXTERIOR PAINT PROCESS

1. **RUSTPROOFING.** Assembled car bodies are chemically sprayed to clean and etch the metal surfaces for corrosion resistance and paint adhesion. Unassembled sheet metal parts follow the same process.
- * 2. **BODY PRIMERS.** Four corrosion resistant primers, specially formulated, are hand sprayed on the body in areas where rust might develop. Lower areas considered especially vulnerable are coated with another rust inhibiting compound.
- * 3. **SHEET METAL PRIMER** is applied to all outside and inside surfaces of front fenders and hoods. The parts are mechanically dipped or flow-coated to insure coating in all seams and secluded areas, and baked at 390 degrees F. for 30 minutes. A coat of sealer is then applied by hand spray to all surfaces requiring lacquer.
4. **FLASH PRIMER AND PRIMER-SURFACER COATS.** An air-dry flash primer coat is hand sprayed on surfaces below the body belt line. Then a gray primer-surfacer coat is hand sprayed on all outside surfaces of the body and oven baked for 45 minutes at 285 degrees F.
5. **INITIAL SANDING.** Power wet sanding, followed by hand sanding is done on all body surfaces requiring lacquering. This insures a smooth surface for the lacquer finish. To remove the water, the body is wiped and run through an infra-red oven.
6. **LACQUERING.** Three coats of acrylic lacquer are applied on the exterior surfaces of the body and sheet metal parts to build up a finish of the required thickness for each color.
7. **INITIAL BAKING.** To harden the paint for two tone, the body and sheet metal parts are baked for approximately 10 minutes at 200 degrees F.
8. **FINAL BAKING.** To assure a durable, hard, high luster finish the lacquer is baked for 30 minutes at 325 degrees F. Reheating the lacquer permits paint film to soften, allowing surface blemishes to disappear during the thermo-reflow process.
9. **UNDERCOATING.** To block out road noise, an asbestos fiber sound deadener with asphalt base is sprayed inside the wheel housings and on the bottom of the underbody at designated areas.
10. **PAINT REPAIR AND PROTECTION.** Mars, nicks, or scratches that occur during final assembly are corrected at the factory before shipment. When required, light "slush" polishing brings painted surfaces to a high luster finish. Wax is applied to all horizontal surfaces of each vehicle and polished out for protection during shipment. The wax contains no silicones, thus eliminating any paint contamination problem.

* Plants employing the Elpo Process (see Monza for description) preclude need for these priming steps.

EXTERIOR-INTERIOR COLORS

EXTERIOR COLORS – VINYL ROOF COMBINATIONS

VINYL TOP COVER (Material - Levant Grain)	EXTERIOR COLOR AVAILABILITY
Silver (Met.)	Silver (Met.) 15
	Black 19
	Bright Blue (Met.) 24
	Dark Blue (Met.) 29
	Carmine (Met.) 77
Black	All Available Colors Except 69
White	All Available Colors
Light Blue (Met.)	White 11
	Black 19
	Light Blue (Met.) 22
	Dark Blue (Met.) 29
Beige	White 11
	Black 19
	Beige 61
	Camel (Met.) 63
	Dark Brown (Met.) 69
Carmine, Dark (Met.)	Carmine (Met.) 77
Light Green (Met.)	Light Green 40
	Medium Green (Met.) 44

EXTERIOR-INTERIOR COLORS

1979 CHEVROLET NOVA 'X' INTERIOR COLOR COMBINATIONS

MODEL	Seat Type	INTERIOR TRIM									
		Black	Light Blue		Camel Tan		Carmine		White		
		(19X)	(24X)	(24X)	(62X)	(62X)	(74X)	(74X)	(19X)	(24X)	(74X)
	Vinyl	Cloth	Vinyl	Cloth	Vinyl	Cloth	Vinyl	Vinyl /Black	Vinyl /Blue	Vinyl /Carmine	
Standard - 1XX00 Hatchback (17)	(A52) Bench	19R		24R		62R		74R			
Coupe (27) *	(A52) Bench	19R	24B	24R	62B	62R		74R			
Sedan (69)	(A52) Bench	19R	24B	24R	62B	62R		74R			
Custom - 1XY00	(A52) Bench		24D		62D	62N	74D	74N	11N	11N	11N
Coupe (27) *	(A51) Bucket					62N		74N			
Sedan (69)	(A52) Bench		24D		62D	62N	74D	74N			

CLOTH AND VINYL USAGE

R-Plisse vinyl

B-Bordeau, 807 WC, woven sport cloth

N-Wallaby vinyl

D-Edinburgh, 739 WC, woven sport cloth

* The 1XX27 requires a Big Four Option Number in addition to the trim combination number. The Big Four Module consists of the instrument panel, carpet, cowl kick panel, and package shelf. Module numbers are shown in parenthesis at the top of each column. Examples: Carmine-74N + 74X, White with Blue Big Four-11N + 24X.

EXTERIOR-INTERIOR COLORS

1979 "NOVA RALLY" STRIPE PKG. (RPO Z26)

EXTERIOR		INTERIOR TRIM						
		BLACK	LT. BLUE	CAMEL TAN	CARMINE	WHITE		
						w/Black	w/Blue	w/Carmine
STRIPE PACKAGE COLOR SCHEME								
White	11	Black	Black	Gold	Red	Black	Black	Red
Silver Met.	15	Black	Black	—	Red	Black	—	—
Black	19	Red	White	Gold	Red	White	—	Red
Lt. Blue Met.	22	Black	White	—	—	Black	White	—
Brt. Blue Met.	24	Black	White	—	—	Black	White	—
Dk. Blue Met.	29	Gold	White	Gold	—	White	White	—
Light Green	40	Black	—	Gold	—	White	—	—
Med. Green Met.	44	Black	—	Gold	—	White	—	—
Bright Yellow	51	Black	—	Black	—	Black	—	—
Beige	61	Orange	—	Gold	—	Gold	—	—
Camel Met.	63	Orange	—	Gold	—	White	—	—
Dk. Brown Met.	69	Orange	—	Gold	—	White	—	—
Red	75	Orange	—	Orange	White	White	—	White
Carmine Met.	77	Orange	—	Orange	Red	White	—	White

COLOR IDENTIFICATION

Stripe & Lettering	Rally Wheel Paint*
11A White WMH 3967	Body Color
19A Black WMH 848	Body Color
54A Gold WMH 8063	Gold WE 7062
75A Red WMH 7032	Body Color
80A Orange WMH 8093	Body Color

- NOTES: 1. *Rally Wheels to match Body color except with Gold stripe package which uses a Specific Wheel Color to match Stripe.
2. These are the only combinations available —
NO COLOR OVERRIDES ARE ALLOWED!

EXTERIOR-INTERIOR COLORS

1979 NOVA BODY SIDE ACCENT STRIPE (RPO D85) BODY SIDE MOLDING EQUIPMENT (RPO BW2)

RPO BW2 – BODY SIDE MOLDING EQUIPMENT*

RPO D85 – BODY SIDE LOWER ACCENT STRIPE*

MOLDING IDENTIFICATION		
15Q	Silver Met.	WPV 7022
22Q	Lt. Blue Met.	WPV 4964
40Q	Light Green	WPV 8028
61Q	Beige	WPV 8030
79Q	Dk. Carmine Met.	WPV 7072

STRIPE IDENTIFICATION (PAINT)		
11A	White	WSA 3967
13A	Silver	WSA 4609
19A	Black	WSA 848
27A	Blue	WSA 4673
49A	Green	WSA 4922
54A	Gold	WSA 4326
75A	Red	WSA 4330
80A	Orange	WSA 4909

* NOTE: For color combination applications, see Dealer Order Guide.

1979 NOVA REGULAR TWO-TONE PAINT COMBINATIONS (RPO D99)

EXTERIOR COLORS			
LOWER		UPPER	
Bright Blue Met.	24L	White	11U
Med. Green Met.	44L	White	11U
Camel Met.	63L	Beige	61U
Dk. Brown Met.	69L	Beige	61U
Red	75L	White	11U
Carmine Met.	77L	White	11U

BODY CONSTRUCTION AND GLASS AREA

GENERAL

Type Separate partial front frame and bolt-on front end sheet metal, with protective inner fender skirts. Roof, doors, front and rear lids are of double-panel construction.

DOORS AND LOCKS

Door construction Double panel, hinged at front
 Door handles Exterior, push-button fork type latches. Inside push-button locks and 2-position free-wheeling inside door handles on rear doors of 4-door models.

HOOD AND TRUNK LID

Type Counterbalanced, with strap type hinges actuating torsion rods on trunk lid and spring loaded toggle-type hinges on rear of hood.
 Hood release External

VENTILATION

High level air intake for passenger compartment . . with double wall plenum chamber, providing washing and air drying of rocker panels for corrosion resistance. Air and water travel through rocker panels and drain at ends of rocker inner panels.

SEAT CONSTRUCTION

Type
 All seat cushions and backrests . . . Formed polyfoam

WINDSHIELD WIPERS

Type Dual 2-speed electric
 Linkage Parallel acting

HEADLIGHTS

Type Single - Rectangular Power Beam units

SPARE TIRE AND TOOLS

Location Sedan and coupe, horizontal - center forward area of trunk floor. Tools consist of bumper jack and socket type "L" wrench stored on rear quarter panel (jack base stored with spare tire).

Hatchback coupe, spare tire horizontal - under cargo floor. Bumper jack - under hinged cargo load floor.

BODY GLASS VISIBILITY AREA

	MODELS		
	17	27	69
Windshield	1209.3		1282.1
Front Door Window	988.9		762.5
Rear Door Window	--		608.8
Rear Quarter Window	564.6	564.6 (Formal 361.5)	211.6
Back Window	1158.6	1392.1	1092.1
Total Area (Sq. In.)	3921.4	4154.9 (3951.8)	3957.1

All window glass curved safety solid plate except curved laminated safety plate windshield.

T

CHASSIS

FRAME AND FRONT SUSPENSION	2-3
STEERING, DRIVELINE, WHEELS AND TIRES	4
REAR AXLE AND SUSPENSION	5
BRAKES	6
BULBS AND LAMPS	7
FUSES AND CIRCUIT BREAKERS	8

FRAME AND FRONT SUSPENSION

FRAME

Description Extended rail front partial frame of deep sectioned double-channelled side members joined by three flanged hat-section crossmembers.

Body Mounting

Number and type 3 each side double cushion

FRONT SUSPENSION

Description Independent, SLA type with coil springs, center mounted shock absorbers and spherical joint steering knuckle pivots

Wheel travel (design)

Total 6.90

Jounce 2.34

Rebound 4.56

Wheel to spring travel ratio 2.02:1

CONTROL ARMS

Description Reinforced steel stamping with pre-loaded, steel encased, rubber bushings at pivots.

STEERING KNUCKLES

Description Nodular iron with integral steering knuckle arm.

Spindle diameters

Inner bearing 1.2493-1.2498

Outer bearing8441

Spindle thread size 3/4-20 NEF-3 (modified)

Wheel bearings

Type Taper roller; inner and outer

SPHERICAL JOINTS

Type Ball stud

Upper Compression

Lower Compression

Bearing surfaces

Upper Teflon-cotton composite on phenolic

Lower Sintered iron

SHOCK ABSORBERS

Type Direct, double acting, hydraulic

Piston diameter 1.00

STABILIZER BAR

Type Link

Material HR steel

Diameter875, .9375 or 1.00 contingent as to how vehicle is equipped

FRONT WHEEL ALIGNMENT (CURB)

Camber (degrees)

Manual steering P3/4 ± 3/4

Power Steering P3/4 ± 3/4

Caster (degrees)

Manual Steering N1 ± 1

Power Steering P1 ± 1

Toe-in (total) 1/16 ± 1/8

Steering axis inclination (degrees) 10° @ 0.75° camber

GENERAL SUSPENSION PROVISIONS

Car leveling Front stabilizer bar

Anti-dive control Angle of front upper control arm

Anti-squat control Rear suspension geometry

FRAME AND FRONT SUSPENSION

FRONT SPRINGS

Selected from a family of springs by Electronic Data Processing which identifies the correct springs for the weight of the vehicle including optional equipment ordered by the customer.

FRONT SPRING SPECIFICATIONS

Engine Application	Part Number	Assy. Code	Cut-Off Length	Wire Dia.	Total Coils	Deflection Rate (lbs./inch)	HEIGHTS	
							Free	Working (In. @ Lbs.)
L-6	334444	KB	118.38	.665	7.79	400	15.10	11.0 @ 1630
	334445	KF	118.41	.665	7.79	400	15.30	11.0 @ 1710
	6272862	LA	118.44	.665	7.79	400	15.50	11.0 @ 1790
	6262425	DH	126.23	.680	8.29	400	15.70	11.0 @ 1870
	6262426	DJ	126.26	.680	8.29	400	15.90	11.0 @ 1950
	6262427	DK	129.40	.686	8.49	400	16.10	11.0 @ 2030
V-8	346996	HM	116.07	.617	7.70	300	16.46	11.0 @ 1620
	3996361	AE	116.10	.617	7.70	300	16.66	11.0 @ 1680
	354160	EV	114.83	.626	7.64	330	16.41	11.0 @ 1775
	354161	HI	114.86	.626	7.64	330	16.61	11.0 @ 1840
	334447	KT	128.96	.668	8.49	365	16.23	11.0 @ 1900
	334450	KU	132.09	.674	8.69	365	16.44	11.0 @ 1975
	334451	KV	133.68	.677	8.79	365	16.64	11.0 @ 2050
	6262428	DL	130.99	.688	8.59	400	16.30	11.0 @ 2110

STEERING, DRIVELINE, WHEELS AND TIRES

STEERING

Wheel	
Type	Round with center shroud
Diameter	15.0
Column Energy absorbing – mast jacket, shifter tube and steering shaft designed to collapse under various front impact conditions.	
Gear – Manual (standard); Power (optional)	
Gear Type	
Manual (Standard)	Recirculating ball nut
Power (Optional)	Integral, recirculating ball nut with hydraulic pressure provided from a vane type pump.
Ratios, Gear	
Manual	24.0:1
Power	16.0:1 on center to 13.0:1
Ratios, Overall	
Manual	26.2:1
Power	15.07:1 on center to 11.31:1
Number of wheel turns, lock to lock	
Manual	4.99
Power	2.42
Linkage Parallelogram, rear of wheels, 2 tie rods	
Turning diameter	
Outside front, wall to wall	39.9
Outside front, curb to curb	38.1
Inside rear, wall to wall	11.77
Inside rear, curb to curb	10.89
Outside wheel angle with inside wheel @ 20°	
Manual	18.85
Power	18.65

DRIVELINE

Type	Straight tube
Number used	One
Diameter (OD)	2.75
Wall Thickness	0.065
Length (C/L of U-joints)	
4.1 Litre L6 (7.5" Ring gear)	53.14
4.1 Litre L6 (8.5" Ring gear), 5.0L & 5.7L V8	51.78
Universal Joints	
Type	Cross
Number used	Two
Bearings	Prepacked, anti-friction

WHEELS

Type	Short, spoke spider
Size	
Base equipment	14 x 6
Rally type, optional	14 x 6
Rally type, optional	14 x 7
Offset	
Base equipment	0.50
Rally type, optional (14 x 6)	0.50
Rally type, optional (14 x 7)	0.34
Attachment to Hub	
Type	5 hex nuts
Thread size	7/16-20 UNF 2-B
Bolt circle diameter	4.75

TIRE, STANDARD EQUIPMENT

Size	E78-14
Type	Bias belted
Sidewall	
Base	Blackwall
Optional	White stripe
Static loaded radius	12.04
Loaded rev/mi @ 45 mph	796
Capacity @ 24 psi	1190

TIRES, OPTIONAL EQUIPMENT

Size	FR78-14
Type	Steel belted radial
Sidewall	
Base	Blackwall
Optional	White stripe and White letter
Static Loaded Radius	11.60
Loaded Rev/mi @ 45 mph	797
Capacity @ 24 psi	1280

SPARE TIRE, STOWAWAY

Base	Hatchback coupe
Optional	Remainder models
Wheel Size	14 x 5

REAR AXLE AND SUSPENSION

REAR AXLE

Description Three piece housing includes integral cast iron differential carrier and housing with two pressed-in and welded steel tubes. Semi-floating axle shafts. Differential carrier contains hypoid overhung pinion and ring gear. Drive pinion supported by two taper roller bearings.

Drive pinion vertical offset 1.75

Hypoid gear PD
 250 L6 7.50 & 8.50
 305 & 350 V8 8.50

Pinion bearing adjustment Shim

Lubricant
 Type GL-5 Gear lubricant
 Viscosity 80W or 80W-90
 Capacity (pts)
 7.50 in. ring gear 3.25
 8.50 in. ring gear 4.00

AXLE SHAFT

Description Forged and hardened steel with integral drive flange

Wheel bearings Single row cylindrical roller, one per wheel

Oil seal Steel encased, spring loaded synthetic rubber

RING AND PINION GEAR AND TOOTH COMBINATIONS

(See Power Train Section for application)

2.41:1 17, 41
 2.56:1 16, 41
 2.73:1 15, 41
 3.08:1 13, 40

LIMITED SLIP DIFFERENTIAL (See Power Trains)

Type Two pinion with single disc clutch

REAR SUSPENSION

Description Hotchkiss;
 2 semi-elliptical multiple leaf springs

Wheel travel (design)
 Total L.H.-7.84; R.H.-8.24
 Jounce 2.14
 Rebound L.H.-5.70; R.H.-6.10
 Wheel to spring, travel ratio 1:1

SHOCK ABSORBERS

Type Direct, double acting, hydraulic
 Piston diameter 1.00

REAR SPRINGS

Selected from a family of leaf springs by Electronic Data Processing which identifies the correct springs for the weight of the vehicle including optional equipment ordered by the customer.

REAR SPRING SPECIFICATIONS

Engine Application	Part Number	Assy. Code	Length	Width	Number of Leaves	Mounting Insulation	Deflection Rate (Lbs./In.)	Load @ .52 Spring Camber (Lbs.)
L-6	362104	NBC	56.0	2.50	Six	Rubber bushed at shackle and hanger	95	560
	362105	NBD			Seven		95	608
	378552	NCY			Seven		95	658
	378553	NCZ			Seven		95	708
V-8	362104	NBC	56.0	2.50	Six		95	560
	362105	NBD			Seven		95	608
	362103	NBB			Six		120	660
	362102	NBA			Six		120	715
	362109	NBJ			Six	120	765	

BRAKES

General	Type	Front - Disc; Rear - Drum	
	System	Manual - Standard	Power - Optional (*)
		Dual circuit hydraulic system with warning light and self-adjusting features - metering and proportioning valves provide balance between front and rear wheels.	
Front Brakes	Type	Disc - single piston floating caliper	
	Material	Cast iron - vented	
	Diameter and Width	11.0 x 1.03	
	Lining material	Compression molded asbestos composition	
	Method of attachment	Riveted	
	Lining size (length x width x thickness)	Inboard	5.40 x 1.92 x 0.46
		Outboard	5.40 x 1.92 x 0.46
	Lining area (sq. in.)	38.76	
	Effective area (sq. in.)	36.8	
	Swept area (sq. in.)	210.4	
Piston diameter	2.94		
Rear Brakes	Type	Drum - Composite, web cast into rim, finned construction	
	Material	Web - HR steel, Rim - cast alloy iron	
	Diameter and Width	9.5 x 2.0	
	Lining material	Molded asbestos composition	
	Method of attachment	Riveted	
	Lining size (length x width x thickness)	Primary	7.30 x 2.00 x 0.23
		Secondary	9.46 x 2.00 x 0.30
	Lining area (sq. in.)	67.04	
	Effective area (sq. in.)	63.72	
	Swept area (sq. in.)	116.06	
Piston diameter	.938		
Apply System	Master cylinder diameter	1.00	1.125
	Piston travel	1.253	1.408
	Pedal travel	7.38	5.44
	Pedal ratio	6.22:1	3.54:1
	Line pressure @ 100 lb. pedal load	550	900
Parking Brake	Type	Mechanical: pull rods and cables operate rear service brakes; parking brake 'ON' warning lamp provided.	
	Control	Pendulum foot pedal; released by "T" handle located on instrument panel to left of steering wheel	
	Total effective area	63.72	

(*) - Standard with V8 Engine Equipped Vehicles.

BULBS AND LAMPS

BULBS AND LAMPS	NUMBER REQUIRED AND TRADE NUMBER	CANDLE POWER PER LAMP
Backing Lamps	2-1156	32
Parking brake alarm indicator	1-194	2
Courtesy (instrument panel)	2-631	6
Direction signal indicators	2-168	2
Dome	1-561	12
Generator indicator	1-194	2
Glove compartment	1-1891	2
Headlamp	2-6052	High beam
		Low beam
Headlamp hi-beam indicator	1-168	2
Heater or A/C control	1-194	2
Instrument cluster	5-168	3
License plate	1-194	2
Luggage compartment	1-1003	15
Oil pressure indicator	1-194	2
Parking Park	2-1157	3
		Turn
Radio - AM	1-1893	2
Radio - AM/FM	1-1893	1
Radio - UMI & UM2	1-1893	2
		Ind.
Radio - US8	1-1893	2
		Indicator
Indicator	1-DS410	Led (a)
Seat belt warning indicator	1-168	2
Side Marker - Front	2-194	2
Side Marker - Rear	2-194	2
Tail	2-1157	3
		Stop and turn
Temperature indicator	1-194	2
Underhood lamp	1-93	15
W/S Washer & light switch indicator	1-194	2

(a) Light emitting diode.

FUSES AND CIRCUIT BREAKERS

CIRCUIT	TYPE OF PROTECTION	LOCATION AND CIRCUIT *
Air conditioning	30 amp fuse	In line
	20 amp fuse	Fuse panel (d)
Back-up lamps	20 amp fuse	Fuse panel (d)
Brake alarm	10 amp fuse	Fuse panel (b)
Cigarette lighter	20 amp fuse	Fuse panel (c)
Clock	20 amp fuse	Fuse panel (c)
Courtesy lamps	20 amp fuse	Fuse panel (c)
Defogging unit	10 amp fuse	Fuse panel (b)
Defogging, electric rear	10 amp fuse	Fuse panel (b)
Direction signal indicator lamps	10 amp fuse	Fuse panel (b)
Dome lamp	20 amp fuse	Fuse panel (c)
Door Lock	30 amp CB	In line
Fuel economy light	10 amp fuse	Fuse panel (b)
Fuel gauge	10 amp fuse	Fuse panel (b)
Generator indicator lamp	10 amp fuse	Fuse panel (b)
Glove compartment lamp	20 amp fuse	Fuse panel (c)
Headlamps	Circuit breaker	Light switch
Headlamp hi-beam indicator lamp	Circuit breaker	Light switch
Headlight buzzer	10 amp fuse	Fuse panel (b)
Heater	20 amp fuse	Fuse panel (d)
Heater control lamp	4 amp fuse	Fuse panel (a)
Instrument cluster lamps	4 amp fuse	Fuse panel (a)
Key wiring buzzer	20 amp fuse	Fuse panel (c)
License lamp	20 amp fuse	Fuse panel (h)
Luggage compartment lamp	20 amp fuse	Fuse panel (c)
Oil pressure indicator lamp	10 amp fuse	Fuse panel (b)
Parking lamps	20 amp fuse	Fuse panel (h)
Parking brake alarm lamp	10 amp fuse	Fuse panel (b)
Power window motor	20 amp fuse	Fuse panel (d)
Radio	10 amp fuse	Fuse panel
Radio dial lamp	4 amp fuse	Fuse panel (a)
Seat belt warning buzzer	10 amp fuse	Fuse panel (b)
Seat belt warning lamp	10 amp fuse	Fuse panel (b)
Side Marker lamp - Front & Rear	20 amp fuse	Fuse panel (d)
Speed cruise control	10 amp fuse	Fuse panel (b)
Tail lamps	20 amp fuse	Fuse panel (h)
Idle stop solenoid	10 amp fuse	Fuse panel (g)
Temperature indicator lamp	10 amp fuse	Fuse panel (b)
Temperature gage	10 amp fuse	Fuse panel (b)
Traffic hazard indicator	20 amp fuse	Fuse panel (a)
Stop and turn lamps	20 amp fuse	Fuse panel (f)
Underhood lamp	20 amp fuse	Fuse panel (c)
Windshield wiper, two-speed	25 amp fuse	Fuse panel
Windshield washer	4 amp fuse	Fuse panel (a)
Windshield washer pump	20 amp fuse	Fuse panel (d)
Windshield pulse wiper system	10 amp fuse	Fuse panel (g)

* Letter suffix indicates same circuit

POWER TRAINS

POWER TEAM COMBINATIONS	2
POWER TEAM MULTIPLICATION FACTORS	3
ENGINE DATA AND RATINGS	4
ENGINE SPEED AND PISTON TRAVEL	5
VEHICLE PERFORMANCE FACTORS	6
PRINCIPAL COMPONENTS	7
FUEL SYSTEM	13
EXHAUST SYSTEM	14
EMISSION CONTROL EQUIPMENT	15
LUBRICATION SYSTEM	16
COOLING SYSTEM	17
ELECTRICAL SYSTEM	18
CLUTCHES	19
THREE AND FOUR SPEED TRANSMISSIONS	19
THREE-SPEED AUTOMATIC TRANSMISSION	20

POWER TEAM COMBINATIONS

ENGINE	TRANSMISSION	MODEL APPLICATION	AXLE RATIOS *			RING GEAR	LW. CLASS
			ALL STATES		WITH ALT. RPO NA6		
			BASE	OPT.			
4.1 Litre L-6 (250 CID) - (L22) Base - all states	3-Speed (3.50:1 low) (a)	All Models	2.56:1	-	-	7.50 or (c) 8.50	1816
	3-Speed Automatic		2.56 2.73:1 (d)				
5.0 Litre V-8 (305 CID) - (LG3) Optional - all states	4-Speed (2.85:1 low) (a)	All Models	3.08:1	-	-	8.50	1816
	3-Speed Automatic		2.41:1				
5.7 Litre V-8 (350 CID) - (LM1) Optional - (b)	3-Speed Automatic	All Models	2.41:1 (e)	3.08:1	3.08:1	8.50	1816

* Limited slip axles available optionally for all ratios shown;
same ratios available with Air Conditioning.

(a) Not available in California.

(b) States above 4000 Feet and California.

(c) To be used optionally.

(d) California only.

(e) California only.

MULTIPLICATION FACTORS

WITH MANUAL TRANSMISSIONS

ENGINE	CARBURETION	TRANSMISSION	TOTAL GEAR REDUCTION*					AXLE RATIO
			1st	2nd	3rd	4th	Rev	
4.1 Litre L-6 Standard	Single Barrel	3-Speed	8.96	4.84	2.56	-	9.27	2.56
5.0 Litre V-8 RPO LG3	2-Barrel	4-Speed	8.78	6.22	4.16	3.08	8.78	3.08

WITH AUTOMATIC TRANSMISSIONS

ENGINE	TRANSMISSION	SELECTOR POSITION	TOTAL TORQUE MULTIPLICATION*	AXLE RATIO
4.1 Litre L-6 Standard	3-Speed Automatic	Drive	12.90:1 - 2.56:1	2.56
		Second	12.90:1 - 3.89:1	
		Low	12.90:1 - 6.45:1	
		Reverse	9.88:1 - 4.94:1	
4.1 Litre L-6 Standard	3-Speed Automatic	Drive	13.76:1 - 2.73:1	2.73:1
		Second	13.76:1 - 4.15:1	
		Low	13.76:1 - 6.88:1	
		Reverse	10.59:1 - 5.30:1	
5.0 Litre V-8 RPO LG3	3-Speed Automatic	Drive	12.15:1 - 2.41:1	2.41:1
		Second	12.15:1 - 3.66:1	
		Low	12.15:1 - 6.07:1	
		Reverse	9.35:1 - 4.68:1	
		Drive	15.52:1 - 3.08:1	3.08:1
		Second	15.52:1 - 4.68:1	
		Low	15.52:1 - 7.76:1	
		Reverse	11.95:1 - 5.97:1	
5.7 Litre V-8 RPO LM1	3-Speed Automatic	Drive	12.15:1 - 2.41:1	2.41:1
		Second	12.15:1 - 3.66:1	
		Low	12.15:1 - 6.07:1	
		Reverse	9.35:1 - 4.68:1	
		Drive	15.52:1 - 3.08:1	3.08:1
		Second	15.52:1 - 4.68:1	
		Low	15.52:1 - 7.76:1	
		Reverse	11.95:1 - 5.97:1	

ENGINE DATA AND RATINGS

GENERAL DATA

Engine Type	L-6 OHV		V-8 OHV	
Piston Displacement-Litres (CID)	4.1 (250)		5.0 (305)	5.7 (350)
Availability	Base (L22)		LG3	LM1
Number of Cylinders	Six		Eight	
Bore (nominal)	3.875		3.736	4.00
Stroke (nominal)	3.53		3.48	
Compression Ratio	8.0:1 (8.2:1)		8.4:1	8.2:1
Taxable (SAE) Horsepower	36.0		44.7	51.2
Firing Order	1-5-3-6-2-4		1-8-4-3-6-5-7-2	
Idling Speed	Manual (in neutral)	800	600	--
	Turbo Hydra-matic (in drive)	550 (600)	500	600
Compress. Press. (PSI) @ Cranking Speed, Engine Hot	130		160	
Power Plant Mounting	Front	Two, preloaded captive cushion type		
	Rear	One, shear type		
Measurements	Fan to rear of engine block	35.78	31.55	
	Top of air cleaner to bottom of oil pan	27.22	29.60	28.52
	Width - including air cleaner (a)	17.76	28.53	

(a) L6 engine - (oil filter to exhaust manifold); V8 engines (across exhaust manifold)
Data in brackets () pertains to California.

ADVERTISED ENGINE RATING

Engine Designation	Availability	Carburetor	Federal		Calif.	Net Brake HP @ RPM	Net Torque @ RPM (lb. ft.)
			Below 4000 Ft.	Above 4000 Ft.			
4.1 Litre L-6	RPO L22	Single Bbl.	X			115 @ 3800	200 @ 1600
					X	90 @ 3600	175 @ 1600
5.0 Litre V-8	RPO LG3	Two Bbl.	X			130 @ 3200	245 @ 2000
					X	125 @ 3200	235 @ 2000
5.7 Litre V-8	RPO LM1	Four Bbl.		X	X	165 @ 3800	260 @ 2400

ENGINE SPEED AND PISTON TRAVEL

4.1 LITRE L-6 ENGINE (RPO L22)

Transmission		3-Speed	3-Speed Automatic	
Rear Axle Ratio		2.56	2.56	2.73*
Tire Size		E78 x 14		
Crankshaft Revolutions per Mile		2040.3		2175.8
Crankshaft RPM @ 1 MPH	Low	119.0	85.7	91.5
	Second	64.3	51.7	55.2
	Third	34.0	34.0	36.3
	Reverse	123.1	65.6	70.4
Piston Travel (ft/mile)		1200.4		1280.1

* - California only.

5.0 LITRE V-8 ENGINE (RPO LG3)

Transmission		4-Speed	3-Speed Automatic	
Rear Axle Ratio		3.08:1	2.41:1	
Tire Size		E78 x 14		
Crankshaft Revolutions per Mile		2454.8	1920.8	
Crankshaft RPM @ 1 MPH	Low	116.6	80.6	
	Second	82.6	48.6	
	Third	55.2	32.0	
	Fourth	40.9	-	
	Reverse	116.6	62.1	
Piston Travel (ft/mile)		1423.8	1114.1	

5.7 LITRE V-8 ENGINE (RPO LM1)

Transmission		3-Speed Automatic	
Rear Axle Ratio		2.41:1	3.08:1
Tire Size		E78-14	
Crankshaft Revolutions per Mile		1920.8	2454.8
Crankshaft RPM @ 1 MPH	Low	80.6	103.1
	Second	48.6	62.2
	Third	32.0	40.9
	Reverse	62.1	78.9
Piston Travel (ft/mile)		1114.1	1636.5

VEHICLE PERFORMANCE FACTORS

ENGINE	4.1 LITRE L-6	5.0 LITRE V-8	5.7 LITRE V-8
MODEL	1XX69	1XX17	1XY27

3-SPEED TRANSMISSION

Performance Weight (pounds)		3889
Pounds/Net Horsepower	Federal	34.69
	California	43.31
Pounds/Cu. In. Displacement		15.56
Net HP/Cu.In. Displacement	Federal	.460
	California	.360
Power Displacement (cu.ft./mile)		147.6
Displacement Factor (cu.ft./ton mile)		75.9

4-SPEED TRANSMISSION

Performance Weight (pounds)		4115
Pounds/Net Horsepower	Federal	31.65
	California	32.92
Pounds/Cu.In. Displacement		13.49
Net HP/Cu.In. Displacement	Federal	.426
	California	.410
Power Displacement (cu.ft./mile)		216.64
Displacement Factor (cu.ft./ton mile)		105.3

3-SPEED AUTOMATIC

Performance Weight (pounds)		3913	4128	4058
Pounds/Net Horsepower	Federal	34.03	31.75	24.59
	California	43.48	33.02	24.59
Pounds/Cu.In. Displacement		15.65	13.53	11.59
Net HP/Cu.In. Displacement	Federal	.460	.426	.471
	California	.360	.410	.471
Power Displacement (cu.ft./mile)		147.6	169.5	194.52
Displacement Factor (cu.ft./ton mile)		77.4	82.1	95.9

GLOSSARY

Performance Weight	Curb Weight plus 600 Lb (weight of four 150 lb passengers)
Power Displacement	$\frac{\text{Crankshaft Revs/Mi} \times \text{Piston Displacement}}{2 \times 1728}$
Displacement Factor	$\frac{\text{Power Displacement}}{\text{Performance Wt (tons)}}$

PRINCIPAL COMPONENTS

CYLINDER BLOCK

Material	Cast alloy iron
Bore Diameter	
4.1 Litre L-6	3.8745-3.8775
5.0 Litre V-8	3.7355-3.7385
5.7 Litre V-8	3.9995-4.0025
Bearing Caps (Number, material and attachment)	
4.1 Litre L-6	7, cast iron, 2-bolt
5.0L, 5.7 Litre V-8	5, cast iron, 2-bolt
Water Jacket	Full length around each cylinder
Bore Spacing (Centerline to Centerline)	4.40

CYLINDER HEAD

Material	High chrome cast alloy iron
Bolt No. & Size	
4.1 Litre L-6	14; .500 dia. 13 threads/in.
5.0, 5.7 Litre V-8	34; .4375 dia. 14 threads/in.

COMBUSTION CHAMBER VOLUME

(Total chamber volume of assembled engine with piston at top center)

4.1 Litre L-6	5.77 Cu. In.
5.0 Litre V-8	5.13 Cu. In.
5.7 Litre V-8	6.27 Cu. In.

INLET MANIFOLD

Material	Cast alloy iron
Type	
4.1 Litre L-6	
49 States	Separate
California	Integral with cylinder head
5.0, 5.7 Litre V-8	8 port, double deck

EXHAUST MANIFOLD

Material	Cast alloy iron
Type	
4.1 Litre L-6	4 port, underslung center downtake
5.0, 5.7 Litre V-8	Dual, 4 port, rear downtake
Outlet Diameter (Nominal)	
4.1 Litre L-6	2.25
5.0 & 5.7 Litre V-8	2.0

CRANKSHAFT

Material	
4.1 Litre L-6	Cast nodular iron
5.0, 5.7 Litre V-8	Cast nodular iron
End Play	
4.1 Litre L-6	.002-.006
5.0, 5.7 Litre V-8	.002-.007
Counter Weights	
4.1 Litre L-6	12
5.0, 5.7 Litre V-8	6
Crank Arm Length	
4.1 Litre L-6	1.765
5.0 Litre V-8	1.740
5.7 Litre V-8	1.740
Torsional Damper	Rubber mounted inertia
Timing Gear	
4.1 Litre L-6	Cast iron
5.0, 5.7 Litre V-8	Sintered iron
Pulley Pitch Diameter	6.64

MAIN BEARINGS

Material	Steel backed insert; (copper lead alloy or premium aluminum lining selected for specific engine application)
Type	Precision removable
Thrust Against Bearing No. -	No. 5 (V-8); No. 7 (L-6)
Clearance	
4.1 Litre L-6	.0003-.0029
5.0, 5.7 Litre V-8	
No. 1	.0008-.0020
No. 2, 3 & 4	.0011-.0023
No. 5	.0017-.0033

Dimensions

	Theoretical Inner Dia.	Effective Length	Projected Area
4.1 Litre L-6			
Bearing No. 1-6	2.2999	.752	1.7295
Bearing No. 7	2.2999	.760	1.7479
5.0, 5.7 Litre V-8			
Bearing No. 1-4	2.4502	.752	1.8425
Bearing No. 5	2.4508	1.180	2.8919

PRINCIPAL COMPONENTS

CRANKSHAFTS AND BEARINGS

4.1 LITRE SIX CYLINDER ENGINE

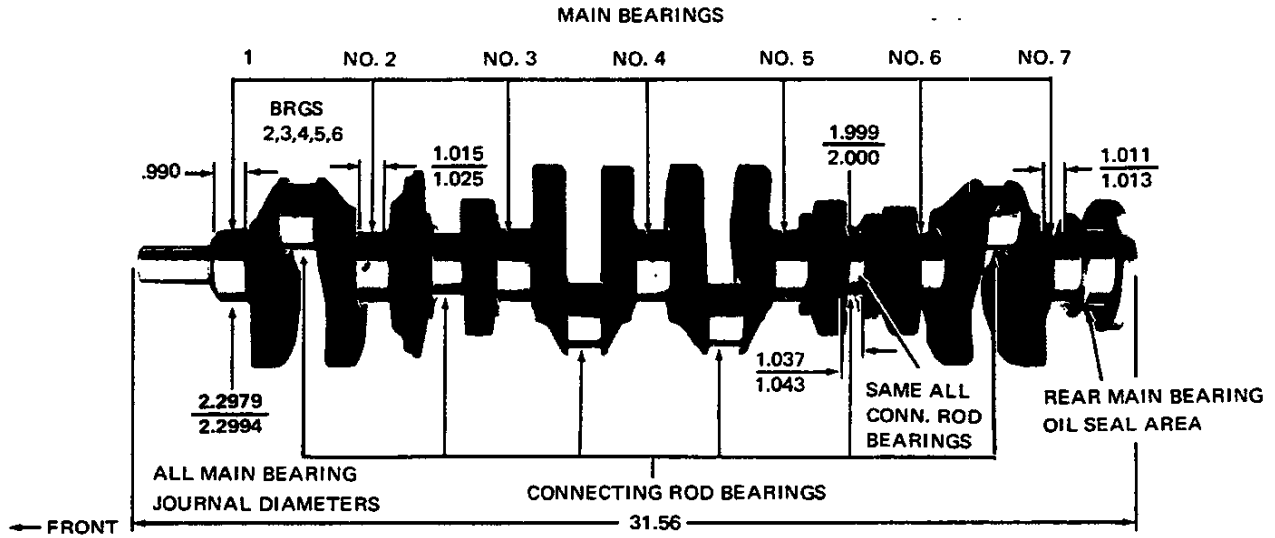

CRANKSHAFTS AND BEARINGS

5.0 AND 5.7 LITRE V-8 ENGINES

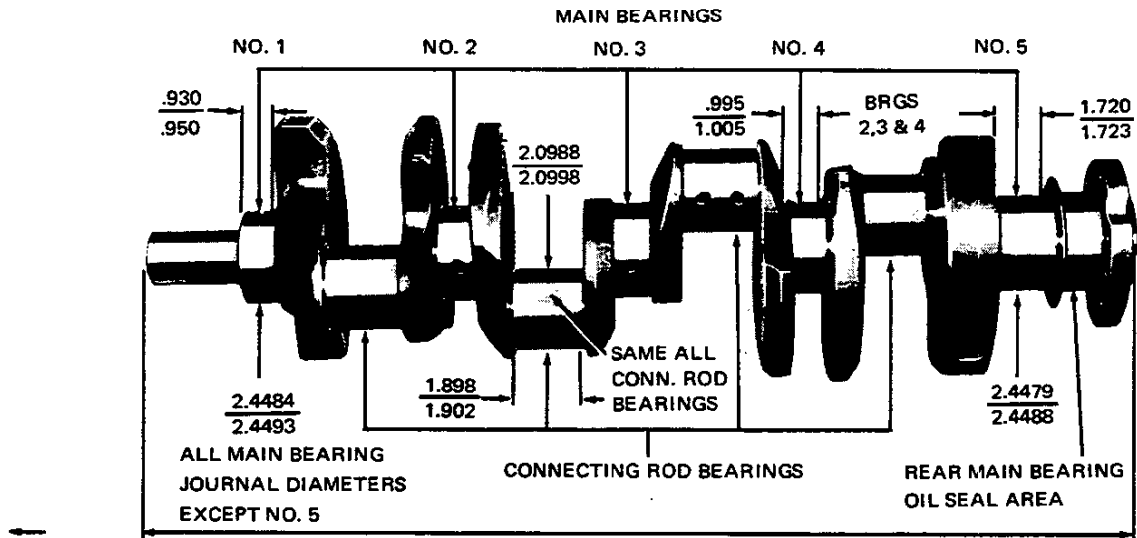

PRINCIPAL COMPONENTS

CAMSHAFT

Material	Cast alloy iron
Drive	
4.1 Litre L-6	Aluminum alloy
5.0, 5.7 Litre V-8	Nylon teeth with aluminum head
Lobe Lift	
4.1 Litre L-6	.2217 Inlet; .2315 Exhaust
5.0 Litre V-8	.2484 Inlet; .2667 Exhaust
5.7 Litre V-8	.2600 Inlet; .2733 Exhaust
Bearings	Steel backed babbit

VALVE TRAIN

Type	Individually mounted, overhead rocker arms, push rod actuated
Lifters	Hydraulic
Rocker arms	
Ratio	
4.1 Litre L-6	1.75:1
5.0, 5.7 Litre V-8	1.50:1
Push rods	
Type	Hollow steel
Ends	Hardened
Rotators (5.0, 5.7 Litre V-8)	Exhaust

VALVE SPRINGS

Diameter (I.D.)	
4.1 Litre L-6	.872-.880
5.0, 5.7 Litre V-8	.868-.884
Installed length (lb. @ in.)	
Valves closed	
4.1 Litre L-6	78-86 @ 1.66
5.0, 5.7 Litre V-8	
Inlet	76-84 @ 1.70
Exhaust	76-84 @ 1.61
Valves opened	
4.1 Litre L-6	170-180 @ 1.26
5.0, 5.7 Litre V-8	
Inlet	194-206 @ 1.25
Exhaust	194-206 @ 1.16
Free length	
4.1 Litre L-6	1.90
5.0, 5.7 Litre V-8	2.03
Valve spring damper	
4.1 Litre L-6	None
5.0, 5.7 Litre V-8	Flat steel, 4 coils
Oil shield	Steel cup

CAMSHAFT AND BEARINGS

4.1 LITRE L-6 ENGINE

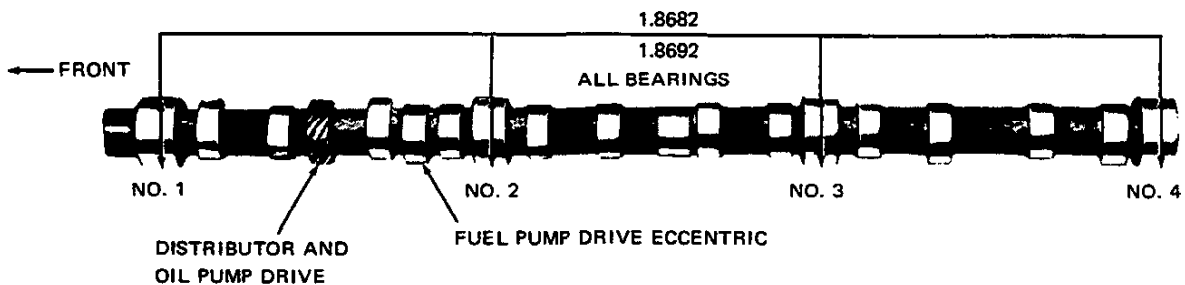

PRINCIPAL COMPONENTS

INLET VALVES

Material	Alloy steel
Coating	
4.1 Litre L-6 & 5.0 Litre V-8	Aluminized face
5.7 Litre V-8	None
All stems	Chrome flash

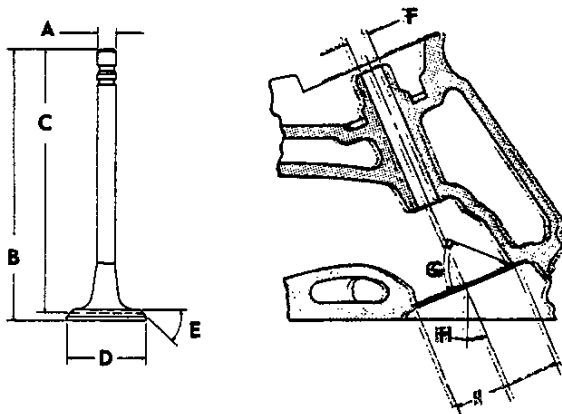

A - Stem diameter	.3410-.3417
B - Overall length	
4.1 Litre L-6	4.902-4.922
5.0 Litre V-8	4.902-4.922
5.7 Litre V-8	4.870-4.889
C - Gage length	4.781-4.795
D - Overall head diameter	
4.1 Litre L-6	1.715-1.725
5.0 Litre V-8	1.715-1.725
5.7 Litre V-8	1.933-1.945
E - Angle of face	45°
F - Guide diameter	.3427-.3437
G - Angle of seat	46°
H - Valve angle	
4.1 Litre L-6	9°
5.0, 5.7 Litre V-8	23°
I - Valve seat diameter	
4.1 Litre L-6	1.591-1.597
5.0 Litre V-8	1.823-1.829
5.7 Litre V-8	1.823-1.829

EXHAUST VALVES

Material	High alloy steel
Coating	
4.1 Litre L-6	Aluminized face
5.0, 5.7 Litre V-8	Aluminized face
All stems	Chrome flash

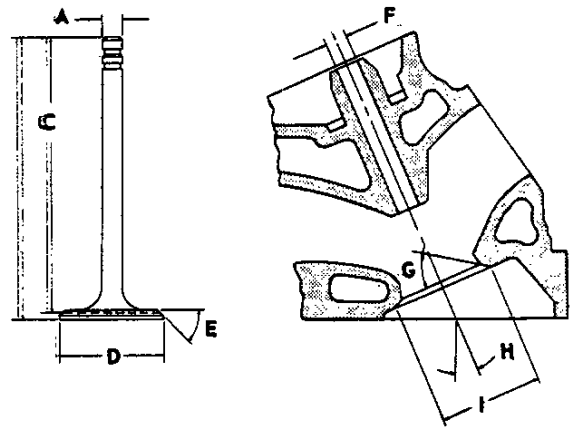

A - Stem diameter	.3410-.3417
B - Overall length	
4.1 Litre L-6	4.913-4.933
5.0 Litre V-8	4.913-4.933
5.7 Litre V-8	4.910-4.930
C - Gage length	4.781-4.791
D - Overall head diameter	
4.1 Litre L-6	1.495-1.505
5.0 Litre V-8	1.495-1.505
5.7 Litre V-8	1.495-1.505
E - Angle of face	45°
F - Guide diameter	.3427-.3437
G - Angle of seat	46°
H - Valve angle	
4.1 Litre L-6	9°
5.0, 5.7 Litre V-8	23°
I - Valve seat diameter	
4.1 Litre L-6	1.321-1.327
5.0 Litre V-8	1.321-1.327
5.7 Litre V-8	1.321-1.327

PRINCIPAL COMPONENTS

VALVE LIFT

4.1 Litre L-6	.3880 Inlet; .4051 Exhaust
5.0 Litre V-8	.3727 Inlet; .4100 Exhaust
5.7 Litre V-8	.3900 Inlet; .4100 Exhaust

VALVE TIMING (Crankshaft Degrees - Excluding Ramps)

4.1 Litre L-6	
Inlet Valve	
Opens - BTC	16°
Closes - ABC	48°
Duration	244°
Exhaust Valve	
Opens - BBC	64°
Closes - ATC	50°
Duration	294°
5.0 Litre V-8	
Inlet Valve	
Opens - BTC	28°
Closes - ABC	64°
Duration	272°
Exhaust Valve	
Opens - BBC	78°
Closes - ATC	30°
Duration	288°
5.7 Litre V-8	
Inlet Valve	
Opens - BTC	28°
Closes - ABC	72°
Duration	280°
Exhaust Valve	
Opens - BBC	78°
Closes - ATC	30°
Duration	288°

PISTONS

Material	Cast aluminum alloy
Head type	
4.1 Litre L-6	Sump
5.0, 5.7 Litre V-8	Sump
Skirt type	Slipper
Top land clearance	
4.1 Litre L-6	.0245-.0335
5.0 Litre V-8	.0245-.0335
5.7 Litre V-8	.0235-.0325
Skirt clearance	
4.1 Litre L-6	.0005-.0015
5.0 Litre V-8	.0017-.0042
5.7 Litre V-8	.0007-.0017
Compression ring groove depth	
4.1 Litre L-6	.2153-.2218
5.0 Litre V-8	.2003-.2073
5.7 Litre V-8	.2218-.2308
Oil ring groove depth	
4.1 Litre L-6	.2093-.2158
5.0 Litre V-8	.2103-.2193
5.7 Litre V-8	.2038-.2103
Pin bore offset	.055-.065
Compression height	
4.1 Litre L-6	1.658-1.662
5.0 Litre V-8	1.538-1.562
5.7 Litre V-8	1.558-1.562

PISTON PINS

Material	Chromium steel
Length	
4.1 Litre L-6	2.990-3.010
5.0, 5.7 Litre V-8	2.990-3.010
Diameter	
4.1 Litre L-6	.9270-.9273
5.0, 5.7 Litre V-8	.9270-.9273
Clearance in Piston	
4.1 Litre L-6	.00015-.00025
5.0, 5.7 Litre V-8	.00025-.00035
Pin Mounting	Locked in rod by shrink fit

PRINCIPAL COMPONENTS

COMPRESSION RINGS – UPPER

Material	Cast alloy iron
Type	Straight edge inside of ring
Face	Barrel
Coating	
4.1 Litre L-6	Wear resistant coating molybdenum inlay, graphite impregnated
5.0, 5.7 Litre V-8	Chrome flash
Width	
4.1 Litre L-6	.0775-.0780
5.0 Litre V-8	.0770-.0780
5.7 Litre V-8	.0775-.0780
Wall Thickness	
4.1 Litre L-6	.184-.194
5.0 Litre V-8	.167-.177
5.7 Litre V-8	.190-.200
Gap	.010-.020

COMPRESSION RINGS – LOWER

Type	Inside bevel (top of ring 30 degrees to piston vertical axis)
Face	Tapered
Coating	Wear resistant
Width	
4.1 Litre L-6	.0770-.0780
5.0 Litre V-8	.0770-.0775
5.7 Litre V-8	.0770-.0775
Wall Thickness	
4.1 Litre L-6	.184-.194
5.0 Litre V-8	.167-.177
5.7 Litre V-8	.190-.200
Gap	
4.1 Litre L-6	.010-.020
5.0 Litre V-8	.010-.025
5.7 Litre V-8	.010-.025

OIL CONTROL RINGS

Type	Multi-piece (two rails and one spacer)
Material	
Rails	Steel
Spacer	Alloy steel
Width (assembled)	
4.1 Litre L-6	.1850-.1870
5.0 Litre V-8	.1859-.1879
5.7 Litre V-8	.1850-.1870
Wall Thickness	
4.1 Litre L-6	.152-.158
5.0 Litre V-8	.138-.143
5.7 Litre V-8	.150-.156
Gap	
4.1 Litre L-6	.015-.055
5.0 Litre V-8	.010-.035
5.7 Litre V-8	.015-.055
Rail Coatings	Chrome plated

CONNECTING RODS

Material	Drop forged steel
Length (Center to Center)	5.695-5.705

CONNECTING ROD BEARINGS

Material	
4.1 Litre L-6	Premium aluminum
5.0, 5.7 Litre V-8	Premium aluminum
Type	Precision removable
Clearance	
4.1 Litre L-6	.0007-.0027
5.0, 5.7 Litre V-8	.0013-.0035
Theoretical I. D.	
4.1 Litre L-6	2.0017
5.0, 5.7 Litre V-8	2.1012
Effective Length	
4.1 Litre L-6	.807
5.0, 5.7 Litre V-8	.797
End Play	
4.1 Litre L-6	.007-.016
5.0 Litre V-8	.006-.016
5.7 Litre V-8	.006-.016

FUEL TANK

Capacity (Gal)	21 (approximately)
Fuel tank location	Attached to underbody behind rear axle
Filler location	Behind hinged rear license plate

FUEL FILTERS

In Fuel Tank	Mesh strainer
In Carburetor Inlet	Paper

FUEL PUMP ASSEMBLY

Type	Mechanical; diaphragm
Drive	Camshaft, eccentric
Location	Right side front of engine
Pressure range (shut off pressure at 1800 rpm)	
4.1 Litre L-6	4.5-6.0 psi at pump outlet
5.0 Litre V-8	7.50-9.00 psi at pump outlet
5.7 Litre V-8	7.50-9.00 psi at pump outlet

AIR CLEANER

Type	Cylindrical with air horn attached to ducted air inlet
Diameter	
4.1 Litre L-6	12.62
5.0, 5.7 Litre V-8	15.48
Filter element	Oil-wetted paper

CARBURETORS

Make and type	
4.1 Litre L-6	1-barrel, Monojet
5.0 Litre V-8	2-barrel
5.7 Litre V-8	4-barrel
SAE flange type	
4.1 Litre L-6	1.50
5.0, 5.7 Litre V-8	1.50
Throttle bore	
4.1 Litre L-6	1.69
5.0 Litre V-8	1.69
5.7 Litre V-8	
Primary	1.38
Secondary	2.25
Secondary throttle actuation	By linkage approximately when primary valves are opened halfway between closed and open
Venturi diameter	
4.1 Litre L-6	1.31
5.0 Litre V-8	1.19
5.7 Litre V-8	
Primary	2.25
Secondary	Air valve

CHOKE

Type	Automatic
----------------	-----------

EXHAUST SYSTEMS

TYPE

4.1 Litre L-6	Single exhaust, single converter with crossover
5.0, 5.7 Litre V-8	Single exhaust, single converter with crossover and dual tail pipes

MUFFLERS

Type	Oval, reverse flow
Construction	Heads and body joined by rolled lock seam construction
Heads	
4.1 Litre L-6	.054 sheet steel, aluminized
5.0 Litre V-8	.054 sheet steel, aluminized
5.7 Litre V-8	.054 sheet steel, aluminized
Shell	
4.1 Litre L-6	.031 sheet steel, aluminized
5.0, 5.7 Litre V-8	.031 sheet steel, aluminized
Wrap	.060 indented asbestos sheet
Cover	.017 sheet steel, aluminized
Length, Body	24.00
Width (I.D.)	10.75
Height (I.D.)	4.06

EXHAUST CROSSOVER PIPE TO CONVERTER

Dimensions (O.D.) & Wall Thickness	
4.1 Litre L-6	2.25 x .078 laminated
5.0, 5.7 Litre V-8	
Crossover	2.00 x .078 laminated
To Converter	2.50 x .078 laminated

EXHAUST PIPE - CONVERTER TO MUFFLER

Dimensions (O.D.)	
4.1 Litre L-6	2.25
5.0, 5.7 Litre V-8	2.25
Wall Thickness	
4.1 Litre L-6	.071 laminated
5.0, 5.7 Litre V-8	.071 laminated

TAIL PIPES

Dimensions (O.D.)	
4.1 Litre L-6	2.00
5.0, 5.7 Litre V-8	2.00
Wall Thickness	
4.1 Litre L-6	.056
5.0, 5.7 Litre V-8	.056

EMISSION CONTROL EQUIPMENT

SYSTEM APPLICATION

System Type	Engine Adaptation		
	4.1 Litre	5.0 Litre	5.7 Litre
CHA - Carburetor Hot Air	a, c	-	-
COA - Carburetor Outside Air	a, c	a, c	b, c
CTS - Cold Trapped Spark	a	a, c	-
EFE - Early Fuel Evaporation	a, c	a, c	b, c
EGR - Exhaust Gas Recirculation	a, c	a, c	b, c
FEC - Fuel Evaporation Control	a, c	a, c	b, c
PCV - Positive Crankcase Ventilation	a, c	a, c	b, c
UFC - Under Floor Converter	a, c	a, c	b, c
MAI - Manifold Air Injection	c	c	b, c
MMC - Monolith Manifold Converter	c	-	-
T-CHA - Trapped - Carburetor Hot Air	-	a, c	b, c

a - 49 states without Altitude RPO NA6

b - 49 states with Altitude RPO NA6

c - California

BASIC FUNCTION OF SYSTEMS

CARBURETOR HOT AIR SYSTEM

A thermostatically controlled air induction system designed to aid carburetion. Consists of a heat stove to supply preheated air and a vacuum powered damper to mix air normally drawn in through the snorkel with the hot air. Produces a more uniform carburetor air temperature which permits proper emission control with improved engine operation.

CARBURETOR OUTSIDE AIR

Duct work connecting air cleaner snorkel to air source outside of engine compartment. Provides cooler outside air to CHA system for improved performance after engine warm-up.

COLD TRAPPED SPARK

Maintains distributor spark advance during heavier load accelerations for improved performance during engine warm-up.

EARLY FUEL EVAPORATION

A thermostatically controlled system designed to supply hot exhaust gases to heat carburetor base and inlet manifold during early stages of cold engine operation. Improves cold engine driveability during warm-up.

EXHAUST GAS RECIRCULATION SYSTEM

Meters exhaust gas into induction system for recirculation throughout the combustion cycle to reduce oxides of nitrogen emissions.

FUEL EVAPORATION CONTROL SYSTEM

Controls emission of gasoline vapors to the atmosphere by means of an integral separator with the fuel tank that separates vapor from liquid fuel - a filler cap that doesn't permit venting into the atmosphere - a canister for storage of vapors - lines, hoses and valves to control and transport vapors from fuel tank and carburetor float bowl to storage, and finally, to the carburetor for utilization in running the engine.

POSITIVE CRANKCASE VENTILATION

Withdraws oil and gas vapors from the various cavities throughout the engine for burning in the combustion cycle.

UNDERFLOOR CATALYTIC CONVERTER

A device placed in the exhaust system containing the catalytic bed through which exhaust gasses are passed. The catalyst may be configured to cause both a reduction and oxydation reaction, or an oxydation reaction only.

MANIFOLD AIR INJECTION

Compresses, regulates and distributes quantities of air to the exhaust manifold to more completely burn carbon monoxide and hydrocarbon emissions.

MONOLITH MANIFOLD CONVERTER

The flow of exhaust gasses down through the catalyst within the converter, effectively controls the hydrocarbon and carbon monoxide to a more desirable emission.

TRAPPED - CARBURETOR HOT AIR

Check valve added to CHA system to delay damper valve opening to cold air source during large throttle settings for improved driveability during warm-up.

LUBRICATION SYSTEM

GENERAL

Type	Controlled full pressure
Main Bearings	Pressure
Connecting Rods	Pressure
Piston Pins	Splash
Cylinder Walls	
4.1 Litre L-6	Main and connecting rod bearing throw off
5.0, 5.7 Litre V-8	Pressure, jet cross sprayed
Camshaft Bearings	Pressure
Valve Lifters	Pressure
Rocker Arms	Pressure
Timing Gears	
4.1 Litre L-6	Nozzle sprayed
5.0, 5.7 Litre V-8	Centrifugally oiled from camshaft bearing
Oil Pressure Sending Unit	
Type	Electric
Actuation	Opens or closes circuit @ 2 to 6 PSI
Oil Filler	
Cap	Positive seal
Location	
4.1 Litre L-6	Forward end of rocker cover
5.0, 5.7 Litre V-8	Rearward on left rocker cover

OIL PAN CAPACITIES (Quarts)

Refill	
4.1 Litre L-6	4
5.0, 5.7 Litre V-8	4
Refill with Filter Change	
4.1 Litre L-6	4.5
5.0, 5.7 Litre V-8	4.5

LUBRICANT GRADES AND TEMPERATURES

20° and Above	10W-30, 10W-40, 20W-20 20W-40, 20W-50
0° to 60° above	10W, 5W-30, 10W-30, 10W-40
Below 20°F	5W, 5W-20, 5W-30

OIL PUMP

Type	Gear
Regulator Valve	Opens between 40-45 lbs,
Oil Pressure	
4.1 Litre L-6	36-41 PSI @ 2000 RPM
5.0, 5.7 Litre V-8	45 PSI @ 2000 RPM
Intake Type	Fixed pickup with screen
Capacity (GPM @ Engine RPM)	
4.1 Litre L-6	4.3 @ 2000
5.0, 5.7 Litre V-8	4.3 @ 2000

OIL FILTER

Type	Full flow, throw away canister
Location	
4.1 Litre L-6	Right side front of engine
5.0, 5.7 Litre V-8	Left rear side of engine
Capacity	0.53 pint
Bypass Valve	Opens between 9 to 11 PSI

OIL PAN DRAIN PLUG

Type	Hex head
Location	
4.1 Litre L-6	Front lower face of oil pan sump
5.0, 5.7 Litre V-8	Left lower face of oil pan sump
Size of Hex Head	.860-.875
Thread	1/2-20 UNF 2A
Length	0.81
Diameter	.410-.430

OIL DIPSTICK - LOCATION

4.1 Litre L-6	Right side rear of engine block
5.0, 5.7 Litre V-8	Left side center rear of engine block

COOLING SYSTEM

GENERAL

Type	Pressure, vented thru coolant recovery system
Capacity with Heater	
4.1 Litre L-6	13.6 qts
5.0 Litre V-8	16.0 qts
5.7 Litre V-8	16.0 qts

RADIATOR

Make and Type	Harrison, tube and center	
Core constant		
Distance between fins	<u>Manual</u>	<u>Auto.</u>
4.1 Litre L-622	.20
5.0 Litre V-820	.16
5.7 Litre V-8	-	.18
Distance between tubes55	
Thickness of core		
4.1 Litre L-6	1.24	
5.0 Litre V-8	1.24	
5.7 Litre V-8	1.24	
Frontal Areas		
4.1 Litre L-6	353	
5.0 Litre V-8	353	
5.7 Litre V-8 (Auto. Trans.)	446	
Overflow	Separate coolant bottle	

RADIATOR HEAVY DUTY (RPO V01)

Core constant		
Distance between fins	<u>Manual</u>	<u>Auto.</u>
4.1 Litre L-618	.16
5.0 Litre V-816	.16
5.7 Litre V-8	-	.20
Distance between tubes55	
Thickness of core		
4.1 Litre L-6	1.24	
5.0 Litre V-8	1.24	
5.7 Litre V-8 (Auto. Trans.)	1.96	
Frontal area (sq. in.)		
4.1 Litre L-6	446	
5.0, 5.7 Litre V-8	446	
Overflow	Separate coolant bottle	

THERMOSTAT

Type	Pellet
Begins to Open at	192°-198°
Fully Opened at	227°

RADIATOR CAP RELIEF VALVE

Opens at Approximately 15 PSI

RADIATOR HOSE

Outlet, lower (radiator to water pump)	1.75 ID
Inlet, upper (thermostat housing to radiator)	1.50 ID

FAN

Number of Blades	
4.1 Litre L-6 & 5.0 Litre V-8	4
5.7 Litre V-8	7
Diameter	
4.1 Litre L-6	17.62
5.0 Litre V-8	18.00
5.7 Litre V-8	19.00

BELTS, CRANKSHAFT, FAN AND GENERATOR

Number used	One
Angle of "V"	34°-38°
Pitch line	
4.1 Litre L-6	38.00
5.0 Litre V-8	
(Except California)	44.50
5.0 Litre V-8 (California)	48.00
5.7 Litre V-8 (California)	48.00
Width380

WATER PUMP

Type	Centrifugal
Capacity	
4.1 Litre L-6	21.0 GPM @ 2000 engine RPM
5.0, 5.7 Litre V-8	22.7 GPM @ 2000 engine RPM
Bearing	Permanently lubricated double row ball
Drive	Fan belt
Ratio (pump to engine rpm)	
4.1 Litre L-6	1.165:1
5.0, 5.7 Litre V-8949:1

DRAIN LOCATIONS AND TYPE

Engine block; Plug	
4.1 Litre L-6	Left side rear
5.0, 5.7 Litre V-8	Right and left side
Radiator-Petcock	
All Types	Lower left rear face

ELECTRICAL SYSTEM

SUPPLY SYSTEM

BATTERY

Type Freedom
 Voltage Rating and Watts
 4.1 Litre L-6 12-2500
 5.0, 5.7 Litre V-8 12-3200
 Cold Cranking Rating
 4.1 Litre L-6 0° @ 275 amps;
 - 20° @ 210 amps. @ 60 minutes reserve capacity
 5.0, 5.7 Litre V-8 0° @ 350 amps;
 - 20° @ 270 amps. @ 80 minutes reserve capacity
 Terminal Grounded Negative
 Location . . . Engine compartment, right side front

GENERATOR

Type Diode rectified
 Rating
 Amps 37
 Volts 12
 Drive By fan belt
 Pulley Pitch Diameter 2.43
 Ratio (Gen. to Engine Speed) 2.73:1

REGULATOR

Type Micro circuit unit
 integral with alternator
 Voltage 13.8-14.8 @ 85°F

IGNITION SYSTEM

DISTRIBUTORS Refer to chart below

CABLE Linen core impregnated
 with electrical conducting material and
 insulation of rubber with neoprene jacket

COIL

Type Integral with distributor

SPARK PLUGS

Type
 4.1 Litre L-6 R46TS
 5.0, 5.7 Litre V-8 R45TS
 Thread Size (mm) 14
 Gap
 4.1 Litre L-6 0.035
 5.0, 5.7 Litre V-8 0.045
 Torque (lb. ft.) 25

STARTING SYSTEM

STARTING MOTOR

Rotation (Drive End View) Clockwise
 Test Conditions Engine at operating temp.
 No Load Test
 Amps
 4.1 Litre L-6 49-87
 5.0, 5.7 Litre V-8 70-99
 Volts 10.6
 RPM
 4.1 Litre L-6 6200-10700
 5.0, 5.7 Litre V-8 7800-12000

Motor Drive

Engagement Solenoid
 Pinion Meshes at Rear
 Pinion Tooth No. 9
 Flywheel Teeth No.
 4.1 Litre L-6 153
 5.0, 5.7 Litre V-8 168
 Mounting Bolted to cylinder block flange

DISTRIBUTORS	4.1 Litre L-6 RPO L22		5.0 Litre V-8 RPO LG3			5.7 Litre V-8 RPO LMI	
	Model	(1110716)	1103281	1103379	(1103285)	1103353	(1103285)
Type	High Energy Ignition (H.E.I.)						
Centrifugal Advance begins @ RPM	0 @ 1000		0 @ 1000	0 @ 1000	0 @ 1200	0 @ 1100	0 @ 1200
Max. Degrees @ RPM	20 @ 4200		20 @ 3800	20 @ 3800	22 @ 4200	22 @ 4600	22 @ 4200
Vacuum Advance begins @ " Hg.	0 @ 4						
Max. Degrees @ " Hg.	20 @ 10	15 @ 12	20 @ 10	20 @ 8	10 @ 8	20 @ 10	10 @ 8
Timing (Initial design setting) Crankshaft deg. @ RPM w/vacuum line disconnected	12° BTC	8° BTC 6° BTC	4° BTC			6° BTC	8° BTC
Timing Mark Location	Torsional damper						

Data in brackets () pertains to California.

TRANSMISSIONS AND CLUTCHES

CLUTCHES

Engine	Type - Cubic Inch Availability	4.1 Litre L-6 Standard (RPO L22)	5.0, 5.7 Litre V-8 RPO LG3	
Type		Single dry disc centrifugal		
Clutch cover & pressure plate	Eff. plate load, lb.	2100-2300		
	Press. plate matl.	Nodular iron		
	Clutch spring type	Diaphragm bent finger		
	Clutch spring matl.	Heat treated spring steel		
Driven plate	Type	Single disc with two friction discs		
	Cushions	Flat spring steel between friction rings		
	Dampers	10 coil springs (5 sets of two)		
	Friction rings	OD	10.34	
		ID	6.50	
		Total area sq. in.	101.54	
Material		Woven type asbestos		
Flywheel & Ring Gear	Flywheel Material	Nodular iron		
	Ring Gear	Material	Heat treated HR steel	
		No. of teeth	153	
		PD	12.75	
		Attachment	Shrink fit	
Bearings	Release	Type	Single row ball	
		Lubrication	None, prepacked	
	Pilot	Type	Bronze bushing	
		Lubrication	None, sintered and oil impregnated	
Control	Clutch fork	Drop forged steel, pivot mounted on ball		
	Pedal mounting	Pendant from brace on dash		
	Lubrication	Crossover shaft		
Clutch housing material		Aluminum alloy		

3 AND 4-SPEED TRANSMISSIONS

Transmission	3-Speed	4-Speed		
Engine Type - Cubic Inch	4.1 Litre L-6	5.0 Litre V-8		
Application Availability	Standard	LG3		
Case Material		Cast iron		
Gear Shift	Type	Remote		
	Control	Lever		
	Location	Steering column	Floor	
Gears	Type	Helical		
	Material	Forged steel hardened		
	Synchronization	All forward gears		
	Constant mesh gear	All gears	All forward gears	
	Sliding	None	Reverse	
	Ratios	First	3.50:1	2.85:1
		Second	1.89:1	2.02:1
		Third	1.00:1	1.35:1
Fourth		--	1.00:1	
Reverse		3.62:1	2.85:1	
Lubricant	Type	GL-5 Gear Lubricant (80W or 80W-90)		
	Capacity (pts)	3	3.4	
Extension	Material	Cast iron		
	Oil	Steel encased seat of spring loaded silicone		

TRANSMISSIONS

THREE-SPEED AUTOMATIC TRANSMISSION

Engine	Displacement	4.1 Litre L-6; 5.0, 5.7 Litre V-8	
General Data	Type	Automatic hydraulic torque converter with compound planetary gear system - three forward speeds and reverse.	
	Selector lever	Location	Steering column (a)
		Operation	Actuates controls by a hydraulic system from pressurized gear type pump
		Quadrant pattern	P-R-N-D-L2-L1
	Parking Lock	Type	Locking pawl
		Operation	Applied by selector lever through manual linkage
	Method of cooling		Water
Flywheel assembly		Steel stamping with welded on ring gear	
Hydraulic System	Oil pressure pump	Supplies hydraulic pressure from an engine driven gear type pump	
	Type	Steel spool valve	
	Valves	Manual	Establishes range of transmission operation
		Pressure regulator	Provides main line pressure
		Shift (1-2)	Controls oil pressure for transmission shift from 1-2 or 2-1
		Shift (2-3)	Controls oil pressure for transmission shift from 2-3 or 3-2
	Modulator		Regulates line pressure with modulator oil pressure which varies with torque to transmission
	Accumulator		Provides greater flexibility in attaining desired shift quality for various engine requirements
	Pressure @ Idle (b)	Drive	60
		L2	87
L1		87	
Reverse		91	
Converter Assembly	Pump (Drive member)	Multivane type, sheet metal blade spot welded to steel pump housing that is an integral part of the converter housing	
	Turbine (Driven member)	Steel axial flow blades assembled between inner & outer steel shells	
	Stator assembly	Aluminum multivane type blades mounted on a one way (overrunning) roller clutch	
	Stall ratio	2.00	
	Stall speed (RPM)	2110	
	Diameter (nominal)	11.75	
Planetary Gear Set	Reaction carrier assembly	4 steel pinion gears	
	Output carrier assembly	4 steel pinion gears	
	Intermediate band	Circular steel with organic lining	
	Range	D (Drive)	2.52:1 - 1.52:1 - 1.00:1
		L2 (Low two)	2.52:1 - 1.52:1
		L1 (Low one)	2.52:1
R (Reverse)		1.93:1	
Servo Unit		Piston with release spring and inner cushion spring	
Case	Material	Aluminum	
Clutches	Type	Four, multiple disk	
	Material	Drive plates	Steel with bonded organic facings
		Driven plates	Flat steel
	Forward clutch		5 each drive & driven plates
	Direct clutch		4 each drive & driven plates
	Intermediate clutch		3 each drive & driven plates
	Low & Reverse clutch		5 each drive & driven plates
Release spring		Radial row steel coil	
Torque Multiplication	Drive (maximum)	5.04:1 to 1.00	
	Low 2	5.04:1 to 1.52	
	Low 1	5.04:1 to 2.52	
	Reverse	3.86:1 to 1.93	
Governor	Type	Cross-axis centrifugal	
	Operation	Regulates a pressure proportional to car speed which acts upon the (1-2) (2-3) shift and modulator valves	
Lubricant	Type	Dexron II	
	Capacity (pints)	Dry	20
		Refill	8

(a) Floor mounted available when bucket seats are used; quadrant changes to P-R-N-3-2-1.

(b) Conditions: 600 RPM input

ALPHABETICAL OPTION INDEX

(Not for ordering purposes)

Option Number	Description	Option Number	Description
AB8	ROOF COVER: Cabriolet	P01	WHEEL TRIM: Wheel Covers, Full
AK1	BELTS, DELUXE: Color-Keyed Seat and Shoulder	QBT	TIRES: FR78-14/B White Lettered (Radial)
AU3	DOOR LOCK SYSTEM, POWER	QDV	TIRES: FR78-14/B Blackwall (Radial)
A01	GLASS, TINTED: All Windows	QDW	TIRES: FR78-14/B White Stripe (Radial)
A20	WINDOWS: Swing-Out Rear Side	QEG	TIRES: E78-14/B Blackwall (Bias Belted)
A31	WINDOWS, POWER	QEH	TIRES: E78-14/B White Stripe (Bias Belted)
BW2	MOLDINGS: Body Side, Deluxe	TR9	LIGHTING, AUXILIARY
B3W	PRELIMINARY PRICE INFORMATION	UA1	BATTERY, HEAVY-DUTY
B37	FLOOR COVERING: Mats, Color-Keyed Floor, Front and Rear	UF7	GAGE PACKAGE
B51	MOLDINGS: Bright Rocker	UM1	RADIO EQUIPMENT: AM Radio with 8-Track Stereo Tape
B74	MOLDINGS: Wheel Opening, Wide	UM2	RADIO EQUIPMENT: AM/FM Stereo Radio with 8-Track Stereo Tape
B80	MOLDINGS: Roof Drip	UN3	RADIO EQUIPMENT: AM/FM Stereo Radio with Stereo Cassette Tape
B84	MOLDINGS: Body Side	UY8	RADIO EQUIPMENT: AM/FM Stereo Radio with Digital Clock Display
B90	MOLDINGS: Side Window Reveal	U05	HORNS, DUAL
B93	MOLDINGS: Door Edge Guard	U14	INSTRUMENTATION: Special
B96	MOLDINGS: Wheel Opening	U35	CLOCK: Electric
CD4	WINDSHIELD WIPER SYSTEM: Intermittent	U58	RADIO EQUIPMENT: AM/FM Stereo Radio
C50	DEFOGGER, REAR WINDOW: Blower Type	U63	RADIO EQUIPMENT: AM Radio
C60	AIR CONDITIONING	U69	RADIO EQUIPMENT: AM/FM Radio
D31	MIRROR: Inside Rearview, Day-Night	U76	RADIO EQUIPMENT: Windshield Antenna
D33	MIRROR: Outside Rearview, LH Remote Control	U80	RADIO EQUIPMENT: Speaker, Rear Seat
D35	MIRRORS: Sport, LH Remote and RH Manual	V01	RADIATOR, HEAVY-DUTY
D55	CONSOLE	V30	BUMPER EQUIPMENT: Bumper Rub Strips and Guards
D60	NON-RECOMMENDED COLOR COMBINATION	YF5	EMISSION SYSTEM: California Emission Requirements
D85	STRIPING, PIN: Body Side	ZJ3	INTERIOR DECOR PACKAGE
F40	SUSPENSION EQUIPMENT: Suspension, Heavy-Duty Front and Rear	ZJ5	VALUE APPEARANCE GROUP
F41	SUSPENSION EQUIPMENT: Suspension, Sport	ZJ7	WHEEL TRIM: Wheels, Rally. Color-Keyed
G80	AXLE, REAR: Limited Slip Differential	Z26	NOVA RALLY EQUIPMENT
G92	AXLE, REAR: Performance Ratio	11A	STRIPING: White
J50	BRAKES, POWER	13A	STRIPING: Silver
K30	SPEED CONTROL: Automatic	19A	STRIPING: Black
LG3	ENGINE: 5.0 Litre 2 BBL V8	27A	STRIPING: Light Blue
LM1	ENGINE: 5.7 Litre 4 BBL V8	49A	STRIPING: Light Green
L22	ENGINE: 4.1 Litre 1 BBL L6	54A	STRIPING: Gold
MM3	TRANSMISSION: 3-Speed Manual	75A	STRIPING: Red
MM4	TRANSMISSION: 4-Speed Manual	80A	STRIPING: Orange
MX1	TRANSMISSION: Automatic	15Q	MOLDINGS: Silver
NA5	EMISSION SYSTEM: Standard Emission Equipment	22Q	MOLDINGS: Light Blue
NA6	EMISSION SYSTEM: High Altitude Emission Equipment	40Q	MOLDINGS: Light Green
N33	STEERING WHEEL: Comfortilt	61Q	MOLDINGS: Beige
N41	STEERING, POWER	79Q	MOLDINGS: Dark Carmine
N65	STOWAWAY SPARE TIRE		
N95	WHEEL TRIM: Wheel Covers, Wire		

VINYL ROOF SELECTION

Vinyl Roof	Code	Exterior Color Availability	
		Recommended	Acceptable
Beige	UU	61, 63 or 69	11 or 19
Black	RR	11, 15, 19, 24, 51, 61 or 75	22, 29, 40, 44, 63 or 77
Blue, Light (Met)	DD	11, 19, 22 or 29	
Carmine, Dark (Met)	RR	77	
Green, Light	GG	40 or 44	
Silver	QQ	15 or 19	24, 29 or 77
White	WW	All except 15	15

COLOR AND TRIM SELECTION

PLEASE NOTE: The exterior and interior combinations shown in the chart below and designated as recommended (R), represent the ideal combinations. Those that are shown as acceptable (A), are attractive, but less desirable than the recommended combinations. Orders for additional combinations may be submitted, provided the dealer checks the appropriate order form box (D60), as verification that the requested combination is definitely desired. **CAUTION:** Please utilize available color samples when ordering, especially when adding a third color element (Vinyl Top, Exterior Color, Interior Trim) in order to avoid undesirable combinations.

Seat, Headliner and Door Trim Color	Blue	Camel	Carmine	White	White	White
Instrument Panel Pad and Carpet Color	Blue	Camel	Carmine	Black	Blue	Carmine

MODEL	SEAT TYPE						
1XY27	Custom Sport Cloth Bench	EDD1	ECC1	ERR1			
	Custom Vinyl Bench		XCC1	XRR1	XWB1	XWD1	XWR1
	Custom Vinyl Bucket		XCC2	XRR2			
1XY69	Custom Sport Cloth Bench	EDD1	ECC1	ERR1			
	Custom Vinyl Bench		XCC1	XRR1			

EXTERIOR PAINT COLOR	COLOR CODE			L	U	T				
	L	U	T							
Beige	61	61	—				R	A	A	
Black	19	19	—	R	R		R	R		R
Blue, Bright (Met)	24	24	11	A	A			R	A	
Blue, Dark (Met)	29	29	—	R	A			A	R	
Blue, Light (Met)	22	22	—	R				A	R	
Brown, Dark (Met)	69	69	61		R			A		
Camel (Met)	63	63	61		R			A		
Carmine (Met)	77	77	11		A	R		A		R
Green, Light	40	40	—		A			A		
Green, Medium (Met)	44	44	11		A			A		
Red	75	75	11		A	A		A		A
Silver	15	15	—	A			R	R		
White	11	11	—	R	R	R	R	R	R	R
Yellow, Bright	51	51	—		A			R		

L = Lower U = Upper T = Two-Tone

POWER TEAMS

(Refer to next page for option availability and application)

ENGINE OPTION CONDITION		AXLE RATIO			
		2.41	2.56	2.73	3.08
WITHOUT YF5 CALIFORNIA OR NA6 HIGH ALTITUDE EMISSIONS					
L22	MM3 or MX1	—	Std	—	—
LG3	MM4 MX1	— Std	—	—	Std G92
WITH YF5 CALIFORNIA EMISSIONS					
L22	MX1	—	—	Std	—
LG3	MX1	Std	—	—	—
LM1	MX1	Std	—	—	G92
WITH NA6 HIGH ALTITUDE EMISSIONS					
LM1	MX1	—	—	—	Std

NOVA CUSTOM

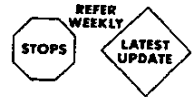

MODEL	
1XY27	Nova Custom Coupe
1XY69	Nova Custom 4-Door Sedan

MUST ORDER ONE: ENGINES

AVAILABLE WITH NA5 STANDARD EMISSION EQUIPMENT
 _____ L22 4.1 Litre 1 BBL L6 (Reqs MM3 or MX1 Trans)
 _____ LG3 5.0 Litre 2 BBL V8 (Reqs J50 Brakes and MM4 or MX1 Trans)

✓ **AVAILABLE WITH NA6 HIGH ALTITUDE EMISSION EQUIPMENT (Recommended Above 4000 Foot Altitude)**
 _____ LM1 5.7 Litre 4 BBL V8 (Reqs MX1 Trans and J50 Brakes)

CALIFORNIA EMISSION REQUIREMENTS (REQS YF5)
 _____ L22 4.1 Litre 1 BBL L6 (Reqs MX1 Trans)
 _____ LG3 5.0 Litre 2 BBL V8 (Reqs MX1 Trans and J50 Brakes)
 _____ LM1 5.7 Litre 4 BBL V8 (Reqs MX1 Trans and J50 Brakes)

QUICK-SPEC

IF TIRE AND/OR TRANSMISSION IN QUICK-SPEC IS NOT DESIRED YOU MUST "PLUS" ANOTHER TIRE AND/OR TRANSMISSION OPTION.	4	4	4	4	4
	8	8	8	8	8
	0	1	2	3	4
	A	A	A	A	A

Air Conditioning	C60	x	x	x	x	x
Brakes, Power	J50	x	x	x	x	x
Console (w/Bucket Seats) (1XY27 Only)	D55	x	x	x	x	x
Glass, Tinted	A01	x	x	x	x	x
Moldings, Body Side	B84	x	x	N/I	N/I	N/I
Radio, AM	U63	x	x	N/I	N/I	N/I
Steering, Power	N41	x	x	x	x	x
Tires, FR78-14/B White Stripe	QDW	x	x	x	x	x
Transmission, Automatic	MX1	x	x	x	x	x
Wheel Covers, Full	P01	x	x	N/I	N/I	N/I

Belts, Deluxe (w/o Black or White w/Black Trim)	AK1	x	x	x	x	x
Bumper Rub Strips and Guards	V30	x	x	x	x	x
Clock, Electric	U35	x	x	x	x	x
Lighting, Auxiliary	TR9	x	x	x	x	x
Mats, Color-Keyed Floor	B37	x	x	x	x	x
Mirror, LH Remote Control	D33	x	N/I	N/I	N/I	N/I
Moldings, Door Edge Guards	B93	x	x	x	x	x
Molding, Roof Drip	B80	x	x	x	x	x
Steering Wheel, Comfortilt	N33	x	x	x	x	x

Defogger, Rear Window	C50	x	x	x		
Mirrors, LH Remote and RH Manual Sport	D35	x	x	x		
Moldings, Body Side Deluxe	BW2	x	x	x		
Radio, AM/FM	U69	x	x	N/I		
Speaker, Rear Seat	U80	x	x	N/I		
Speed Control (w/MX1 Trans Only)	K30	x	x	x		
Wheels, Rally	ZJ7	x	x	x		

Door Lock System, Power	AU3		x	x		
Horns, Dual	U05		x	x		
Moldings, Side Window Reveal	B90		x	x		
Moldings, Wheel Opening	B96		x	N/I		
W/S Wiper System, Intermittent	CD4		x	x		

Moldings, Bright Rocker	B51				x	
Moldings, Wide Wheel Opening	B74				x	
Radio, AM-FM Stereo	U58				x	
Windows, Power	A31				x	
Windows, Swing-out Rear Side (1XY27 Only)	A20				x	

PLEASE REVIEW OPTION RESTRICTIONS BEFORE ORDERING

Q-S	OPTION	
480	C60	AIR CONDITIONING: (Incls V01 Rad w/L22 Eng)
	G92	AXLES, REAR — Performance Ratio (See Power Teams Chart)
	G80	— Limited Slip Differential
	UA1	BATTERY, HEAVY-DUTY
481	AK1	BELTS, DELUXE: Color-Keyed Seat and Shoulder (N/A Black or White w/Black Interior Trim)
480	J50	BRAKES, POWER
481	V30	BUMPER EQUIPMENT: Rub Strips and Guards, Front and Rear

PLEASE REVIEW OPTION RESTRICTIONS BEFORE ORDERING

Q-S	OPTION	
481	U35	CLOCK: Electric (N/A UY8 Radio) (Incl w/U14 Inst)
480	D55	CONSOLE: (1XY27 Only) (Reqs Bucket Seats) (N/A MM3 Trans)
482	C50	DEFOGGER, REAR WINDOW: Blower Type
483	AU3	DOOR LOCK SYSTEM, POWER EMISSION SYSTEMS: (Must Order Only One) (See Power Teams Chart)
	YF5	— California Emission Requirements
	NA6	— High Altitude Emission Equipment
	NA5	— Standard Emission Equipment
481	B37	FLOOR COVERING: Mats, Color-Keyed Floor, Front and Rear
	UF7	GAGE PACKAGE: (N/A U14 Inst)
480	A01	GLASS, TINTED: All Windows
483	U05	HORNS, DUAL
	U14	INSTRUMENTATION: Special (N/A UY8 Radio) (Incls U35 Clock)
481	TR9	LIGHTING, AUXILIARY MIRRORS:
	D33	— Outside Rearview, LH Remote Control
481	D33	— Sport, LH Remote and RH Manual
482	D35	MOLDINGS:
480	B84	— Body Side (N/A Z26 Rally)
482	BW2	— Body Side, Deluxe (N/A Z26 Rally) (Refer Page 6 for Standard Color Application)
484	B51	— Bright Rocker
481	B93	— Door Edge Guards
481	B80	— Roof Drip (Incl w/Vinyl Roof or ZJ5 App. Group)
483	B90	— Side Window Reveal (Incl w/ZJ5 App Group)
483	B96	— Wheel Opening (N/A Z26 Rally) (Incl ZJ5 App Group)
484	B74	— Wheel Opening, Wide (N/A ZJ5 App Group, B96 Midg, D85 Striping or Z26 Rally)
	B3W	PRELIMINARY PRICE INFORMATION
	V01	RADIATOR, HEAVY-DUTY: (Incl w/C60 Air w/L22 Eng)
		RADIO EQUIPMENT:
480	U63	— AM Radio
482	U69	— AM/FM Radio
484	U58	— AM/FM Stereo Radio
	UM1	— AM Radio w/8-Track Stereo Tape
	UM2	— AM/FM Stereo Radio w/8-Track Stereo Tape
	UN3	— AM/FM Stereo Radio w/Stereo Cassette Tape
	UY8	— AM/FM Stereo Radio w/Digital Clock Display (N/A U14 Inst or U35 Clock)
482	U80	— Speaker, Rear Seat (Reqs U63 or U69 Radio)
	U76	— Windshield Antenna (Incl w/Above Radio Equip)
	Z26	RALLY EQUIPMENT: (1XY27 Only) (N/A B84, BW2, B96 or B74 Midgs P01, N95 or ZJ7 Wheel Trim or Two-Tone Paint) (Refer Page 6 for Standard Stripe Color Application)
		ROOF COVER, VINYL: (See Vinyl Roof Chart)
		— Vinyl
	AB8	— Cabiolet (1XY27 Only) (Reqs Vinyl Roof Color Code) (N/A A20 Windows)
482	K30	SPEED CONTROL: Automatic (Reqs MX1 Trans and J50 Brakes)
480	N41	STEERING, POWER
481	N33	STEERING WHEEL: Comfortilt (N/A MM3 Trans)
	N65	STOWAWAY SPARE TIRE
	D85	STRIPING, PIN: Body Side (N/A Z26 Rally) (Refer Page 6 for Standard Stripe Color Application)
		SUSPENSION EQUIPMENT:
	F40	— Heavy Duty Front and Rear
	F41	— Sport (Reqs Radial Tires) (N/A L22 Eng or F40 Susp)
		TIRES: (B/W: Blackwall, W/S: White Stripe, W/L: White Lettered)
	QEG	— Bias Belted Ply (14/B)
	QEH	— E78 B/W (Base)
		— E78 W/S
		Steel Belted Radial Ply (14/B)
	QDV	— FR78 B/W
480	QDW	— FR78 W/S
	QBT	— FR78 W/L
		TRANSMISSIONS: (See Power Teams Chart)
	MM3	— 3-Speed Manual (N/A LM1 or LG3 Eng)
	MM4	— 4-Speed Manual (Reqs LG3 Eng)
480	MX1	— Automatic
	ZJ5	VALUE APPEARANCE GROUP: (N/A Z26 Rally) (Incls B80, B90 and B96 Midgs)
		WHEEL TRIM: (N/A Z26 Rally Equip)
480	P01	— Wheel Covers, Full
	N95	— Wheel Covers, Wire (Reqs Radial Tires)
482	ZJ7	— Wheels, Rally, Color-Keyed
		WINDOWS:
484	A31	— Power
484	A20	— Swing-Out Rear Side (1XY27 Only)
483	CD4	WINDSHIELD WIPER SYSTEM: Intermittent

VINYL ROOF SELECTION

Vinyl Roof	Code	Exterior Color Availability	
		Recommended	Acceptable
Beige	UU	61, 63 or 69	11 or 19
Black	BB	11, 15, 19, 24, 51, 61 or 75	22, 29, 40, 44, 63 or 77
Blue, Light (Met)	DD	11, 19, 22 or 29	
Carmine, Dark (Met)	RR	77	
Green, Light	GG	40 or 44	
Silver	QQ	15 or 19	24, 29 or 77
White	WW	All except 15	15

COLOR AND TRIM SELECTION

PLEASE NOTE: The exterior and interior combinations shown in the chart below and designated as recommended (R), represent the ideal combinations. Those that are shown as acceptable (A), are attractive, but less desirable than the recommended combinations. Orders for additional combinations may be submitted, provided the dealer checks the appropriate order form box (D60), as verification that the requested combination is definitely desired. CAUTION: Please utilize available color samples when ordering, especially when adding a third color element (Vinyl Top, Exterior Color, Interior Trim) in order to avoid undesirable combinations.

Seat, Headliner and Door Trim Color		Black	Blue	Camel	Carmine
Instrument Panel Pad and Carpet Color		Black	Blue	Camel	Carmine
MODEL	SEAT TYPE				
1XX27- 1XX69	Sport Cloth Bench		JDD1	JCC1	
	Vinyl Bench	VBB1	VDD1	VCC1	VRR1
1XX17	Vinyl Bench	VBB	VDD1	VCC1	VRR1

EXTERIOR PAINT COLOR	COLOR CODE			L	U	T	R	A	R	A	R
	L	U	T								
Beige	61	61	—				R		R		A
Black	19	19	—				R	R	R		R
Blue, Bright (Met)	24	24	11				R	A	A		
Blue, Dark (Met)	29	29	—				A	R	A		
Blue, Light (Met)	22	22	—				A	R			
Brown, Dark (Met)	69	69	61				A		R		
Camel (Met)	63	63	61				A		R		
Carmine (Met)	77	77	11				A		A		R
Green, Light	40	40	—				A		A		
Green, Medium (Met)	44	44	11				A		A		
Red	75	75	11				R		A		A
Silver	15	15	—				R	A			R
White	11	11	—				R	R	R		R
Yellow, Bright	51	51	—				R		A		

L = Lower U = Upper T = Two-Tone

POWER TEAMS

(Refer to next page for option availability and application)

ENGINE OPTION CONDITION	AXLE RATIO			
	2.41	2.56	2.73	3.08
WITHOUT YF5 CALIFORNIA OR NA6 HIGH ALTITUDE EMISSIONS.				
L22 MM3 or MX1	—	Std	—	—
LG3 MM4 MX1	— Std	— —	— —	Std G92
WITH YF5 CALIFORNIA EMISSIONS				
L22 MX1	—	—	Std	—
LG3 MX1	Std	—	—	—
LM1 MX1	Std	—	—	G92
WITH NA6 HIGH ALTITUDE EMISSIONS				
LM1 MX1	—	—	—	Std

NOVA

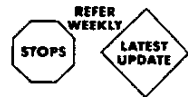

MODEL	
1XX17	Nova Hatchback Coupe
1XX27	Nova Coupe
1XX69	Nova 4-Door Sedan

MUST ORDER ONE: ENGINES

AVAILABLE WITH NA5 STANDARD EMISSION EQUIPMENT
 _____ L22 4.1 Litre 1 BBL L6 (Reqs MM3 or MX1 Trans)
 _____ LG3 5.0 Litre 2 BBL V8 (Reqs J50 Brakes and MM4 or MX1 Trans)

AVAILABLE WITH NA6 HIGH ALTITUDE EMISSION EQUIPMENT (Recommended Above 4000 Foot Altitude)
 _____ LM1 5.7 Litre 4 BBL V8 (Reqs MX1 Trans and J50 Brakes)

CALIFORNIA EMISSION REQUIREMENTS (REQS YF5)
 _____ L22 4.1 Litre 1 BBL L6 (Reqs MX1 Trans)
 _____ LG3 5.0 Litre 2 BBL V8 (Reqs MX1 Trans and J50 Brakes)
 _____ LM1 5.7 Litre 4 BBL V8 (Reqs MX1 Trans and J50 Brakes)

QUICK-SPEC

IF TIRE AND/OR TRANSMISSION IN QUICK-SPEC IS NOT DESIRED YOU MUST "PLUS" ANOTHER TIRE AND/OR TRANSMISSION OPTION.	4	4	4	4	4
	8	8	8	8	8
	5	6	7	8	9
	A	A	A	A	A

Brakes, Power	J50	x	x	x	x	x
Moldings, Body Side	B84	x	x	x	N/I	N/I
Radio, AM	U63	x	x	x	N/I	N/I
Steering, Power	N41	x	x	x	x	x
Tires, E78-14/B White Stripe	QEH	x	N/I	N/I	N/I	N/I
Transmission, Automatic	MX1	x	x	x	x	x
Wheel Covers, Full	PO1	x	x	N/I	N/I	N/I

Air Conditioning	C60	x	x	x	x
Defogger, Rear Window	C50	x	x	x	x
Glass, Tinted	A01	x	x	x	x
Interior Decor Package	ZJ3	x	x	x	x
Mirror, LH Remote Control	D33	x	N/I	N/I	N/I
Moldings, Roof Drip	B80	x	x	x	x
Tires, FR78-14/B White Stripe	QDW	x	x	x	x

Belts, Deluxe (w/o Black Trim)	AK1	x	x	x	
Bumper Rub Strips and Guards	V30	x	x	x	
Mats, Color-Keyed Floor	B37	x	x	x	
Mirrors, LH Remote and RH Manual Sport	D35	x	x	x	
Moldings, Wheel Opening	B96	x	x	x	N/I
Wheels, Rally	ZJ7	x	x	x	

Clock, Electric	U35		x	x	
Moldings, Body Side Deluxe	BW2		x	x	
Moldings, Door Edge Guard	B93		x	x	
Radio, AM/FM	U69		x	x	
Speaker, Rear Seat	U80		x	x	
Steering Wheel, Comfortilt	N33		x	x	

Horns, Dual	U05				x
Lighting, Auxiliary	TR9				x
Moldings, Bright Rocker	B51				x
Moldings, Wide Wheel Opening	B74				x
W/S Wiper System, Intermittent	CD4				x

PLEASE REVIEW OPTION RESTRICTIONS BEFORE ORDERING

Q-S	OPTION	
486	C60	AIR CONDITIONING: (Incls V01 Rad w/L22 Eng)
—	G92	— Performance Ratio (See Power Teams Chart)
—	G80	— Limited Slip Differential
—	UA1	BATTERY, HEAVY-DUTY
487	AK1	BELTS, DELUXE: Color-Keyed Seat and Shoulder (N/A Black Interior Trim)
485	J50	BRAKES, POWER
487	V30	BUMPER EQUIPMENT: Bumper Rub Strips and Guards Front and Rear
488	U35	CLOCK: Electric (N/A UY8 Radio) (Incl w/U14 Inst)

PLEASE REVIEW OPTION RESTRICTIONS BEFORE ORDERING

Q-S	OPTION	
486	C50	DEFOGGER, REAR WINDOW: Blower Type
—	AU3	DOOR LOCK SYSTEM, POWER
—	—	EMISSION SYSTEMS: (Must Order Only One) (See Power Teams)
—	YF5	— California Emission Requirements
—	NA6	— High Altitude Emission Equipment
—	NA5	— Standard Emission Equipment
487	B37	FLOOR COVERING: Mats, Color-Keyed Floor. Front and Rear
—	UF7	GAGE PACKAGE: (N/A U14 Inst)
486	A01	GLASS, TINTED: All Windows
489	U05	HORNS, DUAL
—	U14	INSTRUMENTATION: Special (N/A UY8 Radio) (Incls U35 Clock)
486	ZJ3	INTERIOR DECOR PACKAGE: (Incls D31 Mir)
489	TR9	LIGHTING, AUXILIARY
—	—	MIRRORS:
—	D31	— Inside Rearview, Day-Night (Incl w/ZJ3 Int Decor)
486	D33	— Outside Rearview, LH Remote Control
487	D35	— Sport, LH Remote and RH Manual
—	—	MOLDINGS:
485	B84	— Body Side (N/A Z26 Rally)
488	BW2	— Body Side, Deluxe (N/A Z26 Rally) (Refer Page 6 for Standard Color Application)
489	B51	— Bright Rocker
488	B93	— Door Edge Guard
486	B80	— Roof Drip (Incl w/Vinyl Roof and ZJ5 App Group)
—	B90	— Side Window Reveal (Incl w/ZJ5 App Group)
487	B96	— Wheel Opening (N/A Z26 Rally) (Incl w/ZJ5 App Group)
489	B74	— Wheel Opening, Wide (N/A ZJ5 App Group, B96 Midg, D85 Striping or Z26 Rally)
—	B3W	PRELIMINARY PRICE INFORMATION
—	V01	RADIATOR, HEAVY-DUTY (Incl w/C60 Air w/L22 Eng)
—	—	RADIO EQUIPMENT:
485	U63	— AM Radio
488	U69	— AM/FM Radio
—	U58	— AM/FM Stereo Radio
—	UM1	— AM Radio w/8-Track Stereo Tape
—	UM2	— AM/FM Stereo Radio w/8-Track Stereo Tape
—	UN3	— AM/FM Stereo Radio w/Stereo Cassette Tape
—	UY8	— AM/FM Stereo Radio w/Digital Clock Display (N/A U14 Inst or U35 Clock)
488	U80	— Speaker, Rear Seat (Reqs U63 or U69 Radio)
—	U76	— Windshield Antenna (Incl w/Above Radio Equip)
—	Z26	RALLY EQUIPMENT: (N/A 1XX69) (N/A B84, BW2, B96 or B74 Midgs, PO1, N95 or ZJ7 Wheel Trim or Two-Tone Paint) (Refer Page 6 for Standard Stripe Color Application)
—	—	ROOF COVER, VINYL: (See Vinyl Roof Chart)
—	—	— Vinyl
—	AB8	— Cabriolet (1XX27 Only) (Reqs Vinyl Roof Color Code) (N/A A20 Windows)
—	K30	SPEED CONTROL: Automatic (Reqs MX1 Trans and J50 Brakes)
485	N41	STEERING, POWER
488	N33	STEERING WHEEL: Comfortilt (N/A MM3 Trans)
—	N65	STOWAWAY SPARE TIRE: (Std on 1XX17)
—	D85	STRIPING, PIN: Body Side (N/A Z26 Rally) (Refer Page 6 for Standard Stripe Color Application)
—	—	SUSPENSION EQUIPMENT:
—	F40	— Heavy-Duty Front and Rear
—	F41	— Sport (Reqs Radial Tires) (N/A L22 Eng or F40 Susp)
—	—	TIRES: (B/W: Blackwall, W/S: White Stripe, W/L: White Lettered)
—	—	Bias Belted Ply (14/B)
—	QEG	— E78 B/W (Base)
485	QEH	— E78 W/S
—	—	Steel Belted Radial Ply (14/B)
—	QDV	— FR78 B/W
486	QDW	— FR78 W/S
—	QBT	— FR78 W/L
—	—	TRANSMISSIONS: (See Power Teams Chart)
—	MM3	— 3-Speed Manual (N/A LM1 or LG3 Eng.)
—	MM4	— 4-Speed Manual (Reqs LG3 Eng)
485	MX1	— Automatic
—	ZJ5	VALUE APPEARANCE GROUP: (N/A Z26 Rally) (Incls B80, B90 and B96 Midgs)
—	—	WHEEL TRIM: (N/A Z26 Rally Equip)
—	N95	— Wheel Covers, Wire (Reqs Radial Tires)
485	PO1	— Wheel Covers, Full
487	ZJ7	— Wheels, Rally. Color-Keyed
—	—	WINDOWS:
—	A31	— Power
—	A20	— Swing-Out Rear Side (1XX17-27 Only)
489	CD4	WINDSHIELD WIPER SYSTEM: Intermittent

BODY SIDE MOLDING AND STRIPE CHART

NOVA

#STANDARD MOLDING COLOR REQUIRES BW2

*STANDARD STRIPE REQUIRES D85

WITH VINYL ROOF

Exterior Paint Color and Code	Vinyl Roof Color						
	Black	Beige	Blue Light (Met)	Carmine Dark (Met)	Green Light	Silver	White
	BB	UU	DD	RR	GG	QQ	WW
Beige 61 Molding Stripe	Beige Gold	Beige Gold	‡	‡	‡	‡	Beige White
Black 19 Molding Stripe	Silver Gold	Beige Gold	Blue Blue	‡	‡	Silver Silver	Silver White
Blue, Bright (Met) 24 Molding Stripe	Silver Black	‡	‡	‡	‡	Silver Silver	Silver White
Blue, Dark (Met) 29 Molding Stripe	Silver Silver	‡	Blue Silver	‡	‡	Silver Silver	Silver White
Blue, Light (Met) 22 Molding Stripe	Silver Black	‡	Blue Blue	‡	‡	‡	Blue White
Brown, Dark (Met) 69 Molding Stripe	‡	Beige Gold	‡	‡	‡	‡	Beige White
Camel (Met) 63 Molding Stripe	Beige Gold	Beige Gold	‡	‡	‡	‡	Beige White
Carmine (Met) 77 Molding Stripe	Carmine Red	‡	‡	Carmine Red	‡	Silver Silver	Carmine White
Green, Light 40 Molding Stripe	Green Black	‡	‡	‡	Green Green	‡	Green Green
Green, Medium (Met) 44 Molding Stripe	Green Black	‡	‡	‡	Green Green	‡	Green White
Red 75 Molding Stripe	Carmine Black	‡	‡	‡	‡	‡	Carmine White
Silver 15 Molding Stripe	Silver Black	‡	‡	‡	‡	Silver Black	Silver White
White 11 Molding Stripe	Silver Black	Beige Gold	Blue Blue	‡	‡	‡	Beige Gold
Yellow, Bright 51 Molding Stripe	Silver Black	‡	‡	‡	‡	‡	Silver White

‡When D60 is specified to override Vinyl Roof and Exterior Color, Molding and Stripe Color is Silver on all combinations except 15 when the molding will be Silver and the stripe Black unless otherwise specified.

WITHOUT VINYL ROOF

Exterior Paint Color	Color Code			Molding B84	Stripe D85	Exterior Paint Color	Color Code			Molding B84	Stripe D85
	L	U	T				L	U	T		
Beige 61	61	—	—	Beige	Gold	Carmine (Met) 77	77	11	—	Carmine	Red
Black 19	19	—	—	Silver	Gold	Green, Light (Met) 40	40	—	—	Green	Green
Blue, Bright (Met) 24	24	11	—	Silver	Silver	Green, Medium (Met) 44	44	11	—	Green	Gold
Blue, Dark (Met) 29	29	—	—	Silver	Silver	Red 75	75	11	—	Carmine	Gold
Blue, Light (Met) 22	22	—	—	Blue	Blue	Silver 15	15	—	—	Silver	Red
Brown, Dark (Met) 69	69	61	—	Beige	Gold	White 11	11	—	—	Beige	Gold
Camel (Met) 63	63	61	—	Beige	Gold	Yellow, Bright 51	51	—	—	Silver	Orange

L = Lower U = Upper T = Two-Tone

PLEASE NOTE:

#If the color of the stripe (D85), as shown in the above charts, is not desired, order one of the following Options.

11A = White; 13A = Silver; 19A = Black; 27A = Light Blue; 49A = Light Green; 54A = Gold; 75A = Red; 80A = Orange

#If the color of molding (BW2), as shown in the above charts, is not desired, order one of the following Options.

15Q = Silver; 22Q = Light Blue; 40Q = Light Green; 61Q = Beige; 79Q = Dark Carmine

NOVA RALLY STRIPE CHART

The Exterior Paint and Interior Trim Combinations shown below are the only combinations that are available.

RPO Z26 (MUST BE SPECIFIED)	Interior Trim						
	Black	Blue	Camel	Carmine	White/Black	White/Blue	White/Carmine
Beige 61	Orange		Gold		Gold		
Black 19	Red	White	Gold	Red	White		Red
Blue, Bright (Met) 24	Black	White			Black	White	
Blue, Dark (Met) 29	Gold	White	Gold		White	White	
Blue, Light (Met) 22	Black	White			Black	White	
Brown, Dark (Met) 69	Orange		Gold		White		
Camel (Met) 63	Orange		Gold		White		
Carmine (Met) 77	Orange		Orange	Red	White		White
Green 40	Black		Gold		White		
Green, Light 44	Black		Gold		White		
Red 75	Orange		Orange	White	White		White
Silver 15	Black	Black		Red	Black		
White 11	Black	Black	Gold	Red	Black	Black	Red
Yellow, Bright 51	Black		Black		Black		

NOVA

1979 VEHICLES WITH STANDARD EQUIPMENT

Prices shown are effective with initial shipments of 1979 model motor vehicles

Description	Model Number	Body Code	Wheel Base	Dealer Invoice Amount*	Dealer Price	Factory D&H [‡]	List Price	Mfr's Suggested Retail Price*	Group Number
◆ 6-Cylinder Engine									
Nova									
Hatchback Coupe	1XX17	—	111"					4118.37	7
2-Door Coupe	1XX27	—	111"					3954.95	7
4-Door Sedan	1XX69	—	111"					4054.95	7
Nova Custom									
2-Door Custom Coupe	1XY27	—	111"					4163.95	7
Custom 4-Door Sedan	1XY69	—	111"					4263.95	7

★ Manufacturer's Suggested Retail Prices do not include applicable destination charges, state and local taxes, license fees, optional equipment or accessories or special items or services.
 ◆ Refer to Dealer Order Guide for California Requirements.

OPTIONS AND ACCESSORIES WHEN INSTALLED BY CHEVROLET

Prices shown are effective with initial shipments of 1979 model motor vehicles

Description	Option Number	Dealer Invoice Amount*	Dealer Price	Factory D&H [‡]	List Price	Mfr's Suggested Retail Price [◇]
REFER TO DEALER ORDER GUIDE FOR OPTION AVAILABILITY AND APPLICATION						
Interior Trim:						
V**1 Vinyl Bench Seat					NO ADDITIONAL CHARGE	
J**1 Sport Cloth Bench Seat						23.00
E**1 Custom Sport Cloth Bench Seat						23.00
X**1 Custom Vinyl Bench Seat					NO ADDITIONAL CHARGE	
X**2 Custom Vinyl Bucket Seats						85.00
Exterior Color:						
<i>Paint.</i>						
Solid					NO ADDITIONAL CHARGE	
Two-Tone. Includes bright metal outline moldings						55.00
<i>Roof Covers.</i>						
Vinyl. Includes bright roof drip moldings						99.00
Cabriolet	AB8					190.00
Engines: (Refer to Dealer Order Guide for Emission System Requirements)						
4.1 Litre 1 BBL L6	L22				NO ADDITIONAL CHARGE	
5.0 Litre 2 BBL V8	LG3					235.00
5.7 Litre 4 BBL V8	LM1					360.00
Air Conditioning: <i>Four-Season. includes increased cooling.</i>						
Without V8 engine. Also includes VO1 radiator	C60					562.00
With V8 engine	C60					529.00
Axles, Rear:						
Performance Ratio	G92					18.00
Limited Slip Differential	G80					64.00
Battery, Heavy-Duty	UA1					20.00
Belts, Deluxe: <i>Color-Keyed Seat and Shoulder.</i> Includes plastic buckles. (Standard belts and plastic buckles are black). Replacing standard number of belts.						
Coupes and Sedans with bench seat—6 seat and 2 front shoulder	AK1					23.00
Coupes with bucket seats—5 seat and 2 front shoulder	AK1					21.00
Brakes, Power	J50					76.00
Bumper Equipment: <i>Bumper Rub Strips and Guards.</i>						
Front and Rear. Includes black resilient impact strips	V30					79.00
Clock, Electric: Included with U14 Instrumentation	U35					23.00
Console	D55					80.00
Defogger, Rear Window: <i>Forced-Air.</i>	C50					55.00

* Dealer Invoice Amount includes Holdback Amount retained for dealer's account in accordance with Vehicle Terms of Sale Bulletin.
 ‡ Factory D & H Charges reflect provisions for pass through of tire weight tax imposed on manufacturer or importer of tires.
 ◇ State and local taxes not included.

NOVA

OPTIONS AND ACCESSORIES WHEN INSTALLED BY CHEVROLET

Prices shown are effective with initial shipments of 1979 model motor vehicles

Description	Option Number	Dealer Invoice Amount*	Dealer Price	Factory D&H [‡]	List Price	Mfr's Suggested Retail Price [◇]
REFER TO DEALER ORDER GUIDE FOR OPTION AVAILABILITY AND APPLICATION						
Door Lock System, Power: Electric						
Coupe.....	AU3					80.00
Sedan.....	AU3					111.00
Emission Systems:						
<i>California Emission Requirements.</i> Includes all testing, equipment and /or certification necessary for registration in the State of California.....						
	YF5					83.00
<i>High Altitude Emission Equipment</i>						
	NA6					35.00
<i>Standard Emission System</i>						
	NA5			NO ADDITIONAL CHARGE		
Floor Covering: Mats, Color-Keyed Floor. 2 front and 2 rear.						
	B37					23.00
Gage Package: Includes econominder, voltmeter and temperature gages.....						
	UF7					53.00
Glass, Tinted: All Windows						
	A01					64.00
Horns, Dual						
	U05					9.00
Instrumentation: Special. Includes U35 clock; tachometer, voltmeter and temperature gages located in instrument panel.....						
	U14					112.00
Interior Decor Package: Standard on Nova Custom. Includes D31 mirror, cigarette lighter, glove compartment light, right front door jamb dome light switch and additional bright framing on instrument cluster.....						
	ZJ3					31.00
Lighting, Auxiliary:						
<i>(A) Ashtray Light</i>						
<i>(B) Courtesy Lights</i>						
<i>(C) Glove Compartment Light</i>						
<i>(D) Luggage Compartment Light</i>						
<i>(E) Underhood Light</i>						
<i>(F) Headlight Warning Buzzer</i>						
<i>(G) Front Door Jamb Switch</i>						
<i>(H) Rear Door Jamb Switches</i>						
<i>(I) Rear Compartment Light Switch</i>						
Hatchback Coupe without ZJ3 Interior Decor Package. Includes A, B, C, E, F, G & I.....						
	TR9					43.00
Hatchback Coupe with ZJ3 Interior Decor Package. Includes A, B, E, F & I.....						
	TR9					31.00
2-Door Coupe without ZJ3 Interior Decor Package or Custom Interior. Includes A, B, C, D, E, F & G.....						
	TR9					43.00
2-Door Coupe with ZJ3 Interior Decor Package or Custom Interior. Includes A, B, D, E & F.....						
	TR9					31.00
4-Door Sedan without ZJ3 Interior Decor Package or Custom Interior. Includes A, B, C, D, E, F, G & H.....						
	TR9					48.00
4-Door Sedan with ZJ3 Interior Decor Package or Custom Interior. Includes A, B, D, E, F & H.....						
	TR9					36.00
Mirrors:						
<i>Inside Rearview, Day-Night.</i> Included with ZJ3 Interior Decor Package.....						
	D31					10.50
<i>Outside Rearview, LH Remote</i>						
	D33					18.00
<i>Sport, LH Remote and RH Manual</i>						
	D35					43.00
Moldings:						
<i>Body Side.</i> Includes black vinyl insert.....						
	B84					43.00
<i>Body Side, Deluxe</i>						
	BW2					53.00
<i>Bright Rocker and Extension</i>						
Without ZJ5 Value Appearance Group.....						
	B51					37.00
With ZJ5 Value Appearance Group.....						
	B51					15.00
<i>Door Edge Guard.</i>						
Coupes.....						
	B93					13.00
Sedans.....						
	B93					20.50
<i>Roof Drip.</i> Included with vinyl roof ZJ5 Value Appearance Group or two-tone paint.....						
	B80					20.00
<i>Side Window Reveal</i> Included with ZJ5 Value Appearance Group.....						
	B90					41.00
<i>Wheel Opening</i> Included with ZJ5 Value Appearance Group.....						
	B96					22.50
<i>Wide Wheel Opening</i>						
	B74					39.00

* Dealer Invoice Amount includes Holdback Amount retained for dealer's account in accordance with Vehicle Terms of Sale Bulletin.

‡ Factory D & H Charges reflect provisions for pass through of tire weight tax imposed on manufacturer or importer of tires.

◇ State and local taxes not included.

NOVA

OPTIONS AND ACCESSORIES WHEN INSTALLED BY CHEVROLET

Prices shown are effective with initial shipments of 1979 model motor vehicles

Description	Option Number	Dealer Invoice Amount*	Dealer Price	Factory D&H†	List Price	Mfr's Suggested Retail Price◇
REFER TO DEALER ORDER GUIDE FOR OPTION AVAILABILITY AND APPLICATION						
Radiator, Heavy-Duty: Included with C60 air conditioning with L22 4.1 Litre 1 BBL engine	V01					33.00
Radio Equipment:						
AM Radio	U63					82.00
AM /FM Radio	U69					158.00
AM /FM Stereo Radio	U58					232.00
AM Radio with Stereo Tape System	UM1					244.00
AM Radio with 8 Track Stereo Tape System	UM2					335.00
AM /FM Stereo Radio with 8 Track Stereo Tape System	UN3					341.00
AM /FM Stereo Radio with Digital Clock display	UY8					395.00
Speaker, Rear Seat	U80					25.00
Windshield Antenna. Included with radio	U76					27.00
Rally Equipment, Nova: Includes lower body side and over wheel opening striping, parking lamp accent, black painted headlamp bezels, Nova Rally nameplates, 14" x 6" or 14" x 7" rally wheels painted to match body /striping color with bright center hubs and wheel trim rings. Also includes rear end panel striping on 1XX17 and 1XX27 models	Z28					211.00
Speed Control: Automatic.	K30					103.00
Steering, Power	N41					163.00
Steering Wheel: Comfortilt.	N33					75.00
Stowaway Spare: Standard on Hatchback Coupe.	N65					19.30
Striping, Pin: Body Side	D85					30.00
Suspensions:						
Heavy-Duty Front and Rear. Includes special front stabilizer, front and rear springs and matching rear shock absorbers. Without V8 engine	F40					36.00
Without N41 steering or steel belted radial ply tires	F40					11.00
With N41 steering or steel belted radial ply tires	F40					11.00
Sport. Includes rear stabilizer, special front stabilizer, special front and rear shock absorbers and 14" x 7" wheels.	F41					45.00
Tires:						
E78-14 /B Bias Belted Ply Blackwall (Standard)	QEG				NO ADDITIONAL CHARGE	
E78-14 /B Bias Belted Ply White Stripe						
2-Door Coupe and Sedan						
Without N65 stowaway spare	QEH					47.00
With N65 stowaway spare	QEH					38.00
Hatchback Coupe	QEH					38.00
FR78-14 /B Steel Belted Radial Ply Blackwall						
2-Door Coupe or Sedan						
Without N65 stowaway spare	QDV					118.95
With N65 stowaway spare	QDV					95.56
Hatchback Coupe	QDV					95.56
FR78-14 /B Steel Belted Radial Ply White Stripe						
2-Door Coupe and Sedan						
Without N65 stowaway spare	QDW					167.95
With N65 stowaway spare	QDW					134.56
Hatchback Coupe	QDW					134.56
FR78-14 /B Steel Belted Radial Ply White Lettered						
2-Door Coupe and Sedan						
Without N65 stowaway spare	QBT					183.95
With N65 stowaway spare	QBT					147.56
Hatchback Coupe	QBT					147.56
Transmissions:						
3-Speed Manual	MM3				NO ADDITIONAL CHARGE	
4-Speed Manual	MM4					135.00
Automatic	MX1					335.00
Value Appearance Group Includes B80 roof drip, B90 side windows reveal, B96 wheel opening molding and Rocker Panel Moldings	ZJ5					79.00

* Dealer Invoice Amount includes Holdback Amount retained for dealer's account in accordance with Vehicle Terms of Sale Bulletin.
 † Factory D & H Charges reflect provisions for pass through of tire weight tax imposed on manufacturer or importer of tires.
 ◇ State and local taxes not included.

NOVA

OPTIONS AND ACCESSORIES WHEN INSTALLED BY CHEVROLET

Prices shown are effective with initial shipments of 1979 model motor vehicles

Description	Option Number	Dealer Invoice Amount*	Dealer Price	Factory D&H [§]	List Price	Mfr's Suggested Retail Price◇
REFER TO DEALER ORDER GUIDE FOR OPTION AVAILABILITY AND APPLICATION						
Wheel Trim:						
Wheel Covers, Full.....	P01					43.00
Wheel Covers, Wire.....	N95					130.00
Wheels, Rally. Includes special wheels and center caps, bright lug nuts.....	ZJ7					88.00
Windows:						
<i>Power, Electric</i>						
Coupe.....	A31					126.00
Sedan.....	A31					178.00
Swing-Out Rear Side.....	A20					59.00
Windshield Wiper System: Intermittent.....	CD4					38.00

* Dealer Invoice Amount includes Holdback Amount retained for dealer's account in accordance with Vehicle Terms of Sale Bulletin.
 § Factory D & H Charges reflect provisions for pass through of tire weight tax imposed on manufacturer or importer of tires.
 ◇ State and local taxes not included.

1979 NOVA

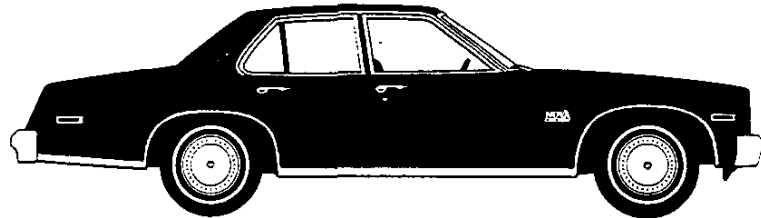

Nova Custom 4-Door Sedan

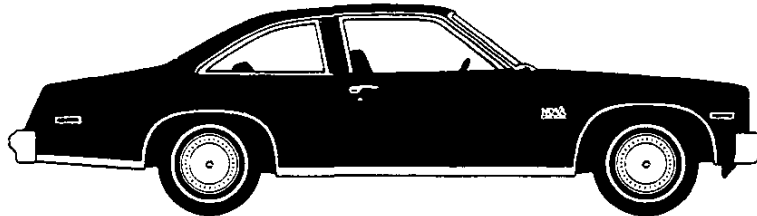

Nova Custom Coupe

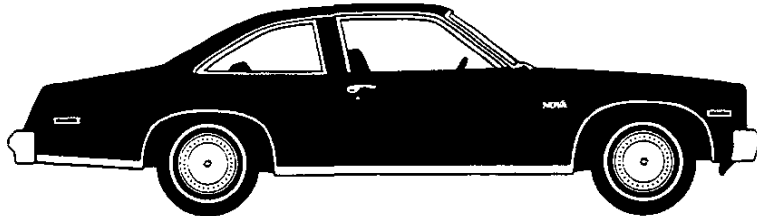

Nova Hatchback Coupe

Nova Custom	Model No.	Nova	Model No.
Coupe	1XY27	Hatchback Coupe	1XX17
4-Door Sedan	1XY69	Coupe	1XX27
		4-Door Sedan	1XX69

Index

Nova Value Features for 1979	2-5	Available Options	16-17
Nova Custom Sedan/Coupe Features	6	Power Teams	18
Nova Sedan/Coupe Features	7	Body Chassis Features	19
Nova Hatchback Coupe Features	8	Sound Deadening Features	20
Nova Rally Equipment	9	Anti-Corrosion Features	21
Interior Features	10-11	Equipment Summary	22-23
Instrument Panel Features	12	Dimensions/Specifications	24
Exterior Decor	13	Color & Trim Selections	25-29
Deluxe Body Side Molding, Pin Striping and Rally Striping Color Combinations	14-15		

Also see Value Features section for additional details.

See Dealer Order Guide for latest available information.

Nova/I

NOVA VALUE FEATURES FOR 1979

New Features for 1979 shown in Bold Face

ENGINE/CHASSIS

- 4.1 Litre 1-Bbl. L6 engine *standard*
- Three-speed manual transmission *standard*. See Power Teams for availability
- **New improved exhaust gas recirculation (EGR) and cold trapped spark control system for the 5.0 Litre V8 engine (49 states application) contribute to good drivability**
- Front disc/rear drum brake system *standard*
- Disc brake audible wear sensors to let you know when linings need replacing *standard*
- Delco Freedom battery never needs refilling. Sealed side terminals help prevent corrosion buildup *standard*
- Delcotron generator with built-in solid-state regulator *standard*
- Long recommended service intervals for oil change, oil filter, spark plugs, chassis lubrication and available automatic transmission fluid
- Separate front stub frame unit cushion-mounted to body
- Visible ball joint wear indicators on front suspension lower control arms for quick and easy wear inspection *standard*
- 21-gallon fuel tank

- High Energy Ignition system *standard*
- Coolant recovery system helps prevent costly coolant loss *standard*
- Single exhaust system
- E78-14 bias belted blackwall tires *standard*
- Early Fuel Evaporation system on all engines for quick warm-up
- Computer selected front coil springs with multi-leaf rear springs for smoothed out ride *standard*
- Bias-mounted rear shock absorbers *standard*
- Ball-race steering with forward-mounted linkage *standard*

BODY

- Body By Fisher
- **New front styling for all models features new bright grille, single-unit rectangular headlights with bright bezels plus new bright hood and fender extension moldings on Nova models**
- **New rear styling for Nova Custom models features bright accented double-unit taillights**
- Antenna built into windshield (included with available factory-installed radio) for protection against vandalism
- Double-panel door, hood and deck lid construction *standard*
- Flow-through ventilation

system for passenger comfort *standard*

- Hatchback Coupe features swing-up rear hatch and folding rear seat for roomy load area
- Counter-balanced rear deck lid on hatchback models
- Inner fenders front and rear for corrosion protection *standard*

INTERIOR

- Molded full foam seat construction *standard*
- Convenient single-retractor front seat belt system for outboard occupants
- Color-keyed cut-pile carpeting *standard*
- Day/night rearview mirror *standard* on Nova Custom
- Glove compartment lock *standard*
- Glove compartment light *standard* on Nova Custom
- **Improved anti-theft steering column lock *standard***

NEW OPTIONS

- Delco AM/FM Stereo Radio with Stereo Cassette Tape
- Delco AM/FM Stereo Radio with Digital Clock Display
- Value Appearance Group

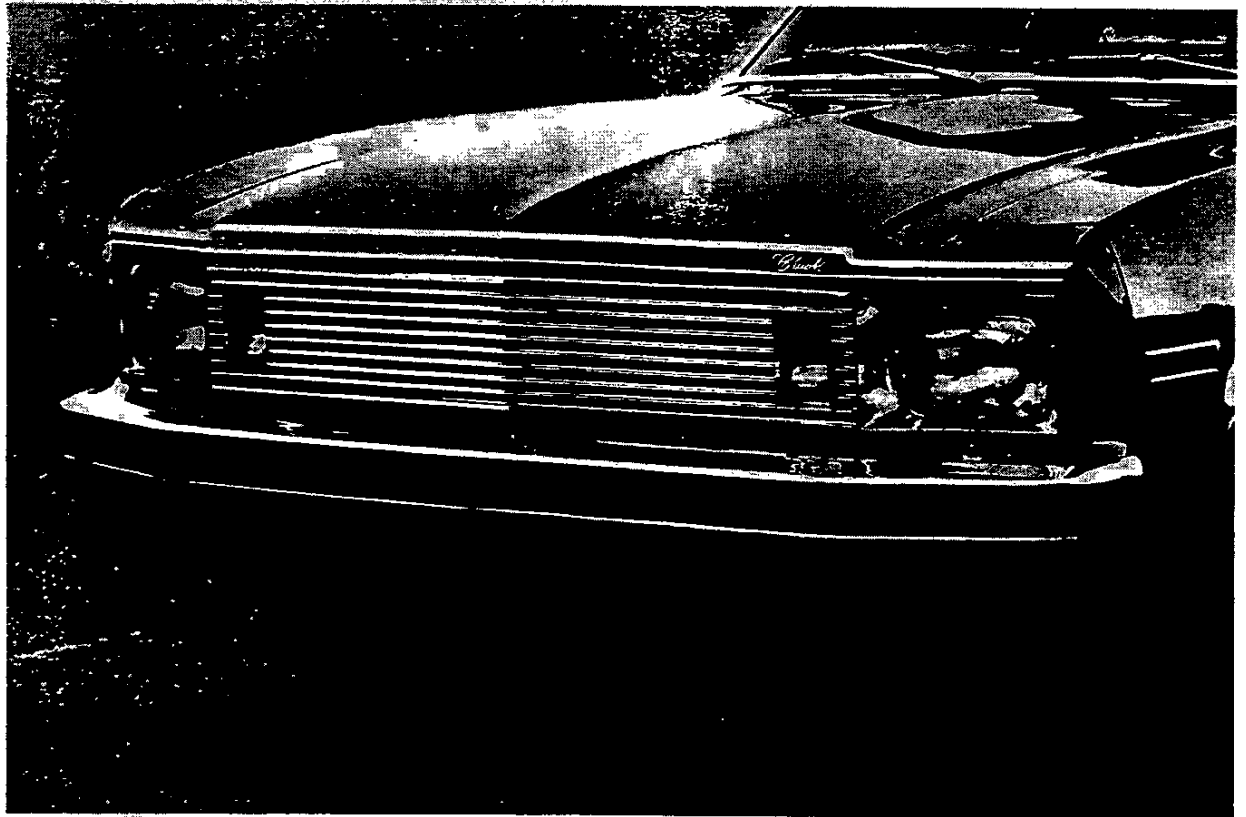

New Nova/Nova Custom Grille Featuring Hood and Fender Extension Moldings



New Nova Custom Double-Unit Taillights

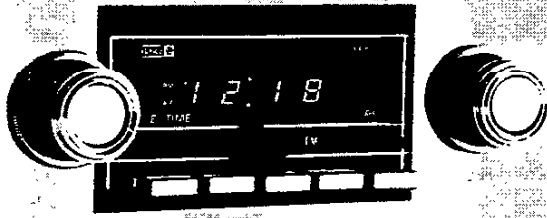

Available Delco AM/FM Stereo Radio with Digital Clock Display



Available AM/FM Stereo Radio

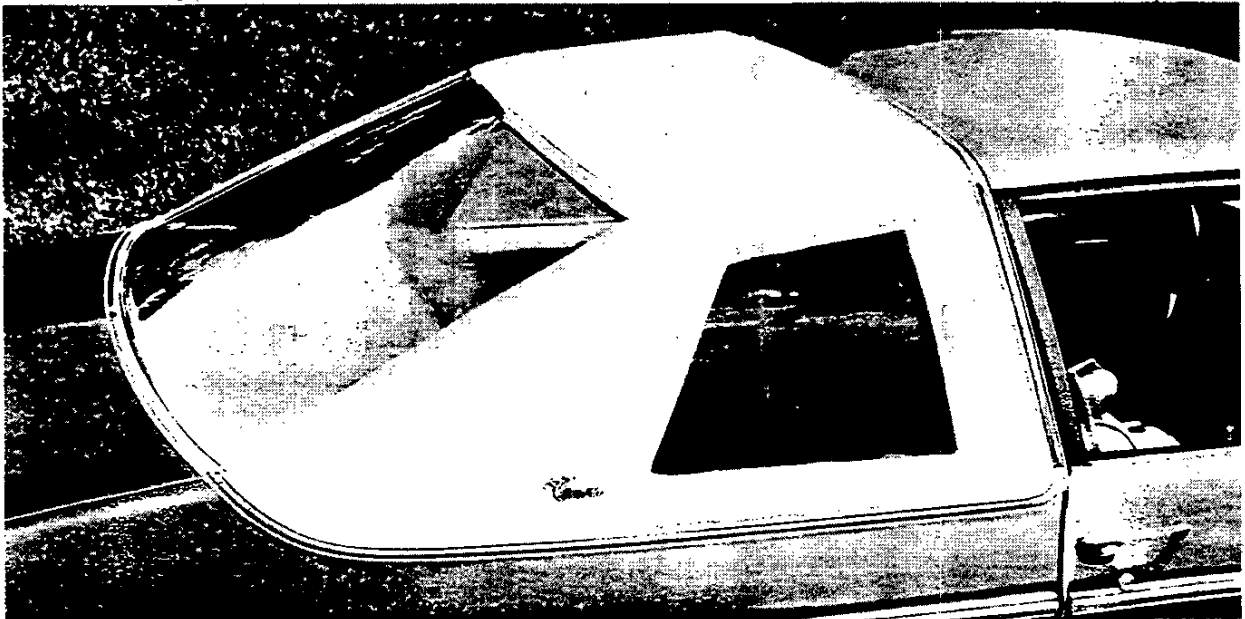

Available Cabriolet Roof Cover for Nova Coupe

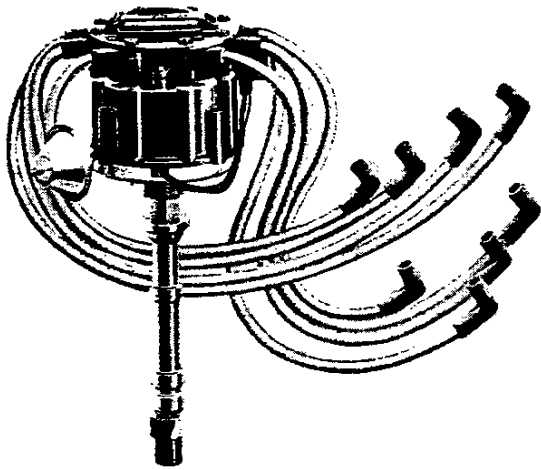

High Energy Ignition System *Standard*

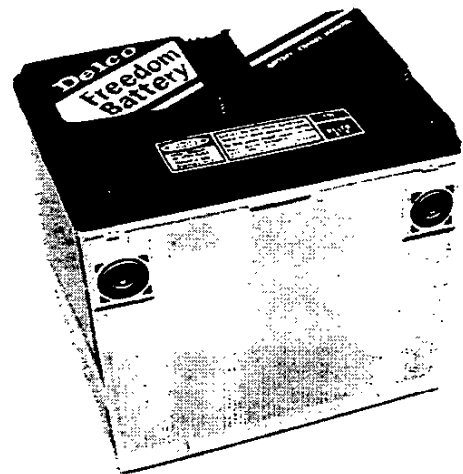

Delco Freedom Battery *Standard*

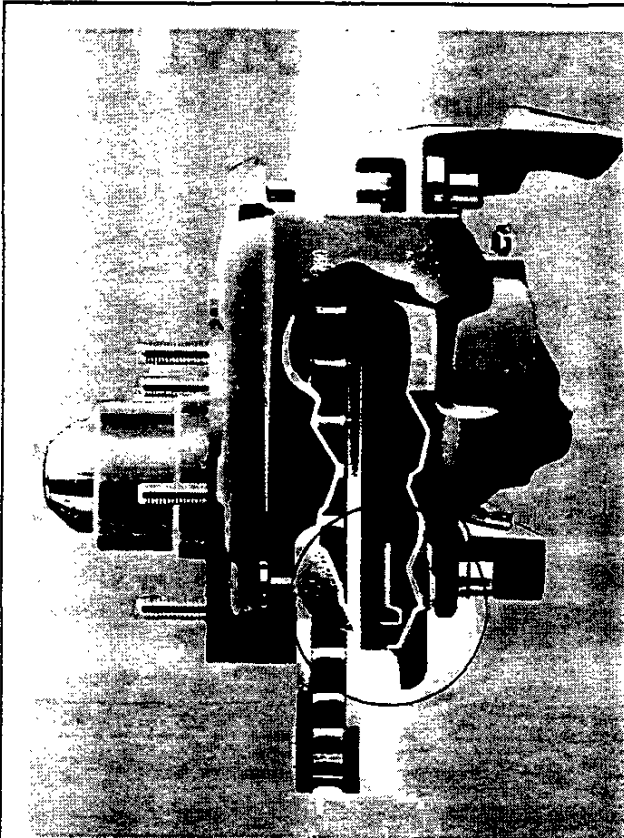

Front Disc Brake with Audible Wear Sensor *Standard*

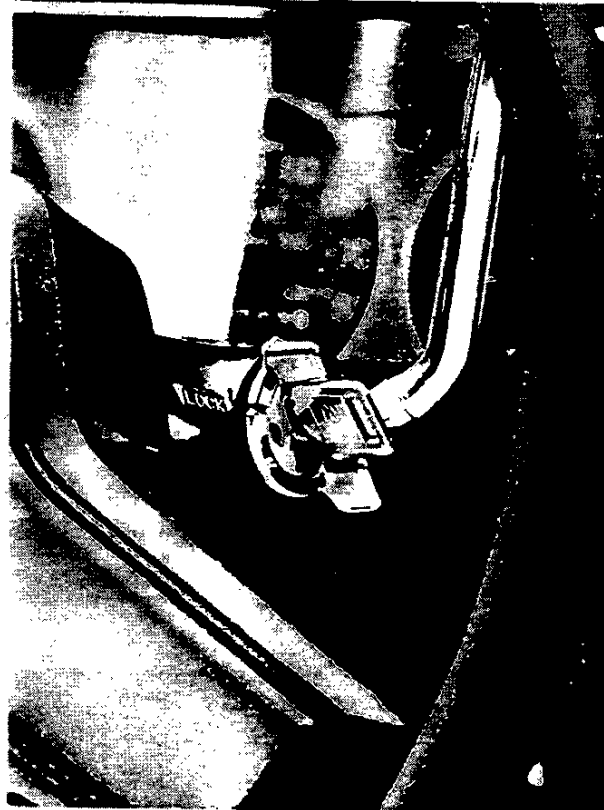

Improved Anti-Theft Steering Column Lock

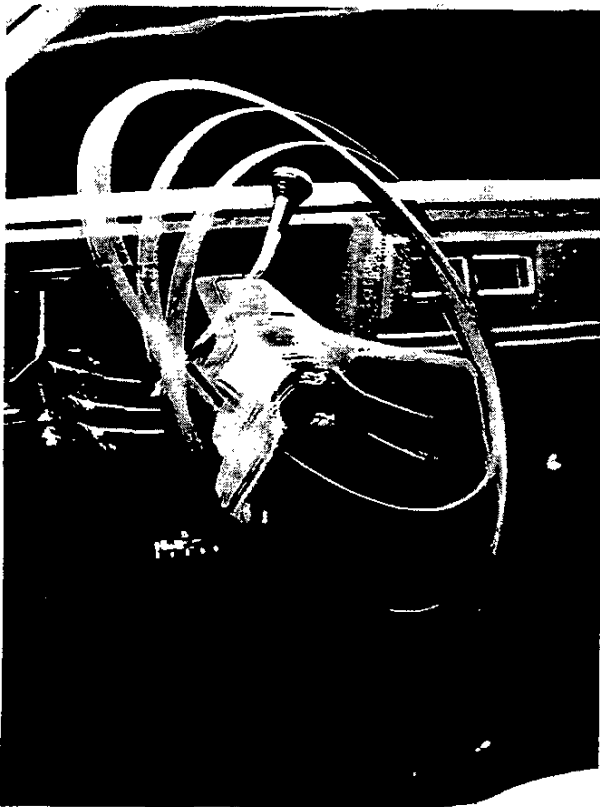

Available Comfortilt Steering Wheel

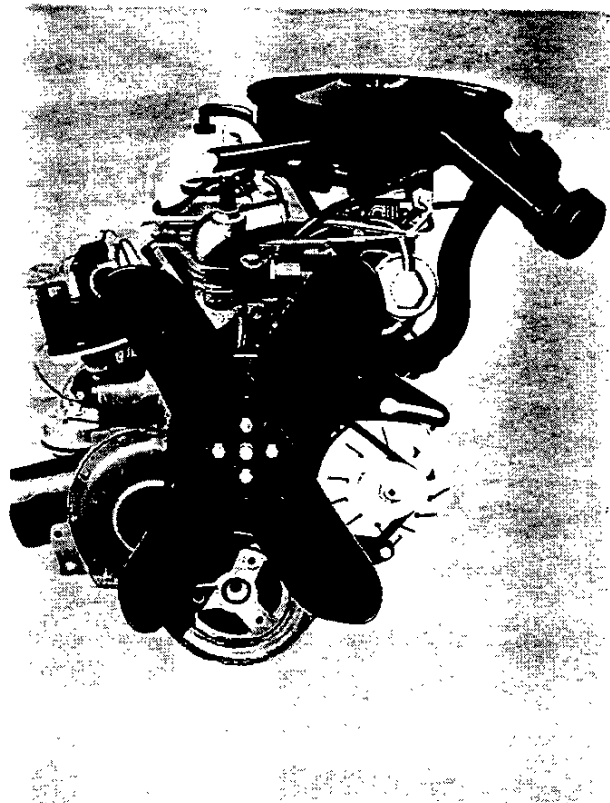

4.1 Litre 1-Bbl. L6 Engine *Standard*

NOVA CUSTOM

Sedan and Coupe

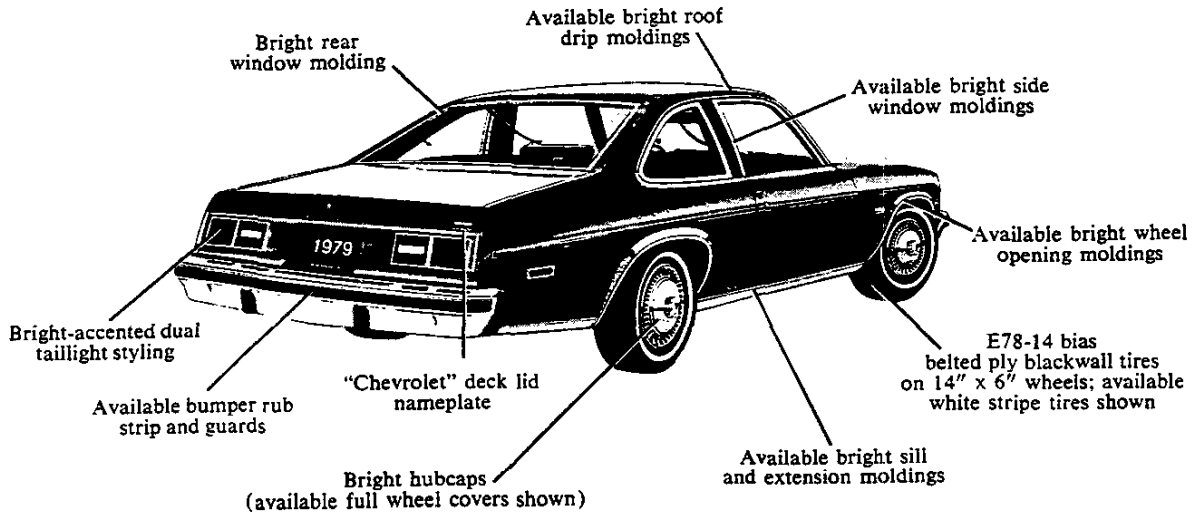
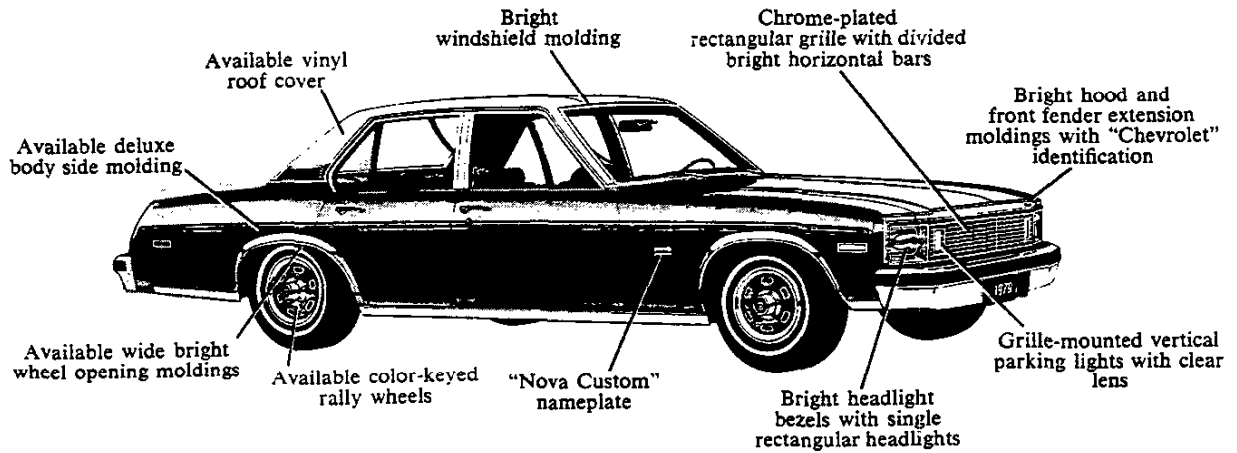

Standard Nova Hubcap

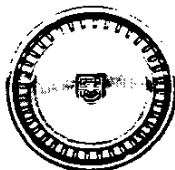

Available Full Wheel Covers (RPO PO1)

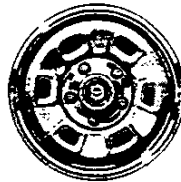

Available Color-Keyed Rally Wheels (RPO Z17)

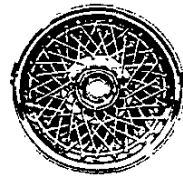

Available Wire Wheel Covers (RPO N95)

NOVA

Sedan and Coupe

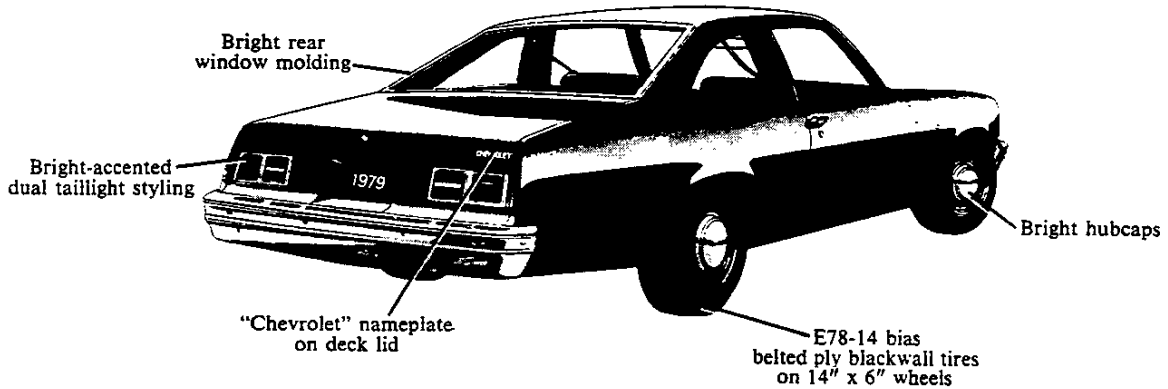
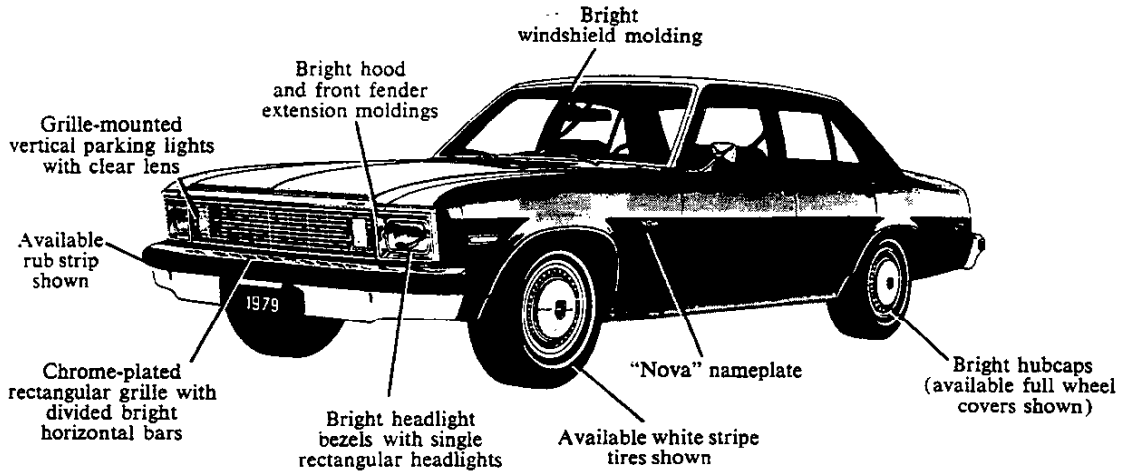

Standard
Nova Hubcap

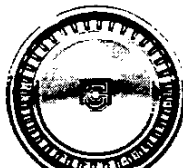

Available Full
Wheel Covers (RPO PO1)

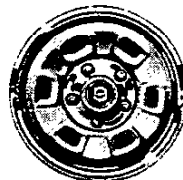

Available Color-Keyed
Rally Wheels
(RPO ZJ7)

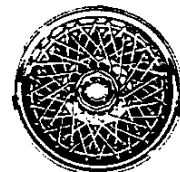

Available Wire
Wheel Covers (RPO N95)

NOVA

Hatchback Coupe

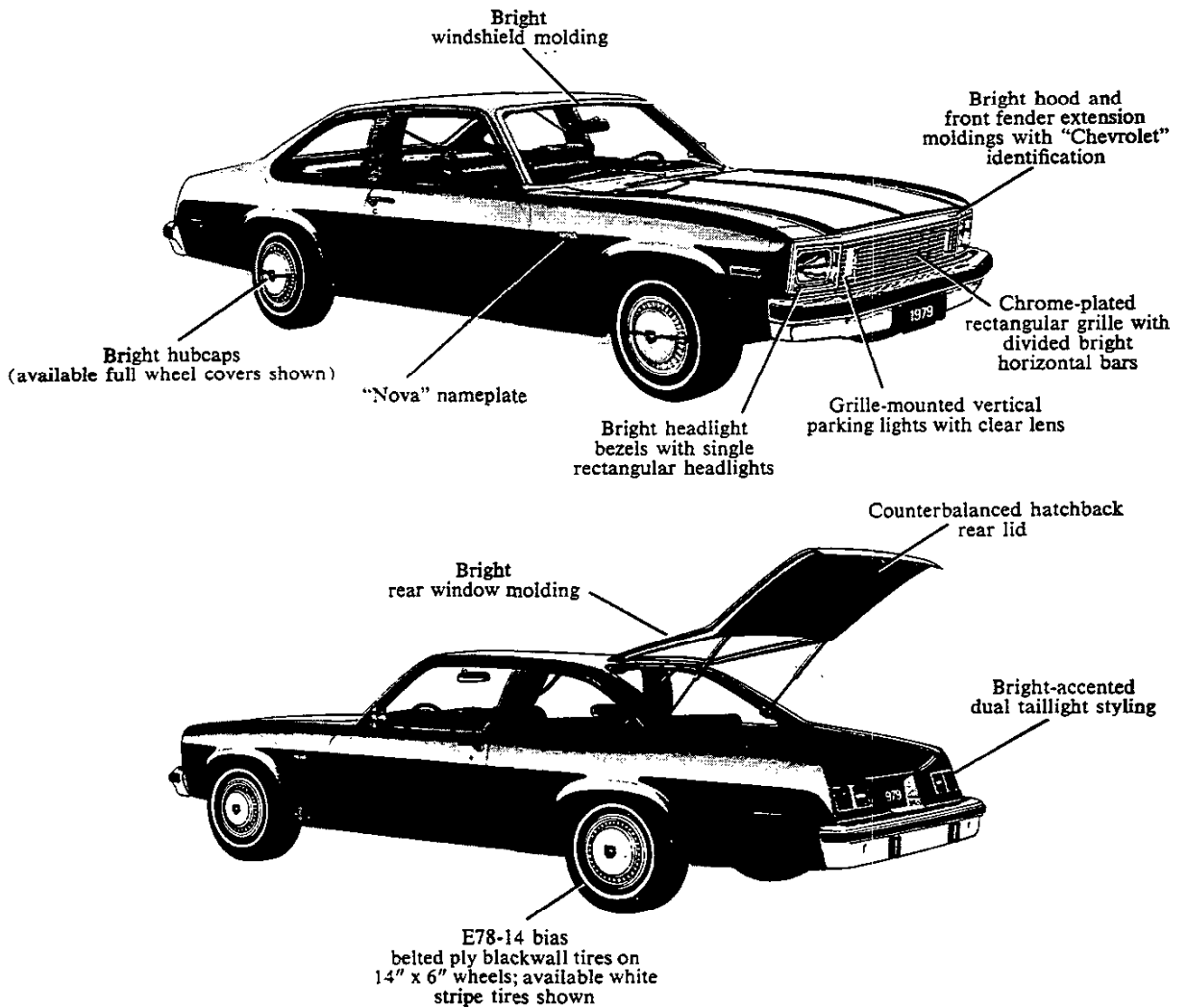

Standard Nova Hubcap

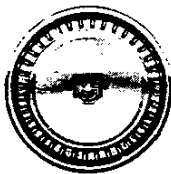

Available Full Wheel Covers (RPO PO1)

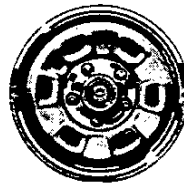

Available Color-Keyed Rally Wheels (RPO Z17)

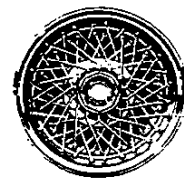

Available Wire Wheel Covers (RPO N95)

NOVA RALLY

Hatchback and Coupe

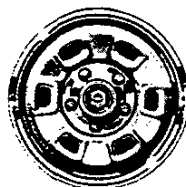
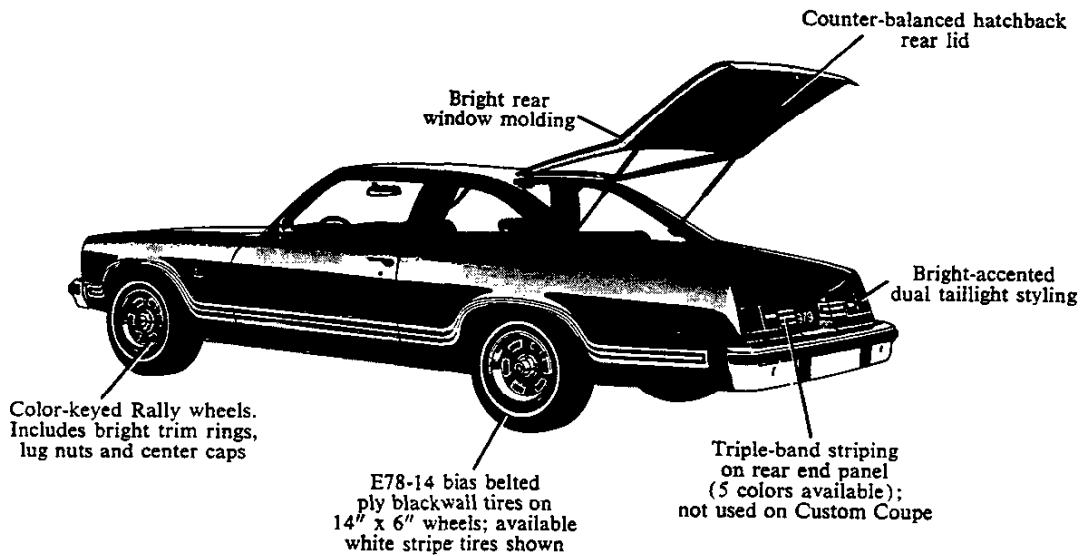
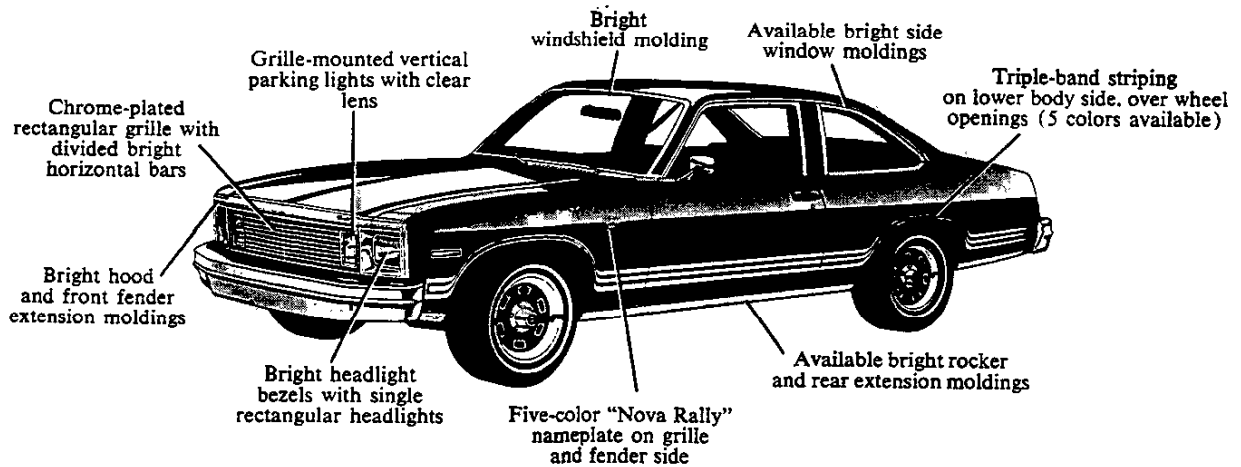

Standard Color-Keyed Rally Wheel

INTERIOR FEATURES

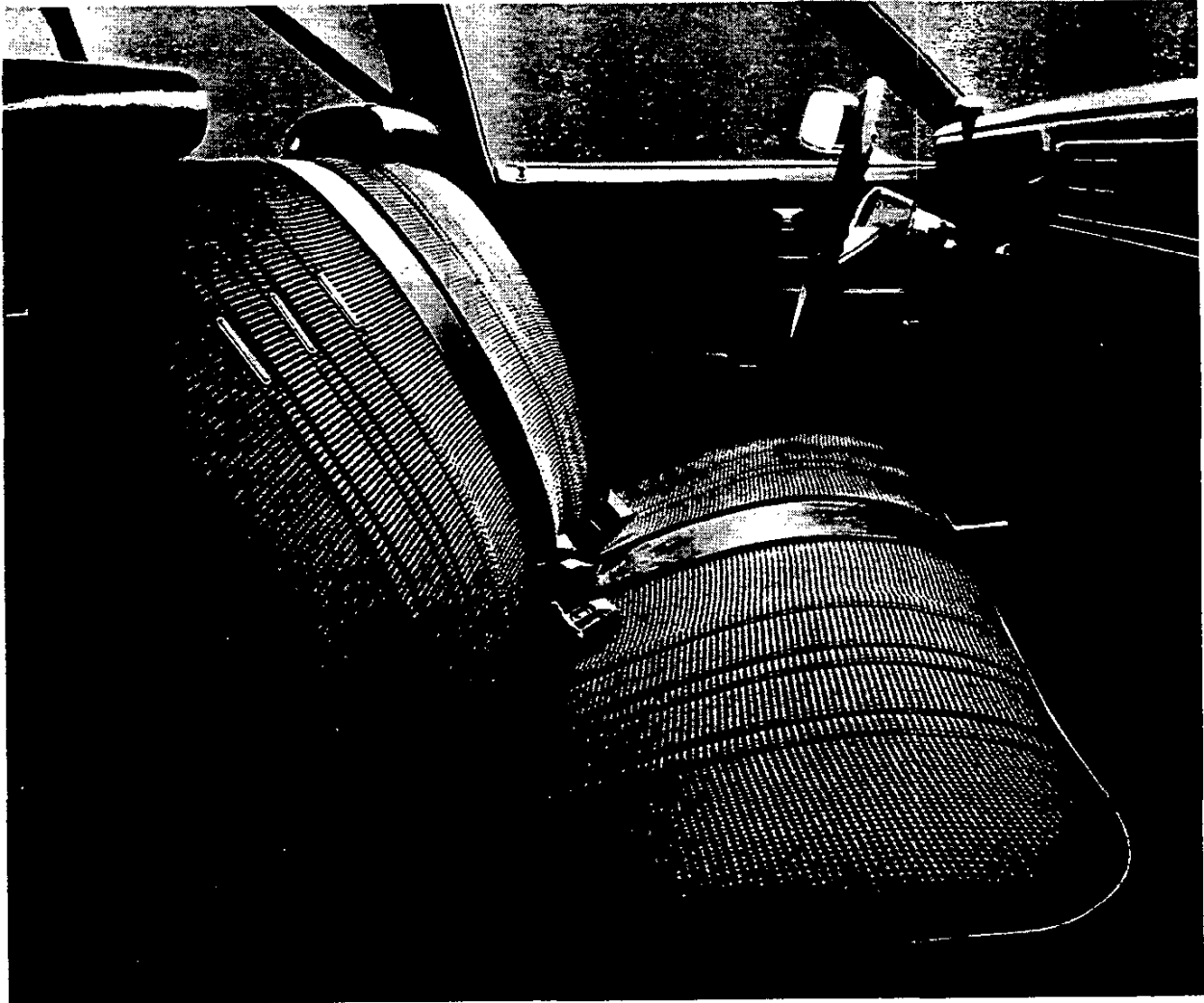

Nova Custom With Available Sport Cloth Interior

INTERIOR FEATURES	Nova Custom	Nova
Conventional full-width front seat	S	S
Custom interior seat and sidewall trim	S	NA
Simulated wood-grain strip on door trim panels	S	NA
Center dome light with bright bezel	S	S
Passenger door dome light switch	S	EC
Day night inside rearview mirror	S	EC
Cloth covered headlining	S	NA
Perforated hardboard formed headlining	NA	S
Front door padded armrest with integral door pull handle	S	S
Folding rear seat with standard vinyl trim (Hatchback only)	—	S
Rear compartment ashtrays	S	NA
Colored-keyed cut-pile carpeting	S	S
Luggage compartment mat	S	S
Color-keyed load floor carpet (Hatchback only)	—	S

S—Standard EC—Extra Cost NA—Not Available

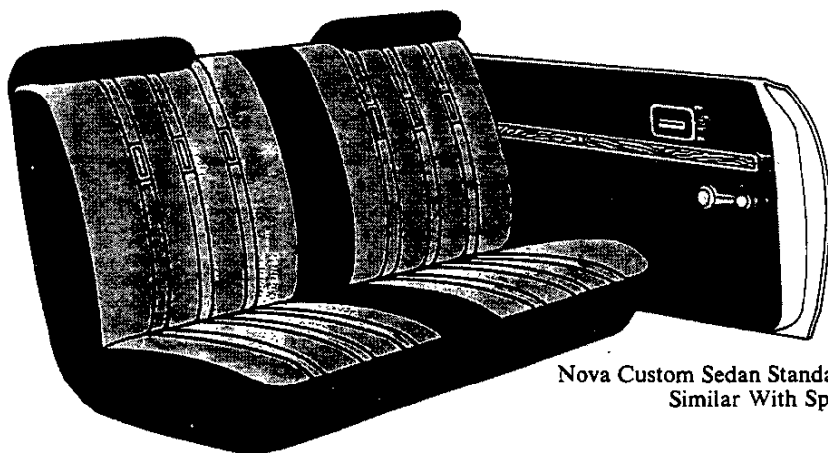

Nova Custom Sedan Standard Bench Seat Interior (Custom Coupe Similar With Split-Back Front Seat Design)

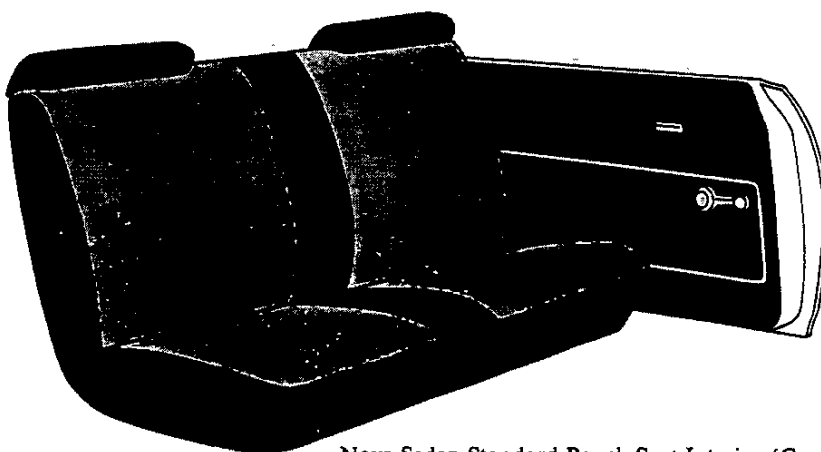

Nova Sedan Standard Bench Seat Interior (Coupes Similar With Split-Back Front Seat Design)

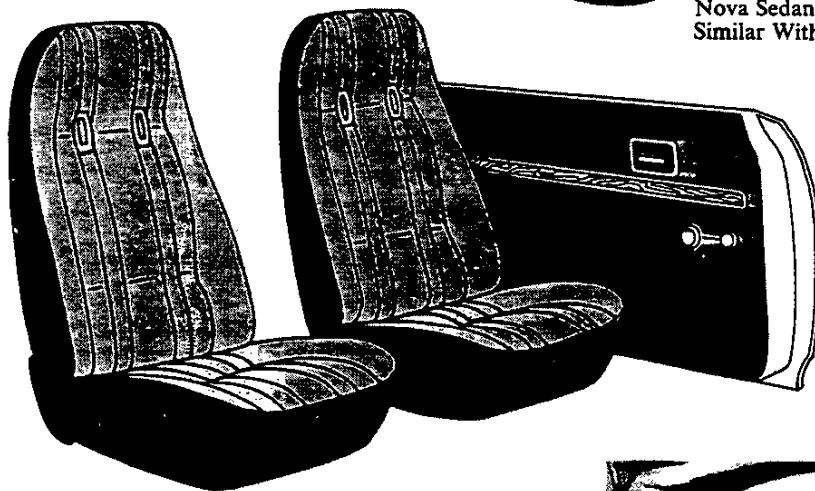

Nova Custom Coupe Available Bucket Seat Interior

NOTE: Illustrations show basic seat and door trim panel styling only. Shaded areas differentiate usage of cloth and vinyl trim materials. See Color & Trim Section for available exterior/interior color and trim selections.

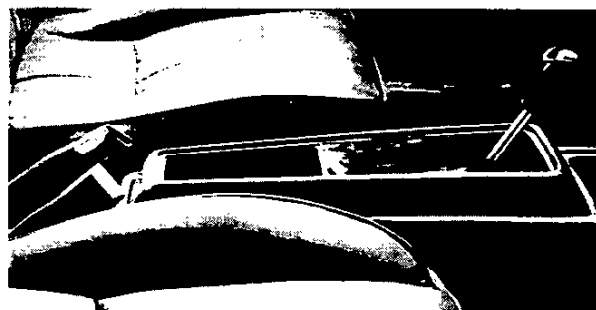

Console (RPO D55) Available For Nova Custom Coupe With Bucket Seats

NOVA INSTRUMENT PANEL

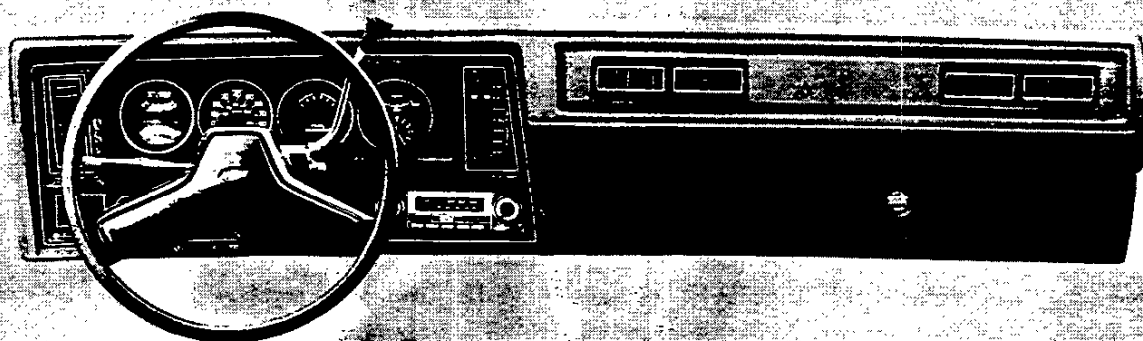

Nova Custom Instrument Panel

INSTRUMENT PANEL FEATURES	Nova Custom	Nova
Color-keyed instrument panel	S	S
Black instrument cluster panel	NA	S
Round instrumentation with simulated wood-grain panel	S	NA
80 mph/130 kph (kilometers per hour) speedometer	S	S
Black soft-rim steering wheel with Chevrolet emblem	S	S
Cigarette lighter	S	EC
Electric clock	EC	EC
Glove compartment lock	S	S
Glove compartment light	S	EC
Two-speed windshield wiper/washer illuminated control	S	S
Temperature, generator, oil pressure and brake warning lights	S	S
Intermittent windshield wipers	EC	EC
Automatic Speed control	EC	EC
Gage package includes: Econominder, voltmeter and temperature gages	EC	EC

S—Standard; NA—Not Available; EC—Extra Cost

EXTERIOR DECOR

Vinyl Roof Covers

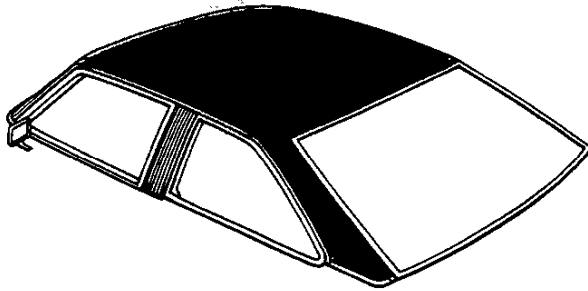

Full roof cover for all models. Available in Levant grain vinyl in seven colors. Coupe roof cover shown.

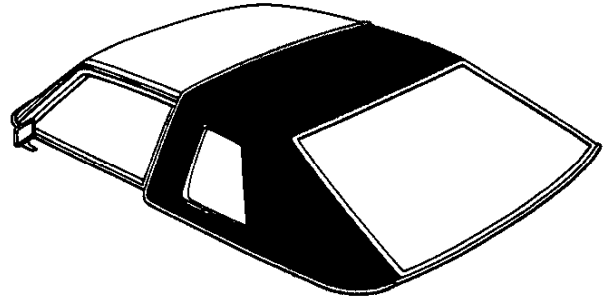

Cabriolet roof cover for Nova Custom and Nova Coupes. Available in Elk grain vinyl in seven colors.

VINYL ROOF COLOR SELECTIONS

VINYL ROOF	CODE	EXTERIOR COLOR AVAILABILITY
Beige	UU	Beige, Camel Metallic, Dark Brown Metallic, White or Black
Black	BB	All colors except Dark Brown Metallic
Light Blue Metallic	DD	White, Black, Light Blue Metallic or Dark Blue Metallic
Dark Carmine Metallic	RR	Carmine Metallic only
Light Green	GG	Light Green or Medium Green Metallic
Silver	QQ	Silver, Black, Bright Blue Metallic, Dark Blue Metallic or Carmine Metallic
White	WW	All colors

NOTE: Also see Color and Trim Section for additional details.

BRIGHT ROOF DRIP MOLDINGS (RPO B80)—Included with Value Appearance Group (RPO ZJ5), Two-Tone Finish or Vinyl Roof Cover.

BODY SIDE MOLDINGS (RPO B84)—Bright with black vinyl insert. Not available with Rally Equipment (RPO Z26). *Note: Color-keyed Deluxe Body Side Moldings (RPO BW2) shown on page 14.*

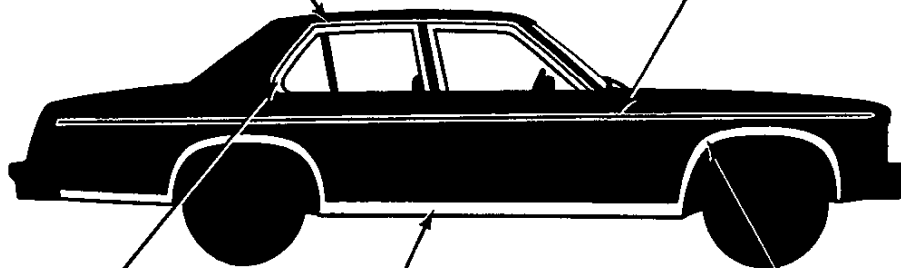

BRIGHT SIDE WINDOW REVEAL MOLDINGS (RPO B90)—Included with Value Appearance Package (RPO ZJ5).

BRIGHT ROCKER MOLDINGS (RPO B51)—Includes rear quarter panel extensions. Also included with Value Appearance Group (RPO ZU5) without rear quarter panel extensions.

WIDE WHEEL OPENING MOLDINGS (RPO B74) shown. Not available with Value Appearance Group (RPO ZJ5), Rally Equipment (RPO Z26) or Body Side Pin Striping (RPO D85). **Narrow WHEEL OPENING MOLDINGS (RPO B96)** also available. Included with Value Appearance Group (RPO ZJ5); not available with Rally Equipment (RPO Z26).

See Dealer Order Guide for latest available information.

Nova/13

Deluxe Body Side Moldings

(RPO BW2)

Bright body side moldings with vinyl insert available for all models. Vinyl insert is color-keyed to exterior and/or vinyl roof colors in Beige, Blue, Silver, Carmine or Green (shown). Not available with Rally Equipment (RPO Z26). See charts on page 15 for availability.

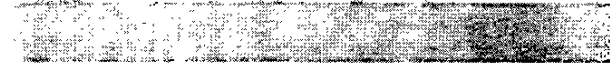

Beige



Carmine

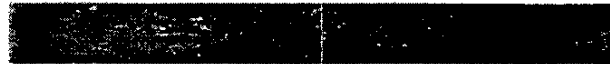

Blue



Green



Silver

Pin Striping (RPO D85)

Dual full-length pin striping accenting body sides along lower body and over wheel openings. Available in eight choices (shown) color-keyed to exterior and/or vinyl roof colors; Gold, Blue, Silver, White, Black, Red, Orange or Green. Not available with Rally Equipment (RPO Z26). See charts on page 15 for availability.

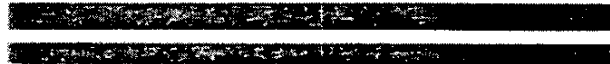
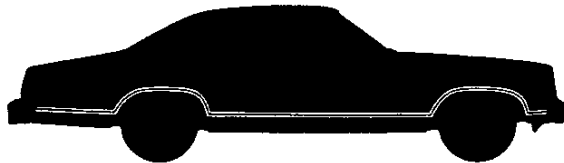

Gold



Black



Blue



Red



Silver



Green



White

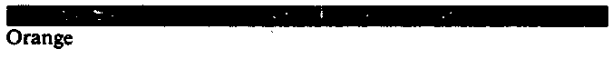

Orange

Rally Striping (Included in RPO Z26)

Distinctive triple-band lower body side and rear striping. Available in five colors (shown) keyed to exterior body and interior color; Orange, Gold, Red, White or Black. See chart on page 15 for availability.

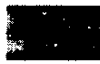
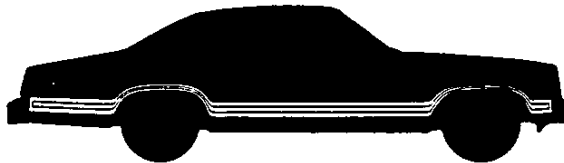

Orange



White



Gold



Black



Red

BODY SIDE MOLDING & PIN STRIPING COLORS WITH VINYL ROOF

EXTERIOR COLOR	CODE		VINYL ROOF COLOR						
			Black BB	Beige UU	Light Blue Metallic DD	Dark Carmine Metallic RR	Light Green GG	Silver QQ	White WW
Beige	61	Molding	Beige	Beige	--	--	--	--	Beige
		Stripe	Gold	Gold	--	--	--	--	White
Black	19	Molding	Silver	Beige	Blue	--	--	Silver	Silver
		Stripe	Gold	Gold	Blue	--	--	Silver	White
Bright Blue Metallic	24	Molding	Silver	--	--	--	--	Silver	Silver
		Stripe	Black	--	--	--	--	Silver	White
Dark Blue Metallic	29	Molding	Silver	--	Blue	--	--	Silver	Silver
		Stripe	Silver	--	Silver	--	--	Silver	White
Light Blue Metallic	22	Molding	Silver	--	Blue	--	--	--	Blue
		Stripe	Black	--	Blue	--	--	--	White
Dark Brown Metallic	69	Molding	--	Beige	--	--	--	--	Beige
		Stripe	--	Gold	--	--	--	--	White
Camel Metallic	63	Molding	Beige	Beige	--	--	--	--	Beige
		Stripe	Gold	Gold	--	--	--	--	White
Carmine Metallic	77	Molding	Carmine	--	--	Carmine	--	Silver	Carmine
		Stripe	Red	--	--	Red	--	Silver	White
Light Green	40	Molding	Green	--	--	--	Green	--	Green
		Stripe	Black	--	--	--	Green	--	Green
Medium Green Metallic	44	Molding	Green	--	--	--	Green	--	Green
		Stripe	Black	--	--	--	Green	--	White
Red	75	Molding	Carmine	--	--	--	--	--	Carmine
		Stripe	Black	--	--	--	--	--	White
Silver	15	Molding	Silver	--	--	--	--	Silver	Silver
		Stripe	Black	--	--	--	--	Black	White
White	11	Molding	Silver	Beige	Blue	--	--	--	Beige
		Stripe	Black	Gold	Blue	--	--	--	Gold
Bright Yellow	51	Molding	Silver	--	--	--	--	--	Silver
		Stripe	Black	--	--	--	--	--	White

BODY SIDE MOLDING & PIN STRIPING COLORS WITHOUT VINYL ROOF

EXTERIOR COLOR	COLOR CODE					MOLDING (RPO BW2)	STRIPE (RPO D85)
	LOWER	UPPER	TWO-TONE				
Beige	61	61	--			Beige	Gold
Black	19	19	--			Silver	Gold
Bright Blue Metallic	24	24	11			Silver	Silver
Dark Blue Metallic	29	29	--			Silver	Silver
Light Blue Metallic	22	22	--			Blue	Blue
Dark Brown Metallic	69	69	61			Beige	Gold
Camel Metallic	63	63	61			Beige	Gold
Carmine Metallic	77	77	11			Carmine	Red
Light Green	40	40	--			Green	Green
Medium Green Metallic	44	44	11			Green	Gold
Red	75	75	11			Carmine	Gold
Silver	15	15	--			Silver	Red
White	11	11	--			Beige	Gold
Bright Yellow	51	51	--			Silver	Orange

NOVA RALLY STRIPING

EXTERIOR COLOR	CODE	INTERIOR COLOR						
		Black	Blue	Camel	Carmine	White/Black	White/Blue	White/Carmine
Beige	61	Orange		Gold		Gold		
Black	19	Red	White	Gold	Red	White		Red
Bright Blue Metallic	24	Black	White			Black	White	
Dark Blue Metallic	29	Gold	White	Gold		White	White	
Light Blue Metallic	22	Black	White			Black	White	
Dark Brown Metallic	69	Orange		Gold		White		
Camel Metallic	63	Orange		Gold		White		
Carmine Metallic	77	Orange		Orange	Red	White		White
Light Green	40	Black		Gold		White		
Medium Green Metallic	44	Black		Gold		White		
Red	75	Orange		Orange	White	White		White
Silver	15	Black	Black		Red	Black		
White	11	Black	Black	Gold	Red	Black	Black	Red
Bright Yellow	51	Black		Black		Black		

See Dealer Order Guide for latest available information.

AVAILABLE OPTIONS

	RPO	Price	Nova Custom	Nova
Air Conditioning. Includes Heavy-Duty Radiator with six-cylinder engine	C60		•	•
Axles:				
Performance Axle Ratio	G92		•	•
Limited Slip Differential	G80		•	•
Battery, Heavy-Duty	UA1		•	•
Belts, Deluxe Color-Keyed Seat & Shoulder. NA with black or black/white interior trim	AK1		•	•
Brakes, Power. Required with V8 engine	J50		•	•
Bumper Rub Strips & Guards—Front & Rear	V30		•	•
Clock, Electric. Included with Special Instrumentation. NA with AM/FM Stereo Radio with Digital Clock Display	U35		•	•
Console. Custom Coupe with Bucket Seats only. NA with Three-Speed Manual Transmission	D55		•	NA
Defogger, Rear Window. (Blower Type)	C50		•	•
Door Lock System, Power	AU3		•	•
Emission Equipment: See Power Teams for availability				
Standard Emission System	NA5		•	•
California Emission Requirements	YF5		•	•
High Altitude Emission Equipment	NA6		•	•
Engines: See Power Teams for availability				
5.0 Litre 2-Bbl. V8	LG3		•	•
5.7 Litre 4-Bbl. V8	LM1		•	•
Floor Mats, Color-Keyed—Front & Rear	B37		•	•
Gage Package. Includes Econominder, voltmeter and temperature gages. NA with Special Instrumentation	UF7		•	•
Glass, Tinted	A01		•	•
Horns, Dual	U05		•	•
Instrumentation, Special. Includes tachometer, voltmeter, temperature gage and clock. NA with Gage Package	U14		•	•
Interior Decor Package. Includes Day/Night Inside Mirror, cigarette lighter, glove compartment light, right front door courtesy light switch and bright instrument cluster accents	ZJ3		S	•
Lighting, Auxiliary. Includes ashtray, instrument panel courtesy, luggage compartment, underhood lights and headlight reminder buzzer; plus glove box light and right front door courtesy light switch on Nova models. Also includes rear compartment light on Nova Hatchback Coupe	TR9		•	•
Mirrors:				
Day/Night Inside Rearview. Included with Interior Decor Package on Nova models	D31		S	•
Remote Control Outside Rearview—LH	D33		•	•
Sport, LH Remote & RH Manual	D35		•	•
Moldings:				
Deluxe Body Side. Includes color-keyed vinyl insert. NA with Nova Rally Equipment	BW2		•	•
Body Side. Includes black vinyl insert. NA with Nova Rally Equipment	B84		•	•
Door Edge Guard	B93		•	•
Roof Drip. Included with Value Appearance Group and Vinyl Roof Cover	B80		•	•
Bright Rocker	B51		•	•
Wheel Opening. NA with Nova Rally equipment; included with Value Appearance Group	B96		•	•
Wheel Opening, Wide. NA with Nova Rally, Body Side Pin Striping or RPO B96 Body Side Moldings	B74		•	•
Side Window Reveal	B90		•	•
Nova Rally Equipment. NA on 4-Door Sedan models or with Two-Tone Paint. Includes color-keyed triple-band lower body side and rear panel striping. Color-Keyed Rally Wheels with bright trim rings, lug nuts and centercaps plus "Nova Rally" nameplate on grille and front fenders	Z26		•	•

	RPO	Price	Nova Custom	Nova
Paint, Two-Tone. (See Color and Trim Selections)	--	--	•	•
Radiator, Heavy-Duty. Included with Air Conditioning on six-cylinder models	V01		•	•
Radio Equipment: (Note: Check Dealer Order Guide for other equipment included or required)				
Delco AM Radio	U63		•	•
Delco AM/FM Radio	U69		•	•
Delco AM/FM Stereo Radio	U58		•	•
Delco AM Radio with 8-Track Stereo Tape	UM1		•	•
Delco AM/FM Stereo Radio with 8-Track Stereo Tape	UM2		•	•
Delco AM/FM Stereo Radio with Stereo Cassette Tape	UN3		•	•
Delco AM/FM Stereo Radio with Digital Clock Display. NA with Special Instrumentation	UY8		•	•
Speaker, Rear Seat. Available only with AM or AM/FM Radios	U80		•	•
Windshield Antenna. Included with factory-installed radios	U76		•	•
Roof Covers: (See Color and Trim Selections)				
Cabriolet. NA on Hatchback Coupe, 4-Door Sedans or with Swing-Out Rear Side Windows	AB8		•	•
Vinyl Roof Cover	--		•	•
Seats, Bucket. Available on Nova Custom Coupe only. (See Color and Trim Selections)	--		•	NA
Speed Control, Automatic. Available with Automatic Transmission and Power Brakes only	K30		•	•
Steering, Power	N41		•	•
Steering Wheel, Comfortilt. NA with Three-Speed Manual Transmission	N33		•	•
Stowaway Spare Tire. Standard on Hatchback Coupe	N65		•	•
Striping, Body Side Pin. NA with Wide Wheel Opening Moldings or Nova Rally Equipment	D85		•	•
Suspension Equipment:				
Heavy-Duty Front & Rear Suspension. Includes larger diameter front stabilizer, higher-rate front and rear springs and shock absorbers	F40		•	•
Sport Suspension. Includes larger diameter front stabilizer, added rear stabilizer, special front and rear springs and shock absorbers plus 14" x 7" wheels. Available only with V8 engine and steel belted radial ply tires. NA with Heavy-Duty Front & Rear Suspension	F41		•	•
Tires:				
E78-14 Bias Belted White Stripe	QEH		•	•
FR78-14 Steel Belted Radial Ply Blackwall	QDV		•	•
FR78-14 Steel Belted Radial Ply White Stripe	QDW		•	•
FR78-14 Steel Belted Radial Ply White Lettered	QBT		•	•
Transmissions: See Power Teams for availability				
Four-Speed Manual. Available with 5.0 Litre V8 only	MM4		•	•
Automatic	MX1		•	•
Trim, Interior: (See Color and Trim Selections)				
Custom Sport Cloth Interior	--		•	NA
Sport Cloth Interior. NA with Nova Hatchback	--		NA	•
Value Appearance Group. Includes bright Roof Drip, Side Window Reveal, Wheel Opening and Rocker Panel Moldings. NA with Nova Rally Equipment	ZJ5		•	•
Wheel Trim:				
Full Wheel Covers	P01		•	•
Color-Keyed Rally Wheels. Includes bright trim rings and centercaps. Included with Rally Sport Equipment	ZJ7		•	•
Wire Wheel Covers. Available with steel belted radial ply tires only	N95		•	•
Windows:				
Power	A31		•	•
Swing-Out Rear Side. Coupes only	A20		•	•
Windshield Wiper System. Intermittent	CD4		•	•

NA—Not Available S—Standard •—Available at extra cost

See Options Section for Additional Details and Illustrations.

Nova/17

POWER TEAMS

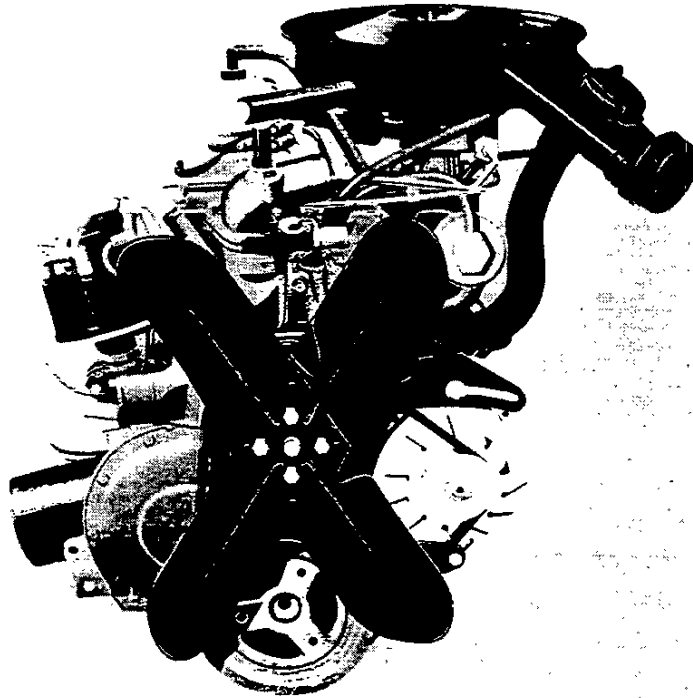

Standard 4.1 Litre 1-Bbl. L6 Engine

Engine	RPO No.	Power Rating*	Displacement (cubic inches)	Engine Availability	Transmission Availability		
					Three-Speed Manual RPO MM3	Four-Speed Manual (1) RPO MM4	Automatic RPO MX1

ALL STATES EXCEPT CALIFORNIA
(with Standard Emission System—RPO NA5)

4.1 Litre 1-Bbl. L6 (A)	L22	115	250	Std.	Std.	NA	EC
5.0 Litre 2-Bbl. V8 (B)	LG3	130	305	EC (2)	NA	EC	EC

ALL STATES EXCEPT CALIFORNIA
(with High Altitude Emission Equipment—RPO NA6)

5.7 Litre 4-Bbl. V8 (B)	LM1	165	350	EC (2)	NA	NA	EC
-------------------------	-----	-----	-----	--------	----	----	----

CALIFORNIA ONLY
(with California Emission Requirements—RPO YF5)

4.1 Litre 1-Bbl. L6 (A)	L22	90	250	Std.	NA	NA	EC
5.0 Litre 2-Bbl. V8 (B)	LG3	125	305	EC (2)	NA	NA	EC
5.7 Litre 4-Bbl. V8 (B)	LM1	165	350	EC (2)	NA	NA	EC

*S.A.E. net horsepower as installed. Std.—Standard. NA—Not Available. EC—Available at extra cost.
(1) With floor-mounted shift control (2) Power Brakes (RPO J50) required.

(A) Produced by GM—Chevrolet Motor Division at the Flint, Michigan Engine Plant.
(B) Produced by GM—Chevrolet Motor Division at the Flint, Michigan; Tonawanda, New York and GM of Canada Engine Plants.

See EPA section for mileage estimates.

BODY/CHASSIS FEATURES

Standard on 1979 Nova

Body Structure & Features

- All-welded heavy-gage steel body construction with cowl, roof, underbody and body panels precision welded to form rigid body shell
- Heavy-gage steel roof panel with supplementary inner panel
- Heavily ribbed and formed underbody with transverse stiffeners welded to underbody and body sills
- Flush and dry sill panels
- Double panel roof, door, hood and deck lid
- Flush-mounted windshield and rear window mounted to body
- Counterbalanced hood, deck lid for ease of operation
- Front and rear inner fenders for corrosion protection
- Flow-thru ventilation system for passenger comfort
- Bolt-on front-end sheet metal cushion-mounted to stub frame and radiator support assembly for

ease of service

- Dual-speed electric windshield wipers
- Durable acrylic finish

Chassis Features

- Front disc/rear drum brake system
- Disc brake audible wear sensors to let you know when linings need replacing
- Vented front disc brake rotors and finned rear brake drums aid heat dissipation
- Delcotron generator with built-in solid-state regulator
- High Energy Ignition system
- Coolant recovery system
- Long recommended service intervals for oil change, oil filter, spark plugs, chassis lubrication and available automatic transmission fluid
- Visible ball joint wear indicators on front suspension lower

control arms for quick and easy wear inspection

- Delco Freedom battery never needs refilling. Sealed side terminals help prevent corrosion buildup
- Separate front stub frame unit cushioned-mounted to body
- Steel bumpers with high-strength steel reinforcements
- Computer-selected front coil springs and multi-leaf rear springs
- Front ride stabilizer to help control sway
- Forward-mounted recirculating ball steering gear and linkage
- Independent front coil suspension
- Early Fuel Evaporation systems on all engines to hasten engine warm-up
- Tire tread wear indicators
- Bias-mounted rear shock absorbers
- GM Specification E78-14 bias belted blackwall tires and 14" x 6" wheels

SOUND DEADENING TREATMENT

- 1. Poly-skinned Tuflex[®] cowl insulation (Nova Custom only)
- 2. Asphalt saturated felt
- 3. Mastic and Amberlite[®] on back of front seat (Nova Custom only)
- 4. Mastic sealing strip on roof side panel
- 5. Mastic and Amberlite[®] under package shelf (Nova Custom only)
- 6. Mastic on upper quarter filler panel
- 7. Amberlite[®] on forward portion of trunk floor
- 8. Spray-on sound deadener on inner wheelhouse panel
- 9. Sound deadener applied to inner quarter panel (Nova Custom only)

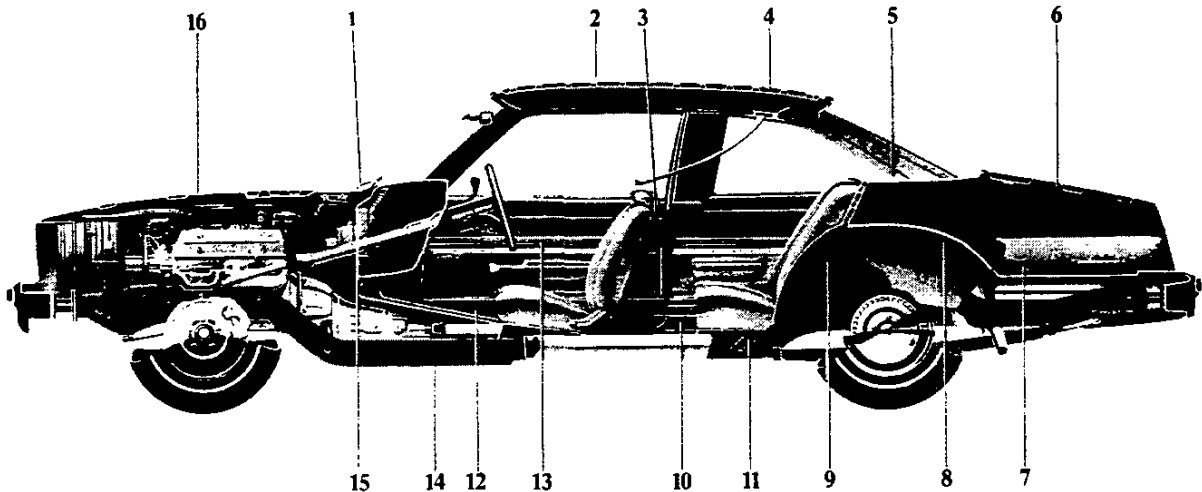

- 10. Amberlite[®] insulator on rear passenger compartment floor
- 11. Mastic and fiber sound deadener on rear floor panel (Nova Custom only)
- 12. Mastic and Amberlite[®] on front passenger compartment floor
- 13. Spray-on sound deadener on inside door panels
- 14. Mastic and fiber sound deadener on front floor panel (Nova Custom only). Amberlite[®] insulator on Nova and Nova Custom
- 15. Mastic and fiber sound deadener on lower portion of body side shroud panel (Nova Custom only)
- 16. Fiberglass hood blanket insulator (Nova Custom only)

ANTI-CORROSION MEASURES

- 1. Flexible precision molded polymer front bumper outer filler panels
- 2. Precision molded polymer headlamp bezels

- 3. Precision molded polymer grille
- 4. Inner fenders to restrict road splash
- 5. Body and sheet metal chemi-

- cally sprayed for corrosion resistance
- 6. Body and sheet metal sprayed with four corrosion-resistant primers

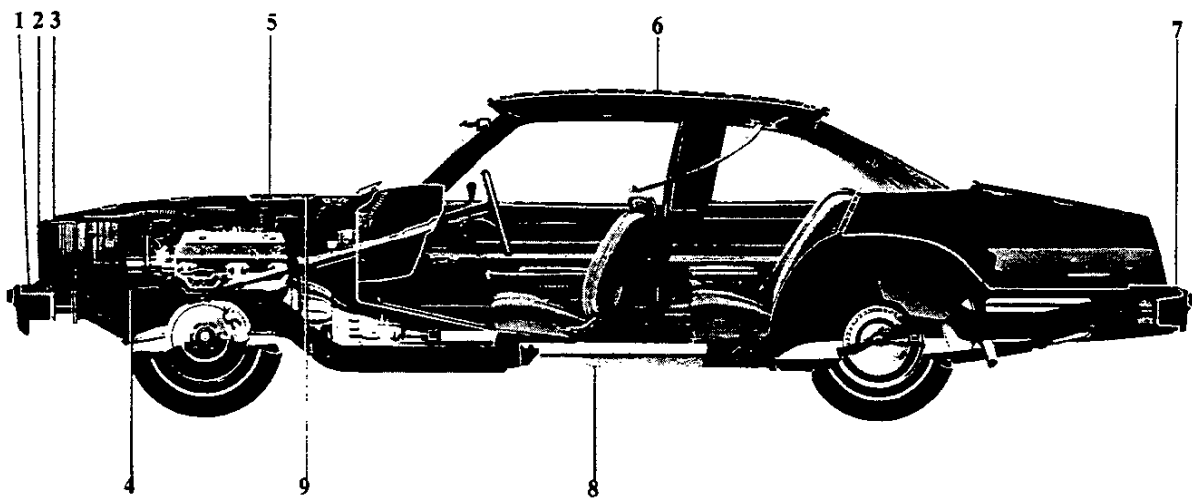

- 7. Flexible precision molded polymer plastic rear bumper filler panels
- 8. Lower body areas vulnerable

- to corrosion sprayed with rust-inhibiting compound
- 9. Fenders and hood dipped or flow-coated with primer to

insure coating inside seams and secluded areas

EQUIPMENT SUMMARY

	Nova Custom Coupe and Sedan	Nova Coupe, Sedan and Hatchback
EXTERIOR		
Bright windshield reveal molding	S	S
Single rectangular headlights	S	S
Bright headlight bezels	S	S
Chrome plated grille	S	S
Bright lower hood molding and fender extensions	S	S
Bright outside rearview mirror	S	S
Marker lamps with bright bezels front and rear	S	S
Bright hubcaps	S	S
Bright rear window reveal molding	S	S
Dual unit taillights with bright trim	S	S
INTERIOR		
Conventional full-width front seat	S	S
Custom interior seat and sidewall trim	S	NA
Simulated wood-grain strip on door trim panels	S	NA
Simulated wood-grain accents on instrument cluster	S	NA
Color-keyed instrument panel pad	S	S
Black, soft vinyl steering wheel	S	S
Speedometer calibrated in mph and kph (kilometers per hour)	S	S
Glove compartment door and lock	S	S
Glove compartment light	S	EC
Center dome light with bright bezel	S	S
Passenger door dome light switch	S	EC
Cigarette lighter	S	EC
Day/night inside rearview mirror	S	EC
Cloth covered headlining	S	NA
Perforated hardboard formed headlining	NA	S
Front door padded armrest with integral door pull handle	S	S
Cloth covered sunvisors	S	NA
Vinyl covered sunvisors	NA	S
Rear bench seat with custom vinyl trim	S	NA
Rear bench seat with standard vinyl trim	NA	S
Folding rear seat with standard vinyl trim (Hatchback only)	—	S
Rear compartment ashtrays	S	NA
Color-keyed cut-pile carpeting	S	S
Luggage compartment mat	S	S
Color-keyed load floor carpet (Hatchback only)	—	S
POWER TEAMS/CHASSIS/MECHANICAL		
4.1 Litre I-Bbl. L6 (250 cu.) engine	S	S
Three-speed manual transmission	S	S

S—Standard EC—Extra Cost NA—Not Available

POWER TEAMS/CHASSIS/MECHANICAL	Nova Custom Coupe and Sedan	Nova Coupe, Sedan and Hatchback
Forward-mounted recirculating ball steering gear and linkage	S	S
Front disc/rear drum brake system	S	S
Vented front disc brake rotors and finned rear brake drums	S	S
Disc brake audible wear sensors	S	S
E78-14 bias belted blackwall tires	S	S
14" x 6" wheels	S	S
Tire tread wear indicators	S	S
Steel bumpers with high-strength steel reinforcements	S	S
Windshield and rear window flush mounted to body	S	S
Flush and dry sill panels	S	S
Front and rear inner fenders	S	S
Coolant recovery system	S	S
Dual-speed electric windshield wipers	S	S
Flow-thru ventilation system	S	S
High Energy Ignition system	S	S
Delco Freedom battery with sealed side terminals	S	S
Delcotron generator with built-in solid-state regulator	S	S
Front stabilizer bar	EC	EC
Front coil springs and multi-leaf rear springs	S	S
Independent front coil suspension	S	S
Visible ball joint wear indicators on front suspension lower control arms	S	S
Double-acting sealed-unit hydraulic front shock absorbers	S	S
Bias-mounted double-acting sealed-unit hydraulic rear shock absorbers	S	S
All-welded heavy-gage steel body construction with cowl, roof, underbody and body panels	S	S
Double panel roof, door, hood, and deck lid	S	S
Counterbalanced hood and deck lid	S	S
Heavily ribbed and formed underbody with transverse stiffeners welded to underbody and body sills	S	S
Separate front frame unit cushion-mounted to body	S	S
Bolt-on front-end sheet metal cushion-mounted to frame and radiator assembly	S	S
Long recommended service intervals for oil change, oil filter, spark plugs, chassis lubrication, and available automatic transmission fluid	S	S

S—Standard EC—Extra Cost NA—Not Available

DIMENSIONS/ SPECIFICATIONS

	Hatchback Coupe	Coupe	4-Door Sedan
EXTERIOR DIMENSIONS			
Wheelbase	111.0	111.0	111.0
Length (overall)	196.7	196.7	196.7
Width (overall)	72.2	72.2	72.2
Height (loaded)	52.7	52.7	53.6
Front tread	61.3	61.3	61.3
Rear tread	59.0	59.0	59.0
Minimum ground clearance	4.8	4.8	4.8
INTERIOR ROOMINESS			
Head room—front	38.2	38.2	39.1
Head room—rear	36.7	36.7	37.1
Leg room—front	41.7	41.7	41.7
Leg room—rear	32.4	32.4	35.2
Hip room—front	53.3	53.3	53.3
Hip room—rear	52.8	52.8	53.6
Shoulder room—front	56.6	56.6	56.6
Shoulder room—rear	55.3	55.3	56.7
LUGGAGE COMPARTMENT			
Liftover height	27.4	27.4	27.4
Interior length (max.)	49.7‡/76.6†	—	—
Usable luggage space (cu. ft.)	29.2†	13.4	13.0
RATED FUEL TANK CAPACITY (gallons)			
	21	21	21
CURB WEIGHT (pounds)			
Nova Custom	—	3306	3340
Nova	3379	3255	3293

†With rear seat folded

‡With rear seat up

METRIC (U.S. Customary)

1979



Specifications Form Passenger Car

Manufacturer Chevrolet Motor Division General Motors Corporation	Car Line Nova	
Mailing Address Chevrolet Engineering Center 30003 Van Dyke Warren, Michigan 48090	Model Year 1979	Issued: September, 1978 Revised (*)

The information contained herein is prepared, distributed by, and is solely the responsibility of the automobile manufacturing company to whose products it relates. Questions concerning these specifications should be directed to the manufacturer whose address is shown above. This specification form was developed by automobile manufacturing companies under the auspices of the Motor Vehicle Manufacturers Association of the United States, Inc.

The General Specifications herein are those in effect at date of compilation and are subject to change without notice by the manufacturer.

MVMA Specifications Form

Passenger Car

Table of Contents

1	Car Models
2	Power Teams
3-7	Engine
7	Exhaust System
8	Fuel System
9	Cooling System
10, 11	Vehicle Emmission Control
12-14	Electrical
15-17	Drive Units
18	Tires and Wheels
18, 19	Brakes
20	Steering
21	Suspension—Front and Rear
22	Body—Miscellaneous Information
22	Frame
23	Convenience Equipment
24	Vehicle Mass (Weights)
25	Optional Equipment Mass (Weights)
26-30	Car and Body Dimensions—including Fiducial Marks, Glass, Lamps and Headlamp Shape
31-35	Car and Body Dimension Key Sheets
36	Index

NOTE:

1. This form uses both SI metric units and U.S. Customary units. The Metric unit of measurement is presented first, and the U.S. Customary unit follows in parentheses.
2. UNLESS OTHERWISE INDICATED:
 - a. Specifications apply to standard models without optional equipment. Significant deviations are noted.
 - b. *Nominal design dimensions are used throughout these specifications.*
 - c. All linear dimensions are in millimetres (inches), and all mass (weight) specifications are in kilograms (pounds).
3. The General Specifications herein are those in effect at date of completion and are subject to change without notice by the manufacturer.
4. A printed or computer tape supplement containing additional Car and Body Dimensions and/or drawings (based in part on SAE J1100a "Motor Vehicle Dimensions") may be available from the manufacturer.

MVMA Specifications Form
Passenger Car

Car Line Nova
 Model Year 1979 Issued 9/78 Revised (*) _____

Car Models

Model Description (Include Line Drawings of Vehicles, if Desired)	Make, Car line, Series, Body Type (Mfg's Model Code)	No. of Designated Seating Positions (Front/Rear)	Max. Trunk/Cargo Load— Kilograms (Pounds)
	MODEL NUMBERS	FRONT	REAR
NOVA			
2-Door Hatchback Coupe	1XX17	3	3
2-Door Coupe	1XX27	3	3
4-Door Sedan	1XX69	3	3
NOVA CUSTOM			
2-Door Coupe	1XY27	3	3
4-Door Sedan	1XY69	3	3

NOTE: Any Specifications on the following pages that are specific to California Requirements are indicated accordingly.

MVMA Specifications Form
Passenger Car

Car Line Nova
Model Year 1979 Issued 9/78 Revised (*) _____

U.S. Customary Units Only

Power Teams (Indicate whether standard or optional)

SAE Net bhp (brake horsepower) and net torque corrected to 85° F and 29.38 in. Hg atmospheric pressure.

SERIES# AVAILABILITY	ENGINE						TRANSMISSION	AXLE RATIO (:1) (Std. first) (Indicate A/C ratio)											
	Displ. litres (in ³)	Carb.	Compr. Ratio	SAE Net at RPM		Exhaust System*		A	B	C									
				kW (bhp)	Torque N·m (lb. ft.)														
Base-All States All models	L-6 4.1L (250) RPO L22	1-Bb1	8.0:1 (8.2:1 Calif)	115 @ 3800	200 @ 1600	S	3-Spd. Manual (3.50 low)-Base 3-Spd Automatic 'Auto 350'-Opt	2.56 2.56 2.73(d)	- -	- -									
Optional - All States All models	V-8 5.0L (305) RPO LG3	2-Bb1	8.4:1	130 @ 3200	245 @ 2000	S	4-Spd. Manual (2.85 low)-Base 3-Spd. Automatic 'Auto 350'-Opt	3.08 2.41	- 3.08	-									
Opt.-Calif & Above 4000 Ft Altitude All Models	V-8 5.7L (350) RPO LM1	2-Bb1	8.2:1	165 @ 3800	260 @ 2400	S	3-Spd. Automatic 'Auto 350'-Opt.	2.41	-	3.08									
(#) 'Base' and 'Optional' refer to engine availability. (A) Base - all states. (B) Optional except California. (C) Above 4000 Feet altitude (RPO NA6). (d) California only. Limited slip differential and air conditioning available with all axle ratios. California & Altitudes Above 4000 Feet: <table border="0" style="width: 100%;"> <tr> <td style="text-align: left;"><u>Engine</u></td> <td style="text-align: center;"><u>Horsepower</u></td> <td style="text-align: center;"><u>Torque</u></td> </tr> <tr> <td>4.1 Litre</td> <td style="text-align: center;">90 @ 3600</td> <td style="text-align: center;">175 @ 1600</td> </tr> <tr> <td>5.0 Litre</td> <td style="text-align: center;">125 @ 3200</td> <td style="text-align: center;">235 @ 2000</td> </tr> </table>											<u>Engine</u>	<u>Horsepower</u>	<u>Torque</u>	4.1 Litre	90 @ 3600	175 @ 1600	5.0 Litre	125 @ 3200	235 @ 2000
<u>Engine</u>	<u>Horsepower</u>	<u>Torque</u>																	
4.1 Litre	90 @ 3600	175 @ 1600																	
5.0 Litre	125 @ 3200	235 @ 2000																	

*S—Single D—Dual

MVMA Specifications Form Passenger Car

Car Line Nova
 Model Year 1979 Issued 9/78 Revised (*) _____

U.S. Customary Units only

Engine Description/Carb.

4.1L L-6/1-Bb1 RPO L22	5.0L V-8/2-Bb1 RPO LG3	5.7L V-8/4-Bb1 RPO LM1
---------------------------	---------------------------	---------------------------

Engine — General

Total dressed engine mass (wt) dry*	467.2	537.5	512.8
Type (inline, V, Flat)	In line	90° V	
No. of cylinders	6	8	
Bore	3.876	3.736	4.00
Stroke	3.53	3.48	
Piston Displacement cm ³ (in ³)	250	305	350
Bore Spacing (C/L to C/L)		4.40	
Cyl. No. system (front to rear)	L Bank 1-2-3-4-5-6 R Bank ---	1-3-5-7 2-4-6-8	
Firing Order	1-5-3-6-2-4	1-8-4-3-6-5-7-2	
Cylinder Head Material		Cast iron	
Cylinder Block Material		Cast iron	
Cylinder block deck height	9.15	9.03	
Number of mtg. points	Front Rear	Two One	
Engine installation angle		3°16'	
Recommended fuel Leaded, unleaded		Unleaded	
Fuel antiknock index (R + M) / 2		87	
Cylinder Head Volume — cm ³	70.0	60.5	75.5
Head Gasket Thickness (Compressed)	.038	.021	.021
Head Gasket Volume — cm ³	.503	.243	.28
Deck clearance (minimum) (above or below block)		.025 below	
Minimum Combustion Chamber Volume — cm ³	68.0	59.5	74.8

Engine — Pistons

Material	Aluminum alloy	Cast auto thermic			
Description and finish	Sump head, closed skirt				
Mass, g (weight, oz.)—Piston Only	20.2	17.9	21.3		
Clearance (limits)	Top land	.0245-.0335	.0245-.0335	.0235-.0325	
	Skirt	Top	.0005-.0015 (a)	.0017-.0042 (b)	.0007-.0017 (b)
		Bottom			
Ring groove diameter	No. 1 ring	3.434-3.444	3.320-3.335	3.541-3.556	
	No. 2 ring	3.434-3.444	3.320-3.335	3.541-3.556	
	No. 3 ring	3.446-3.456	3.300-3.315	3.577-3.592	

*Dressed engine mass (weight) includes the following: Material required to make the engine an independent working power unit less radiator hoses, coolant, accelerator controls or engine mountings.
 (a) Measured 1.66 in. from top of piston.
 (b) Measured 1.56 in. from top of piston.

MVMA Specifications Form Passenger Car

Car Line Nova
 Model Year 1979 Issued 9/78 Revised (*) _____

U.S. Customary Units only

Engine Description/Carb.	4.1L L-6/1-Bb1 RPO L22	5.0L V8/2-Bb1 RPO LG3	5.7L V8/4-Bb1 RPO LMT
--------------------------	---------------------------	--------------------------	--------------------------

Engine — Piston Rings

Function (top to bottom)	No. 1. oil or comp.	Compression		
	No. 2. oil or comp.	Compression		
	No. 3. oil or comp.	Oil		
Compression	Description— Material, coating, etc.	Upper Cast alloy iron; L-6-barrel face, V-8-Radius face (a)	Lower Cast alloy iron, tapered face, lubrited (b)	
	Width	(c)	(d)	(e)
	Gap	.010-.020	Upper-.010-.020; Lower - .013-.025	
Oil	Description— material, coating, etc.	L-6 - .006 minimum chrome on two segments, stainless steel spacer expands V-8 - TRW T-flex design, .002" minimum chrome		
	Width	.1850-.1870	.1859-.1879	.1850-.1870
	Gap	.015-.055	.010-.035	.015-.055
Expanders	In oil ring assembly			

Engine — Piston Pins

Material	Chromium steel		
Length	2.990-3.010		
Diameter	.9270-.9273		
Type	Locked in rod, in piston, floating, etc.	Locked in Rod	
	Bushing	In rod or piston	---
	Material	---	
Clearance	In piston	.00015-.00025	.00025-.00035
	In rod		
Direction & amount offset in piston	Major thrust side, 0.060		

Engine — Connecting Rods

Material	Forged steel	1037 or 1038 steel	
Mass, g (weight, oz.)	14.2	13.7	
Length (center to center)	5.695-5.705		
Bearing	Material & Type	Premium Aluminum	
	Overall length	.807	.797
	Clearance (limits)	.0007-.0027	.0013-.0035
	End Play	.007-.016	.006-.016

- (a) L-6 -.004" moly channel, graphite impregnated or brushed.
 V-8 -.0004" chrome flash
 (b) L-6 -Reverse inside bevel
 V-8 -Reverse twist
 (c) L-6 -Upper-.0775-.0780; lower -.0770-.0780.
 (d) 305 V-8 - Upper-.0770-.0780; lower-.0775-.0780
 (e) 350 V-8 - Upper -.0775-.0780; lower-.0770-.0775

MVMA Specifications Form

Passenger Car

Car Line Nova
 Model Year 1979 Issued 9/78 Revised (*) _____

U.S. Customary Units only

Engine Description/Carb.

4.1L L-6/1-Bb1 RPO L22	5.0L V-8/2-Bb1 RPO LG3	5.7L V-8/4-Bb1 RPO LMI
---------------------------	---------------------------	---------------------------

Engine — Crankshaft

Material	Nodular cast iron			
Vibration damper type	Rubber mounted inertia			
End thrust taken by bearing (No.)	7	5		
Crankshaft end play	.002-.006	.002-.007		
Main bearing	Material & type	(a)	(b) (e)	
	Clearance	.0003-.0029	(c)	
	Journal dia. and bearing overall length	No. 1	2.2999x.752	2.4489x.802
		No. 2	2.2999x.752	2.4489x.802
		No. 3	2.2999x.752	2.4489x.802
		No. 4	2.2999x.752	2.4489x.802
		No. 5	2.2999x.752	2.4484x1.533
		No. 6	2.2999x.752	---
No. 7		2.2999x.760	---	
Dir. & amt. cyl. offset	None			
No. bolts/main brg. cap	Two			
Crankpin journal diameter	1.999-2.000	2.099-2.100		

Engine — Camshaft

Location	(d)	In block above crankshaft	
Material	Cast alloy iron		
Bearings	Material	Steel backed babbitt	
	Number	4	5
Type of Drive	Gear, chain or belt	Gear	Silent chain
	Crankshaft gear or sprocket material	Cast iron	Sintered iron
	Camshaft gear or sprocket material	Aluminum	Aluminum-nylon
	Timing chain	No. of links	--
Chain or Belt		Width	--
	Pitch	--	.500

- (a) #1 thru #6 - Premium Aluminum.
#7-Copper lead alloy, except lower with auto. trans-Premium aluminum.
- (b) #1-G66 Conecc; #2 thru 4-premium aluminum. #5 upper-copper lead alloy; #5 lower with man. trans.-copper.
- (c) #1-.0008-.0020; #2,3,4 -.0011-.0023; #5 -.0017-.0033.
- (d) - Above and to right of crankshaft.
- (e) - 350 V-8 - #1 - premium aluminum.

MVMA Specifications Form
Passenger Car

Car Line Nova
Model Year 1979 Issued 9/78 Revised (*) _____

U.S. Customary Units only

Engine Description/Carb.

4.7L L-6/1-Bb1 RPO L22	5.0L V-8/2-Bb1 RPO LG3	5.7L V-8/4-Bb1 RPO LM1
---------------------------	---------------------------	---------------------------

Engine — Valve System

Hydraulic lifters (Std., opt., NA)		Standard				
Valve rotator, type (intake, exhaust)		None	Exhaust			
Push rods (dia., length, material)		.3125x9.612(a)	.3125x7.724 - 1010 steel, carbonitrided			
Rocker ratio		1:75:1	1.50:1			
Operating tappet clearance (indicate hot or cold)	Intake	Zero				
	Exhaust	Zero				
Timing (based on top of ramp points)	Intake	Opens (°BTC)	16	28	28	
		Closes (°ABC)	48	64	72	
		Duration (deg.)	244	272	280	
	Exhaust	Opens (°BBC)	64	78	78	
		Closes (°ATC)	50	30	30	
		Duration (deg.)	294	288	288	
Valve open overlap (deg.)		66	58	58		
Intake Valve	Material (b)		SAE forged 1541 or 1547	SAE 1541 steel	SAE forged steel 1541 or 154	
	Overall length		4.902-4.922		4.870-4.889	
	Actual overall head dia.		1.715-1.725		1.935-1.945	
	Angle of seat & face (deg.)		46 seat, 45 face			
	Seat insert material		None			
	Stem diameter		.3410-.3417			
	Stem to guide clearance		.0010-.3427			
	Lift (at zero lash)		.3880	.373	.390	
	Outer spring press. & length	Valve closed— N at mm (lb. at in.)	78-86 @ 1.66	76-84 @ 1.70		
		Valve open— N at mm (lb. at in.)	170-180 @ 1.26	176-184 @ 1.25	180-188 @ 1.25	
	Inner spring press. & length	Valve closed— N at mm (lb. at in.)	None	Spring damper		
		Valve open— N at mm (lb. at in.)	None	Spring damper		
	Exhaust Valve	Material		Armco 21-4N SAE 1050	21-2N steel - Aluminized head	
		Overall length		4.913-4.933		4.910-4.930
Actual overall head dia.		1.495-1.505				
Angle of seat & face (deg.)		46 seat, 45 face				
Seat insert material		None				
Stem diameter		.3410-.3417				
Stem to guide clearance		.0010-.0027				
Lift (at zero lash)		.4051	.4100			
Outer spring press. & length		Valve closed— N at mm (lb. at in.)	78-86 @ 1.66	76-84 @ 1.61		
		Valve open— N at mm (lb. at in.)	170-180 @ 1.26	184-196 @ 1.16		
Inner spring press. & length	Valve closed— N at mm (lb. at in.)	None	Spring damper			
	Valve open— N at mm (lb. at in.)	None	Spring damper			

(a) 1010 steel carbonitrided
(b) Chrome flash stem.

MVMA Specifications Form
Passenger Car

Car Line Nova
 Model Year 1979 Issued 9/78 Revised (*) _____

U.S. Customary Units only

Engine Description/Carb.

4.1L L-6/1-Bb1 RPO L22	5.0L V-8/2-Bb1 RPO LG3	5.7L V-8/4-Bb1 RPO LM1
---------------------------	---------------------------	---------------------------

Engine — Lubrication System

Type of lubrication (splash, pressure, nozzle)	Main bearings	Pressure		
	Connecting rods	Pressure		
	Piston pins	Splash		
	Camshaft bearings	Pressure		
	Tappets	Pressure		
	Timing gear or chain	Nozzle	Centrifugally oiled from camshaft bearing	
	Cylinder walls	Splash	Pressure, jet cross sprayed	
Oil pump type	Gear			
Normal oil pressure—kPa (lb.) at engine rpm	40 @ 2000	45 @ 2000		
Type oil intake (floating, stationary)	Stationary			
Oil filter system (full flow, part, other)	Full flow			
Capacity of c/case, less filter—refill—L (qt.)	4.0			
Oil grade recommended (SAE viscosity and temperature range)	(b)			
Engine service reqmt. (SD, SE, etc.)	SE			

Engine — Exhaust System

Type (single, single with cross-over, dual, other)	Single	Single with crossover
Muffler No. & Type (reverse flow, straight thru, separate resonator)	One, reverse flow	
Resonator No. & type	None	
Exhaust Pipe	Branch O.D., wall thickness	--
	Main O.D., wall thickness	2.25 x .078*
	Material	Stainless steel tubing
Intermediate Pipe	O.D. & wall thickness	2.25 x .071
	Material	Aluminized steel tubing
Tail Pipe	O.D. & wall thickness	2.0 x .056
	Material	Aluminized steel tubing(a)

(*) Laminated

(a) Single exhaust with dual tailpipes on 305 and 350 V-8 engine

(b) 20°F and above - 20W-20, 10W-30, 10W-40, 20W-40, 20W-50

0° to 60°F-10W, 5W-30, 10W-40, 10W-30

20°F and below -5W-20, 10W-30

MVMA Specifications Form

Passenger Car

Car Line Nova
 Model Year 1979 Issued 9/78 Revised (*) 2/79

U. S. Customary Units

Engine Description/Carb.

4.1L L-6/1-Bb1 RPO L22	5.0L V-8/2-Bb1 RPO LG3	5.7L V-8/4-Bb1 RPO LM1
---------------------------	---------------------------	---------------------------

Engine — Fuel System (See supplemental page for Details of Fuel Injection, Supercharger, etc. if used)

Induction type: Carburetor, fuel injection, supercharger.		Carburetor		
Fuel Tank	Refill capacity—L (U.S. gals.)	21 (Approximately)		
	Filler location	To rear of hinged license plate		
Fuel Pump	Type (elec. or mech.)	Mechanical		
	Locations	Lower right front of engine		
	Pressure range—kPa (psi)	4.5-6.0	7.5-9.0	
Fuel Filter	Type	Fine mesh plastic strainer gasoline tank and		
	Locations	Paper filter element in carburetor inlet		
Carburetor	Choke type	Automatic		
	Intake manifold heat control (exhaust or water)	Exhaust		
	Air cleaner type	Standard	Single snorkel to outside	Ducted air, closed paper element,
		Optional	ducted air, thermac	thermac, single snorkel, steel
	Idle spd.—rpm (spec. neutral or drive)	Manual	800/N	600/N
		Automatic	675/D (600/D)	500/D (600/D)
Idle A/F mix.			500/D	

Carburetor Supplementary Information

Model Usage	Piston Displ. —L (in. ³)	Transmission	Carburetors		No. Used and Type	Barrel Size
			Make	Model (a)		
All	250	Manual	Rochester	17059013	One, 1-Bb1	1.69
		Automatic		17059014 (17059314)		
	305	Manual		17059135	One, 2-Bb1	1.69
		Automatic		17059134 (17059434)		
	350	Automatic		(17059502)	One, 4-Bb1	1.38 pri, 2.25 sec.
				17059582*		

(a) Data in brackets () specific to California
 * - Above 4000 Feet altitude.

MVMA Specifications Form

Passenger Car

Car Line Nova
 Model Year 1979 Issued 9/78 Revised (*) _____

U. S. Customary Units only

Engine Description/Carb.

4.1L L-6/1-Bb1 RPO L22	5.0L V-8/2-Bb1 RPO LG3	5.7L V8/4-Bb1 RPO LMT
---------------------------	---------------------------	--------------------------

Engine — Cooling System

Coolant recovery system (std., opt., none)		Standard		
Radiator cap relief valve pressure—kPa (psi)		15		
Circulation thermostat	Type (choke, bypass)	Choke		
	Starts to open at °C (°F)	195		
Water pump	Type (centrifugal, other)	Centrifugal		
	GPM 1000 pump rpm			
	Number of pumps	One		
	Drive (V-belt, other)	V-belt		
Bearing type		Permanently lubricated double row ball		
By-pass recirculation type (inter., ext.)		Internal		
Radiator core type (cross-flow, vertical, cellular, tube and fin, other)		Crossflow, tube & center		
Cooling System Capacity	With heater—L (qt.)	13.6	16.0	
	Without heater—L (qt.)			
	Opt. equipment—specify—L (qt.)			
Water jackets full length of cyl. (yes, no)		Yes		
Water all around cylinder (yes, no)		Yes		
Radiator hose	Lower	Number and type (molded, straight)	One, molded	
		Inside diameter	1.75	
	Upper	Number and type (molded, straight)	One, molded	
		Inside diameter	1.50	
	By-pass	Number and type (molded, straight)	None	
		Inside diameter	---	
Radiator	Standard	Width	20.8	26.3
		Height		16.97
		Thickness		1.24
	A/C	Width		26.3
		Height		16.97
		Thickness	1.24	1.96
	Heavy duty	Width		26.3
		Height		16.97
		Thickness	1.24	1.96
Fan (Standard)	Number of blades & spacing	4, staggered	7, staggered	
	Diameter	17.62	18.0	19.0
	Ratio—fan to crankshaft rev.	1.16:1		0.949:1
	Fan cutout type	None		
Fan (optional)	No. of blades and spacing	7, staggered		
	Diameter	18.0	19.0	19.5
	Ratio—fan to crankshaft rev.	1.25:1		0.949:1
	Fan cut-out type	Thermomodulated viscous type(a)		

(a) Not available with 305 CID V8.

MVMA Specifications Form

Passenger Car

Car Line Nova
 Model Year 1979 Issued 9/78 Revised (*) _____

U.S. Customary Units only

Engine Description/Carb.

4.1L L-6; 5.0L & 5.7L V-8 All states except Calif.	4.1L L-6; 5.0L & 5.7L V-8 California & 5.7L V-8 Above 4000 feet altitude
---	--

Vehicle Emission Control

Exhaust Emission Control	Type (Air injection, engine modifications, other)		Engine Modifications	Manifold Air Injection
	Air Injection Pump	Type		Semi-articulated vane
		Displacement -- cm ³ (in ³)		19.3
		Drive ratio		1.15:1 (L-6); 1.33:1 (V-8)
		Drive type		Crankshaft pulley
		Relief valve (type)		Diverter valve
	Air Injection System	Filter (describe)		Centrifugal air cleaner
		Air distribution (head, manifold, etc.)		Exhaust pipe
		Point of entry		Exhaust pipe
		Injection tube i.d.		.2700
		Check valve type		Pressure plate system
	Exhaust Gas Recirculation System	Backfire protection (type)		Diverter valve
		Type (controlled flow, open orifice, other)		Controlled flow
		Valve type		Vacuum modulated shut-off and metering valve
		Valve location		L-6-right front; V-8 right rear of manifold
		Control energy source		Carburetor vacuum
		Exhaust source		Manifold exhaust crossflow
		Exhaust cooler type		None
	Catalytic Converter System	Orifice no. and size		One; 0.030
		Point of exhaust injection (spacer, carburetor, manifold, other)		Inlet Manifold
Catalyst		Type		Platinum - palladium
		Volume -- L (in ³)		260
Other	Substrate type		Alumina	
	Container location		Beneath right front underbody; also, monolith manifold converter of .015 volume in California on 250 L-6.	
	Carburetor Hot Air		Thermostatically controlled air cleaner regulates and mixes heated air from incoming cold air to reduce hydrocarbon emission.	

CONTROLLED
COMBUSTION
SYSTEM

MVMA Specifications Form
Passenger Car

Car Line Nova
 Model Year 1979 Issued 9/78 Revised (*) _____

U.S. Customary Units only

Engine Description/Carb.

4.7L L-6/1-Bb1 RPO L22	5.0L V-8/2-Bb1 RPO LG3	5.7L V-8/4-Bb1 RPO LM1
---------------------------	---------------------------	---------------------------

Vehicle Emission Control (Continued)

Crankcase Emission Control	Type (ventilates to atmos., induction system, other)	Standard	Induction system	
		Optional	---	
	Control Unit	Make and model	A.C. Spark Plug	
		Location	Valve rocker cover - L-6, upper rear; V-8, left front	
		Energy source (manifold vacuum, carburetor, other)	Manifold vacuum	
	Complete System	Control method (variable orifice, fixed orifice, other)	Variable orifice	
		Discharges (to intake manifold, other)	Intake manifold	
		Air inlet (breather cap, other)	Carburetor air cleaner	
		Flame arrestor (screen, other)	screen	
	Evaporative Emission Control	Fuel Tank	Thermal expansion volume—dm ³ (ft ³)	Approximately 10% of refill capacity
Relief Pressure kPa (psi) and location			1.1	
Vacuum relief kPa (psi) and location			0.7	
Vapor-liquid separator type			Integral with fuel tank	
Vapor vented to (crankcase, canister, other)			Canister	
Carbu- retor	Vapor vented to (crankcase, canister, other)		Canister	
Vapor Storage	Storage provision (crankcase, canister, other)		Canister	
	Volume—dm ³ (ft ³) or capacity (grams)	Approximately 50 grams		
	Control valve type	Controlled by orifice and carburetor throttle body and throttle blade position		

MVMA Specifications Form Passenger Car

Car Line Nova
 Model Year 1979 Issued 9/78 Revised (*) _____

U. S. Customary Units only.

Engine Description/Carb.

4.1L L-6/1-Bb1 RPO L22	5.0L V-8/2-Bb1 RPO L63	5.7L V-8/4-Bb1 RPO LM1
---------------------------	---------------------------	---------------------------

Electrical — Supply System

Battery	Make and Model	Delco Remy 'Freedom'		
	Voltage Rtg.—V— & Total Plates	12V-2500 watts	12V-3200 watts	
	SAE Designation No. and/or capacity	60 minute Reserve Capacity	80 minute reserve capacity	
	Location	Engine compartment, right front		
Generator or Alternator	Make	Delco Remy		
	Model	1102491	1102394	
	Type and rating	Diode Rectified-37A		
	Output at engine idle (neutral) A	12-20		
	Ratio—Gen. to Cr/s rev.	2.73:1		
Regulator	Make	Delco Remy		
	Model	---		
	Type	Micro circuit unit; integral with alternator		
	Regulated	Voltage	13.8-14.8	
		Current A		
	Voltage test conditions	Temperature—°C (°F)	Operating	
Load A		3-8		
Other		None		

Electrical — Starting System

Starting Motor	Make	Delco Remy		
	Model	1109061	(a)	1109065
Motor Drive	Engagement Type	Positive shift solenoid		
	Pinion engages from (front, rear)	Rear		
	Pinion	9		
	Number of teeth	Flywheel	Manual	153
Auto			153	168

(a) Manual trans.-1109074; auto, trans. - 1109064.

MVMA Specifications Form

Passenger Car

Car Line Nova
 Model Year 1979 issued 9/78 Revised (*) _____

U.S. Customary Units only.

Engine Description/Carb.

4.1L L-6/1-Bb1 RPO L22	5.0L V-8/2-Bb1 RPO LG3	5.7L V-8/4-Bb1 RPO LM1
---------------------------	---------------------------	---------------------------

Electrical — Ignition System — Distributor

Distributor	Manual	1110748	1103281	---
	Automatic	1110748 (1110716)	1103379 (1103285)	1103353 (1103285)
Timing	Manual	8°BTC	4°BTC	---
	Automatic	10°BTC (6° BTC)	4°BTC (4°BTC)	8°BTC (8°BTC)

Distributor Model	CENTRIFUGAL ADVANCE Crankshaft Degrees at Engine RPM			VACUUM ADVANCE Crankshaft Deg. at kPa (in. of Hg.)	
	Start	Intermediate	Maximum	Start	Maximum
1110748	0 @ 1000	7 @ 1600	20 @ 4200	0 @ 4	20 @ 10
1110716	0 @ 1000	7 @ 1600	20 @ 4200	0 @ 4	15 @ 12
1103285	0 @ 1200	12 @ 2000	22 @ 4200	0 @ 4	10 @ 8
1103353	0 @ 1100	12 @ 1600	22 @ 4600	0 @ 4	20 @ 10
1103281	0 @ 1000	10 @ 1700	20 @ 3800	0 @ 4	18 @ 12
1103379	0 @ 1000	10 @ 1700	20 @ 3800	0 @ 3	20 @

Data in brackets () specific to California

MVMA Specifications Form

Passenger Car

Car Line Nova
 Model Year 1979 Issued 9/78 Revised (*) _____

U. S. Customary Units only

Engine Description/Carb.

4.1L L-6/1-Bb1 RPO L22	5.0L V-8/2-Bb1 RPO LG3	5.7L V-8/4-Bb1 RPO LM1
---------------------------	---------------------------	---------------------------

Electrical — Ignition System

Type	Conventional — Std., Opt., N.A.	---	
	Transistorized — Std., Opt., N.A.	---	
	Other (specify)	High Energy Ignition System (H.E.I.)	
Coil	Make	Delco Remy	
	Model	Intearal with distributor cap	
	Current	Engine stopped—A	
		Engine idling—A	
Spark Plug	Make	A.C. Spark Plug	
	Model	R46TS R45TS	
	Thread (mm)	14	
	Tightening torque—N·m (lb. ft.)	25	
	Gap	.035 .045	

Electrical — Suppression

Locations & type	Non Metallic high tension ignition cables
------------------	---

Electrical — Instruments and Equipment

Speed-ometer	Type	Inline with pointer
	Trip odometer (std., opt., N.A.)	NA
EGR maintenance indicator		NA
Charge Indicator	Type	Tell-tale
	Warning device	NA
Temperature Indicator	Type	Tell-tale
	Warning device	NA
Oil pressure indicator	Type	Tell-tale
	Warning device	NA
Fuel indicator	Type	Electric Gauge
	Warning device	NA
Wind-shield Wiper	Type—standard	Electric two-speed
	Type—optional	Intermittent
	Blade length	15.9"
	Swept area—cm ² (in. ²)	680.5
Wind-shield Washer	Type—standard	Pushbutton
	Type—optional	NA
	Fluid level indicator	NA
Horn	Type	Vibrator
	Number used	One
	Current draw (A) per horn	4.5-6.5 @ 12.5 Volts (Low note)
Other	Restraint system warning light and buzzer. Brake failure warning light and parking brake light.	

MVMA Specifications Form Passenger Car

Car Line Nova
 Model Year 1979 Issued 9/78 Revised (*) _____

U.S. Customary Units only.

Engine Description/Carb.

4.1L L-6/1-Bb1 RPO L22	5.0L V-8/2-Bb1 RPO LG3
---------------------------	---------------------------

Drive Units — Clutch (Manual Transmission)

Make & type	Chevrolet, single dry disc. Centrifugal	Chevrolet, single dry disc. Centrifugal	
Type pressure plate springs	Diaphragm		
Total spring load—N (lb.)	2100-2300	2100-2300	
No. of clutch driven discs	One		
Clutch facing	Material	Woven type asbestos	
	Manufacturer	Chevrolet	
	Part Number	471544	458629
	Rivets/Plate	40	40
	Rivet size	.184 x .208	.184 x .208
	Outside & inside dia.	10.34 x 6.50	10.34 x 6.50
	Total eff. area—cm ² (in. ²)	101.6	101.6
	Thickness	.135	
Engagement cushion-method	Flat spring steel between facings		
Release bearing	Type & method of lubrication	Single row ball, packed and sealed	
Torsional damping	Methods: springs, friction material	Coil springs	

Drive Units — Transmissions

Manual 3-speed (std., opt., N.A.)	Std.	N.A.
Manual 4-speed (std., opt., N.A.)	N.A.	Optional
Manual 5-speed (std., opt., N.A.)	N.A.	
Manual overdrive (std., opt., N.A.)	N.A.	
Automatic (std., opt., N.A.)	Optional	

Drive Units — Manual Transmissions

Number of forward speeds	3	4	
Transmission ratios	In first	3.50	2.85
	In second	1.89	2.02
	In third	1.00	1.35
	In fourth	--	1.00
	In fifth	--	--
In reverse	3.62	2.85	
Synchronous meshing, specify gears	All forward gears		
Shift lever location	Steering column	Floor	
Lubricant	Capacity—L (pt.)	3	
	Type recommended	GL-5 Gear lubricant	
	SAE viscosity number	Summer	80W or 80W-90
		Winter	80W or 80W-90
Extreme cold		80W or 80W-90	

MVMA Specifications Form Passenger Car

Car Line Nova
 Model Year 1979 issued 9/78 Revised (*) _____

U.S. Customary Units only.

Engine Description/Carb.

4.1L L-6/1-Bb1 RPO L22	5.0L V-8/2-Bb1 RPO LG3	5.7L V-8/4-Bb1 RPO LMI
---------------------------	---------------------------	---------------------------

Drive Units—Automatic Transmission

Trade name	3-Speed Automatic		
Type (describe)	Torque converter with planetary gears		
Selector location	Steering column-standard; floor mounted- Required with floor console		
Gear Ratios	P	Park	
	R	1.93	
	N	Neutral	
	D	2.52-1.52 - 1.00	
	L2	2.52-1.52	
	L1	2.52	
Max. upshift speed—drive range— (mph)	65-80	73-90	73-90
Max. kickdown speed—drive range— (mph)	62-77	70-86	69-86
Torque Converter	Number of elements	3	
	Max. ratio at stall	2.0	
	Type of cooling (air, liquid)	liquid	
	Nominal diameter	11.75	
Lubricant	Capacity—refill—L (pt.)	8	
	Type recommended	Dexron II	
Special transmission features			

Drive Units—Axle

Type (front, rear)	Rear			
Description	Semi floating axle shaft Overhung pinion and ring gear			
Limited Slip differential, type	Disc clutches			
Drive Pinion Offset	1.50 Vertical (7.50" R.G.); 1.75 Vertical (8.50" R.G.)			
No. of differential pinions	Two			
Pinion adjustment (shim, other)	Shim			
Pinion bearing adj. (shim, other)	Collapsible sleeve			
Wheel bearing type	Direct or single row cylindrical roller			
Lubricant	Capacity—L (pt.)	3.25 (7.50" R.G.); 4.0 (8.50" R.G.)		
	Type recommended	GL-5 Gear lubricant		
	SAE viscosity number	Summer	80W or 80W-90	
		Winter	80W or 80W-90	
		Extreme cold	80W or 80W-90	

Axle Ratio Tooth Combinations (See "Power Teams" for axle ratio usage.)

Axle Ratio	2.56	2.73	2.41	2.56	2.73	3.08
No. of teeth	Pinion	16	15	17	16	15
	Ring gear	41	41	41	41	41
Ring Gear O. D.	7.50 (a)			8.50		

(a) Manufacturing option with 250 L-6 engine.

MVMA Specifications Form

Passenger Car

Car Line Nova
 Model Year 1979 Issued 9/78 Revised (*) _____

U.S. Customary Units only.

Engine Description/Carb.

4.1L L-6/1-Bb1 RPO L22	5.0L V-8/2-Bb1 RPO LG3	5.7L V-8/4-Bb1 RPO LM1
---------------------------	---------------------------	---------------------------

Drive Units—Propeller Shaft

Number used		One	
Type (straight tube, tube-in-tube, internal-external damper, etc.)		Straight tube	
Outer diam. x length* x wall thickness	Manual 3-speed trans.	2.75x51.78x.065 (a)	N.A.
	Manual 4-speed trans.	N.A.	2.75x51.78x.065 N.A.
	Manual 5-speed trans.	Not Available	
	Overdrive	Not Available	
	Automatic transmission	2.75x51.78x.065 (a)	2.75x51.78x.065
Inter-mediate bearing	Type (plain, anti-friction)	None	
	Lubrication (fitting, prepack)	---	
Slip Yoke	Type	Yoke	
	Number of teeth	27	
	Spline O. D.	1.502-1.503	
Universal joints	Make and Mfg. No.	Chevrolet-1285	Manual Trans.-1285 Auto. Trans.-1315
	Number used	Two	
	Type (ball and trunnion, cross)	Cross	
	Rear attach (u-bolt, clamp, etc.)	Strap & bolt	
	Bearing	Type (plain, anti-friction)	Anti-friction
Lubric. (fitting, prepack)		Pre-pack	
Drive taken through (torque tube or arms, springs)		Leaf springs	
Torque taken through (torque tube or arms, springs)		Leaf springs	

*Center to center of universal joints, or to centerline of rear attachment.

(a) Length with 8.50 inch ring gear - 53.14" with 7.50 inch ring gear.

MVMA Specifications Form Passenger Car

Car Line Nova
 Model Year 1979 Issued 9/78 Revised (*) 2/79

U.S. Customary Units only.

Engine Description/Carb.

Base	Rally
------	-------

Drive Units—Tires And Wheels (Standard)

TIRES	Size, load range, ply		E78-14 (B/W-Std;W/S-Opt)	
	Type (bias, radial, etc.)		Bias belted	
	inflation pressure (cold) for recommended max. vehicle load	Front—kPa (psi)	32	
		Rear—kPa (psi)	32	
	Rev./mile—at 70 km/h (45 mph)		796	
WHEELS	Type & material		Short spoke disc, steel	
	Rim (size & flange type)		14x6 (Regular)	14x6 (Rally)
	Wheel offset		0.50	
	Attachment	Type (bolt or stud)	Stud	
		Circle diameter	4.75	
		Number & size	5 hex nuts - 7/16-20	
Spare wheel (same or other) (a)		14x5 with stowaway spare; Regular wheel with remainder		

Drive Units—Tires And Wheels (Optional)

Size, load range, ply		FR78-14 (B/W, W/S & W/L opt.)	
Type (bias, radial, etc.)		Steel belted radial	
Wheel type & material		Rally-steel (w/RPO ZJ7)	Rally-steel (w/RPO F41)
Rim (size, flange type, and offset)		14x6; 0.50	14x7; 0.34
Size, load range, ply			
Type (bias, radial, etc.)			
Wheel type & material		Short spoke disc, steel (Reg.)	
Rim (size, flange type, and offset)		14x7; 0.34	
Size, load range, ply			
Type (bias, radial, etc.)			
Wheel type & material			
Rim (size, flange type, and offset)			
Size, load range, ply			
Type (bias, radial, etc.)			
Wheel type & material			
Rim (size, flange type, and offset)			
Size, load range, ply			
Type (bias, radial, etc.)			
Wheel type & material			
Rim (size, flange type, and offset)			

Brakes—Parking

Type of control		Foot pedal apply; 'T' handle release	
Location of control		Left of steering column under instrument panel	
Operates on		Rear service brakes	
If separate from service brakes	Type (internal or external)	---	
	Drum diameter	---	
	Lining size (length x width x thickness)	---	

(a) Stowaway spare tire standard with hatchback coupe; optional on remainder of mode

MVMA Specifications Form Passenger Car

Car Line Nova
 Model Year 1979 Issued 9/78 Revised (*) _____

U.S. Customary Units only.

Body Type And/Or Engine Displacement

4.1L RPO L22	L-6/1-8b1	5.0L RPO LG3	V-8/2-8b1	5.7L RPO LMI	V-8/4-8b1
-----------------	-----------	-----------------	-----------	-----------------	-----------

Brakes—Service

Brake Type (std., Opt., N.A.)	Drum	Front	N.A.		
		Rear	Standard		
	Disc	Front	Standard		
		Rear	N.A.		
Self-adjusting (std., opt., N.A.)			Standard		
Special Valving	Type (proportion, delay, metering, other)		Metering and proportioning		
Power Brake (std., opt., N.A.)			Optional	Standard	
Booster Type (remote, integral, vac., hyd., etc.)			Integral		
Anti-skid device type (std., opt., N.A.)			N.A.		
Effective area—cm ² (in. ²)*			100.5		
Gross lining area—cm ² (in. ²)**			115.6		
Swept area—cm ² (in. ²)***			326.4		
Rotor	Outer working diameter	F	11.0		
		R	--		
	Thickness	F	1.03		
		R	--		
	Material & type (vented/solid)	F	Cast iron, vented		
		R	--		
Drum	Diameter (nominal)	F	--		
		R	9.5		
Type and material			Composite, finned, cast iron		
Wheel cylinder bore	Front	2.9375			
	Rear	.9375			
Master Cylinder	Bore	Manual - 1.00; Power - 1.125			
	Stroke	Manual - 1.25; Power - 1.408			
Pedal arc ratio			Manual - 6.22:1; Power - 3.54:1		
Line pressure at 445 N (100 lb.) pedal load—MPa (psi)					
Lining Clearance Per Shoe	Front	Self adjusting			
	Rear	Self adjusting			
Brake lining	Front Wheel	Bonded or riveted, rivets/seg.		Riveted; 8	
		Rivet size		Front - .210x.379; Rear - .143x.250	
		Manufacturer		Delco Moraine	
		Lining Code		Inboard - GM 110FF; Outboard - GM 115FE	
		Material		Inboard - molded asbestos; Outboard-metallic asbestos	
		Prim. or out-board	5.40x 1.92x.465	
		Size	Second or in-board	5.40x 1.92x.465	
		Shoe thickness (no lining)		0.540	
	Rear Wheel	Bonded or riveted, rivets/seg.		Riveted; 10-primary, 12-secondary	
		Manufacturer		Delco Moraine	
		Lining Code		Primary - GM224 FF; Secondary - GM236 FF	
		Material		Molded asbestos	
		Prim. or out-board	7.30 x 2.0 x .23	
		Size	Second or in-board	9.46 x 2.0 x .23	
Shoe thickness (no lining)		Primary - .275; Secondary - .305			

* Excludes rivet holes, grooves, chamfers, etc.

** Includes rivet holes, grooves, chamfers, etc.

*** Total swept area for four brakes. (Drum brake: Widest lining contact width for each brake x its contact circumference.) (Disc brake: Square of Outer Working Dia. minus Square of Inner Working Dia. multiplied by $\pi/2$ for each brake.)

**** Size for drum brakes includes length x width x thickness.

MVMA Specifications Form Passenger Car

Car Line Nova
 Model Year 1979 Issued 9/78 Revised (*) _____

U. S. Customary Units only.

4.1L L-6/1-Bb1 RPO L22	5.0L V-8/2-Bb1 RPO LG3	5.7L V-8/4-Bb1 RPO LM1
---------------------------	---------------------------	---------------------------

Steering

Manual (std., opt., N.A.)		Standard		
Power (std., opt., N.A.)		Optional		
Adjustable steering wheel (tilt, swing, other)	Type and description	Tilt, universally jointed steering shaft at base of steering wheel		
	(Std., opt., N.A.)	Optional		
Wheel diameter	Manual	15.0		
	Power	15.0		
Turning diameter m(feet)	Outside front	Wall to wall (l. & r.)	30.9	
		Curb to curb (l. to r.)	38.1	
	Inside rear	Wall to wall (l. to r.)	N.A.	
		Curb to curb (l. to r.)	N.A.	
Manual	Gear	Type	Semi-reversible, recirculating ball stud	
		Make	Saginaw Steering	
		Ratios	Gear 24.0:1 Overall 26.2:1	
	No. wheel turns (stop to stop)	4.99		
Power	Type (coaxial, linkage, etc.)	Integral gear and power piston with vane type pump		
	Make	Saginaw Steering		
	Gear	Type	Same as manual	
		Ratios	Gear 16.0 Overall 16.0	
		Pump driven by	Crankshaft pulley	
No. wheel turns (stop to stop)	2.42			
Linkage	Type	Parallelogram		
	Location (front or rear of wheels, other)	Front		
	Drag links (trans. or longit.)	None		
	Tie rods (one or two)	Two		
Steering Axis	Inclination at camber (deg.)		10@ 0.75°	
	Bearings (type)	Upper	Ball stud with non-metallic bearings	
		Lower	Ball stud with non-metallic & sintered iron bearings	
		Thrust	None	
Steering spindle & joint type		Steering knuckle		
Wheel Spindle	Diameter	Inner bearing	1.25	
		Outer bearing	.844	
	Thread size	3/4-20		
Bearing type		Tapered roller		
Wheel Align at curb mass (wt.)	Service checking	Caster (deg.)	Manual - 2.0 to 0; Power - 0 to +2	
		Camber (deg.)	0 to +1.6	
		Toe-in (deg)	+0.05 to +.25	
	Service reset	Caster	Manual -1° + 0.5°; Power +1° + 0.5°	
		Camber	+0.8 + 0.5°	
		Toe-in	+ .15 ± .05°	
Periodic M.V. Inspection	Caster	Manual -3° to +1°; Power -1° to +3°		
	Camber	-0.7° to +2.3°		
	Toe-in	-.15 to +.55°		

MVMA Specifications Form Passenger Car

Car Line Nova
 Model Year 1979 Issued 9/78 Revised (*) _____

U.S. Customary Units only

Body Type And/Or Engine Displacement

4.1L L-6/1-Bb1 RPO L22	5.0L V-8/2-Bb1 RPO LG3	5.7L V-8/4-Bb1 RPO LM1
---------------------------	---------------------------	---------------------------

Suspension — General

(See Supplement page for details on Air Suspension)

Provision for car leveling	Front stabilizer bar	
Provision for brake dip control	Front suspension geometry	
Provision for acc. squat control	Front suspension geometry	
Special provisions for car jacking	Position jack in bumper slots on upper outboard face of front and rear bumpers.	
Shock absorber front & rear	Type	Direct, double acting, hydraulic
	Make	Delco
	Piston dia.	1.0
Other special features		

Suspension — Front

Type and description	Independent SLA type with coil springs	
Travel	Full Jounce	2.34
	Full Rebound	4.56
Spring	Type (coil, leaf, other)	Coil
	Material	Steel alloy
	Size (coil design height & I.D., bar length x dia.)	11.0x4.5; 116.07x.617(a)
	Spring rate — N/mm (lb./in.)	300(a)
	Rate at wheel — N/mm (lb./in.)	93
Stabilizer	Type (link, linkless, frameless)	Link
	Material & bar diameter	Steel-0.875 bias belted tires, base suspension & V-8 engines - also, L-6 engine with P/Stg. base suspension & bias belted tires.

Suspension — Rear

Type and description	Salisbury rear axle with multiple leaf springs	
Drive and torque taken through	Leaf springs	
Travel	Full Jounce	2.14
	Full Rebound	Left-5.70; Right-6.10
Spring	Type (coil, leaf, other)	Multiple Leaf
	Material	Chrome carbon steel
	Size (length x width, coil design height & I.D., bar length & dia.)	56.0x2.50
	Spring rate — N/m (lb./in.)	96(a)
	Rate at wheel — N/m (lb./in.)	106
	Mounting insulation type	Rubber bushed at shackle and hanger
	If leaf	No. of leaves
Stabilizer	Type (link, linkless, frameless)	Link (used only with PPO F41 Sport Suspension)
	Material & bar diameter	Steel - 0.5625
Track bar type	None	

(a) Ratios for base equipped model only. Springs for all models computer selected by size and rate according to vehicle weight including optional equipment.

**MVMA Specifications Form
Passenger Car**

Car Line Nova
 Model Year 1979 Issued 9/78 Revised (*) _____

U.S. Customary Units only.

Body Type		
2-Door Hatchback Coupe	2-Door Coupe	4-Door Sedan

Body — Miscellaneous Information

Type of finish (lacquer, enamel, other)	Acrylic Lacquer	
Hood counterbalanced (yes, no)	Yes	
Hood release control (internal, external)	External	
Vehicle Ident. No. Location	Top left hand of instrument panel pad	
Vent window control method (crank, friction pivot, power)	Front	None
	Rear	None
Seat cushion type	Front	Formed, foam pad
	Rear	Formed, foam pad
	3rd Seat	None
Seat back type	Front	Formed, foam pad
	Rear	Formed, foam pad
	3rd seat	None
Method of holding luggage compartment lid open	2-Door coupes and 4-door sedans, torsion rods: 2-Door hatchback coupe, hydropneumatic telescopic tubes.	
Position of spare tire storage	2-Door coupes and 4-door sedans, horizontal-center forward area of trunk floor.	
	2-Door hatchback coupe, horizontal-under cargo floor.	

Frame

Type and description (Separate frame, unitized frame, partially-unitized frame)	Body frame integral with separate partial frame.
---	--

**MVMA Specifications Form
Passenger Car**

Car Line Nova
 Model Year 1979 Issued 9/78 Revised (*) _____

U.S. Customary Units only.

Body Type		
2-Door Hatchback Coupe	2-Door Coupe	4-Door Sedan

Convenience Equipment

Power windows	Side Windows	Optional
	Vent windows	NA
	Backlight or tailgate	--
Power seats (specify type as well as availability)		NA
Reclining front seat back (R-L or both)		NA
Radios (specify type as well as availability)		Optional-AM Pushbutton, AM/FM Pushbutton, AM/FM Stereophonic, AM Stereo with 8-track tape, AM/FM stereo with 8-track or cassette tape, AM/FM Stereo with digital clock display.
Rear seat speaker		Optional
Power antenna		NA
Clock		Optional
Air conditioner (specify type)		Optional-Four season with manual control
Speed warning device		NA
Speed control device		Optional - with automatic transmission only.
Ignition lock lamp		NA
Dome lamp		Standard
Glove compartment lamp		Standard 1XY00 models-optional 1XX00 models
Luggage compartment lamp		Optional - Not available on 1XX17 model
Underhood lamp		Optional
Courtesy lamp		Optional (a) - standard(b)
Map lamp		NA
Cornering lamp		NA
Rear window defroster electrically heated		NA
Rear window defogger		Optional
Theft protection--type		Lock, mounted on steering column; locks Steering wheel, transmission, shift levers and ignition.

- (a) Instrument panel courtesy lamps.
- (b) Cargo area courtesy lamp for hatchback coupe.

MVMA Specifications Form
Passenger Car

Car Line Nova
 Model Year 1979 Issued 9/78 Revised (*) _____

U. S. Customary units only.

Equipment Differential Mass (Weights)	MASS, kg. (Weight, lb.)			Remarks
	Front	Rear	Total	
Air Conditioning	+61	+3	+64	With L6 engine
	+ 83	+ 3	+ 86	With V8 engine
Special contour				
Front bucket seat	- 2	- 2	- 4	1XY27 model only
Power windows	+ 6	+ 4	+ 10	2-Door models
	+ 12	+ 14	+ 26	4-Door models
Power steering	+ 30	0	+ 30	with L6 engine
	+ 28	0	+ 28	with V8 engine
Power brakes	+ 8	+ 1	+ 9	
Power Door locks	+ 4	+ 3	+ 7	2-door models
	+ 6	+ 7	+ 13	4-door models
Front compartment console	+ 3	+ 1	+ 4	with 3 & 4 speed transmission
	+ 7	+ 2	+ 9	with automatic transmission
Heavy duty Suspension				
Front & rear	+ 15	- 1	+ 14	
Sport suspension				
Front & rear	+ 28	- 3	+ 25	with V8 engine
Floor mats				
Front & rear	+ 4	+ 4	+ 8	
Battery-Heavy Duty	+16	-1	+15	
Rally wheel, hub cap & trim ring				
14x6 wheel	+ 7	+ 7	+ 14	Used with base & F40 suspension
14x7 wheel	+ 7	+ 11	+ 18	Used with F41 sport suspension
Wheel covers				
Simulated wire	+ 11	+ 11	+ 22	
Exterior soft trim				
Roof cover	+ 2	+ 4	+ 6	

* Also see Engine—General Section for dressed engine mass (weight).

MVMA Specifications Form

Passenger Car

Car Line Nova
 Model Year 1979 Issued 9/78 Revised (*)

U.S. Customary Units only.

Car and Body Dimension See Key Sheets, for definitions.

All dimensions to ground are for comparative purposes only. Dimensions are to be shown for all base body models of each car line.

SAE Ref. No. refers to the definition published in SAE Recommended Practice.

J1100a "Motor Vehicle Dimensions," unless otherwise specified.

SAE Ref. No.	Body Type		
	2-Door Hatchback	2-Door Coupe	4-Door Sedan

Width

Tread — Front	W101		61.3	
Tread — Rear	W102		59.0	
Vehicle width	W103		72.2	
Body width at S _g RP — front	W117	--		70.7
Vehicle width — front doors open	W120	144.8		127.7
Vehicle width — rear doors open	W121	--		126.5

Length

Wheelbase	L101		111.0	
Vehicle length	L103		196.7	
Overhang — front	L104		33.9	
Overhang — rear	L105		51.8	
Upper structure length	L123	101.0		96.8
Rear wheel C/L "X" coordinate	L127		93.0	
Cowl point "X" coordinate	L125		10.0	

Height*

Passenger Distribution (frt./rear)	PD1.2.3		2-3	
Trunk/Cargo load			0	
Vehicle height	H101	52.7		53.6
Cowl point to ground	H114		36.2	
Deck point to ground	H138			
Rocker panel front to ground	H112		8.1	
Bottom of door closed — front to grd.	H133	11.2		11.3
Rocker panel rear to ground	H111		7.2	
Bottom of door closed — rear to grd.	H135	--		10.3
Windshield slope angle	H122		53.5°	

Ground Clearance*

Front bumper to ground	H102		12.2	
Rear bumper to ground	H104		11.0	
Bumper to ground — front at curb mass (wt.)	H103		13.0	
Bumper to ground — rear at curb mass (wt.)	H105		14.4	
Angle of approach	H106		23°39'	
Angle of departure	H107		13°13'	
Ramp breakover angle	H147		13°24'	
Rear axle differential to ground	H153		6.6	
Min. running ground clearance	H156		4.6	
Location of min. run. grd. clear.			Frame to ground	

*All vehicle height and ground clearances are made at the Manufacturer's Design Load Weight, unless otherwise specified. Manufacturer's Design Load Weight is defined with indicated passenger distribution and trunk/cargo load.

MVMA Specifications Form

Passenger Car

Car Line Nova
 Model Year 1979 Issued 9/78 Revised (*)

U. S. Customary Units only.

Car and Body Dimensions See Key Sheets for definitions

SAE Ref. No.	Body Type		
	2-Door Hatchback Coupe	2-Door Coupe	4-Door Sedan

Front Compartment

Sg RP front, "X" coordinate	L31	42.6	
Effective head room	H61	38.2	39.1
Effective T Point head room	H75	38.4	39.3
Max. eff. leg room—accelerator	L34	41.7	
Sg RP—front to heel	H30	7.3	
Design H-point front travel	L17	4.7	
Shoulder room	W3	56.6	
Hip room	W5	53.3	
Upper body opening to ground	H50	48.2	49.1
Steering Wheel Angle	H18	22°	
Back Angle	L40	26.5°	

Rear Compartment

Sg RP Point couple distance	L50	30.8	32.7
Effective head room	H63	36.7	37.1
Effective T Point head room	H76	36.5	36.8
Min. effective leg room	L51	32.4	35.2
Sg RP—second to heel	H31	10.5	11.6
Knee clearance	L48	- 0.7	0.4
Compartment room	L3	24.2	25.4
Shoulder room	W4	55.3	56.7
Hip room	W6	52.8	53.6
Upper body opening to ground	H51	--	48.1

Luggage Compartment

Usable luggage capacity—L (cu. ft.)	V1	--	13.4	13.0
Liftover height	H195		27.4	

**MVMA Specifications Form
Passenger Car**

Car Line Nova
Model Year 1979 Issued 9/78 Revised (*)

U. S. Customary Units only.

Car and Body Dimensions See Key Sheets for definitions

SAE Ref. No.	Body Type 2-Door Hatchback Coupe
--------------------	--

Station Wagon — Third Seat

Shoulder room	W85	
Hip room	W86	
Effective leg room	L86	NOT APPLICABLE
Effective head room	H86	
Effective T Point head room	H89	
Seat facing direction	SD1	

Station Wagon — Cargo Space

Cargo length—open—front	L200	
Cargo length—open—second	L201	
Cargo length—closed—front	L202	
Cargo length—closed—second	L203	
Cargo length at belt—front	L204	
Cargo length at belt—second	L205	
Cargo width—wheelhouse	W201	
Rear opening width at floor	W203	NOT APPLICABLE
Opening width at belt	W204	
Max. rear opening width above belt	W205	
Cargo height	H201	
Rear opening height	H202	
Tail gate to ground height	H250	
Front seat back to load floor height	H197	
Cargo volume index—m ³ (ft. ³)	V2	
Hidden cargo volume—m ³ (ft. ³)	V4	

Hatchback — Cargo Space

Front seat back to load floor height	H197	14.4
Cargo length at front seat Back Height	L208	49.7
Cargo length at floor—front	L209	76.6
Cargo volume index—L (ft. ³)	V3	29.2
Hidden cargo volume—L (ft. ³)	V4	--

A printed or computer tape supplement containing additional car and body dimensions and/or drawings (based in part on SAE J1100a "Motor Vehicle Dimensions") may be available from the manufacturer.

MVMA Specifications Form

Passenger Car

Car Line Nova
 Model Year 1979 Issued 9/78 Revised (*) 2/79

U.S. Customary Units only.

Car and Body Dimensions See Key Sheets for definitions

Body Type		
2-Door Hatchback Coupe	2-Door Coupe	4-Door Sedan

Vehicle Fiducial Marks

Fiducial Mark Number*	Define Coordinate Location		
Front	X -	Fiducial mark to vertical body zero line-front, measured horizontally from the body zero line to the front fiducial mark located on top of the front seat adjuster mounting bolt.	
	Y -	Fiducial mark to centerline of car-front, width measurement made from centerline of car to fiducial mark located on top of the front seat adjuster mounting bolt.	
	Z -	Fiducial mark to horizontal body zero line- front, measured vertically from body zero line to front fiducial mark located on top of the front seat adjuster mounting bolt.	
Rear	X -	Fiducial mark to vertical body zero line-rear, measured horizontally from body zero line to the rear fiducial mark located on rear underbody crossbar.	
	Y -	Fiducial mark to centerline of car-rear, width measurement made from centerline of car to fiducial mark located on the rear underbody crossbar.	
	X -	Fiducial mark to horizontal body zero line-rear, measured vertically from body zero line to the rear fiducial mark located on rear underbody crossbar.	
Fiducial Mark Number			
Front	W21	Y-	22.70
	L54	X-	29.88
	H81	Z-	6.97
	H161		13.60
	H163		11.68
Rear	W22	Y-	22.50
	L55	X-	131.12
	H82	Z-	9.14
	H162		16.43
	H164		13.13

* Reference — SAE Recommended Practice, J182a, A Motor Vehicle Fiducial Marks — September, 1973.

MVMA Specifications Form

Passenger Car

Car Line Nova
 Model Year 1979 issued 9/78 Revised (*) _____

U. S. Customary Units only.

Car and Body Dimensions See Key Sheets for definitions

	SAE Ref. No.	Body Type		
		2-Door Hatchback Coupe	2-Door Coupe	4-Door Sedan
Glass			Base	Formal
Backlight slope angle	H121			
Windshield slope angle	H122		53.5°	
Tumble-Home	W122	21.0°		22.0°
Windshield glass exposed surface area—cm ² (in. ²)	S1	1209.3		1282.1
Side glass exposed surface area—cm ² (in. ²)	S2	1553.5	1350.4	1582.9
Backlight glass exposed surface area—cm ² (in. ²)	S3	1158.6	1392.1	1092.1
Total glass exposed surface area—cm ² (in. ²)	S4	3921.4	4154.9	3951.8
Windshield glass type		Curved-laminated plate		
Side glass type		Curved-tempered plate		
Backlight glass type		Curved-tempered plate		

Lamps and Headlamp Shape*

Height above ground to center of bulb or marker	Headlamp (H125)	Highest**	25.3
		Lowest	- -
	Tail (H126)	Highest	23.8
		Lowest	- -
	Sidemarker	Front	25.1
		Rear	20.5
Distance from C/L of car to center of bulb	Headlamp	Inside	- -
		Outside**	26.6
	Tail	Inside	- -
		Outside	25.7
	Directional	Front	18.5
		Rear	25.7
Headlamp Shape			Round

* Measured at curb mass (weight).

** If single headlamps are used enter here

MVMA Specifications Form Passenger Car

Exterior Car And Body Dimensions — Key Sheet

Exterior Width

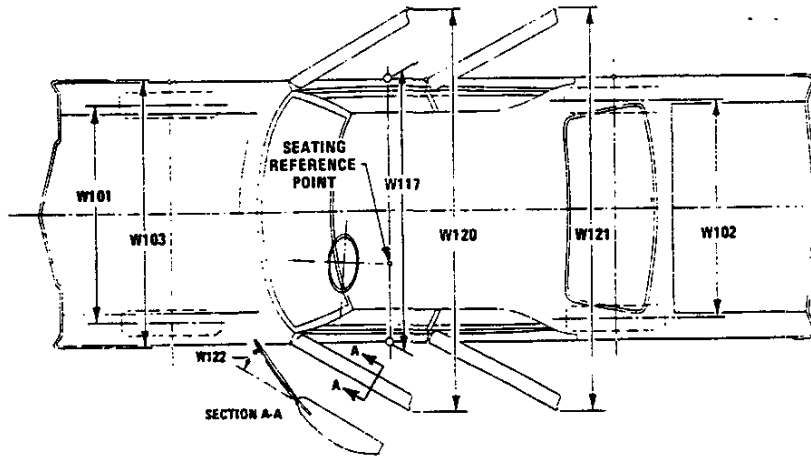

Exterior Length & Height

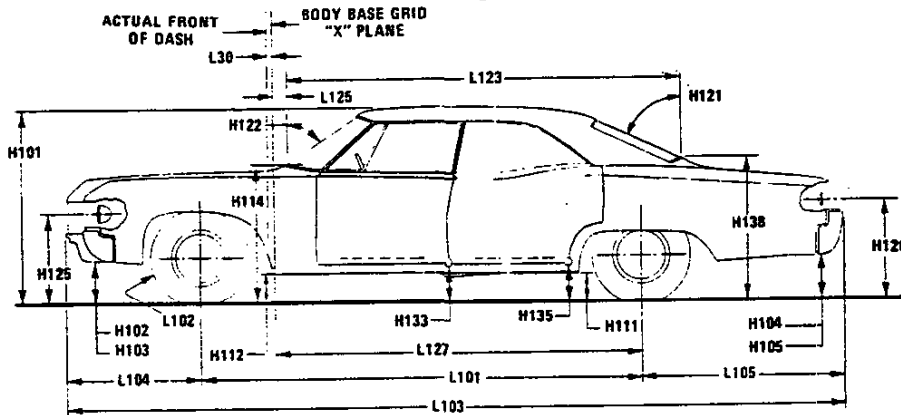

Exterior Ground Clearance

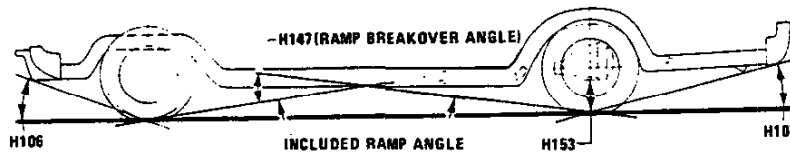

Cargo Space

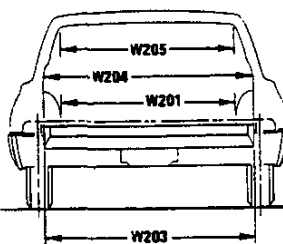
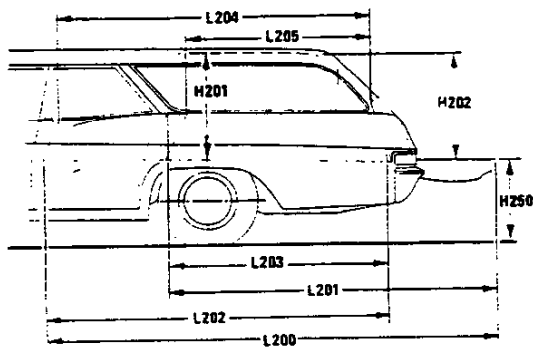

Station Wagon

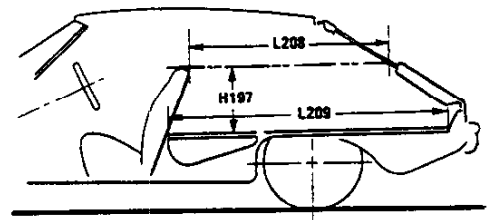

Hatchback

MVMA Specifications Form Passenger Car

Interior Car And Body Dimensions — Key Sheet

Front Compartment

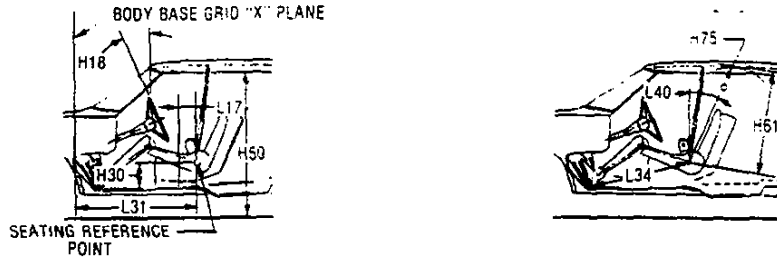

Rear Compartment

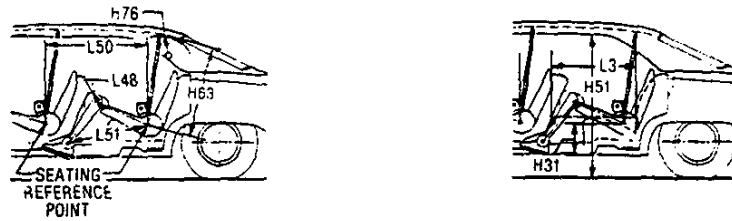

Third Seat

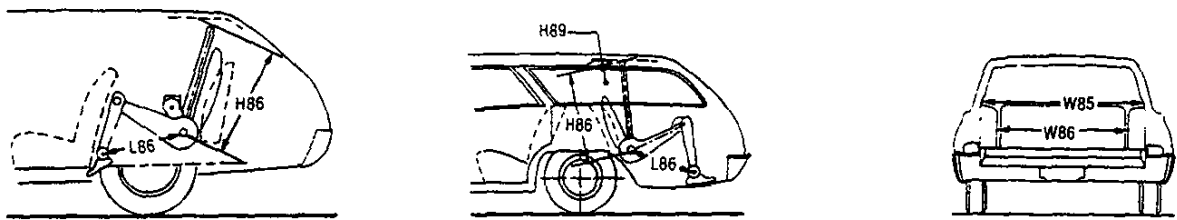

Interior Width

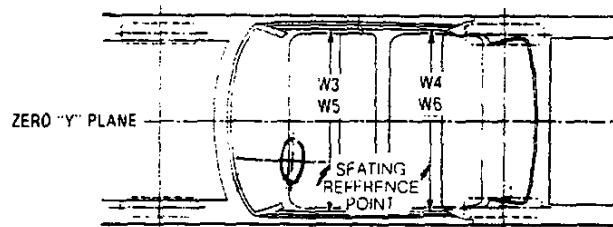

MVMA Specifications Form

Passenger Car

Exterior Car And Body Dimensions — Key Sheet

Dimension Definitions

Seating Reference Point

SEATING REFERENCE POINT means the manufacturer's design reference point which —

(a) Establishes the rearmost normal design driving or riding position of each designated seating position in a vehicle;

(b) Has coordinates established relative to the designed vehicle structure;

(c) Simulates the position of the pivot center of the human torso and thigh; and

(d) Is the reference point employed to position the two dimensional templates described in SAE Recommended Practice J826, "Manikins for Use in Defining Vehicle Seating Accommodations," November 1962.

Width Dimensions

- W101 TREAD — FRONT. The dimension measured between the tire centerlines at the ground.
- W102 TREAD — REAR. The dimension measured between the tire centerlines at the ground. In case of dual wheels, the dimension will be measured to the centerline of tire and wheel assemblies.
- W103 VEHICLE WIDTH. The maximum dimension measured between the widest point on the vehicle, excluding exterior mirrors, flexible mud flaps, marker lamps, but including bumpers, moldings, sheet metal protrusions or dual wheels, if standard equipment.
- W117 BODY WIDTH AT SgRP — FRONT. The dimension measured laterally between the widest points on the body at the SgRP - front, excluding door handles, applied moldings, or appliques.
- W120 VEHICLE WIDTH — FRONT DOORS OPEN. The dimension measured between the widest point on the front doors in maximum hold-open position.
- W121 VEHICLE WIDTH — REAR DOORS OPEN. The dimension measured between the widest point on the rear doors in maximum hold-open position. For vehicles with a rear door on only one side, this dimension is to the zero "Y" plane.
- W122 TUMBLE HOME, STRAIGHT SIDE GLASS. The angle measured from a vertical to the outside surface of the front door glass at the SgRP "X" plane.
CURVED SIDE GLASS. The angle measured from a vertical to a chord extending from the upper DLO to the lower DLO, at the outside surface of the front door glass at the front SgRP "X" plane.

Length Dimensions

- L30 FRONT OF DASH "X" COORDINATE. A minus (-) dimension indicates actual front of dash is forward of the zero "X" plane.
- L101 WHEELBASE (WB). The dimension measured longitudinally between front and rear wheel centerlines. In case of dual rear axles, the dimension shall be to the midpoint of the centerlines of the rear wheels.
- L102 TIRE SIZE. As specified by the manufacturer.
- L103 VEHICLE LENGTH. The maximum dimension measured longitudinally between the foremost point and the rearmost point on the vehicle, including bumper, bumper guards, tow hooks and/or rub strips, if standard equipment.
- L104 OVERHANG — FRONT. The dimension measured longitudinally from the centerline of the front wheels to the foremost point on the vehicle including bumper, bumper guards, tow hooks and/or rub strips, if standard equipment.

- L105 OVERHANG — REAR. The dimension measured longitudinally from the centerline of the rear wheels; or in the case of dual rear axles, the dimension shall be the midpoint of the centerlines of the rear wheels, to the rearmost point on the vehicle, including rear bumpers, bumper guards, tow hooks and rub strips, if standard equipment.
- L123 UPPER STRUCTURE LENGTH. The dimension measured longitudinally from the cowl point to the deck point.
- L127 REAR WHEEL CENTERLINE "X" COORDINATE or in the case of dual rear axles, the coordinate shall be in the midpoint of the distance between the rear axle centerlines.
- L125 COWL POINT "X" COORDINATE.

Height Dimensions

- H101 VEHICLE HEIGHT. The dimension measured vertically from the highest point on the vehicle body to ground.
- H114 COWL POINT TO GROUND. Measured at zero "Y" plane.
- H138 DECK POINT TO GROUND. Measured at zero "Y" plane.
- H112 ROCKER PANEL — FRONT TO GROUND. The dimension measured vertically from the foremost point on the bottom of the rocker panels, excluding flanges, to ground.
- H132 BOTTOM OF DOOR OPEN — FRONT TO GROUND. The dimension measured vertically from the bottom outside corner of the door on the lock pillar side, in maximum hold-open position, to ground.
- H111 ROCKER PANEL — REAR TO GROUND. The dimension measured vertically from the bottom of the rocker or side quarter panel at the front of the rear wheel opening, excluding flanges, to ground.
- H134 BOTTOM OF DOOR OPEN — REAR TO GROUND. The dimension measured vertically from the bottom outside corner of the door on the lock pillar side, in maximum hold-open position, to ground.
- H135 BOTTOM OF DOOR CLOSED — REAR TO GROUND. The dimension measured vertically from the bottom outside corner of the door on the lock pillar side, in maximum closed position, to ground.
- H121 BACKLIGHT SLOPE ANGLE. The angle between the vertical reference line and the surface of backlight at vehicle zero "Y" plane. For curve backlight, the angle is to chord of backlight arc from lower DLO to upper DLO.
- H122 WINDSHIELD SLOPE ANGLE. The angle between the vertical reference line and a chord of the windshield are running from the lower DLO to the upper DLO at the vehicle zero "Y" plane. In the case of wrap over glass, the angle to be measured will be formed by a chord 18.0 in. (457 mm) long, drawn from the lower DLO to the intersecting point on the windshield.
- H125 HEADLAMP TO GROUND. The dimension measured vertically from the centerline of the lowest headlamp lens to ground.
- H126 TAILLAMP TO GROUND. The dimension measured vertically from the centerline of the upper bulb to ground.
- Ground Clearance Dimensions**
- H102 FRONT BUMPER TO GROUND. The minimum dimension measured vertically from the lowest point on the front bumper to ground, including bumper guards, if standard equipment.

Passenger Car

Interior Car And Body Dimensions — Key Sheet
Dimension Definitions

- H103 FRONT BUMPER TO GROUND — CURB WEIGHT. Measured in the same manner as H104.
- H104 REAR BUMPER TO GROUND. The minimum dimension measured vertically from the lowest point on the rear bumper to ground, including bumper guards, if standard equipment.
- H105 REAR BUMPER TO GROUND — CURB WEIGHT. Measured in the same manner as H104.
- H106 ANGLE OF APPROACH. The angle measured between a line tangent to the front tire static loaded radius and the initial point of structural interference forward of the front tire to ground. The limiting structural component shall be designated.
- H107 ANGLE OF DEPARTURE. The angle measured between a line tangent to the rear tire static loaded radius and the initial point of structural interference rearward of the rear tire to ground. The limiting component shall be designated.
- H147 REAR BREAKOVER ANGLE. The angle measured between two lines tangent to the front and rear tire static loaded radius and intersecting at a point on the underside of the vehicle which defines the largest ramp over which the vehicle can roll.
- H153 REAR AXLE DIFFERENTIAL TO GROUND. The minimum dimension measured from the rear axle differential to ground.
- H156 MINIMUM RUNNING GROUND CLEARANCE. The minimum dimension measured from the sprung vehicle to ground. Specify location.

Front Compartment Dimensions

- PD1 PASSENGER DISTRIBUTION — FRONT.
- L31 SgRP — FRONT "X" COORDINATED.
- H61 EFFECTIVE HEAD ROOM — FRONT. The dimension measured along a line 8 deg rear of vertical from the SgRP - front to the headline, plus 4.0 in. (102 mm).
- H75 EFFECTIVE T-POINT HEAD ROOM — FRONT. The minimum radius from the T-point to the headlining plus 30 in. (762 mm).
- L34 MAXIMUM EFFECTIVE LEG ROOM — ACCELERATOR. The dimension measured along a line from the ankle pivot center to the SgRP - front plus 10.0 in. (254 mm) measured with right foot on the undepressed accelerator pedal. For vehicles with SgRP to heel (H30) greater than 18 in., the accelerator pedal may be depressed as specified by the manufacturer. If the accelerator is depressed, the manufacturer shall place foot flat on pedal and note the depression of the pedal.
- H30 SgRP — FRONT TO HEEL. The dimension measured vertically from the SgRP - front to the accelerator heel point.
- L17 DESIGN H-POINT — FRONT TRAVEL. The dimension measured horizontally between the design H-point - front in the foremost and rearmost seat track positions.
- W3 SHOULDER ROOM — FRONT. The minimum dimension measured laterally between the trimmed surfaces on the "X" plane through the SgRP - front within the belt line and 10.0 in. (254 mm) above the SgRP - front.
- W5 HIP ROOM — FRONT. The minimum dimension measured laterally between the trimmed surfaces on the "X" plane through the SgRP - front within 1.0 in. (25 mm) below and 3.0 (76 mm) above the SgRP - front and 3.0 (76 mm) fore and aft of the SgRP - front.
- H150 UPPER BODY OPENING TO GROUND — FRONT. The dimension measured vertically from the trimmed body opening to the ground on the SgRP - front "X" plane.
- H18 STEERING WHEEL ANGLE. The angle measured from a vertical to the surface plane of the steering wheel.

- L40 BACK ANGLE — FRONT. The angle measured between a vertical line through the SgRP - front and the torso line. If the seatback is adjustable use the normal driving and riding position specified by the manufacturer.

Rear Compartment Dimensions

- PD2 PASSENGER DISTRIBUTION — SECOND.
- L50 SgRP COUPLE DISTANCE. The dimension measured horizontally from the driver SgRP - front to the SgRP - second.
- H63 EFFECTIVE HEAD ROOM — SECOND. The dimension measured along a line 8 deg rear of vertical from the SgRP - second to the headlining, plus 4.0 in. (102 mm).
- H76 EFFECTIVE T-POINT HEAD ROOM — SECOND. Measured in the same manner as H75.
- L51 MINIMUM EFFECTIVE LEG ROOM — SECOND. The dimension measured along a line from the ankle pivot center to the SgRP - second plus 10.0 in. (254 mm).
- H31 SgRP — SECOND TO HEEL. The dimension measured vertically from the SgRP - second to the two dimensional device heel point on the depressed floor covering.
- L48 KNEE CLEARANCE — SECOND. The minimum dimension measured from the knee pivot to the back of front seatback minus 2.0 in. (51 mm).
- L3 COMPARTMENT ROOM — SECOND. The dimension measured horizontally from the back of front seat to the front of the second seatback at a height tangent to the top of the second seat cushion.
- W4 SHOULDER ROOM — SECOND. The minimum dimension measured laterally between trimmed surfaces on the "X" plane through the SgRP - second within 10.0-16.0 in. (254-406 mm) above the SgRP - second.
- W6 HIP ROOM — SECOND. Measured in the same manner as W5.
- H51 UPPER BODY OPENING TO GROUND — SECOND. The dimension measured vertically from the trimmed body opening to the ground on the "X" plane 13.0 in. (330 mm) forward of the SgRP - second.

Luggage Compartment Dimensions

- V1 USABLE LUGGAGE CAPACITY — Total of volumes of individual pieces of standard luggage set plus boxes stowed in the luggage compartment in accordance with the procedure described in paragraph 8.2 of SAE-J1100A.
- H195 LIFTOVER HEIGHT. The dimension measured vertically from the luggage compartment lower opening at the zero "Y" plane to ground.

Station Wagon - Third Seat Dimensions

- PD3 PASSENGER DIRECTION — THIRD.
- W85 SHOULDER ROOM — THIRD. Measured in the same manner as W5.
- W86 HIP ROOM — THIRD. Measured in the same manner as W5.
- L86 EFFECTIVE LEG ROOM — THIRD. The dimension measured along a line from the ankle pivot center to the SgRP - third plus 10.0 in. (254 mm).
- H86 EFFECTIVE HEAD ROOM — THIRD. The dimension measured along a line 8 deg from the SgRP - third to the headlining rear of vertical plus a constant of 4.0 in. (102 mm).
- H89 EFFECTIVE T-POINT HEAD ROOM — THIRD. Measured in the same manner as H75.

Station Wagon - Cargo Space Dimensions

- L200 CARGO LENGTH — OPEN — FRONT. The minimum dimension measured longitudinally from the back of

MVMA Specifications Form

Passenger Car

Interior Car And Body Dimensions — Key Sheet

Dimension Definitions

- the front seatback at the height of the undepressed floor covering to the rearmost point on the undepressed floor covering on the open tailgate or cargo surface if the rear closure is a conventional door type tailgate, at the zero "Y" plane.
- L201 CARGO LENGTH — OPEN — SECOND. The dimension measured longitudinally from the back of the second seatback at the height of the undepressed floor covering to the rearmost point on the undepressed floor covering on the open tailgate or cargo floor surface if the rear closure is a conventional door type tailgate, at the zero "Y" plane.
- L202 CARGO LENGTH — CLOSED — FRONT. The minimum dimension measured horizontally from the back of the front seat at the height of the undepressed floor covering to the rearmost point on the undepressed floor covering on the closed tailgate or taildoor for station wagons, trucks and mpv's at the zero "Y" plane.
- L203 CARGO LENGTH — CLOSED — SECOND. The dimension measured horizontally from the back of the second seat at the height of the undepressed floor covering to the rearmost point on the undepressed floor covering on the closed tailgate or taildoor for station wagons, trucks and mpv's at the zero "Y" plane.
- L204 CARGO LENGTH AT BELT — FRONT. The minimum dimension measured horizontally from the back of the front seatback at the seatback top to the foremost normal surface of the closed tailgate or inside surface of the cab back panel at the height of the belt, on the zero "Y" plane.
- L205 CARGO LENGTH AT BELT — SECOND. The minimum dimension measured horizontally from the back of the second seatback at the seatback top to the foremost normal surface of the closed tailgate at the height of the belt, on the zero "Y" plane.
- W201 CARGO WIDTH — WHEELHOUSE. The minimum dimension measured laterally between the trimmed wheel housings at floor level. For any vehicle not trimmed, measure the sheet metal.
- W203 REAR OPENING WIDTH AT FLOOR. The minimum dimension measured laterally between the limiting interferences of the rear opening at floor level.
- W204 REAR OPENING WIDTH AT BELT. The minimum dimension measured laterally between the limiting interferences of the rear opening at belt height or top of pick up box.
- W205 REAR OPENING WIDTH ABOVE BELT. The minimum dimension measured laterally between the limiting interferences of the rear opening above the belt height.
- H201 CARGO HEIGHT. The dimension measured vertically from the top of the undepressed floor covering to the headlining at the rear wheel "X" coordinated on the zero "Y" plane.

- H202 REAR OPENING HEIGHT. The dimension measured vertically from the top of the undepressed floor covering to the upper trimmed opening on the zero "Y" plane with rear door fully open.
- H250 TAILGATE TO GROUND (CURB WEIGHT). The dimension measured vertically from the top of the undepressed floor covering on the lowered tailgate to ground on the zero "Y" plane.
- V2 STATION WAGON
Measured in inches:

$$\frac{W4 \times H201 \times L204}{1728} = \text{Ft.}^3$$
 Measured in mm:

$$\frac{W4 \times H201 \times L204}{10^9} = \text{m}^3 \text{ (cubic meter)}$$
- V4 HIDDEN CARGO VOLUME. As specified by the manufacturer.

Hatchback — Cargo Space Dimensions

- All hatchback cargo dimensions are to be taken with the front seat in full down and rear position, and the rear seat folded down. The hatchback door is in the closed position. (For electrically adjusted seats, see manufacturer's specifications for Design "H" Point).
- H197 FRONT SEATBACK TO LOAD HEIGHT. The dimension measured vertically from the horizontal tangent to the top of the seatback to the undepressed floor covering.
- L208 CARGO LENGTH AT FRONT SEATBACK HEIGHT. The minimum horizontal dimension from the "X" plane tangent to the rearmost surface of the driver's seatback to the inside limiting interference of the hatchback door on the vehicle zero "Y" plane.
- L209 CARGO LENGTH AT FLOOR — FRONT — HATCHBACK. The minimum horizontal dimension measured at floor level from the rear of the front seatback to the normal limiting interference of the hatchback door on the vehicle zero "Y" plane.
- V3 HATCHBACK.
Measured in inches:

$$\frac{L208 + L209}{2} \times W4 \times H197$$

$$\frac{\quad}{1728} = \text{Ft.}^3$$
 Measured in mm:

$$\frac{L208 + L209}{2} \times W4 \times H197$$

$$\frac{\quad}{10^9} = \text{m}^3 \text{ (cubic meter)}$$

MVMA Specifications Form Passenger Car

Index

Subject	Page No.	Subject	Page No.
Alternator.....	12	Lamps and Headlamp Shape.....	30
Automatic Transmission.....	16	Legroom.....	27,28
Axis, Steering.....	20	Lengths — Car and Body.....	26
Axle, Rear.....	2,16	Lifters, valve.....	6
Battery.....	12	Linings — Clutch, Brake.....	15,19
Bearings, Engine.....	4,5,7	Lubrication.....	7,15,16,17
Belts — Fan, Generator, Water Pump.....	9	Luggage Compartment.....	27
Brakes — Parking, Service.....	18,19	Mass.....	27,28
Camber.....	20	Models.....	1
Camshaft.....	5	Motor, Starting.....	15
Capacities.....		Muffler.....	10
Cooling System.....	12	Passenger Capacity.....	1
Fuel Tank.....	8	Passenger Mass Distribution.....	24
Lubricants.....		Piston Pins & Rings.....	3,4
Engine Crankcase.....	7	Pistons.....	3,4
Transmission.....	15,16	Power Brakes.....	19
Rear Axle.....	16	Power Engine.....	2
Car Models.....	1	Power Steering.....	20
Car and Body Dimensions.....		Power Teams.....	2
Width.....	26	Propeller Shaft, Universal Joints.....	17
Length.....	26	Pumps — Oil, Fuel.....	7,8
Height.....	26	Water.....	9
Ground Clearance.....	26	Radiator — Cap, Hoses.....	9
Front Compartment.....	27	Ratios — Axle.....	2,16
Rear Compartment.....	27	Compression.....	2,3
Luggage Compartment.....	27	Steering.....	20
Station Wagon — Third Seat.....	28	Transmission.....	15,16
Station Wagon — Cargo Space.....	28	Rear Axle.....	2,16
Hatchback — Cargo Space.....	28	Regulator — Generator.....	12
Carburetor.....	2,8,11	Rims.....	18
Caster.....	20	Rings, Piston.....	4
Choke, Automatic.....	8	Rods — Connecting.....	4
Clutch — Pedal Operated.....	15	Seats.....	22
Coil, Ignition.....	14	Shock Absorbers, Front & Rear.....	21
Connecting Rods.....	4	Spark Plugs.....	14
Convenience Equipment.....	23	Speedometer.....	14
Cooling System.....	9	Springs — Front & Rear Suspension.....	21
Crankshaft.....	5	Stabilizer (Sway Bar) — Front & Rear.....	21
Cylinders and Cylinder Head.....	3	Starting System.....	12
Dimension Definitions.....		Steering.....	20
Key Sheet — Exterior.....	31,33	Suppression — Ignition, Radio.....	14
Key Sheet — Interior.....	32,34,35	Suspension — Front & Rear.....	21
Distributor — Ignition.....	13	Tail Pipe.....	7
Electrical System.....	12,13,14	Theft Protection.....	23
Emission Controls.....	10,11	Thermostat, Cooling.....	9
Engine.....		Timing — Valve, Ignition.....	6,13
Bore, Stroke, Type.....	3	Tires.....	18
Compression Ratio.....	2,3	Toe in.....	20
Displacement.....	2	Torque Converter.....	16
Firing Order, Cylinder Numbering.....	3	Torque — Engine.....	2
General Information, Power & Torque.....	2,3	Transmission — Types.....	2,8,15,16
Identification Number Location.....	22	Transmission — Automatic.....	2,8,15,16
Lubrication.....	7	Transmission — Manual.....	2,8,15
Power Teams.....	2	Transmission — Ratios.....	15,16
Exhaust System.....	7	Tread.....	26
Equipment Availability.....	24	Trunk Cargo Load.....	1
Fan, Cooling.....	9	Trunk Luggage Capacity.....	27
Fiducial Marks.....	29	Turning Diameter.....	20
Filters — Engine Oil, Fuel System.....	7,8	Unitized Construction.....	22
Frame.....	22	Universal Joints, Propeller Shaft.....	17
Front Suspension.....	21	Valves — Intake & Exhaust.....	6
Fuel, Fuel Pump, Fuel System.....	3,8,11	Vehicle Identification Number.....	22
Fuel Injection.....	8	Voltage Regulator.....	12
Generator and Regulator.....	12	Water Pump.....	9
Glass.....	30	Weights.....	24,25
Headroom — Body.....	27,28	Wheel Alignment.....	20
Heights — Car and Body.....	26	Wheelbase.....	26
Horns.....	14	Wheels & Tires.....	18
Horsepower — Brake.....	2	Wheel Spindle.....	20
Ignition System.....	13,14	Widths — Car and Body.....	26
Inflation — Tires.....	18	Windshield.....	30
Instruments.....	14	Windshield Wiper and Washer.....	14
Kingpin (Steering Axis).....	20		



4
7

