

9
5
2

Chevrolet

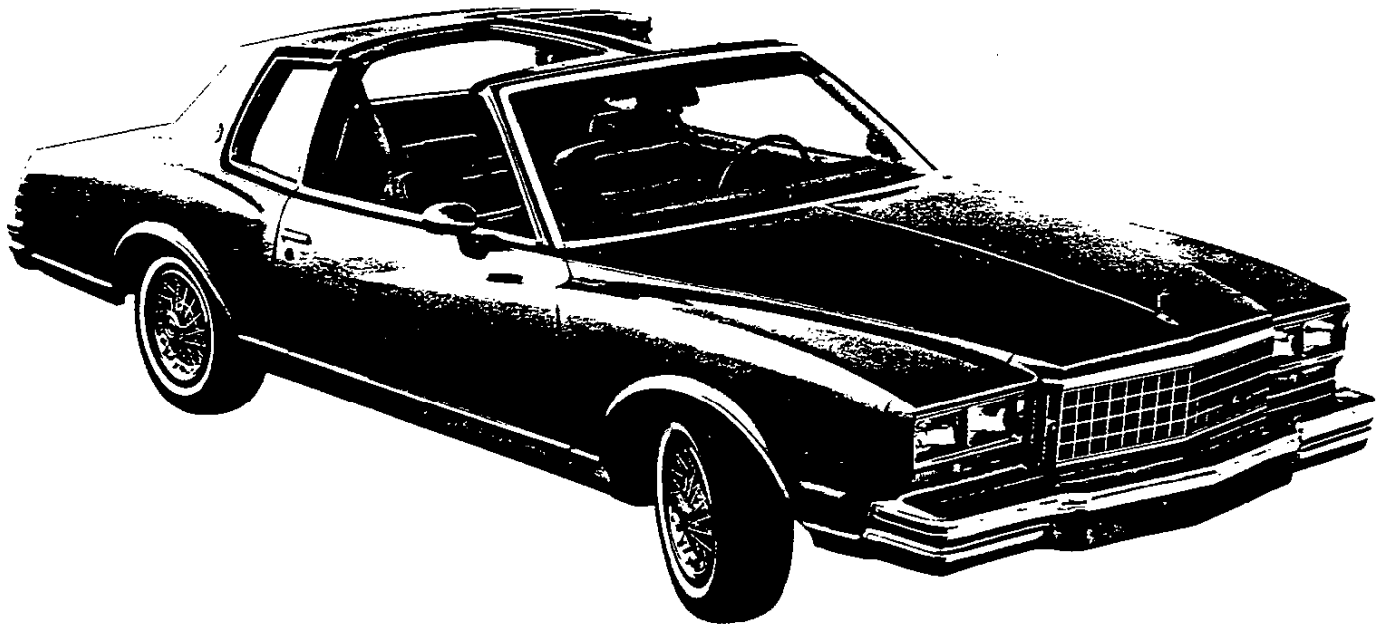

1980 Monte Carlo

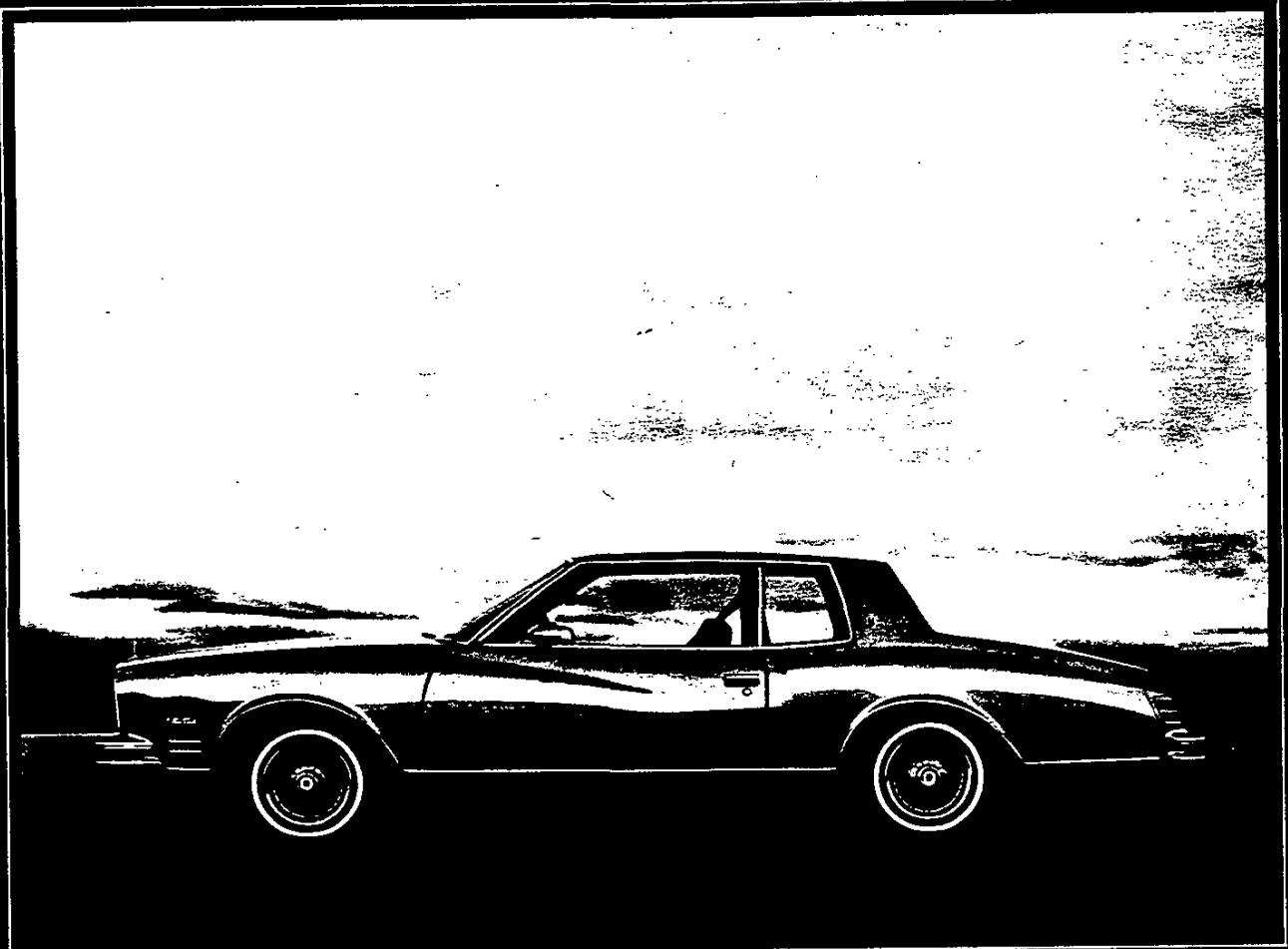

Monte Carlo 2-Door Sport Coupe

Monte Carlo. One beautiful car. And underneath it, beautiful engineering. Add it together and discover the unique package that's Monte Carlo.

For 1980 Monte Carlo continues that distinction. Its sweeping fenderline is impressive with a new grille and dual rectangular headlights. Inside there's added beauty in the rich new look of wood-grain on the instrument panel and new seat trim styling.

But beauty is as beauty does. And Monte Carlo acts the part with interior comfort and convenience features as well. The full foam seats let six people relax and there's room to enjoy — as much room inside as in the 1977 Monte Carlo — the one that was over a foot longer outside!

New engines are engineered to meet contemporary needs. A 3.8 Liter V6 engine is up 29 cubic inches over 1979. And a new option puts the power in your driving with an available turbocharged V6 engine that calls on extra power for merging, passing, hill climbing. Yet, it slows down when it's needed only for normal air-fuel mixture.

Road-tuned suspension system and

two stabilizer bars plus special rubber-cushioned body mountings on Monte Carlo's full-perimeter frame help isolate you from road noise and vibration.

Layers of sound-deadening material abound throughout the car. Padded acoustical ceiling soaks up sound overhead and one-piece cut-pile carpeting helps muffle it underfoot.

Monte Carlo is distinctive in looks and underneath it's backed up by solid Chevrolet engineering.

A beautiful car. And built to stay that way.

REASONS TO BUY MONTE CARLO

- Refined, elegant styling.
- Luxurious interior for comfort and convenience.
- Selection of V6, turbocharged V6 and V8 engines available.*
- Smooth, quiet ride with a responsive, road-tuned suspension system.
- Quality engineered and designed for value.

*Chevrolet cars are equipped with GM-built engines produced by various divisions. See your salesperson for details.

1980 MONTE CARLO



Landau Coupe

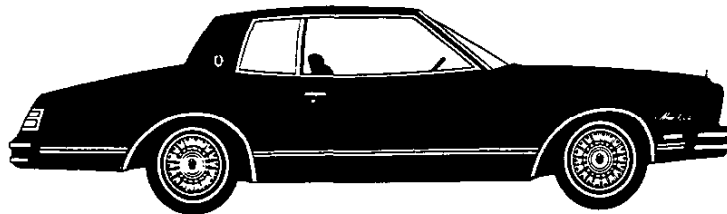

Sport Coupe

Monte Carlo	Model No.
Landau Coupe	1AZ37/Z03
Sport Coupe	1AZ37

Index

Monte Carlo Value Features for 1980	2-5	Equipment Summary	14-15
Monte Carlo Landau Coupe	6	Available Options	16-17
Monte Carlo Sport Coupe	7	Power Teams	18
Interior Features	8	Body/Chassis Features	19
Instrument Panel Features	9	Sound Deadening Features	20
Seat and Door Trim	10	Anti-Corrosion Measures	21
Color and Trim Combinations	11	Dimensions/Specifications	22
Vinyl Roof Covers and Colors	11	Color and Fabric Selector	23-26
Custom Two-Tone, Pin Striping and Body Side Molding Color Combinations	12-13		

Also see Value Features and Option Features sections for additional details.

See Dealer Order Guide for latest available information.

Monte Carlo/I

MONTE CARLO VALUE FEATURES FOR 1980

New Features for 1980 shown in Bold Face

ENGINE/CHASSIS

- **3.8 Liter 2-Bbl. V6 engine standard.** See Power Teams for availability
- **Turbocharged 3.8 Liter V6 engine available**
- **Automatic transmission standard**
- **Power steering standard**
- **Power disc/rear drum brake system standard**
- **Disc brake audible wear sensors indicate when linings need replacing standard**
- **Delcotron generator with built-in solid-state regulator standard**
- **Long recommended service intervals for oil change, oil filter, spark plugs, chassis lubrication and automatic transmission fluid**
- **Full-perimeter frame standard**
- **Visible ball joint wear indicators on front suspension lower control arms standard**
- **High Energy Ignition system standard**
- **Coolant recovery system helps prevent costly coolant loss standard**
- **GM Specification steel-belted radial ply tires standard**
- **Compact spare tire standard**
- **Early Fuel Evaporation systems on all engines for quick warm-up**
- **Delco Freedom battery that never needs refilling standard.** Sealed side terminals help prevent corrosion buildup
- **Full Coil suspension system**

with computer-selected springs *standard*

- **Front and rear stabilizer bars, standard**
- **Forward-mounted recirculating ball steering gear and linkage standard**
- **Dual horns standard**

BODY

- **Body by Fisher**
- **New "Monte Carlo" grille nameplate identification**
- **New large grid pattern grille**
- **New dual rectangular headlights**
- **New rectangular parking lights**
- **New hi-intensity, hi-beam headlights available in place of standard units for increased road illumination**
- **New rectangular front side marker lights**
- **Double-panel door, hood and deck lid construction standard**
- **High level acoustical quiet package standard**
- **Extensive anti-corrosion measures (see page 21)**
- **Flow-through ventilation system for passenger comfort standard**
- **Concealed dual-speed non-articulated electric windshield wipers standard**
- **Cushioned body mounting system (at 14 strategic points) effectively isolates passenger area from road noise and vibration**
- **Inner fenders front and rear for**

corrosion protection *standard*

INTERIOR

- **New instrument panel wood-grain treatment and revised cluster graphics**
- **Molded full foam seat construction standard**
- **Inside hood release for underhood security standard**
- **Color-keyed seat and shoulder belts standard**
- **Color-keyed cut-pile carpeting standard**
- **Electric clock standard**
- **Day/night inside rearview mirror standard**
- **Color-keyed steering column and steering wheel standard**
- **Glove compartment lock and light standard**

NEW OPTIONS

- **Hi-Intensity Hi-Beam Headlights RPO TT5**
- **Turbocharged 3.8 Liter 4-Bbl. (231 Cubic Inch) V6 engine RPO LC8**
- **Dual Front and Dual Rear Speakers .. RPO U92**
- **Value Appearance Package (Landau) ... RPO ZY8**
- **Value Appearance Package (Sport Coupe) RPO ZX5**
- **Custom Door and Quarter Trim Panels RPO ZY7**

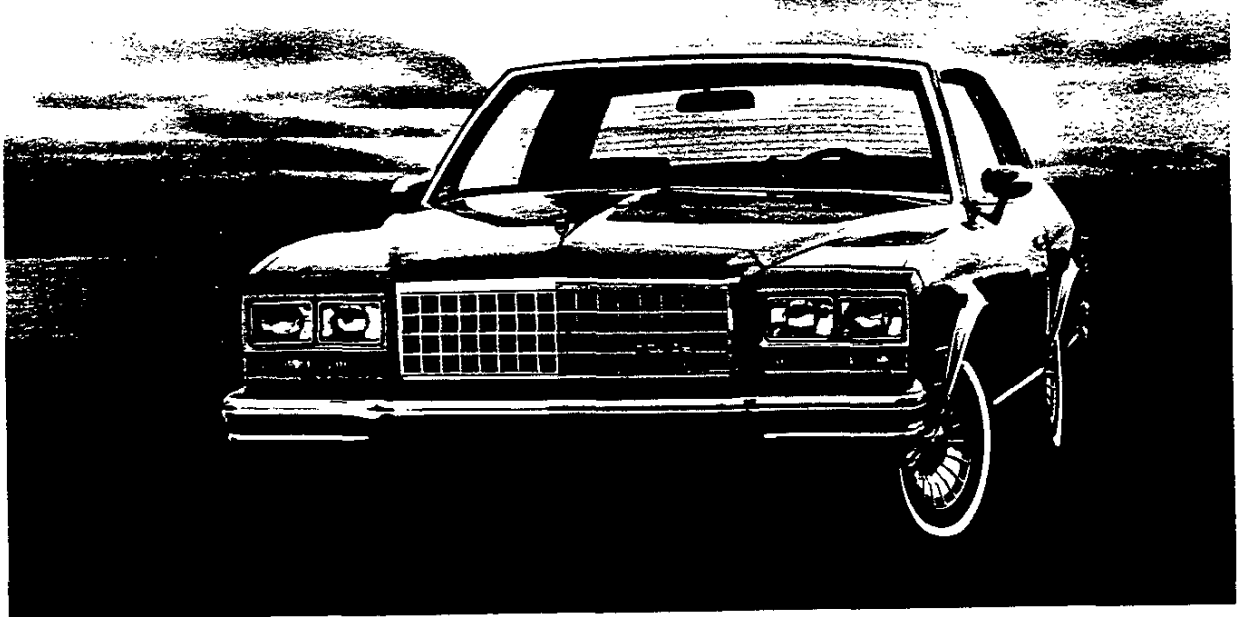

New Monte Carlo Front Styling Featuring New Grille, Dual Rectangular Headlights, Stand-Up Front Ornament and Body-Colored Bumper with Bright Accent Strips

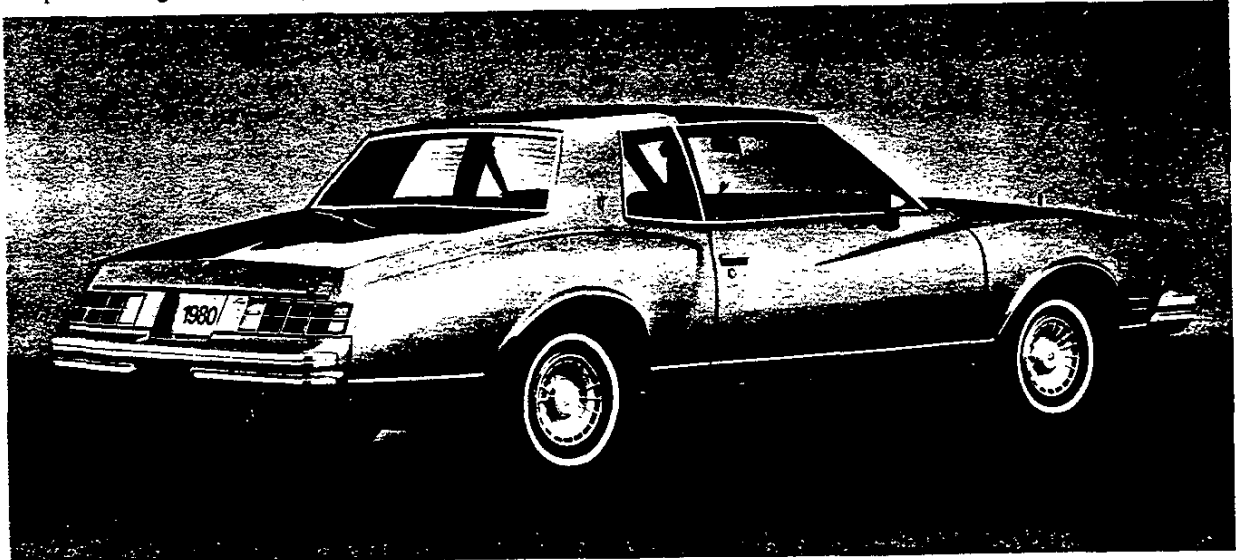

Monte Carlo Sport Coupe Shown with Available Removable Glass Roof Panels, Sport Mirrors, Bright Body Sill Moldings and White-Stripe Tires

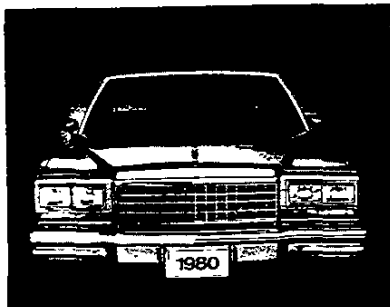

New Grille Styling and Dual Rectangular Headlights



Monte Carlo Four-Unit Taillights and Body-Colored Bumpers with Bright Accent Strips

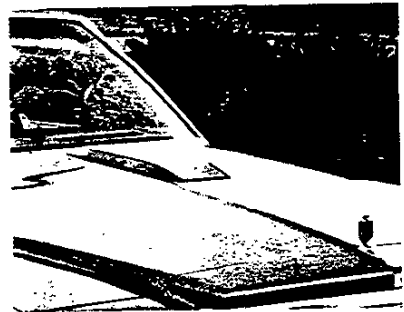

Special Hood With Available 3.8 Liter 4-Bbl. Turbocharged V6 Engine

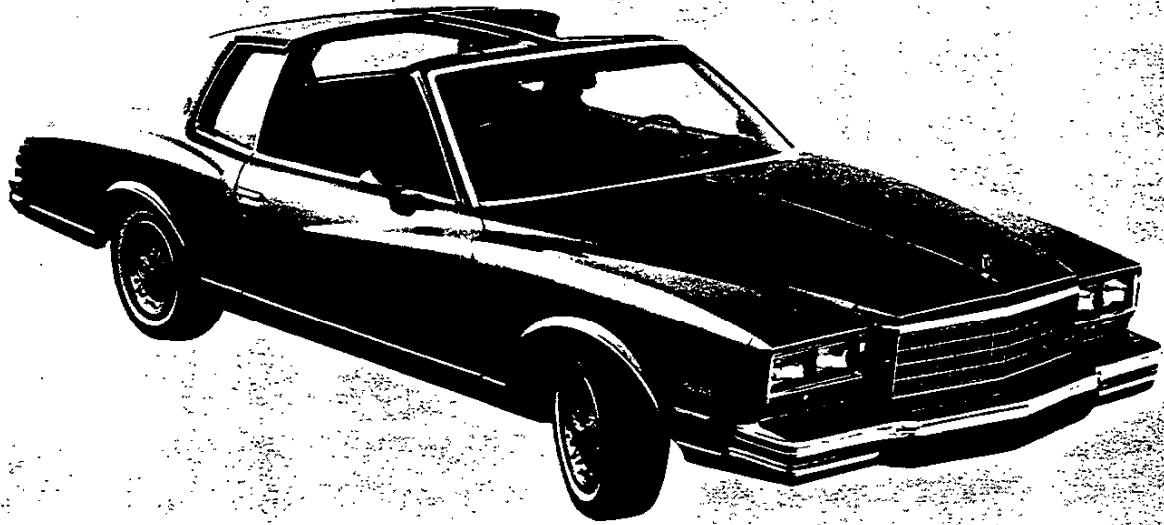

Monte Carlo Sport Coupe with Available Custom Two-Tone Paint, Removable Glass Roof Panels, Sport Mirrors, Wire Wheel Covers and Bright Body Sill Moldings

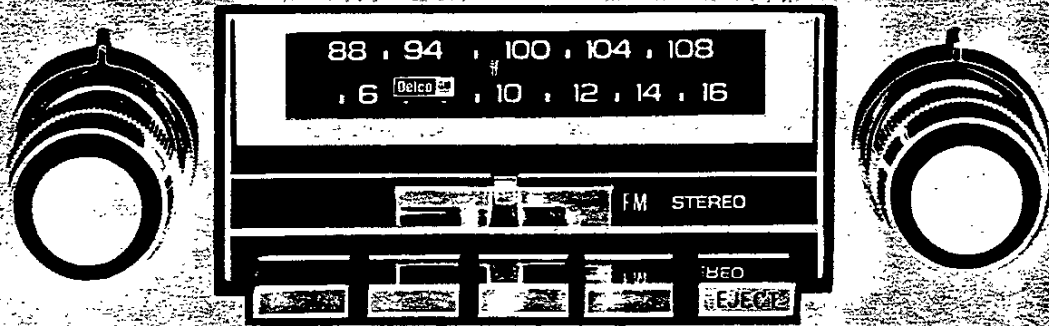

Available AM/FM Stereo Radio with 8-Track Stereo Tape

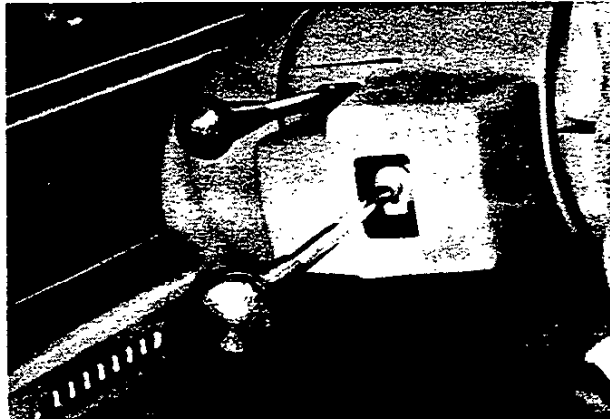

Column-Mounted Lever for Turn Signal and Headlight Dimmer
Standard

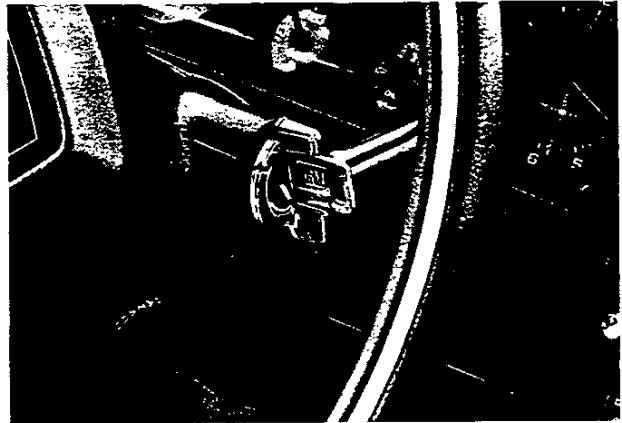

Anti-Theft Steering Column Lock *Standard*



Delco Freedom Battery *Standard*

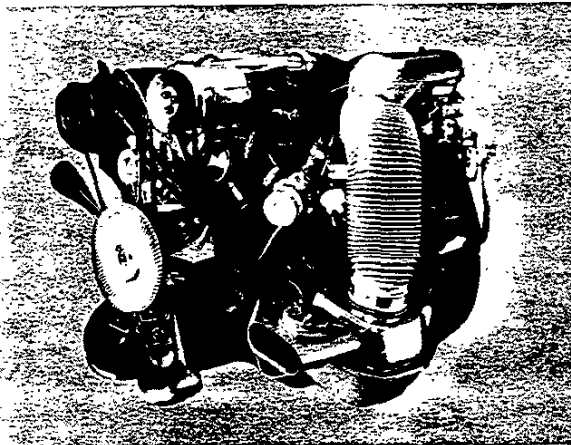

Available 3.8 Liter 4-Bbl. Turbocharged V6

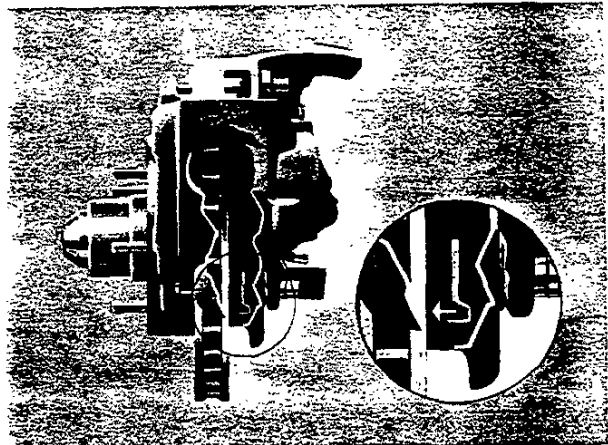

Front Disc Brake Audible Wear Sensor *Standard*

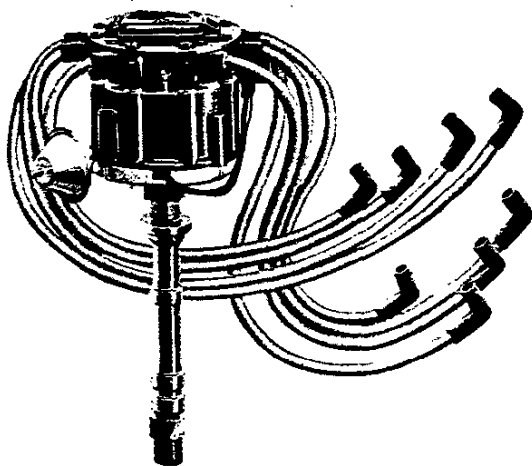

High Energy Ignition System *Standard*

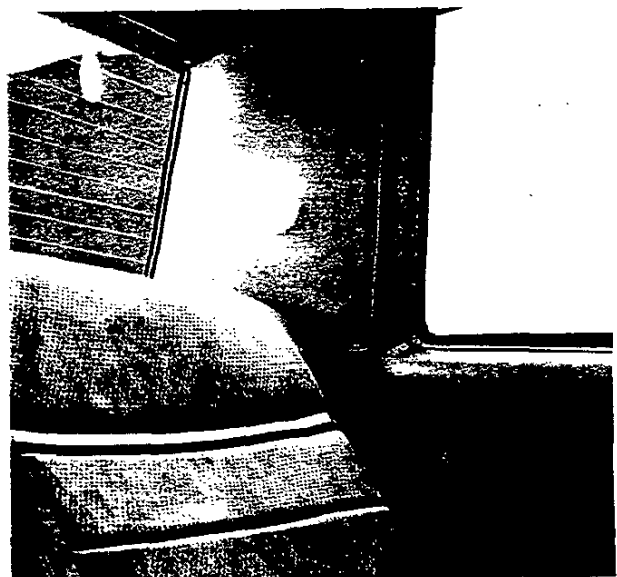

Rear Quarter Lights Included With Available Removable Glass Roof Panels

MONTE CARLO

Landau Coupe

Special Landau features shown in addition to Monte Carlo standard features. Landau also includes right-hand visor vanity mirror. Features shown in **bold face** are included in available Value Appearance Package (RPO ZY8) and are also available separately.

Vinyl Roof Cover
on Forward Portion
of Roof with
Bright Divider and Edge Molding

"Landau" Nameplate
and Crest

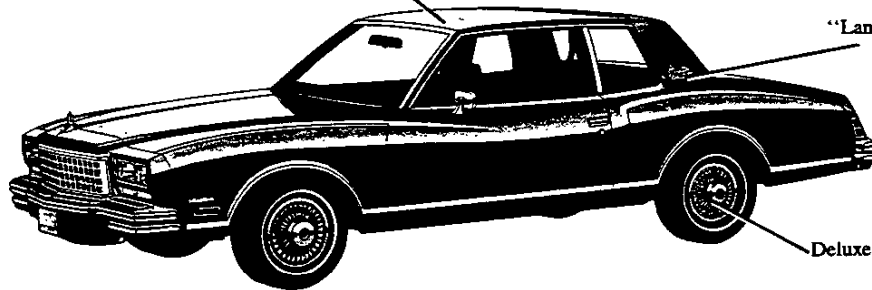

Deluxe Wheel Covers

Body-Colored Dual Sport Mirrors
(LH remote control, RH manual)

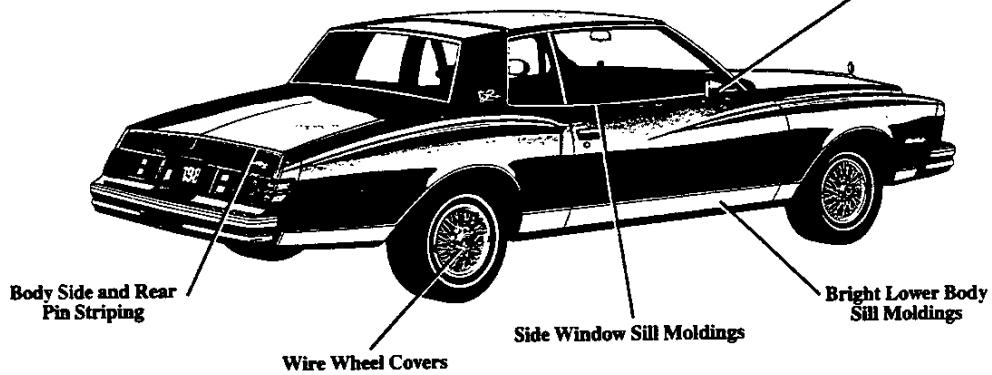

Body Side and Rear
Pin Stripping

Wire Wheel Covers

Side Window Sill Moldings

Bright Lower Body
Sill Moldings

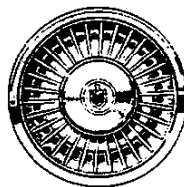

Standard Deluxe
Wheel Cover

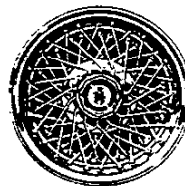

Available Wire Wheel
Cover (RPO N95)

MONTE CARLO

Sport Coupe

Features shown in bold face are included in available Value Appearance Package (RPO ZX5) and are also available separately.

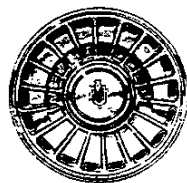
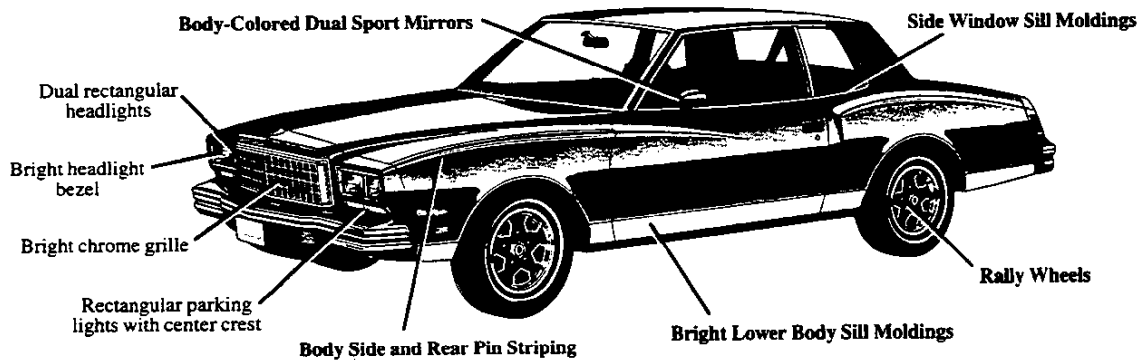
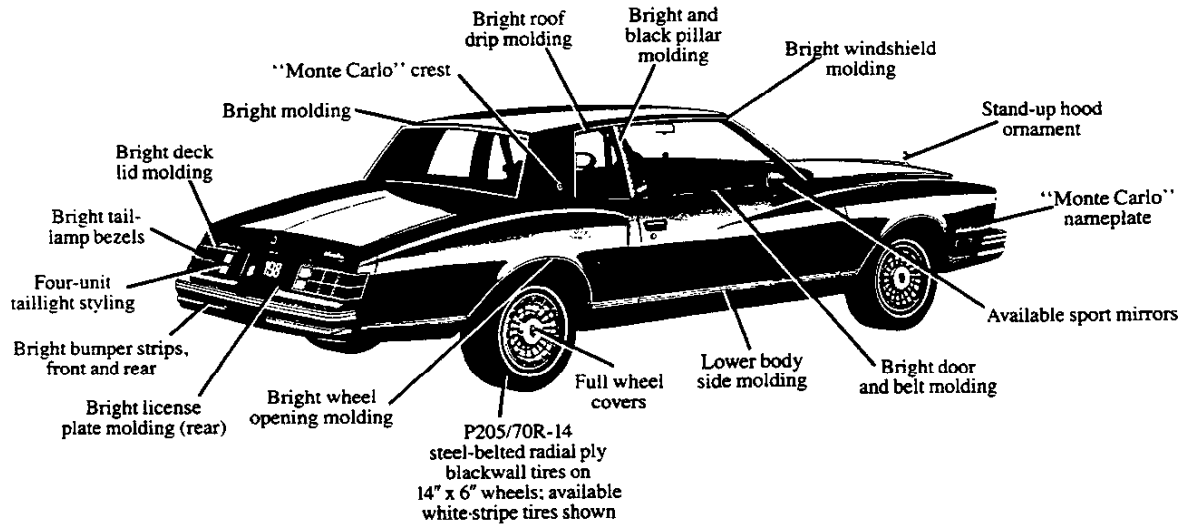

Standard Monte Carlo Wheel Cover



Available Rally Wheel (RPO ZJ7)

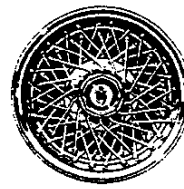

Available Wire Wheel Cover (RPO N95)

INTERIOR FEATURES



Monte Carlo Landau and Sport Coupe Available Special Custom Interior With 55/45 Seat and Folding Center Armrest.

INTERIOR FEATURES	Monte Carlo Landau	Monte Carlo
Conventional full-width front seat	S	S
Door panels with soft trim and integral armrests	S	S
Color-keyed carpeting in lower door panels	S	S
Vinyl door pull straps	S	S
Day/night rearview mirror	S	S
Visor mirror RH	S	EC
Color-keyed instrument panel, steering wheel, and column	S	S
Color-keyed seat and shoulder belts	S	S
Glove compartment lock and light	S	S
Automatic interior light switches on doors	S	S
Instrument panel courtesy lights	S	S
Cigarette lighter	S	S
Electric clock	S	S
Color-keyed one-piece cut-pile carpeting	S	S
Quiet Sound Group	S	S

S — Standard EC — Extra Cost

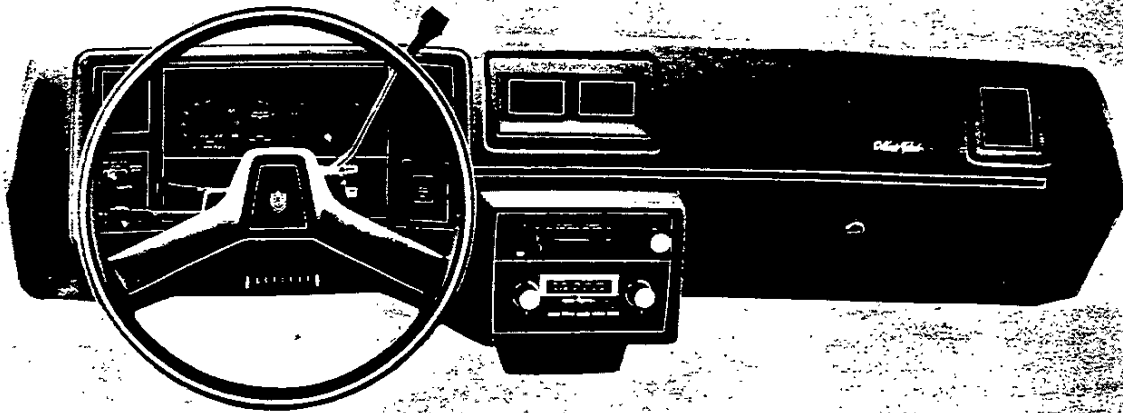

Monte Carlo Instrument Panel

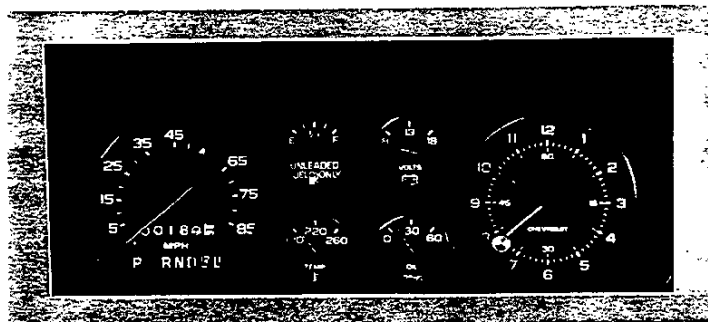

Available Gage Package (RPO UF7)

INSTRUMENT PANEL FEATURES	Monte Carlo Landau	Monte Carlo
Color-keyed instrument panel, steering wheel and column	S	S
Simulated wood-grain on panel pad and instrument cluster	S	S
Column-mounted turn signal and headlight dimmer	S	S
Cigarette lighter	S	S
Gage Package with tachometer includes voltmeter, temperature, oil pressure gages and simulated wood-grain accents	EC	EC
Gage Package includes voltmeter, temperature, and oil pressure gages and simulated wood-grain accents	EC	EC
85 mph/140 kph (kilometers per hour) speedometer	S	S
Electric clock	S	S
Soft-rim steering wheel with simulated wood-grain applique	S	S
Ashtray light	S	S
Glove compartment light	S	S
Instrument panel courtesy lights	S	S
Inside hood release	S	S
Glove compartment lock	S	S

S — Standard EC — Extra Cost

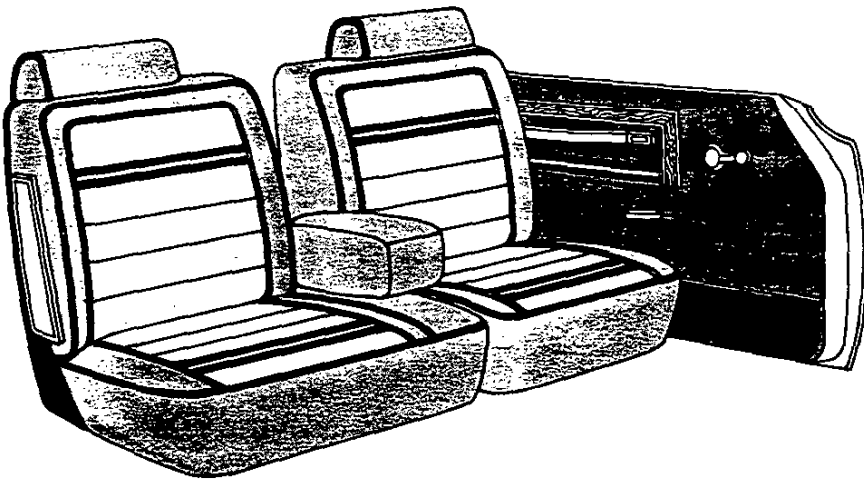

Monte Carlo Special Custom Interior 55/45 split seat with fold-down center armrest is available for Landau and Sport Coupe models. Special Custom cloth and Custom vinyl trims are available. Seat and door panel styling is new.

The oyster color vinyl interior comes with camel color carpet, cowl side panels, door pull strap facings and seat trim welts. Also, brown and cream color accent ribbons are used on seats, door trim panels and rear quarter trim panels. The instrument panel and rear compartment cover are gray with this interior.

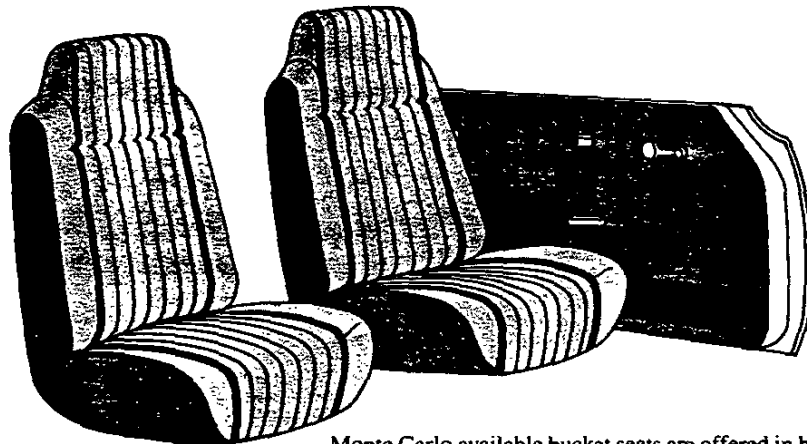

Monte Carlo available bucket seats are offered in both vinyl and cloth trims. Seat and door panel* styling is new. Available for Landau and Sport Coupe models.

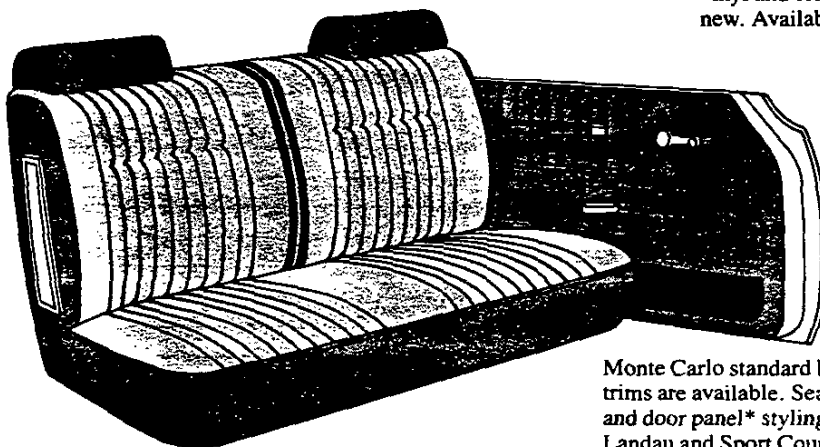

Monte Carlo standard bench seat. Both vinyl and cloth trims are available. Seat back is folding split type. Seat and door panel* styling is new. This seat is standard for Landau and Sport Coupe models.

NOTE: Illustrations show basic seat and door trim styling. Different tones of shading denote different materials (vinyl, cloth, carpet, wood-grain).

**Custom Door and Quarter Trim Panels (RPO ZY7) also available.*

COLOR AND TRIM COMBINATIONS

INTERIOR COLORS

		BLACK	BLUE	CAMEL	CLARET	GREEN	OYSTER	OYSTER/ CAMEL*
MONTE CARLO SPECIAL CUSTOM INTERIOR!								
Sport Coupe and Landau (55/45)	Special Custom Cloth		X	X	X	X	X	
	Special Custom Vinyl							X
MONTE CARLO								
Sport Coupe and Landau (Bench)	Cloth	X	X	X	X			
	Vinyl		X	X	X	X	X	
Sport Coupe and Landau (Bucket)	Cloth	X	X	X	X			
	Vinyl		X	X	X	X	X	

EXTERIOR COLORS	CODE	INT./EXT. COMB.	VINYL ROOF	INT./EXT. COMB.	VINYL ROOF	INT./EXT. COMB.	VINYL ROOF	INT./EXT. COMB.	VINYL ROOF	INT./EXT. COMB.	VINYL ROOF	INT./EXT. COMB.	VINYL ROOF
BEIGE	59	X	BB	X†		X	CC	X	RR	X†			
BLACK	19	X	BB	X	BB	X	BB†,CC	X	BB,RR	X	BB	X	QQ,BB
BLUE, DARK (MET.)	29	X	BB	X	DD,BB‡	X	CC				X	QQ	X†
BLUE, LIGHT (MET.)	21	X	BB,DD	X	DD,WW†						X	DD	
CAMEL, LIGHT (MET.)	63	X	CC			X	CC,WW†						
CAMEL, MEDIUM (MET.)	69	X	BB			X	CC						X†
CINNABAR	77	X	BB			X†					X	QQ	X†
CLARET (MET.)	75	X	BB					X	RR,WW†		X	QQ	
CLARET, DARK (MET.)	76	X	RR			X	CC,RR	X	RR,WW†		X	QQ,RR	X
GRAY	85	X	QQ	X	QQ	X	QQ	X	QQ,RR		X	QQ	X
GREEN, DARK (MET.)	44	X	GG			X	GG,CC			X	GG,WW†	X	GG
SILVER	15	X	BB	X				X	RR		X	BB	X†
WHITE	11	X	WW,BB	X	WW	X	WW,CC	X	WW,RR	X	WW	X	WW
YELLOW	50	X	BB			X†							

CUSTOM TWO-TONE (RPO D84) COLORS

BEIGE/CAMEL, LIGHT (MET.)						X	CC						
BLUE, DARK/BLUE, LIGHT (MET.'S.)				X	DD						X	DD	
CAMEL, LIGHT (MET.)/BLACK	X	BB				X	BB						X
CLARET/CLARET, DARK (MET.'S.)						X	RR	X	RR		X	RR	X
GRAY/CLARET, DARK (MET.)								X	RR		X	RR	X
SILVER/BLACK	X	BB						X	BB		X	BB	X
WHITE/GRAY	X	QQ						X	QQ		X	QQ	X

*Oyster with Camel accents: Camel carpeting, cowl side panels, door pull strap facings, seat trim welts; Gray instrument panel and rear seat back ledge; Brown and Cream accent ribbons on seats, doors and rear quarter panels. †Not available on Landau. ‡WW — White also available except on Landau.

STANDARD INTERIOR TRIM GUIDE • Cloth seat trim and bench seat standard on all models. • All other combinations are available options, including Vinyl trim on bucket seat. Vinyl trim on bucket seats or bucket seats with Cloth trim, and Special Custom Cloth trim with 55/45 seat.

VINYL ROOF COVERS

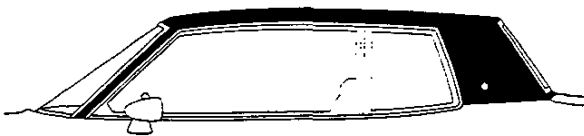

Full roof cover for Monte Carlo Sport Coupe. Available in Levant-grain vinyl in seven colors (top).

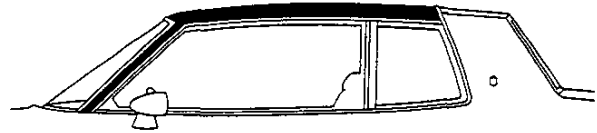

Landau roof cover standard on Monte Carlo Landau Coupe. Available in Elk-grain vinyl in seven colors (bottom).

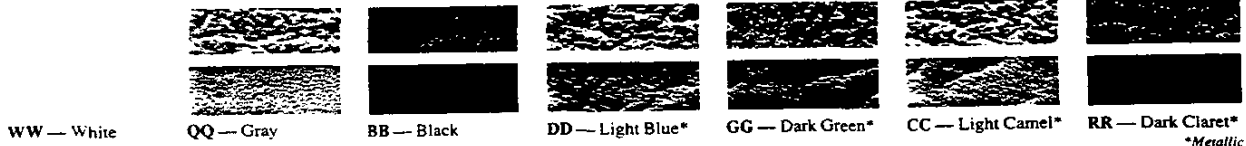

See Dealer Order Guide for latest available information.





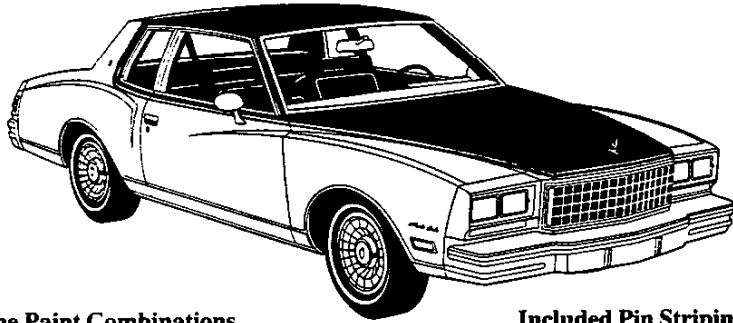

Monte Carlo/11

Custom Two-Tone Paint (RPO D84)





Two-Tone exterior paint with accent color on hood, roof and around side windows. Color-keyed pin striping separates the two colors. Available in choice of seven combinations. Available for all models.



Custom Two-Tone Paint Combinations

			
Beige with Camel, Light (Metallic) accent color	Blue, Dark (Metallic) with Blue, Light (Metallic) accent color	Camel, Light (Metallic) with Black accent color	Claret (Metallic) with Claret, Dark (Metallic) accent color
			
Gray with Claret, Dark (Metallic) accent color	Silver with Black accent color	White with Gray accent color	

Included Pin Striping Colors

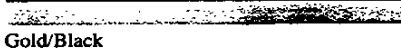
Red/Black

Claret/Silver

Silver/Blue

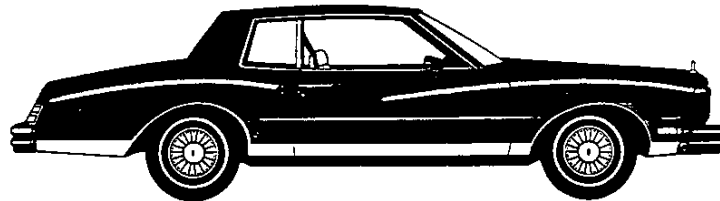
Gold/Brown

Gold/Black

Body Side Pin Striping (RPO D85)







On body sides, deck lid and fenders. Available in eight dual stripe colors keyed to exterior/interior colors. Available on all models; included with Value Appearance Packages for Landau Coupe (RPO ZY8) and Sport Coupe (RPO ZX5).



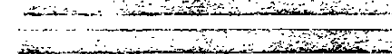



Body Side Moldings (RPO BW2)

Color-keyed upper and lower edges with bright vinyl insert. Available for all models, in six different colors keyed to exterior/interior colors.

Pin Striping Colors

	
White	Gold
	
Silver	Brown
	
Black	Red
	
Blue	Claret

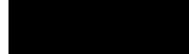
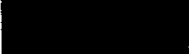
Molding Colors

	
White	Light Camel Metallic
	
Black	Dark Claret Metallic
	
Light Blue Metallic	Gray

**BODY PIN STRIPING AND DELUXE BODY SIDE MOLDING COMBINATIONS
WITHOUT RPO D84 CUSTOM TWO-TONE PAINT**

EXTERIOR COLOR	COLOR CODE	STRIPE MOLDING	INTERIOR TRIM COLOR						
			BLACK	BLUE	CAMEL	CLARET	GREEN	OYSTER	OYSTER/CAMEL
Beige	59		R Brown Lt Camel (Met)	R Brown Lt Camel (Met)	R Brown Lt Camel (Met)	R Claret Lt Camel (Met)	A Brown Lt Camel (Met)	NR Gold Lt Camel (Met)	NR Brown Lt Camel
Black	19		R Gold Black	R Blue Black	R Gold Black	R Red Black	R Gold Black	R Silver Black	R Silver Black
Blue, Dark (Met)	29		A Silver Black	R Blue Black	R Gold Black	NR Claret Black	NR Silver Black	A Silver Black	A Silver Black
Blue, Light (Met)	21		A Silver Lt Blue (Met)	R Silver Lt Blue (Met)	NR Silver Lt Blue (Met)	NR Silver Lt Blue (Met)	NR Silver Lt Blue (Met)	A Silver Lt Blue (Met)	NR Silver Blue
Camel, Light (Met)	63		A Brown Lt Camel (Met)	NR Black Lt Camel (Met)	R Brown Lt Camel (Met)	NR Claret Lt Camel (Met)	NR Black Lt Camel (Met)	NR Brown Lt Camel (Met)	NR Brown Lt Camel
Camel, Med (Met)	69		R Gold Lt Camel (Met)	NR Gold Lt Camel (Met)	R Brown Lt Camel (Met)	NR Gold Lt Camel (Met)	NR Gold Lt Camel (Met)	A Gold Lt Camel (Met)	A Gold Camel
Cinnabar	77		R Black Black	NR Black Black	R Gold Gray	NR Black Black	NR Black Black	R White Gray	R Gold Black
Claret (Met)	75		A Gold Dk Claret (Met)	NR Silver Dk Claret (Met)	NR Gold Dk Claret (Met)	R Gold Dk Claret (Met)	NR Gold Dk Claret (Met)	A Silver Dk Claret (Met)	NR Silver Claret
Claret, Dark (Met)	76		A Gold Dk Claret (Met)	NR Silver Dk Claret (Met)	R Gold Dk Claret (Met)	R Gold Dk Claret (Met)	NR Gold Dk Claret (Met)	R Silver Dk Claret (Met)	A Gold Claret
Gray	85		R Black Gray	R Blue Gray	A Brown Gray	R Claret Gray	NR Black Gray	R White Gray	R Brown Gray
Green, Dark (Met)	44		A Gold Black	NR Silver Black	R Gold Black	NR Silver Black	R Gold Black	A Silver Black	A Gold Black
Silver	15		R Black Gray	R Blue Gray	NR Black Gray	R Claret Gray	NR Black Gray	R Red Gray	R Black Gray
White	11		R Black White	R Blue White	R Gold White	R Claret White	R Gold White	R Red White	R Gold White
Yellow	50		R Black Black	NR Black Black	R Brown Gray	NR Black Black	NR Black Black	A White White	NR Brown Gray

R = Recommended Combinations
A = Acceptable Combinations

NR = Non-Recommended Combination
(Requires RPO D60 Non-Recommended Color Combination Option When Ordering)

WITH RPO D84 CUSTOM TWO-TONE PAINT (No Substitutes Allowed)

EXTERIOR COLOR	EXTERIOR COLOR CODE	ACCENT COLOR AND ORDERING CODE	STRIPE (INCLUDED)	SIDE MOLDING RPO BW2
Beige	59	Lt Camel (Met)	63M	Gold/Brown
Blue, Dark (Met)	29	Lt Blue (Met)	21M	Silver/Blue
Camel, Light (Met)	63	Black	19M	Gold/Brown
Claret (Met)	75	Dk Claret (Met)	76M	Gold/Black
Gray	85	Dk Claret (Met)	76M	Claret/Silver
Silver	15	Black	19M	Red/Black
White	11	Gray	85M	Claret/Silver

See Dealer Order Guide for latest available information.

EQUIPMENT SUMMARY

	Monte Carlo Landau Coupe	Monte Carlo Sport Coupe
EXTERIOR		
Large segment egg-crate grille	S	S
Bright windshield reveal molding	S	S
Dual rectangular headlights	S	S
Dual segment parking lights located below headlights with center crest	S	S
Body colored front and rear bumpers with bright accent strips	S	S
Sport mirrors LH remote & RH manual	EC	EC
Stand-up front end panel ornament	S	S
Bright roof drip molding	S	S
Bright rear quarter window molding	S	S
Bright and blue/gray lower body side molding	S	S
Bright, wide, lower body side molding with black painted rocker panel	EC	EC
Body side and rear pin striping	EC	EC
Wheel opening moldings	S	S
Wheel covers	NA	S
Deluxe wheel covers	S	EC
Landau vinyl roof cover	S	NA
Bright rear window reveal molding	S	S
Bright deck lid molding	S	S
Four-segment taillights	S	S
Trunk lock cover	S	S
INTERIOR		
Color-keyed seat & shoulder belts	S	S
Conventional full-width front seat	S	S
Bright front seat end panels	S	S
Door panels with soft trim and integral armrests	S	S
Vinyl door pull straps	S	S
Day/night rearview mirror	S	S
Visor mirror RH	S	EC
Center dome light	S	S
Color-keyed instrument panel, steering wheel, and column	S	S
Glove compartment lock and light	S	S
Instrument panel courtesy lights	S	S
Illuminated ashtray	S	S
Cigarette lighter	S	S
Electric clock	S	S
Color-keyed one-piece cut-pile carpeting	S	S
Luggage compartment mat	S	S
Dual horns	S	S
Quiet Sound Group	S	S

POWER TEAMS/CHASSIS/MECHANICAL	Monte Carlo Landau Coupe	Monte Carlo Sport Coupe
3.8 Liter 2-Bbl. V6 (229 cu. in.) engine	S	S
Automatic transmission	S	S
Power steering	S	S
Forward mounted recirculating ball steering gear and linkage	S	S
Power brakes	S	S
Front disc/rear drum brake system	S	S
Vented front disc brake rotors and finned rear brake drums	S	S
Disc brake audible wear sensors	S	S
P205/70R-14 steel-belted radial ply tires on 14" x 6" wheels	S	S
Tire wear indicators	S	S
Inside hood release	S	S
Concealed dual-speed electric windshield wipers	S	S
Dual mode flow-thru ventilation system	S	S
Delco Freedom battery with sealed side terminals	S	S
Delcotron generator with built-in solid-state regulator	S	S
Front and rear stabilizer bars	S	S
Full Coil suspension system	S	S
Independent coil-spring spherical joint front suspension (short and long arm type) with low-friction non-metallic spherical joint liners and built-in anti-dive control	S	S
Visible ball joint wear indicators on front suspension lower control arms	S	S
Four-link-type rear suspension with dual bias-mounted upper control arms and parallel-mounted lower control arms	S	S
Direct double-acting sealed-unit hydraulic shock absorbers	S	S
Heavy-gage steel roof panel with double-flanged channel-crossed reinforcing bows	S	S
Box-section design roof rails, windshield and rear window headers, door and roof panels	S	S
High-strength double-walled cowl unit-welded to instrument panel, floor and dash panel	S	S
All-welded heavy-gage steel body construction with cowl, roof, underbody, and body panels	S	S
Double panel door, hood, and deck lid	S	S
Counterbalanced hood, deck lid	S	S
Bolt-on front-end sheet metal cushion-mounted to frame and radiator support assembly	S	S
Full perimeter frame	S	S
Inner fenders front and rear	S	S
Cushioned body mounting system	S	S
Heavily ribbed and formed underbody with transverse stiffeners welded to underbody and body sills	S	S
Acoustical sound insulation	S	S
Long recommended service intervals for oil change, oil filter, spark plugs, chassis lubrication, and automatic transmission fluid	S	S

S — Standard EC — Extra Cost NA — Not Available

AVAILABLE OPTIONS

	RPO	Monte Carlo Landau Coupe	Monte Carlo Sport Coupe
Air Conditioning. Includes hood insulator. 63-Amp generator	C60	•	•
Axles:			
Performance Axle Ratio (Requires LG4 Engine)	G92	•	•
Limited Slip Differential. Includes Stowaway Spare Tire	G80	•	•
	UA1	•	•
Battery, Heavy-Duty	D55	•	•
Console. Requires Bucket Seats	D24	•	•
Container, Litter	V08	•	•
Cooling, Heavy-Duty			
Defogger, Electric Rear Window. Requires 70-Amp Generator without Air Conditioning	C49	•	•
Door Lock System, Power	AU3	•	•
Emission Equipment: See Power Teams for availability			
Standard Emission System	NA5	•	•
California Emission Requirements	YF5	•	•
Engines: See Power Teams for availability			
3.8 Liter 4-Bbl. Turbocharged V6	LC8	•	•
3.8 Liter 2-Bbl. V6. California only	LD5	•	•
4.4 Liter 2-Bbl. V8	L39	•	•
5.0 Liter 4-Bbl. V8	LG4	•	•
Floor Mats, Color-Keyed — Front & Rear	B37	•	•
Gage Package. Includes temperature, voltmeter and oil pressure gages	UF7	•	•
Gage Package with Tachometer. Includes voltmeter, temperature and oil pressure gages	U14	•	•
Generator, 70-Amp Delcotron. Not Available with Rear Defogger with Air Conditioning	K73	•	•
Glass, Tinted	A01	•	•
Headlights, Hi-intensity, Hi-beam	TT5	•	•
Lighting, Auxiliary. Includes automatic time-delay dome light, luggage compartment light, underhood light, and headlight reminder buzzer	TR9	•	•
Luggage Compartment Trim, Deluxe	B48	•	•
Mirrors:			
Remote Control Outside Rearview — LH	D33	NA	•
Sport, LH Remote & RH Manual. Included with Value Appearance Group	D35	•	•
Sport, Twin Remote	D68	•	•
Visor, RH	D34	S	•
Visor, Illuminated RH	D64	•	•
Moldings:			
Body Side, Deluxe. Color-keyed vinyl upper and lower edges	BW2	•	•
Door Edge Guards	B93	•	•
Side Window Sill. Included with Value Appearance Group	B85	•	•
Body Sill, Bright. Included with Value Appearance Group	BX2	•	•
Paint, Custom Two-Tone (See Color and Trim Selections)	D84	•	•

	RPO	Monte Carlo Landau Coupe	Monte Carlo Sport Coupe
Radio Equipment: (Note: Check Dealer Order Guide for other equipment included or required)			
AM Radio	U63	•	•
AM/FM Radio	U69	•	•
AM/FM Citizens Band Radio with Power Antenna. Requires rear seat speaker	UP5	•	•
AM/FM Stereo/Citizens Band Radio with Power Antenna	UP6	•	•
AM/FM Stereo Radio	U58	•	•
AM/FM Stereo Radio with 8-Track Stereo Tape	UM2	•	•
AM/FM Stereo Radio with Stereo Cassette Tape	UN3	•	•
AM Radio with 8-Track Stereo Tape	UM1	•	•
Speaker, Rear Seat. Available with AM, AM/FM or AM/FM Citizens Band Radios only	U80	•	•
Speakers, Dual Front and Dual Rear. Available with AM or AM/FM Radios only. Included with all stereo equipment	U92	•	•
Power Antenna. NA with Windshield Antenna	U75	•	•
Windshield Antenna. Included with factory-installed radio except Citizens Band. NA with Power Antenna	U76	•	•
Roof Cover, Vinyl (See Color and Trim Selections)	---	S	•
Roof Panels, Removable Glass. With tinted glass panels	CC1	NA	•
Seat Equipment:			
Six-Way Power Seat. NA with Bucket Seats; driver's side only with 55/45 seat	AG9	•	•
Bucket Seats (See Color and Trim Selections)	---	•	•
Sky Roof, Power. With sliding steel panel	CA1	•	•
Speed Control, Automatic	K30	•	•
Steering Wheel, Comfortilt	N33	•	•
Striping Pin, Body Side and Rear. NA with Custom Two-Tone Paint; Included with Value Appearance Group	D85	•	•
Suspension, Heavy-Duty Front & Rear. Includes higher rate front and rear springs and matching shock absorbers	F40	•	•
Tires:			
P205/70R-14 Steel-Belted Radial Ply White-Stripe	QFK	•	•
Trim, Interior: (See Color and Trim Selections)			
Special Custom Cloth Interior with 55/45 Seat	Z06	•	•
Custom Door and Quarter Trim Panels	ZY7	•	•
Vinyl Interior	---	•	•
Trunk Opener, Power	A90	•	•
Value Appearance Group Includes Side Window Sill Moldings, Wire Wheel Covers, Bright Body Sill Moldings, Dual Sport Mirrors and Body Side and Rear Pin Striping	ZY8	•	NA
Value Appearance Group Includes Side Window Sill Moldings, Body Side and Rear Pin Striping, Rally Wheels, Bright Body Sill Molding and Dual Sport Mirrors	ZX5	NA	•
Wheel Equipment:			
Rally Wheels Included with Value Appearance Group	ZJ7	NA	•
Wire Wheel Covers Included with Value Appearance Group on Landau	N95	•	•
Windows, Power	A31	•	•
Windshield Wiper System, Intermittent	CD4	•	•

S — Standard • — Available at extra cost NA — Not Available

See Options Section for Additional Details and Illustrations.

Monte Carlo/17

POWER TEAMS

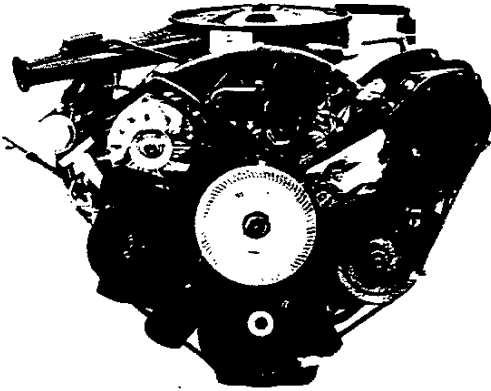

Standard 3.8 Liter 2-Bbl. V6 Engine

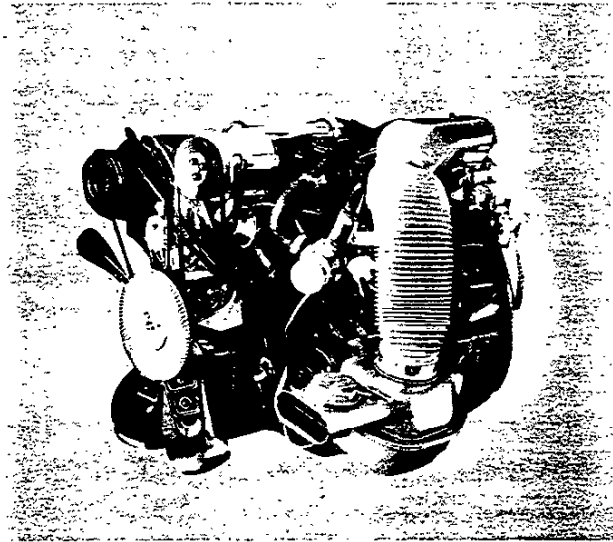

Available 3.8 Liter 4-Bbl. Turbocharged V6 engine

Engine	RPO No.	Power Rating*	Displacement (cubic inches)	Engine Availability	Automatic Transmission RPO MX1	Rear Axle Ratio
ALL STATES EXCEPT CALIFORNIA (with Standard Emission System — RPO NA5)						
3.8 Liter 2-Bbl. V6 (A)	LC3	115	229	Std.	Std.	2.41
3.8 Liter 4-Bbl. Turbocharged V6 (B)	LC8	170	231	EC	Std.	2.41
4.4 Liter 2-Bbl. V8 (C)	L39	120	267	EC	Std.	2.29
5.0 Liter 4-Bbl. V8 (C)	LG4	155	305	EC	Std.	2.29**

CALIFORNIA ONLY (with California Emission Requirements — RPO YF5)						
3.8 Liter 2-Bbl. V6 (B)	LD5	110	231	EC	Std.	2.41
3.8 Liter 4-Bbl. Turbocharged V6 (B)	LC8	170	231	EC	Std.	2.73
5.0 Liter 4-Bbl. V8 (C)	LG4	155	305	EC	Std.	2.29**

*S.A.E. net horsepower as installed. Std. — Standard. EC — Available at extra cost.
 **2.73 Performance Ratio available (RPO G92).

- (A) Produced by GM — Chevrolet Motor Division.
- (B) Produced by GM — Buick Motor Division.
- (C) Produced by GM — Chevrolet Motor Division and GM of Canada Engine Plants.

See EPA section for mileage estimates.

BODY/CHASSIS FEATURES

Standard On 1980 Monte Carlo

Body Structure & Features

- All-welded heavy-gage steel body construction with cowl, roof, underbody and body panels precision welded to form rigid body shell
- Rugged box-section design roof rails, windshield and rear window headers, door and roof pillars
- Heavy-gage steel roof panel with double-flanged channel-crossed reinforcing bows
- High-strength double-walled cowl unit-welded to instrument panel, floor, and dash panel
- Heavily ribbed and formed underbody with transverse stiffeners welded to underbody and body sills
- Double panel door, hood and deck lid
- Counterbalanced hood, deck lid for ease of operation
- Front and rear inner fenders for corrosion protection
- Flow-thru ventilation system for passenger comfort
- Cushioned body mounting system helps isolate passenger area from road noise and vibration
- Bolt-on front-end sheet metal cushion-mounted to frame and radiator support assembly for ease of service
- Concealed dual-speed electric windshield wipers
- Inside hood release for underhood security
- Acoustical quiet package
- Extensive anti-corrosion measures (see page 21)
- Durable acrylic finish

Chassis Features

- Power steering helps make parking and maneuvering in city

traffic easy

- Automatic transmission
- Power disc/rear drum brake system
- Disc brake audible wear sensors to let you know when linings need replacing
- Vented front disc brake rotors and finned rear brake drums aid heat dissipation
- Delcotron generator with built-in solid-state regulator
- Long recommended service intervals for oil change, oil filter, spark plugs, chassis lubrication and available automatic transmission fluid
- Visible ball joint wear indicators on front suspension lower control arms for quick and easy wear inspection
- Tire tread wear indicators
- Delco Freedom battery never needs refilling. Sealed side terminals help prevent corrosion buildup
- Full perimeter frame
- Full Coil suspension system with computer-selected springs
- Front and rear stabilizer bars to help control sway
- Forward-mounted recirculating ball steering gear and linkage
- Independent coil-spring spherical joint front suspension (short and long arm type) with quiet, low-friction non-metallic spherical joint liners and built-in anti-dive control
- Four-link-type rear suspension with dual bias-mounted upper control arms and parallel-mounted lower control arms
- Direct double-acting sealed-unit hydraulic shock absorbers
- Fully inflated, compact spare tire
- GM Specification P205/70R-14

steel-belted radial ply blackwall tires and 14" x 6" wheels

Body by Fisher Quality

1. Assembled car bodies, fenders, and hoods are chemically treated prior to painting to improve corrosion resistance.
2. Specially formulated corrosion-resistant primers and waxes are applied to areas that are especially vulnerable to corrosion.
3. The fenders and hoods are primed inside and out by either flow-coating, dipping, or electrodeposition, which is an immersion process in which the paint is electrically plated out on the parts. These processes insure coverage in all seams and crevices.
4. The bodies are primed either by the electrodeposition process or by a spray process using a corrosion-resistant flash primer. A primer-surfacer is then applied over the primer.
5. After baking, the primer-surfacer is wet sanded both with power sanders and hand sanders to help assure a smooth surface for the color topcoat.
6. The color topcoat is then applied to a specified film thickness and baked.
7. To block out road noise and provide additional corrosion resistance, an asphaltic base deadener is sprayed inside the wheelhousings at designated areas.
8. Paint repair, mars, nicks or scratches that occur during final assembly are corrected at the factory before shipment.

SOUND DEADENING FEATURES

- 1. Hood insulator — more dense than Malibu Classic (fiberglass blanket)
- 2. Amberlite® and molded Plastisol® dash mat with molded rubber seal around steering column
- 3. Amberlite® and mastic — shroud side insulator
- 4. Expandable plug — base of "A" pillar
- 5. ½" foam — headliner
- 6. Sealing strips and Amberlite® — roof side panel
- 7. Amberlite® and mastic — back seat barrier
- 8. Amberlite® and mastic — rear seat ledge sound barrier

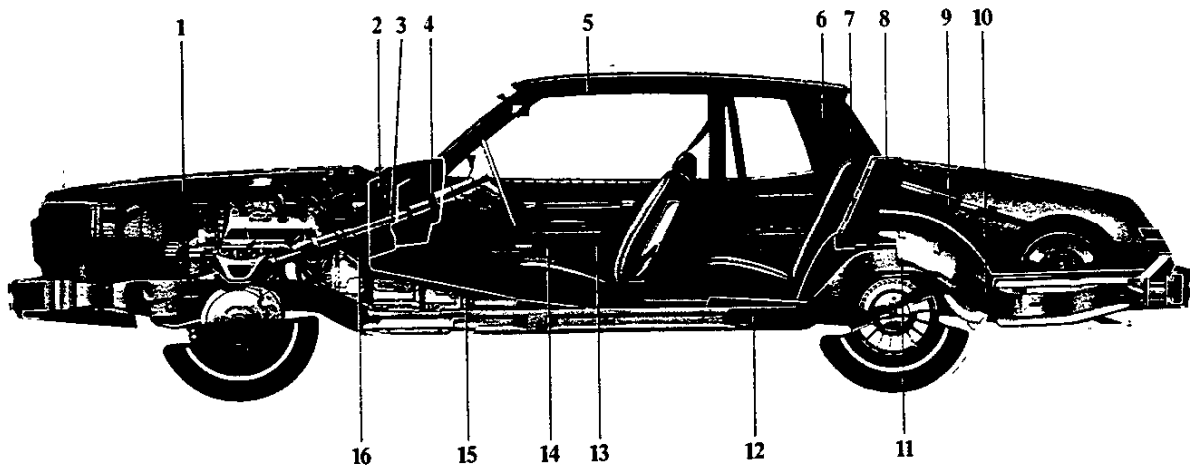

- 9. Amberlite® and mastic — upper quarter panel
- 10. Amberlite® — lower quarter panel
- 11. Spray-on sound deadener — rear wheelhousing
- 12. Amberlite® and mastic — underseat material
- 13. Amberlite® on inner doors
- 14. Spray-on sound deadeners on inner door panels
- 15. Double weight carpet backing and Amberlite® floor covering
- 16. Amberlite® and mastic — body shroud panel insulator

ANTI-CORROSION MEASURES

1. Precision molded polymer front and rear bumper outer surfaces
2. Precision molded polymer grille and headlight bezels
3. Precision molded polymer front end panel
4. Precision molded polymer front fender skirts, zinc-rich precoated metal process front fenders
5. Wax base spray on inner side of front fenders
6. Wax base spray on front fender rear reinforcement
7. Zinc spray on dash panel
8. Zinc-rich precoated metal

9. Precision molded polymer heater/air conditioning module
10. Phosphate oil-impregnated hood hinges
11. Zinc-rich precoated metal upper panel shroud
12. Zinc-rich precoated metal windshield glass support
13. Zinc spray on door hinge pillar
14. Rust preventative primer on door hinges
15. Zinc-rich precoated metal outside rearview mirror

16. Zinc-rich precoated metal outer door panel
17. Rust primer and wax spray on inner door panel
18. Zinc-rich precoated metal drip rail
19. Zinc chromate and wax spray on door upper frame at belt line
20. Plastisol® sealed door hem flanges
21. Primer on door opening facings
22. Plastisol® sealer on rear quarter panel to lock joint
23. Zinc-rich precoated metal outer wheelhousing panel

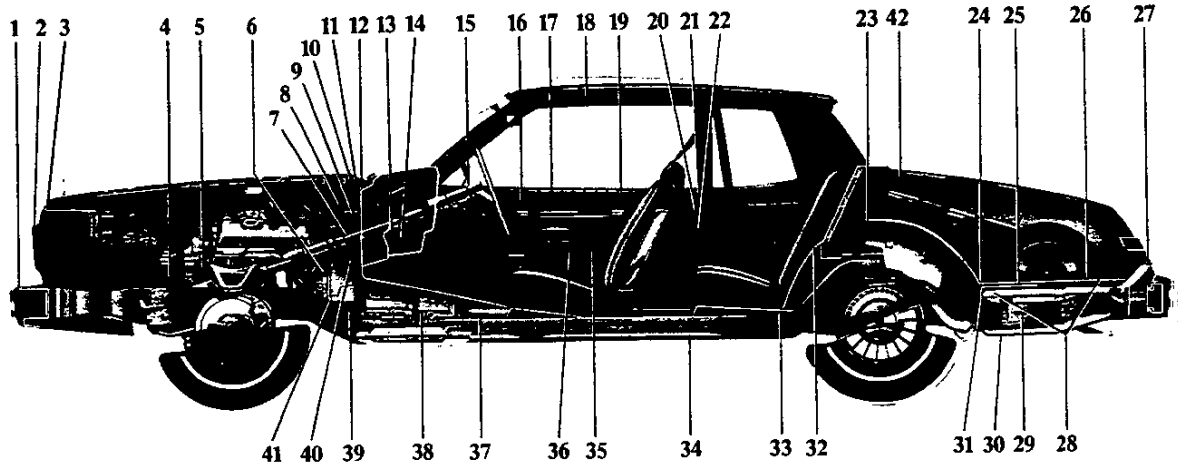

24. Electro precoated metal, with primer on rear quarter outer panel
25. Zinc-rich precoated metal gas tank rear compartment pan reinforcement
26. Zinc-rich precoated metal rear portion of rear compartment pan
27. Plastisol® sealer on inner and outer trunk lid hem flange
28. Zinc-rich precoated metal rear compartment pan reinforcements at body mount locations
29. Zinc-rich precoated metal

30. Abrasion-resistant exterior coating on lower portion of quarter panel
31. Primer and wax spray on quarter panel interior pockets
32. Hot melt sealer at quarter to wheelhousing joint
33. Zinc-rich precoated metal rear compartment pan to quarter panel filler
34. Zinc-rich precoated metal inner and outer sill panels
35. Zinc primer on lower door panel
36. Abrasion-resistant coating on lower portion of exterior

37. Prime coat on floor pan
38. Zinc prime coat on floor pan side extension
39. Zinc-rich precoated metal process to floor pan extension at toe plate
40. Zinc-rich precoated metal front fender to instrument panel plate
41. Zinc-rich precoated metal brace instrument panel to chassis
42. Aluminum with precoated metal support rear window to deck-lid panel

DIMENSIONS/ SPECIFICATIONS

EXTERIOR DIMENSIONS	<i>Coupe and Landau</i>
Wheelbase	108.1
Length (overall)	200.4
Width (overall)	71.5
Height (loaded)	53.9
Front tread	58.5
Rear tread	57.8
Minimum ground clearance	4.6
INTERIOR ROOMINESS	
Head room — front	37.6
Head room — rear	37.8
Leg room — front	42.8
Leg room — rear	36.3
Hip room — front	51.2
Hip room — rear	54.9
Shoulder room — front	56.3
Shoulder room — rear	55.9
LUGGAGE COMPARTMENT	
Liftover height	29.6
Usable luggage space (cu. ft.)	16.1
RATED FUEL TANK CAPACITY (gallons)	18.1
CURB WEIGHT (pounds)	
Monte Carlo Sport Coupe	3235

COLOR AND TRIM COMBINATIONS

INTERIOR COLORS

	BLACK	BLUE	CAMEL	CLARET	GREEN	OYSTER	OYSTER/ CAMEL*
MONTE CARLO SPECIAL CUSTOM INTERIOR							
Sport Coupe and Landau (55/45) Special Custom Cloth		X	X	X	X	X	
Special Custom Vinyl							X
MONTE CARLO							
Sport Coupe and Landau (Bench) Cloth	X	X	X	X			
Vinyl		X	X	X	X	X	
Sport Coupe and Landau (Bucket) Cloth	X	X	X	X			
Vinyl		X	X	X		X	

EXTERIOR COLORS	CODE	INT./EXT. COMB.	VINYL ROOF	INT./EXT. COMB.	VINYL ROOF	INT./EXT. COMB.	VINYL ROOF	INT./EXT. COMB.	VINYL ROOF	INT./EXT. COMB.	VINYL ROOF	INT./EXT. COMB.	VINYL ROOF
BEIGE	59	X	BB	X†		X	CC	X	RR	X†			
BLACK	19	X	BB	X	BB	X	BB†,CC	X	BB,RR	X	BB	X	QQ,BB
BLUE, DARK (METALLIC)	29	X	BB	X	DD,BB‡	X	CC				X	QQ	X†
BLUE, LIGHT (METALLIC)	21	X	BB,DD	X	DD,WW†						X	DD	
CAMEL, LIGHT (METALLIC)	63	X	CC			X	CC,WW†						X†
CAMEL, MEDIUM (METALLIC)	69	X	BB			X	CC						X†
CINNABAR	77	X	BB			X†					X	QQ	X†
CLARET (METALLIC)	75	X	BB					X	RR,WW†		X	QQ	
CLARET, DARK (METALLIC)	76	X	RR			X	CC,RR	X	RR,WW†		X	QQ,RR	X
GRAY	85	X	QQ	X	QQ	X	QQ	X	QQ,RR		X	QQ	X
GREEN, DARK (METALLIC)	44	X	GG			X	GG,CC			X	GG,WW†	X	GG
SILVER	15	X	BB	X				X	RR		X	BB	X†
WHITE	11	X	WW,BB	X	WW	X	WW,CC	X	WW,RR	X	WW	X	WW
YELLOW	50	X	BB			X†							

CUSTOM TWO-TONE (RPO D84) COLORS

BEIGE/CAMEL, LIGHT (METALLIC)					X	CC							
BLUE, DARK/BLUE, LIGHT (METALLICS)				X	DD						X	DD	
CAMEL, LIGHT (METALLIC)/BLACK	X	BB				X	BB					X	BB
CLARET/CLARET, DARK (METALLICS)						X	RR	X	RR		X	RR	X
GRAY/CLARET, DARK (METALLIC)								X	RR		X	RR	X
SILVER/BLACK	X	BB						X	BB		X	BB	X
WHITE/GRAY	X	QQ						X	QQ		X	QQ	X

*Oyster with Camel accents: Camel carpeting, cowl side panels, door pull strap facings, seat trim welts; Gray instrument panel and rear seat back ledge; Brown and Cream accent ribbons on seats, doors and rear quarter panels. †Not available on Landau. ‡WW — White also available except on Landau.

STANDARD INTERIOR TRIM GUIDE • Cloth seat trim and bench seat standard on all models. • All other combinations are available options, including Vinyl trim on bench seat, Vinyl trim on bucket seats or bucket seats with Cloth trim, and Special Custom Cloth trim with 55/45 seat.

1980 MONTE CARLO EXTERIOR COLORS

EXTERIOR COLORS

59 — Beige



19 — Black



29 — Blue, Dark (Metallic)



21 — Blue, Light (Metallic)



63 — Camel, Light (Metallic)

69 — Camel, Medium (Metallic)



77 — Cinnabar



75 — Claret (Metallic)

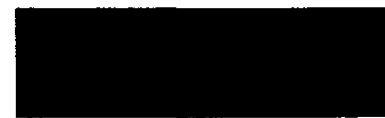

76 — Claret, Dark (Metallic)



85 — Gray

44 — Green, Dark (Metallic)



15 — Silver



11 — White



50 — Yellow



CUSTOM TWO-TONE PAINT (RPO D84)



Beige with Camel, Light (Metallic) accent color



White with Gray accent color

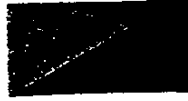

Gray with Claret, Dark (Metallic) accent color



Claret (Metallic) with Claret, Dark (Metallic) accent color



Blue, Dark (Metallic) with Blue, Light (Metallic) accent color



Camel, Light (Metallic) with Black accent color



Silver with Black accent color

VINYL ROOF COVERS

Landau Elk-grain (top). All others Levant-grain (bottom).



BB — Black



CC — Light Camel*

WW — White



DD — Light Blue*



GG — Dark Green*



QQ — Gray



RR — Dark Claret*

*Metallic

**It's a comfort to know
it's Body by Fisher**





1

2

3

4

5

6

7

8

9

10

11

12

13

14



✓ ALPHABETICAL OPTION INDEX

(Not for ordering purposes)

Option Number	Description	Option Number	Description
AG9	SEAT, POWER: Six-Way	N33	STEERING WHEEL: Comfortilt
AU3	DOOR LOCK SYSTEM, POWER	N95	WHEEL TRIM: Wheel Covers, Wire
A01	GLASS, TINTED: All Windows	QFK	TIRES: P205/70 R-14 Whitewall (Radial)
A31	WINDOWS, POWER	QFS	TIRES: P205/70 R-14 Blackwall (Radial)
A90	TRUNK OPENER, POWER	TR9	LIGHTING, AUXILIARY
BW2	MOLDINGS: Body Side, Deluxe	TT5	HI-INTENSITY, HI-BEAM HEADLAMPS
BX2	MOLDINGS: Bright Body Sill	UA1	BATTERY, HEAVY-DUTY
B3W	PRELIMINARY PRICE INFORMATION	UF7	GAGE PACKAGE
B37	FLOOR COVERING: Mats, Color-Keyed Floor. Front and Rear	UM2	RADIO EQUIPMENT: AM/FM Stereo Radio with 8-Track Stereo Tape
B48	LUGGAGE COMPARTMENT TRIM, DELUXE	UN3	RADIO EQUIPMENT: AM/FM Stereo Radio with Stereo Cassette Tape
B85	MOLDINGS: Side Window Sill	UP5	RADIO EQUIPMENT: AM/FM Citizens Band Radio with Power Antenna
B93	MOLDINGS: Door Edge Guard	UP6	RADIO EQUIPMENT: AM/FM Stereo/Citizens Band Radio with Power Antenna
CA1	SKY ROOF, POWER	UX6	RADIO EQUIPMENT: Speakers, Dual Front
CC1	ROOF PANELS: Removable Glass	U14	GAGE PACKAGE WITH TACHOMETER
CD4	WINDSHIELD WIPER SYSTEM: Intermittent	U58	RADIO EQUIPMENT: AM/FM Stereo Radio
C49	DEFOGGER, REAR WINDOW: Electric	U63	RADIO EQUIPMENT: AM Radio
C60	AIR CONDITIONING	U69	RADIO EQUIPMENT: AM/FM Radio
D24	CONTAINER, LITTER	U75	RADIO EQUIPMENT: Power Antenna
D33	MIRROR: Outside Rearview, LH Remote Control	U76	RADIO EQUIPMENT: Windshield Antenna
D34	MIRROR: RH Visor	U80	RADIO EQUIPMENT: Speaker, Rear Seat
D35	MIRRORS: Sport, LH Remote and RH Manual	U92	RADIO EQUIPMENT: Speakers, Dual Front and Dual Rear
D55	CONSOLE	V08	COOLING, HEAVY-DUTY
D60	NON-RECOMMENDED COLOR COMBINATION	YF5	EMISSION SYSTEM: California Emission Requirements
D64	MIRROR: RH Visor, Illuminated	ZJ7	WHEEL TRIM: Wheels, Rally
D68	MIRRORS: Sport, Twin Remote	ZX5	VALUE APPEARANCE PACKAGE - SPORT COUPE
D84	PAINT: Custom Two-Tone	✓ZY7	DOOR AND QUARTER TRIM PANELS, CUSTOM
D85	STRIPING, PIN: Body Side	ZY8	VALUE APPEARANCE PACKAGE - LANDAU
F40	SUSPENSION EQUIPMENT: Suspension, Heavy-Duty Front and Rear	Z03	LANDAU (Model Option)
G80	AXLE, REAR: Limited Slip Differential	Z06	INTERIOR, SPECIAL CUSTOM
G92	AXLE, REAR: Performance Ratio	19M	ACCENT: BLACK
K30	SPEED CONTROL: Automatic	21M	ACCENT: Light Blue Metallic
K73	GENERATOR: 70-Amp Delcotron	63M	ACCENT: Light Camel Metallic
LC3	ENGINE: 3.8 Liter 2 BBL V6	76M	ACCENT: Dark Claret Metallic
LC8	ENGINE: 3.8 Liter 4 BBL Turbocharged V6	85M	ACCENT: Gray
LD5	ENGINE: 3.8 Liter 2 BBL V6		
LG4	ENGINE: 5.0 Liter 4 BBL V8		
L39	ENGINE: 4.4 Liter 2 BBL V8		
NA5	EMISSION SYSTEM: Standard Emission Equipment		

MONTE CARLO LANDAU

COLOR AND TRIM SELECTION (Refer Page 6 for Additional Information)

PLEASE NOTE: The Exterior and Interior Combinations shown in the charts below and designated as recommended (R), represent the ideal combinations. Those that are shown as acceptable (A), are attractive, but less desirable than the recommended combinations.

Interior Trim Color	Black	Blue	Camel	Claret	Green	Oyster	Oyster/Camel
---------------------	-------	------	-------	--------	-------	--------	--------------

MODEL SEAT TYPE

WITH Z06 CUSTOM TRIM

1AZ37/	Special Custom Cloth 55:45	LDD3	LCC3	LRR3	LGG3	LWW3	
Z03	Special Custom Vinyl 55:45						XWW3

WITHOUT Z06 CUSTOM TRIM (Z06 MUST BE DELETED)

1AZ37/	Cloth Bench	CBB1	CDD1	CCC1	CRR1		
Z03	Cloth Bucket	CBB2	CDD2	CCC2	CRR2		
	Vinyl Bench		VDD1	VCC1	VRR1	VGG1	VWW1
	Vinyl Bucket		VDD2	VCC2	VRR2	VGG2	VWW2

WITH D84 CUSTOM TWO-TONE PAINT (ACCENT COLOR MUST BE SPECIFIED) (D60 NON-RECOMMENDED COLOR COMBINATION NOT PERMITTED)

Exterior Paint Color	Color Code L	Vinyl	Accent Color and Ordering Code#	Black	Blue	Camel	Claret	Green	Oyster	Oyster/Camel
Beige	59	CC	Lt Camel (Met) 63M			R				
Blue, Dark (Met)	29	DD	Lt Blue (Met) 21M		R				A	
Camel, Light (Met)	63	BB	Black 19M	R		R				R
Claret (Met)	75	RR	Dk Claret (Met) 76M			R	R		R	
Gray	85	RR	Dk Claret (Met) 76M				R		R	
Silver	15	BB	Black 19M	R			R		R	R
White	11	QQ	Gray 85M	R			R		R	R

*Must be Ordered

WITHOUT D84 CUSTOM TWO-TONE PAINT VINYL ROOF REQUIRED. SEE VINYL ROOF SELECTOR

PLEASE NOTE: Orders for additional Interior Trim combinations may be submitted, provided the dealer orders (D60), as verification that the requested combination is definitely desired.

Beige	59	R		R	R					
Black	19	R	R	R	R	R		R	R	R
Blue, Dark (Met)	29	A	R	R				A		
Blue, Light (Met)	21	A	R					A		
Camel, Light (Met)	63	A		R						R
Camel, Medium (Met)	69	R		R						
Cinnabar	77	R							R	
Claret (Met)	75	A				R		A		
Claret, Dark (Met)	76	A		R	R			R		
Gray	85	R	R	A	R			R	R	R
Green, Dark (Met)	44	A		R			R	A		
Silver	15	R				R		R		
White	11	R	R	R	R		R	R	R	R
Yellow	50	R								

VINYL ROOF SELECTOR

	L	U	U	U	U	U	U	U
Beige	59	BB		CC	RR			
Black	19	BB	BB	BB or CC	BB or RR	BB	BB or QQ	BB
Blue, Dark (Met)	29	BB	BB or DD	CC			QQ	
Blue, Light (Met)	21	BB or DD	DD				DD	
Camel, Light (Met)	63			CC				CC
Camel, Medium (Met)	69	BB		CC				
Cinnabar	77	BB					QQ	
Claret (Met)	75	BB			RR		QQ	
Claret, Dark (Met)	76	RR		RR or CC	RR		QQ or RR	
Gray	85	QQ	QQ	QQ	QQ or RR		QQ	QQ
Green, Dark (Met)	44	GG		CC or GG		GG	GG	
Silver	15	BB			RR		BB	
White	11	WW or BB	WW	WW or CC	WW or RR	WW	WW	WW
Yellow	50	BB						

L Lower U Upper

VINYL ROOF COLORS

WHITE WW LIGHT BLUE (MET) DD LIGHT CAMEL (MET) CC GRAY QQ
 BLACK BB DARK GREEN (MET) GG DARK CLARET (MET) RR

POWER TEAMS (Refer to next page for option availability and application)

ENGINE OPTION CONDITION	AXLE RATIO		
	2.29	2.41	2.73
WITH NA5 STANDARD EMISSIONS			
LC3	—	Std.	—
LC8	—	Std.	—
L39	Std.	—	—
LG4	Std.	—	G92
WITH YF5 CALIFORNIA EMISSIONS			
LD5	—	Std.	—
LC8	—	—	Std.
LG4	Std.	—	G92

MONTE CARLO LANDAU

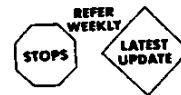

MODEL
 1A237/Z03 Monte Carlo Landau Coupe
 Z03 Landau (Reqs Vinyl Roof Cover)
 (Incls RH Visor Mirror and Specific Wheel Trim)

ENGINES: MUST ORDER ONE

AVAILABLE WITH NA5 STANDARD EMISSION EQUIPMENT

- LC3 3.8 Liter 2 BBL V6
- LC8 3.8 Liter 4 BBL Turbocharged V6
- LC9 4.4 Liter 2 BBL V8
- LG4 5.0 Liter 4 BBL V8

AVAILABLE WITH YF5 CALIFORNIA EMISSION REQUIREMENTS

- LC8 3.8 Liter 4 BBL Turbocharged V6
- LD5 3.8 Liter 2 BBL V6
- LG4 5.0 Liter 4 BBL V8

QUICK-SPEC

IF TIRE IN QUICK-SPEC IS NOT DESIRED YOU MUST "PLUS" ANOTHER TIRE OPTION.	4	4	4	4	4
Landau	Z03	x	x	x	x
Value Appearance Pkg	ZY8	x	x	x	x
Interior, Special Custom (Refer to Color and Trim Selection Chart for Custom Trim Ordering Codes)	Z06	x	x	x	x
Air Conditioning	C60	x	x	x	x
Console (w/ Bucket Seats)	D55	x	x	x	x
Glass, Tinted	A01	x	x	x	x
Mats, Color-Keyed Floor	B37	x	x	x	x
Moldings, Body Side Deluxe	BW2	x	x	x	x
Radio, AM	U63	x	N/I	N/I	N/I
Steering Wheel, Comfortilt	N33	x	x	x	x
Tires, P205/70 R-14 Whitewall	QFK	x	x	x	x
Lighting, Auxiliary	TR9	x	x	x	x
Moldings, Door Edge Guard	B93	x	x	x	x
Radio, AM/FM	U69	x	N/I	N/I	N/I
Speaker, Rear Seat	U80	x	N/I	N/I	N/I
Speed Control	K30	x	x	x	x
Windows, Power	A31	x	x	x	x
Defogger, Rear Window Electric	C49	x	x	x	x
Door Lock System, Power	AU3	x	x	x	x
Gage Package	UF7	x	x	x	x
Radio, AM/FM Stereo	U58	x	N/I	N/I	N/I
W/S Wiper System, Intermittent	CD4	x	x	x	x
Mirrors, Twin Remote Sport	D68	x	x	x	x
Power Antenna	U75	x	x	x	x
Radio, AM/FM Stereo w/8-Track Stereo Tape	UM2	x	x	x	x
Trunk Opener, Power	A90	x	x	x	x
Container, Litter	D24	x	x	x	x
Hi-Intensity, Hi-Beam Headlamps	TT5	x	x	x	x
Luggage Compartment Trim	B48	x	x	x	x
Mirror, Illuminated RH Visor	D64	x	x	x	x
Seat, Power (w/o Bucket Seats)	AG9	x	x	x	x

PLEASE REVIEW OPTION RESTRICTIONS BEFORE ORDERING

Q-S	OPTION
465	C60 AIR CONDITIONING AXLES, REAR: —Performance Ratio (See Power Teams Chart)
—	G92 —Limited Slip Differential (Incl Stowaway Spare Tire)
—	G80
—	UA1 BATTERY, HEAVY-DUTY
465	D55 CONSOLE: (Reqs Bucket Seats)
469	D24 CONTAINER, LITTER: (N/A YF5 Calif)
—	V08 COOLING, HEAVY-DUTY
467	C49 DEFOGGER, REAR WINDOW: Electric
467	AU3 DOOR LOCK SYSTEM, POWER EMISSION SYSTEMS: (Must Order Only One) (See Power Teams Chart)
—	YF5 —California Emission Requirements
—	NA5 —Standard Emission Equipment
465	B37 FLOOR COVERING: Mats, Color-Keyed Floor. Front and Rear

PLEASE REVIEW OPTION RESTRICTIONS BEFORE ORDERING

Q-S	OPTION
467	UF7 GAGE PACKAGE: (N/A U14 Gage Package)
—	U14 GAGE PACKAGE WITH TACHOMETER: (N/A UF7 Gages)
—	K73 GENERATOR: 70-Amp Delcotron (N/A C49 Defogger w/C60 Air) (N/A LC8 Eng)
465	A01 GLASS, TINTED: All Windows
469	TT5 HI-INTENSITY, HI-BEAM HEADLAMPS
465	Z06 INTERIOR, SPECIAL CUSTOM: (Refer Color and Trim Chart for Special Custom Trim Ordering Codes)
466	TR9 LIGHTING, AUXILIARY
469	B48 LUGGAGE COMPARTMENT TRIM, DELUXE MIRRORS: —Outside Rearview, LH Remote Control (N/A ZY8 Value App Pkg)
—	D33 —Sport, LH Remote and RH Manual (Incl w/ZY8 Value App Pkg)
—	D35 —Sport, LH Remote and RH Manual (Incl w/ZY8 Value App Pkg)
468	D68 —Sport, Twin Remote
469	D64 —RH Visor, Illuminated
465	BW2 MOLDINGS: —Body Side, Deluxe (See Page 6 for Color Application)
—	BX2 —Bright Body Sill (Incl w/ZY8 Value App Pkg)
—	B93 —Door Edge Guards
—	B85 —Side Window Sill (Incl w/ZY8 Value App Pkg)
—	D84 PAINT, CUSTOM TWO-TONE: (Refer Page 2 for Exterior Paint Availability and Page 6 for Add'l Information)
—	B3W PRELIMINARY PRICE INFORMATION
—	✓ RADIO EQUIPMENT: —AM Radio (w/LC8 Eng Reqs UX6 or U92 Speakers)
465	U63 —AM/FM Radio (w/LC8 Eng Reqs UX6 or U92 Speakers)
466	U69 —AM/FM Stereo Radio (w/LC8 Eng Reqs UX6 or U92 Speakers)
467	U58 —AM/FM Stereo Radio
468	UM2 —AM/FM Stereo Radio w/8-Track Stereo Tape
—	UN3 —AM/FM Stereo Radio w/Stereo Cassette Tape
—	UP5 —AM/FM/Citizens Band Radio w/Power Antenna (w/LC8 Eng Reqs UX6 or U92 Speakers) (w/o LC8 Eng Reqs U80 or U92 Speakers) (N/A with U75 Antenna)
—	UP6 —AM/FM Stereo/Citizens Band Radio w/Power Antenna (N/A U75 Antenna)
—	UX6 —Speakers, Dual Front (Reqs LC8 Eng and U63, U69 or UP5 Radio) (Incl w/U92 Speakers)
466	U80 —Speaker, Rear Seat (Reqs U63, U69 or UP5 Radio)
—	U92 —Speakers, Dual Front and Dual Rear (Reqs U63, U69 or UP5 Radio) (Incl w/U58, UM2, UN3, or UP6 Radio) (Incls UX6 Speakers)
—	U76 —Windshield Antenna (N/A UP5 or UP6 Radio) (Incl w/Above Radio Equip w/o U75 Antenna)
—	✓ 468 U75 —Power Antenna (Reqs U63, U69, U58, UM2 or UN3 Radio) (N/A U76 Antenna)
469	AG9 ROOF COVER, VINYL: (See Vinyl Roof Selector)
—	CA1 SEAT, POWER: Six-Way (N/A Bucket Seats) (Driver's Side Only w/55/45 Seat)
466	K30 SKY ROOF, POWER
465	N33 SPEED CONTROL: Automatic
—	D85 STEERING WHEEL: Comfortilt
—	F40 STRIPING PIN: Body Side (N/A D84 Paint) (Incl with ZY8 Value App Pkg w/o D84 Paint) (Refer to Page 6 for Stripe Color Application)
—	SUSPENSION EQUIPMENT: Suspension, Heavy-Duty Front and Rear
—	TIRES: (B/W: Blackwall, W/W: Whitewall) Steel Belted Radial Ply —P205/70 R-14 B/W (Base)
465	QFS —P205/70 R-14 W/W
468	QFK
465	A90 TRUNK OPENER, POWER
465	ZY8 VALUE APPEARANCE PACKAGE: (Incls BX2 and B85 Moldings, N95 Wire Wheels and D35 Sport Mirrors) (Also Incls D85 Striping w/o D84 Paint)
—	N95 WHEEL TRIM: Wheel Covers, Wire (Incl w/ZY8 Value App Pkg)
466	A31 WINDOWS: Power
467	CD4 WINDSHIELD WIPER SYSTEM: Intermittent

MONTE CARLO

COLOR AND TRIM SELECTION (Refer Page 6 for Additional Information)

PLEASE NOTE: The Exterior and Interior Combinations shown in the charts below and designated as recommended (R), represent the ideal combinations. Those that are shown as acceptable (A), are attractive, but less desirable than the recommended combinations.

Interior Trim Color		Black	Blue	Camel	Claret	Green	Oyster	Oyster/ Camel
MODEL	SEAT TYPE							
WITHOUT Z06 CUSTOM TRIM								
1AZ37	Cloth Bench	CBB1	CDD1	CCC1	CRR1			
	Cloth Bucket	CBB2	CDD2	CCC2	CRR2			
	Vinyl Bench		VDD1	VCC1	VRR1	VGG1	VWW1	
	Vinyl Bucket		VDD2	VCC2	VRR2	VGG2	VWW2	
WITH Z06 CUSTOM TRIM								
1AZ37	Special Custom Cloth 55/45		LDD3	LCC3	LRR3	LGG3	LWW3	XWW3
	Special Custom Vinyl 55/45							

WITH D84 CUSTOM TWO-TONE PAINT (ACCENT COLOR MUST BE SPECIFIED) (D60 NON-RECOMMENDED COLOR COMBINATION NOT PERMITTED)

Exterior Paint Color	Color Code L	Color Code U	Accent Color and Ordering Code#	Black	Blue	Camel	Claret	Green	Oyster	Oyster/ Camel
Beige	59	59	Lt Camel (Met) 63M			R				
Blue, Dark (Met)	29	29	Lt Blue (Met) 21M		R				A	
Camel, Light (Met)	63	63	Black 19M	R						R
Claret (Met)	75	75	Dk Claret (Met) 76M			R	R		R	
Gray	85	85	Dk Claret (Met) 76M				R		R	
Silver	15	15	Black 19M	R			R		R	R
White	11	11	Gray 85M	R			R		R	R

*Must be Ordered

WITHOUT D84 CUSTOM TWO-TONE PAINT

PLEASE NOTE: Orders for additional Interior Trim combinations may be submitted, provided the dealer orders (D60), as verification that the requested combination is definitely desired.

Beige	59	59		R		R	R	R	A		
Black	19	19		R		R	R	R	R		R
Blue, Dark (Met)	29	29		A		R	R			A	
Blue, Light (Met)	21	21		A		R				A	
Camel, Light (Met)	63	63		A		R					R
Camel, Medium (Met)	69	69		R		R				A	R
Cinnabar	77	77		R		R				R	R
Claret (Met)	75	75		A			R			A	
Claret, Dark (Met)	76	76		A		R	R			R	
Gray	85	85		R		A	R			R	R
Green, Dark (Met)	44	44		A		R		R		A	
Silver	15	15		R		R		R		R	R
White	11	11		R		R	R		R	R	R
Yellow	50	50		R		R				A	

VINYL ROOF SELECTOR

	L	U	U	U	U	U	U	U
Beige	59	BB		CC	RR			
Black	19	BB		BB or CC	BB or RR	BB	BB or QQ	BB
Blue, Dark (Met)	29	BB	WW or DD	CC			QQ	
Blue, Light (Met)	21	BB or DD	WW or DD				DD	
Camel, Light (Met)	63	CC		WW or CC				CC
Camel, Medium (Met)	69	BB		CC				
Cinnabar	77	BB					QQ	
Claret (Met)	75	BB			WW or RR		QQ	
Claret, Dark (Met)	76	RR		RR or CC	WW or RR		QQ or RR	
Gray	85	QQ	QQ	QQ	QQ or RR		QQ	QQ
Green, Dark (Met)	44	GG		CC or GG		WW or GG	GG	
Silver	15	BB			RR		BB	
White	11	WW or BB	WW	WW or CC	WW or RR	WW	WW	WW
Yellow	50	BB						

L - Lower U - Upper

VINYL ROOF COLORS

WHITE WW LIGHT BLUE (MET) DD LIGHT CAMEL (MET) CC GRAY QQ
 BLACK BB DARK GREEN (MET) GG DARK CLARET (MET) ... RR

POWER TEAMS (Refer to next page for option availability and application)

ENGINE OPTION CONDITION	AXLE RATIO		
	2.29	2.41	2.73
WITH NA5 STANDARD EMISSIONS			
LC3	—	Std.	—
LC8	—	Std.	—
L39	Std.	—	—
LG4	Std.	—	G92
WITH YF5 CALIFORNIA EMISSIONS			
LD5	—	Std.	—
LC8	—	—	Std.
LG4	Std.	—	G92

MONTE CARLO

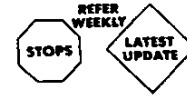

MODEL
1A237 Monte Carlo Sport Coupe
ENGINES: MUST ORDER ONE

AVAILABLE WITH NA5 STANDARD EMISSION EQUIPMENT
 _____ LC3 3.8 Liter 2 BBL V6
 _____ LC8 3.8 Liter 4 BBL Turbocharged V6
 _____ L39 4.4 Liter 2 BBL V8
 _____ LG4 5.0 Liter 4 BBL V8

AVAILABLE WITH YF5 CALIFORNIA EMISSION REQUIREMENTS
 _____ LC8 3.8 Liter 4 BBL Turbocharged V6
 _____ LD5 3.8 Liter 2 BBL V6
 _____ LG4 5.0 Liter 4 BBL V8

QUICK-SPEC

IF TIRE IN QUICK-SPEC IS NOT NOT DESIRED YOU MUST *PLUS* ANOTHER TIRE OPTION.

✓	✓	✓	✓	✓
4	4	4	4	4
6	6	6	6	6
0	1	2	3	4
B	B	B	B	B

Value Appearance Pkg	ZX5	x	x	x	x	x
Door and Quarter Trim Panels, Cust	ZY7	x	x	x	x	x
Air Conditioning	C60	x	x	x	x	x
Console (w/ Bucket Seats Only)	D55	x	x	x	x	x
Glass, Tinted	A01	x	x	x	x	x
Moldings, Body Side Deluxe	BW2	x	x	x	x	x
Radio, AM	U63	x	x	N/1	N/1	N/1
Tires, P205/70 R-14 Whitewall	QFK	x	x	x	x	x
Mats, Color-Keyed Floor	B37	x	x	x	x	x
Moldings, Door Edge Guard	B93	x	x	x	x	x
Lighting, Auxiliary	TR9	x	x	x	x	x
Speed Control	K30	x	x	x	x	x
Steering Wheel, Comfortilt	N33	x	x	x	x	x
Defogger, Rear Window Electric	C49	x	x	x	x	x
Door Lock System, Power	AU3	x	x	x	x	x
Radio, AM/FM	U69	x	x	N/1	N/1	N/1
Speaker, Rear Seat	U80	x	x	N/1	N/1	N/1
Windows, Power	A31	x	x	x	x	x
Gage Package	UF7	x	x	x	x	x
Radio, AM/FM Stereo	U58	x	x	N/1	N/1	N/1
Wheel Covers, Wire	N95	x	x	x	x	x
W/S Wiper System, Intermittent	CD4	x	x	x	x	x
Container, Litter	D24	x	x	x	x	x
Power Antenna	U75	x	x	x	x	x
Radio, AM/FM Stereo w/8-Track Stereo Tape	UM2	x	x	x	x	x
Seat, Power (w/o Bucket Seats)	AG9	x	x	x	x	x
Trunk Opener, Power	A90	x	x	x	x	x

PLEASE REVIEW OPTION RESTRICTIONS BEFORE ORDERING

QS	OPTION	DESCRIPTION
460	C60	AIR CONDITIONING
_____	G92	AXLES, REAR: Performance Ratio (See Power Teams Chart)
_____	G80	Limited Slip Differential (Includes Stowaway Spare Tire)
_____	UA1	BATTERY, HEAVY-DUTY
460	D55	CONSOLE: (Reqs Bucket Seats)
464	D24	CONTAINER, LITTER: (N/A YF5 Calif)
_____	V08	COOLING, HEAVY-DUTY
462	C49	DEFOGGER, REAR WINDOW: Electric
✓ 460	ZY7	DOOR AND QUARTER TRIM PANELS, CUSTOM: (N/A Z06 Custom Interior)
462	AU3	DOOR LOCK SYSTEM, POWER
_____	YF5	EMISSION SYSTEMS: (Must Order Only One) (See Power Teams Chart)
_____	NA5	California Emission Requirements
461	B37	Standard Emission Equipment
463	UF7	FLOOR COVERING: Mats, Color-Keyed Floor. Front and Rear
_____	U14	GAGE PACKAGE: (N/A U14 Gage Package)
_____	U14	GAGE PACKAGE WITH TACHOMETER: (N/A UF7 Gages)
_____	K73	GENERATOR: 70-Amp Delcotron (N/A C49 Defogger w/C60 Air) (N/A LC8 Eng)

PLEASE REVIEW OPTION RESTRICTIONS BEFORE ORDERING

QS	OPTION	DESCRIPTION
460	A01	GLASS, TINTED: All Windows
_____	TT5	HI-INTENSITY, HI-BEAM HEADLAMPS
✓ _____	Z06	INTERIOR, SPECIAL CUSTOM: (Refer to Color and Trim Chart for Special Custom Trim Ordering Codes) (N/A ZY7 Custom Trim Panels)
461	TR9	LIGHTING, AUXILIARY
_____	B48	LUGGAGE COMPARTMENT TRIM, DELUXE
_____	D33	MIRRORS: Outside Rearview, LH Remote Control (N/A ZX5 Value App Pkg)
_____	D35	Sport, LH Remote and RH Manual (Incl w/ZX5 Value App Pkg)
_____	D68	Sport, Twin Remote
_____	D34	RH Visor
_____	D64	RH Visor, Illuminated
460	BW2	MOLDINGS: Body Side, Deluxe. (See Page 6 for Color Application)
_____	BX2	Bright Body Sill (Incl w/ZX5 Value App Pkg)
461	B93	Door Edge Guards
_____	B85	Side Window Sill (Incl w/ZX5 Value App Pkg)
_____	D84	PAINT, CUSTOM TWO-TONE: (N/A Vinyl Roof Cover) (Refer Page 4 Exterior Paint Availability and Page 6 for Add'l Information)
_____	B3W	PRELIMINARY PRICE INFORMATION
✓ _____	U63	RADIO EQUIPMENT: AM Radio (w/LC8 Eng Reqs UX6 or U92 Speakers)
462	U69	AM/FM Radio (w/LC8 Eng Reqs UX6 or U92 Speakers)
463	U58	AM/FM Stereo Radio
464	UM2	AM/FM Stereo Radio w/8-Track Stereo Tape
_____	UN3	AM/FM Stereo Radio w/Stereo Cassette Tape
_____	UP5	AM/FM/Citizens Band Radio w/Power Antenna (w/LC8 Eng Reqs UX6 or U92 Speakers) (w/o LC8 Eng Reqs U80 or U92 Speakers) (N/A U75 Antenna)
_____	UP6	AM/FM Stereo/Citizens Band Radio w/Power Antenna (N/A U75 Antenna)
_____	UX6	Speakers, Dual Front (Reqs LC8 Eng and U63, U69 or UP5 Radio) (Incl w/U92 Speakers)
462	U80	Speaker, Rear Seat (Reqs U63, U69 or UP5 Radio)
✓ _____	U92	Speakers, Dual Front and Dual Rear (Reqs U63, U69 or UP5 Radio) (Incl w/U58, UM2, UN3 or UP6 Radio) (Incls UX6 Speakers)
_____	U76	Windshield Antenna (N/A UP5 or UP6 Radio) (Incl w/Above Radio Equip w/o U75 Antenna)
✓ 464	U75	Power Antenna (Reqs U63, U69, U58, UM2 or UN3 Radio) (N/A U76 Antenna)
_____	CC1	ROOF COVER, VINYL: (N/A D84 Paint) (See Vinyl Roof Selector)
_____	CC1	ROOF PANELS: Removable Glass (N/A CA1 Sky Roof or Vinyl Roof Cover)
464	AG9	SEAT, POWER: Six-Way (N/A Bucket Seats) (Driver's side only w/55/45 Seat)
_____	CA1	SKY ROOF, POWER
461	K30	SPEED CONTROL: Automatic
461	N33	STEERING WHEEL: Comfortilt
_____	D85	STRIPING, PIN: Body Side (N/A D84 Paint) (Incl with ZX5 Value App Pkg w/o D84 Paint) (Refer to Page 6 for Stripe Color Application)
_____	F40	SUSPENSION EQUIPMENT: Suspension, Heavy-Duty Front and Rear
_____	QFS	TIRES: (B/W: Blackwall, W/W: Whitewall)
460	QFK	Steel Belted Radial Ply
464	A90	P205/70 R-14 B/W (Base)
460	ZX5	P205/70 R-14 W/W
_____	A90	TRUNK OPENER, POWER
460	ZX5	VALUE APPEARANCE PACKAGE: (Incls BX2 and B85 Moldings, ZJ7 Rally Wheels and D35 Sport Mirrors) (Also Incls D85 Striping w/o D84 Paint)
463	N95	WHEEL TRIM: Wheel Covers, Wire
_____	ZJ7	Wheels, Rally (Incl w/ZX5 Value App Pkg)
462	A31	WINDOWS: Power
463	CD4	WINDSHIELD WIPER SYSTEM: Intermittent

MONTE CARLO

WITHOUT D84 CUSTOM TWO-TONE PAINT

STRIPE COLOR ONLY WHEN D85 STRIPE, ZX5 OR ZY8 APPEARANCE PACKAGES ARE ORDERED.
MOLDING COLOR ONLY WHEN BW2 MOLDING IS ORDERED
VINYL ROOF — ONLY WHEN APPROPRIATE ORDERING CODE IS INDICATED

EXTERIOR PAINT COLOR	INTERIOR TRIM COLOR						
	BLACK	BLUE	CAMEL	CLARET	GREEN	OYSTER	OYSTER/ CAMEL
BEIGE 59 Stripe Molding Vinyl Roof	R BROWN LT CAMEL(MET) BLACK	R BROWN LT CAMEL(MET) N/A	R BROWN LT CAMEL(MET) CAMEL	R CLARET CAMEL(MET) CLARET	A BROWN LT CAMEL(MET) N/A	GOLD LT CAMEL(MET) N/A	BROWN LT CAMEL N/A
BLACK 19 Stripe Molding Vinyl Roof	R GOLD BLACK BLACK	R BLUE BLACK BLACK	R GOLD BLACK BLACK/CAMEL	R RED BLACK BLACK/CLARET	R GOLD BLACK BLACK	R SILVER BLACK BLACK/GRAY	R SILVER BLACK BLACK
BLUE, DARK(MET) 29 Stripe Molding Vinyl Roof	A SILVER BLACK BLACK	R #BLUE #BLACK BLUE/WHITE	R GOLD BLACK CAMEL	CLARET BLACK N/A	SILVER BLACK N/A	A SILVER BLACK GRAY	SILVER BLACK N/A
BLUE, LIGHT(MET) 21 Stripe Molding Vinyl Roof	A SILVER LT BLUE(MET) BLACK/BLACK	R #SILVER #LT BLUE(MET) BLUE/WHITE	SILVER LT BLUE(MET) BLUE	SILVER LT BLUE(MET) BLUE	SILVER LT BLUE(MET) BLUE	A SILVER LT BLUE(MET) BLUE	SILVER BLUE BLUE
CAMEL, LIGHT(MET) 63 Stripe Molding Vinyl Roof	A BROWN LT CAMEL(MET) CAMEL	BLACK LT CAMEL(MET) CAMEL	R #BROWN #LT CAMEL(MET) CAMEL/WHITE	CLARET LT CAMEL(MET) CAMEL	BLACK LT CAMEL(MET) CAMEL	BROWN LT CAMEL(MET) CAMEL	BROWN LT CAMEL CAMEL
CAMEL, MED(MET) 69 Stripe Molding Vinyl Roof	R GOLD LT CAMEL(MET) BLACK	GOLD LT CAMEL(MET) N/A	R BROWN LT CAMEL(MET) CAMEL	GOLD LT CAMEL(MET) N/A	GOLD LT CAMEL(MET) N/A	A GOLD LT CAMEL(MET) N/A	A GOLD CAMEL N/A
CINNABAR 77 Stripe Molding Vinyl Roof	R BLACK BLACK BLACK	BLACK BLACK N/A	R GOLD GRAY N/A	BLACK BLACK N/A	BLACK BLACK N/A	R WHITE GRAY GRAY	R GOLD BLACK N/A
CLARET(MET) 75 Stripe Molding Vinyl Roof	A GOLD DK CLARET(MET) BLACK	SILVER DK CLARET(MET) N/A	GOLD DK CLARET(MET) N/A	R #GOLD #DK CLARET(MET) CLARET/WHITE	GOLD DK CLARET(MET) N/A	A SILVER DK CLARET(MET) GRAY	SILVER CLARET N/A
CLARET, DARK(MET) 76 Stripe Molding Vinyl Roof	A GOLD DK CLARET(MET) CLARET	SILVER DK CLARET(MET) CLARET	R GOLD DK CLARET(MET) CLARET/CAMEL	R #GOLD #DK CLARET(MET) CLARET/WHITE	GOLD DK CLARET(MET) CLARET	R SILVER DK CLARET(MET) GRAY/CLARET	GOLD CLARET CLARET
GRAY 85 Stripe Molding Vinyl Roof	R BLACK GRAY GRAY	R BLUE GRAY GRAY	A BROWN GRAY GRAY	R CLARET GRAY GRAY/CLARET	BLACK GRAY N/A	R WHITE GRAY GRAY	R BROWN GRAY GRAY
GREEN, DARK(MET) 44 Stripe Molding Vinyl Roof	A GOLD BLACK GREEN	SILVER BLACK GREEN	R GOLD BLACK CAMEL/GREEN	SILVER BLACK GREEN	R #GOLD #BLACK GREEN/WHITE	A SILVER BLACK GREEN	GOLD BLACK GREEN
SILVER 15 Stripe Molding Vinyl Roof	R BLACK GRAY BLACK	R BLUE GRAY N/A	BLACK GRAY N/A	R CLARET GRAY CLARET	BLACK GRAY N/A	R RED GRAY BLACK	R BLACK GRAY N/A
WHITE 11 Stripe Molding Vinyl Roof	R BLACK WHITE WHITE/BLACK	R BLUE WHITE WHITE	R GOLD WHITE WHITE/CAMEL	R CLARET WHITE WHITE/CLARET	R GOLD WHITE WHITE	R RED WHITE WHITE	R GOLD WHITE WHITE
YELLOW 50 Stripe Molding Vinyl Roof	R BLACK BLACK BLACK	BLACK BLACK N/A	R BROWN GRAY N/A	BLACK BLACK N/A	BLACK BLACK N/A	A WHITE WHITE N/A	BROWN GRAY N/A

R = Recommended Combinations
A = Acceptable Combinations
• = WW Vinyl Roof N/A Z03 Landau

SHADED AREA = Non-Recommended Combination
(Reqs. D60 Non-Recommended Color Combination Option)
= With White Roof Cover, Stripes and Moldings will be White

WITH D84 CUSTOM TWO-TONE PAINT (NO SUBSTITUTES ALLOWED)

STRIPE COLOR — INCLUDED
MOLDING COLOR — ONLY WHEN BW2 MOLDING IS ORDERED
VINYL ROOF — ONLY WHEN APPROPRIATE ORDERING CODE IS INDICATED

Exterior Paint Color	Color Code		Accent Color and Ordering Code		Stripe (Included)	Molding BW2	
	L	U or Vinyl					
Beige	59	59	CC	Lt Camel (Met)	63M	Gold/Brown	Camel
Blue, Dark (Met)	29	29	DD	Lt Blue (Met)	21M	Silver/Blue	Black
Camel, Light (Met)	63	63	BB	Black	19M	Gold/Brown	Camel
Claret (Met)	75	75	RR	Dk Claret (Met)	76M	Gold/Black	Claret
Gray	85	85	RR	Dk Claret (Met)	76M	Claret/Silver	Gray
Silver	15	15	BB	Black	19M	Red/Black	Gray
White	11	11	QQ	Gray	85M	Claret/Silver	White

L = Lower U = Upper *With Z03 Landau Only.

MONTE CARLO

1980 VEHICLES WITH STANDARD EQUIPMENT

Prices shown are effective with vehicles produced on and after July 1, 1980

Description	Model Number	Body Code	Wheel Base	Dealer Invoice Amount*	Dealer Price	Factory D&H(a)	List Price	Mfr's Sg'd Retail Price*	Group Number
◆ 6-Cylinder Engine									
Sport Coupe	1A237	—	108.1"					6683.69	5
Landau Coupe	1A237 /Z03		108.1"					6954.69	5

- ★ Manufacturer's Suggested Retail Prices do not include applicable destination charges, state and local taxes, license fees, optional equipment or accessories or special items or services.
 ◆ Refer to Dealer Order Guide for California Requirements.

OPTIONS AND ACCESSORIES WHEN INSTALLED BY CHEVROLET

Prices shown are effective with vehicles produced on and after July 1, 1980

Description	Option Number	Dealer Invoice Amount*	Dealer Price	Factory D&H(a)	List Price	Mfr's Suggested Retail Price◇
REFER TO DEALER ORDER GUIDE FOR OPTION AVAILABILITY AND APPLICATION						
Interior Trim:						
C**1 Cloth Bench Seat					NO ADDITIONAL CHARGE	
C**2 Cloth Bucket Seats						91.00
V**1 Vinyl Bench Seat						28.00
V**2 Vinyl Bucket Seats						91.00
<i>Special Custom. Includes 55 /45 seat with folding center armrest, custom door trim panels and seats.</i>						
With L**3 Special Custom Cloth	Z06					366.00
With X**3 Special Custom Vinyl	Z06					394.00
Exterior Color:						
Paint, Solid					NO ADDITIONAL CHARGE	
<i>Custom Two-Tone. Includes upper body accent, color-keyed striping.</i>						
Without ZY8 or ZX5 Value Appearance Group	D84					171.00
With ZY8 or ZX5 Value Appearance Group	D84					148.00
Roof Cover, Vinyl. Standard on Z03 Landau						140.00
Engines: (Refer to Dealer Order Guide for Emission System Requirements)						
3.8 Liter 2 BBL V6	LC3				NO ADDITIONAL CHARGE	
3.8 Liter 2 BBL V6	LD5				NO ADDITIONAL CHARGE	
3.8 Liter 4 BBL Turbocharged V6	LC8					650.00
4.4 Liter 2 BBL V8	L39					80.00
5.0 Liter 4 BBL V8	LG4					80.00
Air Conditioning: Four-Season. Includes increased cooling	C60					601.00
Axles, Rear:						
Performance Ratio	G92					19.00
Limited Slip Differential. Includes Stowaway Spare Tire	G80					68.51
Battery, Heavy-Duty	UA1					21.00
Console: Shift lever mounted on console	D55					86.00
Container, Litter: Color-Keyed	D24					8.50
Cooling, Heavy-Duty						
Without C60 Air Conditioning	V08					63.00
With C60 Air Conditioning	V08					36.00
Custom Door and Quarter Trim Panels	ZY7					27.00
Defogger, Rear Window: Electric	C49					107.00
Door Lock System, Power: Electric	AU3					93.00
Emission Systems:						
<i>California Emission Requirements. Includes all testing, equipment and /or certification necessary for registration in the State of California</i>						
Standard Emission System	YF5					250.00
	NA5				NO ADDITIONAL CHARGE	
Floor Covering: 2 front and 2 rear color-keyed floor mats	B37					25.00
Gage Package: includes temperature, voltmeter and oil pressure gages	UF7					41.00

- * Dealer Invoice Amount includes 2% Holdback Amount retained for dealer's account. To obtain Dealer Invoice Amount with 3% Holdback Plan, add 1% of list price to Dealer Invoice Amount on each item.
 (a) D & H Charges on vehicle and optional equipment include reimbursement to Chevrolet Motor Division for any tax that it has paid, incurred or agreed to pay thereon.
 ◇ State and local taxes not included.

MONTE CARLO

OPTIONS AND ACCESSORIES WHEN INSTALLED BY CHEVROLET

Prices shown are effective with vehicles produced on and after July 1, 1980

Description	Option Number	Dealer Invoice Amount*	Dealer Price	Factory D&H(a)	List Price	Mfr's Suggested Retail Price◇
REFER TO DEALER ORDER GUIDE FOR OPTION AVAILABILITY AND APPLICATION						
Gage Package with Tachometer: Includes tachometer and voltmeter, temperature and oil pressure gages.	U14					109.00
Generator, 70-Amp Delcotron:						
Without C60 Air Conditioning and C49 Rear Window Defogger.....	K73					67.00
With C60 Air Conditioning or C49 Rear Window Defogger.....	K73					32.00
Glass, Tinted: All Windows	A01					75.00
Headlamps, Hi-Intensity Hi-Beam	TT5					26.00
Lighting, Auxiliary: Includes luggage compartment and underhood lights, dome delay switch plus headlamp warning buzzer.....	TR9					33.00
Luggage Compartment Trim, Deluxe: Includes black cut pile floor carpeting and carpeted spare tire cover.	B48					46.00
Mirrors:						
<i>Outside Rearview, LH Remote</i>	D33					19.00
<i>Sport, Body-Colored LH Remote and RH Manual. Included with ZY8 or ZX5 Value Appearance Package</i>	D35					46.00
<i>Sport, Twin Remote</i>						
Without ZY8 or ZX5 Value Appearance Package.....	D68					73.00
With ZY8 or ZX5 Value Appearance Package.....	D68					48.00
<i>Visor Vanity, Standard on Z03 Landau</i>	D34					6.00
<i>Visor Vanity, Illuminated</i>						
Without Z03 Landau.....	D64					43.00
With Z03 Landau.....	D64					37.00
Moldings:						
<i>Body Side, Deluxe.</i> Includes color-keyed vinyl insert.....	BW2					57.00
<i>Bright Body Sill.</i> Included with ZY8 or ZX5 Value Appearance Package.....	BX2					47.00
<i>Door Edge Guard</i>	B93					14.00
<i>Side Window Sill</i> Included with ZY8 or ZX5 Value Appearance Package.....	B85					35.00
Radio Equipment:						
<i>AM Radio</i>	U63					97.00
<i>AM /FM Radio</i>	U69					153.00
<i>AM /FM Stereo Radio</i>	U58					182.00
<i>AM Radio with 8 Track Stereo Tape</i>	UM1					249.00
<i>AM /FM Stereo Radio with 8 Track Stereo Tape</i>	UM2					272.00
<i>AM /FM Stereo Radio with Stereo Cassette Tape</i>	UN3					285.00
<i>AM /FM /Citizens Band Radio and Power Antenna</i>	UP5					473.00
<i>AM /FM Stereo /Citizens Band Radio and Power Antenna</i> ..	UP6					525.00
<i>Speaker, Rear Seat</i>	U80					20.00
<i>Speakers, Dual Front.</i> Included with U92 Dual Front and Dual Rear Speakers.....	UX6					14.00
<i>Speakers, Dual Front and Dual Rear.</i> Included with U58, UM1, UM2, UN3, or UP6 Radio. Also includes UX6 Dual Front Speakers.....	U92					43.00
<i>Windshield Antenna.</i> Included with radio.....	U76					27.00
<i>Power Antenna</i>	U75					51.00
Roof Panels: Removable Glass	CC1					695.00
Seat, Power: Electric, 6-Way Control. Front seat. Driver's side with 55 /45 Seat.....	AG9					175.00
Sky Roof, Power Sliding metal top.....	CA1					561.00
Speed Control: Automatic	K30					112.00
Steering Wheel: Comfortilt	N33					81.00
Striping, Pin: Body Side. Included with ZY8 or ZX5 Value Appearance Package without D84 Custom Two-Tone Paint..	D85					42.00
Suspension Equipment: Suspension, Heavy-Duty Front and Rear. Includes special front and rear springs and matching shock absorbers.....	F40					24.00
Tires:						
<i>P205 /70 R-14 Steel Belted Radial Ply Blackwall (Standard)</i>	QFS				NO ADDITIONAL CHARGE	
<i>P205 /70 R-14 Steel Belted Radial Ply White Stripe</i>	QFK					51.00

* Dealer Invoice Amount includes 2% Holdback Amount retained for dealer's account. To obtain Dealer Invoice Amount with 3% Holdback Plan, add 1% of list price to Dealer Invoice Amount on each item.

(a) D & H Charges on vehicle and optional equipment include reimbursement to Chevrolet Motor Division for any tax that it has paid, incurred or agreed to pay thereon.

◇ State and local taxes not included.



Vertical line of text on the right side of the page, possibly a page number or margin indicator.



GENERAL

MONTE CARLO LANDAU
(1AZ37 Model with RPO Z03)

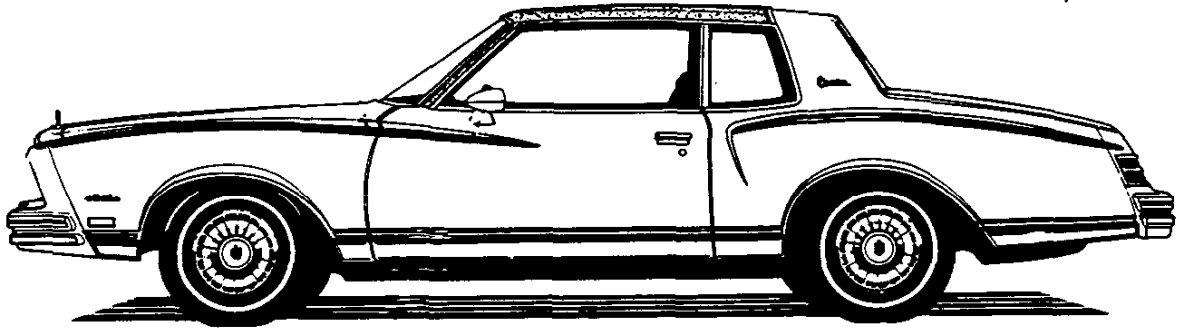

MODEL IDENTIFICATION	2
SERIAL NUMBERS AND IDENTIFICATION	3
EXTERIOR EQUIPMENT	4
INTERIOR EQUIPMENT	5-6
EXTRA COST EQUIPMENT	7-9
"LANDAU" OPTION EQUIPMENT RPO Z03	10
LUXURY INTERIOR OPTION RPO Z06	10
"SUN ROOF" (TWIN HATCH TYPE) RPO CC1	11
AIR CONDITIONING EQUIPMENT RPO C60	12

MODEL IDENTIFICATION

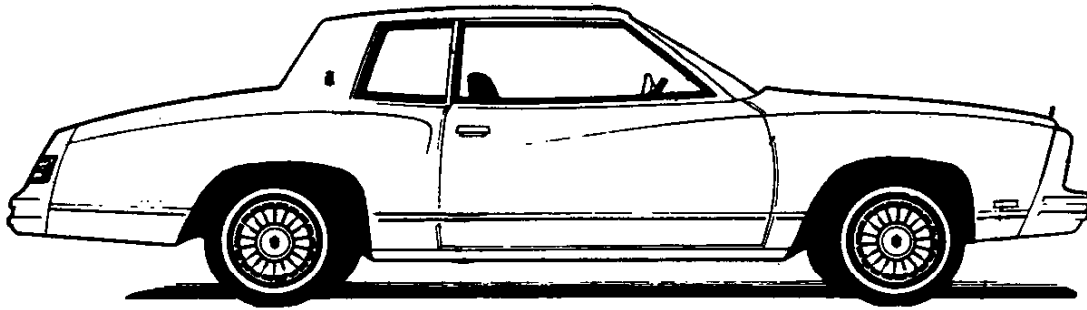

BODY	SERIES NAME	BODY STYLE	MODEL DESIGNATION	PASS OR SEATS
A-SPECIAL	MONTE CARLO	2-Dr. Sport Coupe	1AZ.37	6

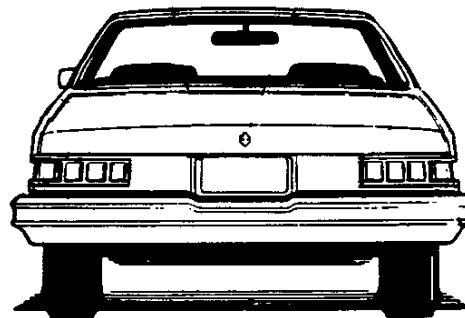
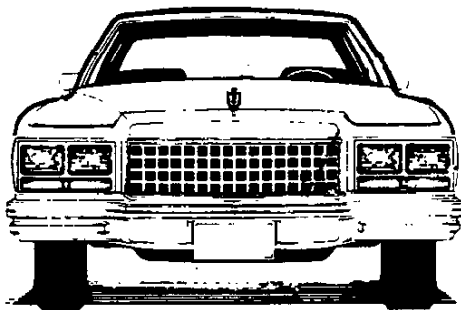

SERIAL NUMBERS AND IDENTIFICATION

ONLY BASIC DESIGNATIONS SHOWN

VEHICLE IDENTIFICATION NUMBER

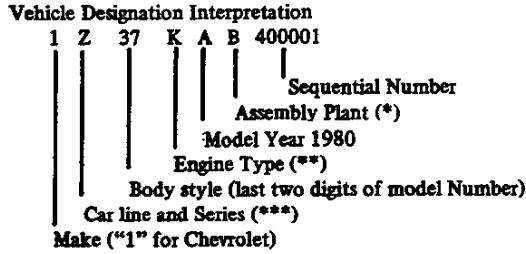

*B - Baltimore-GMAD	R - Arlington-GMAD
D - Doraville-GMAD	Z - Fremont-GMAD
L - Leeds-GMAD	#1 - Oshawa (Canadian Plt.)

**K - V6 229 (115 H.P.)	J - V8 267 (120 H.P.)
A - V6 231 (110 H.P.)	H - V8 305 (155 H.P.)
3 - V6 231 (170 H.P.)	

*** - Monte Carlo

EXAMPLE: The twenty-fifth Monte Carlo vehicle built at GMAD Baltimore 1AZ37 model (Monte Carlo Sport Coupe) with a V6-229 (115 H.P.) engine would bear VIN number 1Z37KAB400025.

Location Stamped on plate attached to top left hand of instrument panel.

TRANSMISSION IDENTIFICATION

Example: S0E01

Type	Source	Model Year	Production ^o
Designation	Designation	1980	Month & Date
7CA	B (Parma)	0	E01D*

7CA 3-Speed Auto.	V-6 engine	B - Parma
7WL 3-Speed Auto.	V-8 engine	Y - Toledo

Location:
3-Speed Automatic Stamped on right side transmission, above filler plug.

^o-Month: E denotes May; (see below) 01 denotes 1st day
Alpha Characters used in identifying the calendar Month

A - January	D - April	K - July	R - October
B - February	E - May	M - August	S - November
C - March	H - June	P - September	T - December

*-The letter "D" or "N" following the date numerals indicates day or night shift, on automatic only.

ENGINE IDENTIFICATION

Example: F1210CLB

Source	Production*	Type
Designation	Month & Date	Designation
F (Flint)	1210	CLB

3.8L, 229 Cubic Inch V-6 Base Engine (RPO LC3)

CLB - Regular engine, 3-Speed Automatic, 2-bbl. Carb.

3.8L, 231 Cubic Inch V-6 Engine, California (RPO LD5)

EF - Base engine, 3-Speed Automatic, 2-bbl. Carb.

3.8L, 231 Cubic Inch V-6 Engine (RPO LC8)

ED - Optional Engine, 3-Speed Automatic, 4-bbl. Carb.

4.4L, 267 Cubic Inch V-8 (RPO L39)

CPB - Optional engine, 3-Speed Automatic, 2-bbl. Carb.

5.0L, 305 Cubic Inch V-8, (RPO LG4)

CMC - Optional engine, 3-Speed Automatic, 4-bbl. Carb.

Location:

V6 & V8-cylinder engines Stamped on top front of right hand bank of cylinder and case, as close as possible to lower end of pad.

* - Month: December, 12; 10th day of December, 10.

REAR AXLE IDENTIFICATION

6RA - 2.29 Axle
6RB - 2.41 Axle
6RD - 2.73 Axle

Location, Identification Number
Stamped on front of right hand axle tube, 3 to 5 inches outboard of the carrier.

See Power Train Section for additional information.

EXTERIOR EQUIPMENT

STANDARD EXTERIOR EQUIPMENT

FRONT

MONTE CARLO

Bright Windshield Reveal Molding	X
Concealed Windshield Wipers with Non-Articulated Arms (F)	X
Dual Rectangular Parking Lamps, Clear Lenses with Amber Bulbs, Located Below Headlamps	X-N
Radiator Grille and Peripheral Moldings, Chrome Plated Plastic (C)	X-N
Headlamps, Rectangular, Dual(C)	X-N
Bright Headlamp Bezels (C)	X-N
"Monte Carlo" Nameplate in LH Lower Portion of Grille	X-N
Upright Mounted Monte Carlo Crest in Center of Front End Panel (C)	X
Body Colored Front Bumper with Bright Accent Strips (C)	X

SIDE

Sail Panel Crest	X
Bright LH Outside Rear View Mirror	X
Body Side Lower Molding - Bright with Blue-Gray Center (F & C)	X
Bright Drip Moldings	X
Bright Wheel Opening Moldings	X
Bright/Black B-Pillar Molding (F)	X
Bright Belt Bead Molding - Door and Quarter (F)	X
Wheel Trim Covers (C)	X
Bright Lift Bar Door Handles	X
Front Fender Nameplate Script - "Monte Carlo"	X
Rectangular Front Side Marker Lamp; Mounted in Front Fender (C)	X-N

REAR

Deck Lid Nameplate "Monte Carlo" Script and Bow Tie Above R.H. Taillamp (F)	X
Bright Rear Window Reveal Molding	X
Four-Segment Tail Lamps with Bright Bezel, Mounted in Rear End Panel, with Wrap-around Feature Forming Side Marker Lamps (Inboard portion, clear lens backup lamp) (F)	X
Monte Carlo Crest on Deck Lid Lock Cylinder Cover (F)	X
Bright License Plate Pocket Molding (F)	X
Bright Molding Along Lower Edge of Deck Lid (F)	X
Body Colored Rear Bumper with Bright Accent Strips (C)	X

(C) = Chevrolet Item
(F) = Fisher Item
N = New for 1980

STANDARD INTERIOR EQUIPMENT

ROOF AND PILLARS	MONTE CARLO
Headlining, Alpine Cloth over Thick Foam Padding (F)	X
Rear View Mirror 10" Prismatic - Textured Black Metal Vinyl Clad	X
Rear View Mirror Support, Bonded to W/S, Black Painted	X
Sunshade, Padded, Non-Hook, Victor Cloth Covered, Diagonal Break Line at Outboard Corner (F)	X
Roof Side Rail Garnish Moldings - Painted Aluminum (F)	X
Rear Window Moldings - Painted Aluminum (F)	X
Windshield Garnish Moldings - Painted Aluminum (F)	X
Rear Quarter Upper Trim Panel, Molded Plastic (F)	X
Coat Hooks, Plastic - Trim Color (F)	X
Center Dome Light - Plastic Lens (F)	X
Front Door Jamb Switch, Key Reminder and Dome Lamp, L.H. Pillar (F)	X
Front Door Jamb Switch for Dome Lamp R.H. Pillar (F)	X
SEATS AND FLOOR COVERING	
Front and Rear Seat Cushion and Backrest, Full Molded Foam (F)	X
Bench Type Seats, Split Front Seat Backrest, Specific Seat Trim Design (F)	X-M
Three Point Front Seat Outboard Belt System (Lap & Shoulder) with Single Locking Retractor (One per Side), Color-Coordinated (F)	X-M
Front Seat Center Lap Belt, Color-Coordinated (F)	X-M
Front Seat Head Restraints (F)	X
Package Shelf, Embossed Board (F)	X
Carpet, Floor Covering - Nylon Cut Pile (F)	X
Inertia Type Front Seat Back Locks (F)	X
Rear Passenger Compartment Ash Tray in Driver's Seat Back (F)	X
DOOR AND QUARTER PANEL	
Plastic Molded Front Door Lower Trim Panel, W/Armrest and Carpet-Covered Kick Panel (F)	X-M
Soft Trim Door Upper Panel with Pull Strap (F)	X
Pull Type Door Handle (F)	X
Rear Quarter Panel with Integral Armrest (F)	X
Window Control Handle Knobs, Clear Plastic (F)	X
Door Lock Buttons - Bright (F)	X
Front Door Locks, 2-Position Free Wheeling (F)	X
Rear Quarter Sidewalls - Vinyl Trimmed (F)	X
TRUNK COMPARTMENT	
Black Spatter Paint Trunk Compartment Finish (F)	X
Needled Polypropylene Trunk Floor Covering In Black, Extending Forward to Back of Rear Seat	X

(C) = Chevrolet Item
 (F) = Fisher Item
 (N) = New for 1980
 (M) = Modified for 1980

INTERIOR EQUIPMENT

STANDARD INTERIOR EQUIPMENT

INSTRUMENT PANEL AND STEERING WHEEL

MONTE CARLO

Glove Compartment, Ash Tray and Instrument Panel Courtesy Lamps (C)	X
Heater Control Light (C)	X
Temperature, Generator, Oil Pressure, Brake and Seat Belt Warning Lights (C)	X
Hi-Beam and Turn Signal Indicators (C)	X
Two-Speed Windshield Wiper and Washer Switch (Slide Type Depress to Wash) – Illuminated (C)	X
Lighting Control Knob, Black Barrel with Brushed Aluminum Face (C)	X
Black Hazard Flasher Knob (C)	X
Radio Knobs, Black Barrel with Brushed Aluminum Face (C)	X
Soft Black Turn Signal/Headlamp Dimmer and Transmission Shift Lever Knobs (C)	X
Steering Column Ignition Switch with Integral Steering Wheel and Transmission Lock (C)	X
Black Parking Brake Release Handle, Integrated into IP (C)	X
Black T-Handle Interior Hood Release (C)	X
Blended Air Heater (C)	X
Ash Tray, Tip Down Type, Under Center Portion of IP (C)	X
Cigarette Lighter Knob; Black Barrel with Brushed Aluminum Face (C)	X
85 MPH (140 KPH) Speedometer and Odometer, Clock and Fuel Gage (C)	X-M
Instrument Panel Pad Color-Keyed to Interior (C)	X-M
R.H. Trim Molding, Extending Horizontally Across Instrument Panel Pad. Simulated Woodgrain Finish (C)	X-N
Instrument Panel Astro-Ventilation Outlets (C)	X
Glove Compartment Door Lock (C)	X
“Monte Carlo” nameplate on Inst. Panel Pad, above Glove Compartment (F)	X
Round Instruments with simulated woodgrain on Cluster Carrier (C)	X-N
Bright-Finished Inst. Cluster Face Plate Trim Beads on Heater Control Panel, Radio Cover Panel and Air Cond. Outlet Cover (F)	X
Color Keyed Steering Wheel and Column	X
Dual Vent Control Knobs at L.H. and R.H. of Steering Column (C)	X
Soft Vinyl Steering Wheel and Shroud with Bright Band Inset into Rim, Shield Emblem and Simulated Woodgrain Applique on Shroud (C)	X-M
Plastic Cowl Kick Pads (C)	X
Electric Clock, Round (C)	X-M
Fuel Gage (“Unleaded Fuel Only”), Round (C)	X

GLASS

Laminated Safety Plate Glass Windshield (Thin Design)	X
Solid Safety Plate Backlight	X
Solid Safety Plate Side Windows	X

(C) = Chevrolet item
 (F) = Fisher item
 (N) = New for 1980
 (M) = Modified for 1980

EXTRA COST EQUIPMENT

EQUIPMENT

MODEL OPTIONS

	RPO	ACC.
Monte Carlo 'Landau' (see page 10 for content)	Z03	
Monte Carlo "Luxury Interior" (See page 10 for content)	Z06	
Monte Carlo "Sun Roof" (See page 11 for content)	CC1	

POWER TEAMS

3.8 Litre - V6 (231 CID)*	LD5	
3.8 Litre - V6 (231 CID)	LC8	
4.4 Litre V8 (267 CID)	L39	
5.0 Litre - V8 (305 CID)	LG4	
Axle Positraction	G80	
Axle Performance	G92	

FACTORY INSTALLED REGULAR PRODUCTION TIRES

P205/70R-14, Steel Belted Radial Ply, Wide White Stripe	QFK	
---	-----	--

* RPO LD5 V6 engine base in California.

EXTRA COST EQUIPMENT

EQUIPMENT	RPO	ACC
POWER ASSISTS		
Locks, Electric Door	AU3	
Rear Compartment Remote Control Electric Lock	A90	X
Sunroof	CA1	
Seat, 6-Way Power Seat Adjuster Electric Control	AG9	
Window, Electric Control	A31	
OTHER OPTIONS		
Air Conditioning, Four-Season (See page 12 for content)	C60	
Alarm, Theft		X
Battery, Heavy Duty	UA1	
Compass		X
Console, Front Compartment Floor (Requires Bucket Seats)	D55	
Container, Litter and Tissue Dispenser (Saddle type)		X
Defogger, Rear Window (Electric)	C49	
Special Instrumentation	U14	
Gauges, Instrument Panel	UF7	
Generator, 70-Amp Delcotron	K73	
Glass, Tinted - All Windows	A01	
Glass, Tinted - Windshield only (Fleet use and Canadian use only)	A02	
Guard, Vinyl Door Edge		X
Guard Door Edge Stainless Steel	B93	X
Harness, Trailering Wiring		X
Hitch, Trailer - Equalizing Type		X
Hitch, Trailer - Deadweight Type		X
Heater, Engine Block		X
Heavy Duty Cooling	V08	
Lighting, Auxiliary	TR9	
Engine Compartment Lamp (U26)		X
Instrument Compartment Courtesy Lamps (U29) (Standard)		
Glove Compartment Lamp (U27) (Standard)		X
Dome/Courtesy Lamp - Electronic Delay Switch (C94)		X
Luggage Compartment Lamp (U25)		X
Ash Tray Lamp (U28) (Standard)		X
"Headlamp On" Buzzer (T63)		
Litter Container	D24	X
Mats, Front and Rear, Color Keyed, 2 Front and 2 Rear	B37	X
Mirrors, Sport Outside Rear View Body Color - LH Remote Control and RH - Manual Control	D35	
Mirror, Outside Remote-Control, Rear View LH	D33	X
Mirror, Visor Vanity, RH	D34	X
Mirrors, Sport Outside Rear View Remote Control Body Color	D68	
Mirror, Illuminated Visor Vanity	D64	

EXTRA COST EQUIPMENT

EQUIPMENT	RPO	ACC.
OTHER OPTIONS		
Mirror, RH		X
Molding, Body Side - Color-Keyed Edges, Bright Vinyl Insert	BW2	
Molding, Side Window Belt	B85	
Molding, Lower Body Side	BX2	
Radio, Equipment: Radios, Pushbutton - Includes concealed w/s antenna. (*)		
AM Radio	U63	X
AM/FM Radio	U69	X
AM/FM/Stereo Radio	U58	X
Stereo Tape System with AM Radio	UM1	X
Stereo Tape System with AM/FM Radio	UM2	X
Radio AM/FM Stereo with Cassette Player	UN3	X
Radio AM/FM Monaural with Citizens Band Transceiver	UP5	X
Radio AM/FM Stereo with Citizens Band Transceiver	UP6	X
Speaker, Rear Seat	U80	X
Speakers, Dual Front (Forded with Turbo Engine and Monaural Radio)	UX6	
Antenna, Power	U75	
Roof Cover, Landau (Part of Z03 Option)	CB7	
Roof Cover, Vinyl	C09	
Radio, Citizens Band (+)		X
Seat, Safety - Child		X
Seat, Safety - Infant		X
Seat, 55/45 Passenger Front (Available only with Luxury Trim Level)	AM6	
Seat, Bucket	A51	
Speed Control, Automatic (only with Automatic Transmission)	K30	X
Steering Wheel, Comfortilt	N33	
Sun Roof, Steel, Power Operated	CA1	
Sun Roof (Twin Hatch Type) See page 11 for content	CC1	
Suspension, H.D. Front and Rear (Requires V8 engine)	F40	
Spotlight, Hand		X
Wheel Cover - Special Simulated Wire	N95	X
Wheel Rally 14 x 6 Hub Cap and Trim Ring (N.A. with Z03)	ZJ7	
Warmer, Interior Car		X
Intermittent Windshield Wiper System	CD4	

* Except Citizens Band Radio Equipment.
 + Citizens Band Radio includes power antenna.

RPO Z03 AND RPO Z06

MONTE CARLO 'LANDAU' OPTION RPO Z03

AVAILABILITY

Standard model 1AZ37

POWER TRAIN AVAILABILITY

Same as standard model.

CONTENT (In addition to or in place of standard equipment)

EXTERIOR

Specific Vinyl Cover on Front Portion of Roof.
Specific "Landau" Sail Panel Emblem.
Plastic Wheel Trim Cover.
Bright Roof Top and Sail Panel Moldings.

INTERIOR

Vanity Visor Mirror.
"Landau" Plaque on Instrument Panel Pad.

LUXURY INTERIOR OPTION RPO Z06

INTERIOR

Specific Door Trim Panel Design.
Specific 55/45 Bench Seat with Folding Arm Rest.
Specific Seat Trim Design (New).

MONTE CARLO "SUN ROOF" OPTION RPO CCI

(Twin Hatch Type)

AVAILABILITY

Standard model 1AZ37.

POWER TRAIN AVAILABILITY

Same as standard model.

CONTENT (In addition to or in place of standard equipment)

EXTERIOR

- Removable glass hatch panels.
- Narrow, bright molding across roof, at rear of hatch opening (CCI roof).
- Narrow, bright molding across roof at front of hatch opening.
- Body color windshield header panel.
- Narrow, black molding at front, rear and inner edge of removable panels.
- Wide, black molding with narrow bright drip molding at outer edge of removable panels.

INTERIOR

- Bright windshield reveal molding.
- Dual sail panel interior lamps, (replacing dome lamp).

14
15
16
17
18
19
20
21
22
23
24
25
26
27
28
29
30
31
32
33
34
35
36
37
38
39
40
41
42
43
44
45
46
47
48
49
50
51
52
53
54
55
56
57
58
59
60
61
62
63
64
65
66
67
68
69
70
71
72
73
74
75
76
77
78
79
80
81
82
83
84
85
86
87
88
89
90
91
92
93
94
95
96
97
98
99
100
101
102
103
104
105
106
107
108
109
110
111
112
113
114
115
116
117
118
119
120
121
122
123
124
125
126
127
128
129
130
131
132
133
134
135
136
137
138
139
140
141
142
143
144
145
146
147
148
149
150
151
152
153
154
155
156
157
158
159
160
161
162
163
164
165
166
167
168
169
170
171
172
173
174
175
176
177
178
179
180
181
182
183
184
185
186
187
188
189
190
191
192
193
194
195
196
197
198
199
200
201
202
203
204
205
206
207
208
209
210
211
212
213
214
215
216
217
218
219
220
221
222
223
224
225
226
227
228
229
230
231
232
233
234
235
236
237
238
239
240
241
242
243
244
245
246
247
248
249
250
251
252
253
254
255
256
257
258
259
260
261
262
263
264
265
266
267
268
269
270
271
272
273
274
275
276
277
278
279
280
281
282
283
284
285
286
287
288
289
290
291
292
293
294
295
296
297
298
299
300
301
302
303
304
305
306
307
308
309
310
311
312
313
314
315
316
317
318
319
320
321
322
323
324
325
326
327
328
329
330
331
332
333
334
335
336
337
338
339
340
341
342
343
344
345
346
347
348
349
350
351
352
353
354
355
356
357
358
359
360
361
362
363
364
365
366
367
368
369
370
371
372
373
374
375
376
377
378
379
380
381
382
383
384
385
386
387
388
389
390
391
392
393
394
395
396
397
398
399
400
401
402
403
404
405
406
407
408
409
410
411
412
413
414
415
416
417
418
419
420
421
422
423
424
425
426
427
428
429
430
431
432
433
434
435
436
437
438
439
440
441
442
443
444
445
446
447
448
449
450
451
452
453
454
455
456
457
458
459
460
461
462
463
464
465
466
467
468
469
470
471
472
473
474
475
476
477
478
479
480
481
482
483
484
485
486
487
488
489
490
491
492
493
494
495
496
497
498
499
500
501
502
503
504
505
506
507
508
509
510
511
512
513
514
515
516
517
518
519
520
521
522
523
524
525
526
527
528
529
530
531
532
533
534
535
536
537
538
539
540
541
542
543
544
545
546
547
548
549
550
551
552
553
554
555
556
557
558
559
560
561
562
563
564
565
566
567
568
569
570
571
572
573
574
575
576
577
578
579
580
581
582
583
584
585
586
587
588
589
590
591
592
593
594
595
596
597
598
599
600
601
602
603
604
605
606
607
608
609
610
611
612
613
614
615
616
617
618
619
620
621
622
623
624
625
626
627
628
629
630
631
632
633
634
635
636
637
638
639
640
641
642
643
644
645
646
647
648
649
650
651
652
653
654
655
656
657
658
659
660
661
662
663
664
665
666
667
668
669
670
671
672
673
674
675
676
677
678
679
680
681
682
683
684
685
686
687
688
689
690
691
692
693
694
695
696
697
698
699
700
701
702
703
704
705
706
707
708
709
710
711
712
713
714
715
716
717
718
719
720
721
722
723
724
725
726
727
728
729
730
731
732
733
734
735
736
737
738
739
740
741
742
743
744
745
746
747
748
749
750
751
752
753
754
755
756
757
758
759
760
761
762
763
764
765
766
767
768
769
770
771
772
773
774
775
776
777
778
779
780
781
782
783
784
785
786
787
788
789
790
791
792
793
794
795
796
797
798
799
800
801
802
803
804
805
806
807
808
809
810
811
812
813
814
815
816
817
818
819
820
821
822
823
824
825
826
827
828
829
830
831
832
833
834
835
836
837
838
839
840
841
842
843
844
845
846
847
848
849
850
851
852
853
854
855
856
857
858
859
860
861
862
863
864
865
866
867
868
869
870
871
872
873
874
875
876
877
878
879
880
881
882
883
884
885
886
887
888
889
890
891
892
893
894
895
896
897
898
899
900
901
902
903
904
905
906
907
908
909
910
911
912
913
914
915
916
917
918
919
920
921
922
923
924
925
926
927
928
929
930
931
932
933
934
935
936
937
938
939
940
941
942
943
944
945
946
947
948
949
950
951
952
953
954
955
956
957
958
959
960
961
962
963
964
965
966
967
968
969
970
971
972
973
974
975
976
977
978
979
980
981
982
983
984
985
986
987
988
989
990
991
992
993
994
995
996
997
998
999
1000

DIMENSIONS AND WEIGHTS

INTERIOR DIMENSIONS	2
LUGGAGE CAPACITY	2
EXTERIOR DIMENSIONS	3 & 4
VEHICLE WEIGHTS	5
OPTIONAL EQUIPMENT WEIGHTS	5

INTERIOR DIMENSIONS

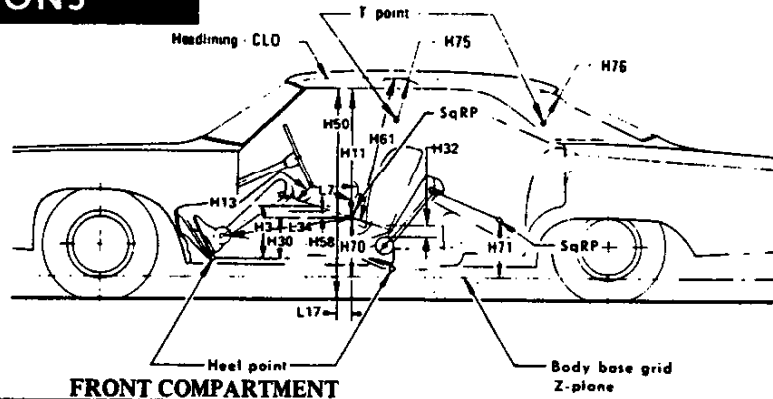

FRONT COMPARTMENT

CODE	DESCRIPTION	SPORT COUPE
H-3	Seat cushion height	282 (11.1)
H11	Entrance height	773 (30.4)
H13	Steering wheel to centerline of thigh	104 (4.1)
H30	SgRP to heel point (chair height)	228 (9.0)
H32	Seat cushion deflection	80 (3.2)
H50	Upper body opening to ground	1275 (50.2)
H58	H point rise - Design	26 (1.0)
H61	Effective headroom	956 (37.6)
H70	SgRP to body base grid	175 (6.9)
H75	Effective "T" point headroom	961 (37.8)
W3	Shoulder room	1430 (56.3)
W5	Hip room	1313 (51.7)
L7	Steering wheel torso clearance	340 (13.4)
L17	H point travel - Design	172 (6.8)
L34	Effective leg room	1086 (42.8)

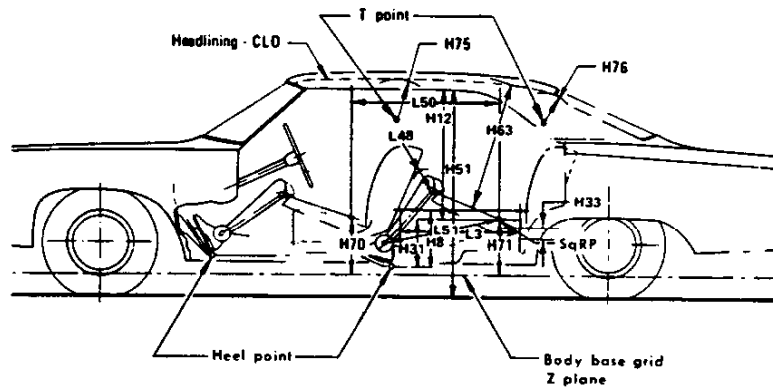

REAR COMPARTMENT

H8	Seat cushion height	340 (13.4)
H12	Entrance height	---
H31	SgRP to heel point (chair height)	264 (10.4)
H33	Seat cushion deflection	112 (4.4)
H51	Upper body opening to ground	---
H63	Effective headroom	961 (37.8)
H71	SgRP to body base grid	133 (5.2)
H76	Effective "T" point headroom	957 (37.7)
W4	Shoulder room	1419 (55.9)
W6	Hip room	1394 (54.9)
L3	Rear compartment room	682 (26.9)
L48	Knee clearance	53 (2.1)
L50	SgRP couple distance	817 (32.2)
L51	Effective leg room	923 (36.3)

LUGGAGE COMPARTMENT

H195	Liftover height	751 (29.6)
V1	Usable luggage capacity L (cu. ft.)	456 (16.1)

* Primary Dimensions are millimeters unless otherwise shown.

EXTERIOR DIMENSIONS

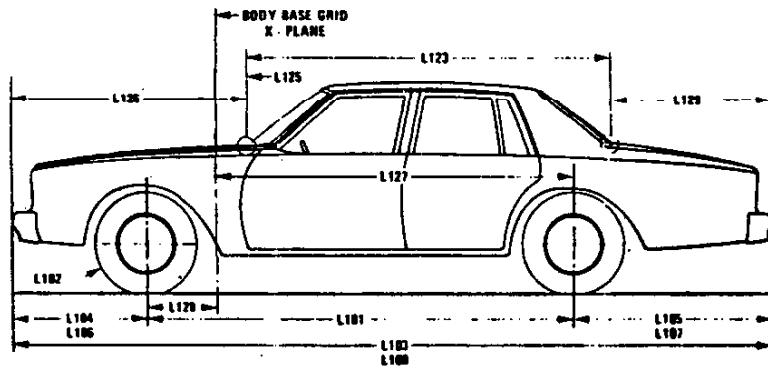

LENGTHS

CODE	DESCRIPTION	SPORT COUPE
L101	Wheelbase	2745 (108.1)
L102	Tire size (standard)	P205/70R14
L103	Overall length	5090 (200.4)
L104	Overhang front	1077 (42.4)
L105	Overhang, rear	1268 (49.9)
-	Overall length - less bumpers	4826 (190.0)
L123	Body upper structure length at car center line	2303 (90.7)
L125	Body base grid plane to windshield cowl point	158 (6.2)
L126	Front end length at center line	1511 (59.5)
L127	Rear wheel center line to body base grid line	2377 (93.6)
L128	Front wheel center line to body base grid line	- 368 (- 14.5)
L129	Rear end length at center line	1012 (39.8)
L30	Front of dash to body base grid	- 52 (- 2.1 in.)

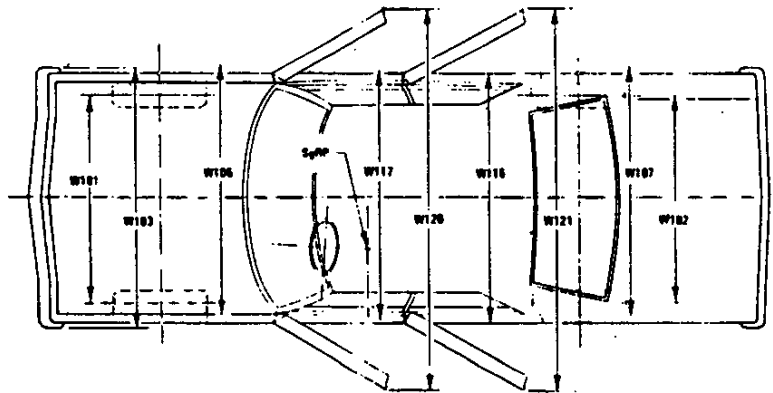

WIDTHS

W101	Tread - front	1486 (58.5)
W102	Tread - rear	1467 (57.8)
W103	Maximum overall width of car	1816 (71.5)
W106	Front fender overall width	1816 (71.5)
W107	Rear fender overall width	1816 (71.5)
W116	Maximum overall width of body	1816 (71.5)
W117	Body width at SgRP - front	1783 (70.2)
W120	Overall car width, front doors open	3989 (157.0)
W121	Overall car width, rear doors open	---

*Primary Dimensions are millimeters unless otherwise shown.

EXTERIOR DIMENSIONS

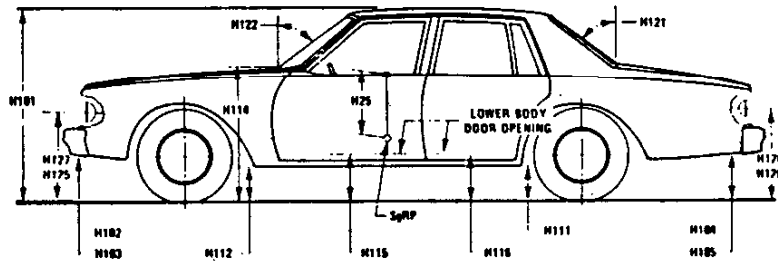

HEIGHTS

CODE	DESCRIPTION	SPORT COUPE
H101	Overall height (design)	1368 (53.9)
H102	Front bumper to ground	332 (13.1)
H104	Rear bumper to ground	316 (12.5)
H111	Rocker panel to ground - rear	208 (8.2)
H112	Rocker panel to ground - front	215 (8.5)
H114	Hood at rear to ground	974 (38.3)
H115	Step height - front (design)	347 (13.7)
H116	Step height - rear (design)	---
H125	Headlamp to ground	659 (25.9)
H126	Tail lamp to ground	616 (24.3)
H136	Body O line to ground - front	327 (12.9)
H137	Body O line to ground - rear	317 (12.5)

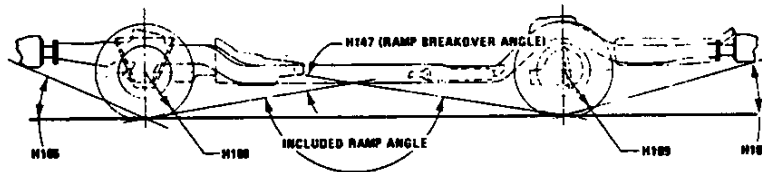
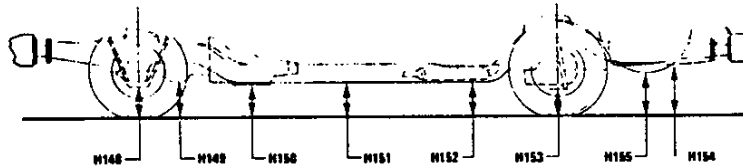

CLEARANCES

H106	Angle of approach (degrees)	19.20°
H107	Angle of departure (degrees)	14.80°
H147	Ramp breakover angle (degrees)	13.43°
H148	Front suspension to ground	157 (6.2)
H149	Oil pan to ground	170 (6.7)
H150	Flywheel housing to ground	177 (7.0)
H151	Frame to ground	163 (6.4)
H152	Exhaust system to ground	229 (9.0)
H153	Rear axle to ground	149 (5.9)
H154	Fuel tank to ground	198 (7.89)
H155	Tire well to ground	---
H156	Minimum ground clearance	118 (4.6) (a)

(a) Rear shock absorber bracket.

* Primary Dimensions are millimeters unless otherwise shown.

VEHICLE WEIGHTS

MODEL TYPE								
MODEL DESIGNATION	BASE ENGINE	VEHICLE TYPE	SHIPPING WEIGHT			CURB WEIGHT		
			Front	Rear	Total	Front	Rear	Total
1AZ37	3.8 (229 CID) V6, LC3	2-Door Sport Coupe	829.1 (1828)	579.3 (1277)	1408.4 (3105)	820.9 (1810)	629.4 (1387)	1450.3 (3197)

SHIPPING WEIGHTS: Weight of basic vehicle with regular equipment, including grease, oil and (3) gallons of gasoline, and engine coolant to capacity.

CURB WEIGHT: Shipping weight plus gasoline to capacity.

For total shipping, and curb, weights of vehicles equipped with the following options, add to, or deduct from the base vehicle weight (lbs.).

OPTIONAL EQUIPMENT

RPO	OPTION	WITH	WEIGHT METRIC (kg) - ENGLISH
AU3	Electric Door Locks		1.8 (4 lb.)
A31	Power Windows		3.6 (8 lb.)
AG1	Power Seat 6-Way Bench		8.2 (18 lb.)
AM6	Power Seat 6-Way 55/45 Seat		5.4 (12 lb.)
B37	Front and Rear Floor Mats		3.2 (7 lb.)
CA1	Electric - Sun Roof		16.8 (37 lb.)
C09	Vinyl Roof Cover (Padded)		3.2 (7 lb.)
C60	Air Conditioning	Used with LC3 V6 Engine	36.3 (80 lb.)
		Used with LD5 & LC8 V6 Engines	27.2 (60 lb.)
		Used with L39 & LG4 V8 Engines	26.8 (59 lb.)
D55	Console	Used with Automatic Transmission	6.2 (13.5 lb.)
F41	Heavy Duty Suspension Front & Rear		9.1 (20 lb.)
K30	Automatic Speed Control		2.3 (5 lb.)
UA1	Battery Heavy Duty	Used with V6 Engine	6.8 (15 lb.)
		Used with V8 Engine	5.0 (11 lb.)
UM1	Radio AM Pushbutton & Tape		6.3 (14 lb.)
UM2	Radio AM/FM Pushbutton & Tape		6.3 (14 lb.)
UN3	Radio AM/FM Stereo with Cassette Player		6.3 (14 lb.)
UP5	Radio AM/FM Monaural with Citizens Band Transceiver		3.2 (7 lb.)
UP6	Radio AM/FM Stereo with Citizens Band Transceiver		5.9 (13 lb.)
U58	Radio AM/FM Stereo		5.9 (13 lb.)
U63	Radio AM Pushbutton		2.3 (5 lb.)
U69	Radio AM/FM Pushbutton		2.7 (6 lb.)
U92	Dual Front & Rear Speakers		1.8 (4 lb.)
V08	Heavy Duty Cooling		1.8 (4 lb.)
ZJ7	Special Wheels, Hub Caps & Trim Rings		5.0 (11 lb.)
LC8	3.8 Liter (231 CID) V6 Engine	3-Speed Automatic Transmission	25.4 (56 lb.)
LD5	3.8 Liter (231 CID) V6 Engine	3-Speed Automatic Transmission	5.0 (11 lb.)
L39	4.4 Liter (267 CID) V8 Engine	3-Speed Automatic Transmission	52.2 (115 lb.)
LG4	5.0 Liter (305 CID) V8 Engine	3-Speed Automatic Transmission	56.2 (124 lb.)

*Primary mass weights are in kilograms (pounds).



BODY

EXTERIOR PAINT PROCESS	2
EXTERIOR COLORS AND VINYL ROOF COMBINATIONS	3
EXTERIOR-INTERIOR COLORS	4, 5, 6
BODY CONSTRUCTION AND GLASS AREA	7

EXTERIOR PAINT PROCESS

1. **RUSTPROOFING.** Assembled car bodies are chemically sprayed to clean and etch the metal surfaces for corrosion resistance and paint adhesion. Unassembled sheet metal parts follow the same process.
- *2. **BODY PRIMER.** Four corrosion resistant primers, specially formulated, are hand sprayed on the body in areas where rust might develop. Lower areas considered especially vulnerable are coated with another rust inhibiting compound.
- *3. **SHEET METAL PRIMER** is applied to all outside and inside surfaces of front fenders and hoods. The parts are mechanically dipped or flow-coated to insure coating in all seams and secluded areas, and baked at 390 degrees F. for 30 minutes. A coat of sealer is then applied by hand spray to all surfaces requiring lacquer.
4. **FLASH PRIMER AND PRIMER-SURFACER COATS.** An air-dry flash primer coat is hand sprayed on surfaces below the body belt line. Then a gray primer-surfacer coat is hand sprayed on all outside surfaces of the body and oven baked for 45 minutes at 285 degrees F.
5. **INITIAL SANDING.** Power wet sanding, followed by hand sanding, is done on all body surfaces requiring lacquering. This insures a smooth surface for the lacquer finish. To remove the water, the body is wiped and run through an infra-red oven.
6. **LACQUERING.** Three coats of acrylic lacquer are applied on the exterior surfaces of the body and sheet metal parts to build up a finish of the required thickness for each color.
7. **INITIAL BAKING.** To harden the paint for two tones, the body and sheet metal parts are baked for approximately 10 minutes at 200 degrees F.
8. **FINAL BAKING.** To assure a durable, hard, high luster finish the lacquer is baked for 30 minutes at 325 degrees F. Reheating the lacquer permits paint film to soften, allowing surface blemishes to disappear during the thermo-reflow process.
9. **UNDERCOATING.** To block out road noise, an asbestos fiber sound deadener with asphalt base is sprayed inside the wheel housings and on the bottom of the underbody at designated areas.
10. **PAINT REPAIR AND PROTECTION.** Mars, nicks, or scratches that occur during final assembly are corrected at the factory before shipment. When required, light "slush" polishing brings painted surfaces to a high luster finish. Wax is applied to all horizontal surfaces of each vehicle and polished out for protection during shipment. The wax contains no silicones, thus eliminating any paint contamination problem.

* Plants employing the Elpo Process (see Monza for description) preclude need for these priming steps.

EXTERIOR-INTERIOR COLORS

1980 MONTE CARLO EXTERIOR, COLOR VINYL ROOF COMBINATIONS

EXTERIOR COLOR	CODE	FISHER W.A.	VINYL ROOF COLORS						
			11T C/O WHITE	19T C/O BLACK	21T LT. BLUE	44T DK. GREEN	63T LT. CAMEL	76T DK. CLARET	85T GRAY
White C/O	11	3967	X	X			X	X	
Silver Met. C/O	15	7022		X				X	X
Black C/O	19	848		X				X	
Lt. Blue Met.	21	7102		X	X				
Dk. Blue Met.	29	7103		X			X		X
Dk. Green Met.	44	7105				X	X		
Yellow	50	7100		X					
Beige	59	7084		X				X	
Lt. Camel Met.	63	7136					X		
Med. Camel Met.	69	7137		X			X		
Claret Met.	75	7111		X				X	X
Dk. Claret Met.	76	7112						X	X
Cinnabar	77	7104		X					X
Gray	85	7101						X	X

EXTERIOR-INTERIOR COLORS

1980 MONTE CARLO EXTERIOR-INTERIOR COMBINATIONS

EXTERIOR COLOR	CODE	INTERIOR TRIM					
		BLACK	BLUE	GREEN	CAMEL	CLARET	OYSTER
White C/O	11	X	X	X	X	X	X
Silver Met. C/O	15	X	X			X	X
Dk. Claret Met.	76	X			X	X	X
Dk. Blue Met.	29	X	X		X		X
Black C/O	19	X	X	X	X	X	X
Lt. Blue Met.	21	X	X				X
Beige	59	X	X	X	X	X	
Dk. Green Met.	44			X	X		
Gray	85	X	X			X	X
Yellow	50	X			X		X
Lt. Camel Met.	63	X			X		
Med. Camel Met.	69	X			X		X
Cinnabar	77	X			X		X
Claret	75	X				X	X

1980 MONTE CARLO 'SPECIAL A' INTERIOR COLOR COMBINATIONS

MODEL	Seat Type	INTERIOR TRIM											
		Black		Dk. Blue		Willow Green		Camel Tan		Claret		Oyster	
		Cloth	Vinyl	Cloth	Vinyl	Cloth	Vinyl	Cloth	Vinyl	Cloth	Vinyl	Cloth	
Monte Carlo – 1AZ00 Coupe (37)	(A52) Bench	19G	26W	26G	44W			62W	62G	79W	79G	12W	
	(A51) Bucket	19G	26W	26G	44W			62W	62G	79W	79G	12W	
Monte Carlo – 1AZ00 Coupe (37) w/RPO ZY7 Special Trim*	(A52) Bench	19B	26Z	26B	44Z			62Z	62B	79Z	79B	12Z	
	(A51) Bucket	19B	26Z	26B	44Z			62Z	62B	79Z	79B	12Z	
Monte Carlo Luxury Coupe (37)	(AM6) 55-45			26H		44H		62H			79H	(1) 06Y	12H

CLOTH AND VINYL USAGE

W, Z – Sierra vinyl

B, G – Bedford knit corduroy cloth

H – Sumatra velour cloth; Dover bolster

Y – Tetra vinyl

(1) Includes Camel Tan Cowl Kick Panels, Carpet, Door Pull Strap Facings and Seat Welts, and Dk. Brown/Cream (No. 941) Seat, Door Trim and Rear Quarter Trim Accent Ribbons. Instrument Panel is Dark Camel Tan and Package Shelf is Dark Gray.

* RPO ZY7 special interior trim, consists of luxury door and quarter trim panels with cloth inserts.

EXTERIOR-INTERIOR COLORS

**1980 MONTE CARLO (1AZ37)
BODY SIDE MOLDING AND STRIPES WITH CUSTOM TWO-TONE (RPO D84)
NO COLOR OVERRIDES ARE ALLOWED**

CUSTOM TWO-TONE EXTERIOR COLORS				BODY SIDE STRIPE COLORS		RPO BW2 BODY SIDE MOLDING		RPO Z03 VINYL TOP COLOR	
BODY (U & L)		ACCENT (M)							
Silver Met. WA 7022	15	Black WA 848	19	Red /Black	WMH 4409 WMH 848	Gray	85Q	Black	19T
White WA 3967	11	Gray WA 7101	85	Claret /Silver	WMH 7111 WMH 4575	White	11Q	Gray	85T
Dk. Blue Met. WA 7103	29	Lt. Blue Met. WA 7102	21	Silver /Blue	WMH 4575 WMH 7187	Black	19Q	Lt. Blue Met.	21T
Beige WA 7084	59	Lt. Camel Met. WA 7136	63	Gold /Brown	WMH 7083 WMH 7231	Lt. Camel Met.	63Q	Lt. Camel Met.	63T
Lt. Camel Met. WA 7136	63	Black WA 848	19	Gold /Brown	WMH 7083 WMH 7231	Lt. Camel Met.	63Q	Black	19T
Claret Met. WA 7111	75	Dk. Claret Met. WA 7112	76	Gold /Black	WMH 7083 WMH 848	Dk. Claret Met.	76Q	Dk. Claret Met.	76T
Gray WA 7101	85	Dk. Claret Met. WA 7112	76	Claret /Silver	WMH 7111 WMH 4575	Gray	85Q	Dk. Claret Met.	76T

1980 MONTE CARLO BODY SIDE MOLDING AND STRIPE

RPO D85 – BODY SIDE ACCENT STRIPE

RPO BW2 – BODY SIDE MOLDING EQUIPMENT

STRIPE IDENTIFICATION

COLOR		PAINT (1AZ37 Only)
11A	White	WSA 3967
13A	Silver	WSA 4609
19A	Black	WSA 848
27A	Blue	WSA 7187
54A	Gold	WSA 7236
68A	Brown	WSA 7231
74A	Red	WSA 4409
76A	Dk. Claret	WSA 7237

MOLDING IDENTIFICATION		
11Q	White	WPV 3967
19Q	Black	WPV 848
21Q	Lt. Blue Met.	WPV 7102
63Q	Lt. Camel Met.	WPV 7136
76Q	Dk. Claret Met.	WPV 7112
85Q	Gray	WPV 7101

EXTERIOR-INTERIOR COLORS

1980 MONTE CARLO, STRIPE, MOLDING, VINYL TOP, AND EXTERIOR, INTERIOR COMBINATIONS

		INTERIOR TRIM COLOR							
		BLACK	OYSTER	BLUE	CAMEL	CLARET	GREEN		
White	11	Stripe Mldg. V. Top	Black White A, C	Red White X A	Blue White X A	Gold White X A, F	Dk. Claret Met. White X A, G	Gold White X A	X
Silver	15	Stripe Mldg. V. Top	Black Gray C	Red Gray X N/A	Blue Gray X N/A	X	Dk. Claret Met. Gray G	X	
Black	19	Stripe Mldg. V. Top	Gold Black C	Silver Black X B, C	Blue Black X C	Gold Black X C, F	Red Black X C, G	Gold Black X C	X
Lt. Blue Met.	21	Stripe Mldg. V. Top	Silver Lt. Blue Met. C, D	Silver Lt. Blue Met. X D	Silver Lt. Blue Met. Y D, A	X			
Dk. Blue Met.	29	Stripe Mldg. V. Top	Silver Black C	Silver Black Y B	Blue Black X A, C	Gold Black X F	X		
Beige	59	Stripe Mldg. V. Top	Brown Lt. Camel Met. C	X	Brown Lt. Camel Met. N/A	Brown Lt. Camel Met. X F	Dk. Claret Met. Lt. Camel Met. X G	Brown Lt. Camel Met. X N/A	Y
Lt. Camel Met.	63	Stripe Mldg. V. Top	Brown Lt. Camel Met. F	Y		Brown Lt. Camel Met. F, A	X		
Med. Camel Met.	69	Stripe Mldg. V. Top	Gold Lt. Camel Met. C	X N/A	Y	Brown Lt. Camel Met. F	X		
Claret Met.	75	Stripe Mldg. V. Top	Gold Dk. Claret Met. C	X B	Silver Dk. Claret Met. X		Gold Dk. Claret Met. G, A	X	
Dk. Claret Met.	76	Stripe Mldg. V. Top	Gold Dk. Claret Met. G	Y B, G	Silver Dk. Claret Met. X	Gold Dk. Claret Met. G	X G, A	Gold Dk. Claret Met. X	
Yellow	50	Stripe Mldg. V. Top	Black Black C	X N/A	White White Y	Brown Gray N/A	X		
Cinnabar	77	Stripe Mldg. V. Top	Black Black C	X B	White Gray X	Gold Gray N/A	X		
Gray	85	Stripe Mldg. V. Top	Black Gray B	X B	White Gray X B	Blue Gray X B	Brown Gray X B	Dk. Claret Met. Gray X B, G	X
Dk. Green Met.	44	Stripe Mldg. V. Top	Gold Black E	Y E	Silver Black Y	Gold Black E, F	X	Gold Black E, A	X

X = RECOMMENDED
Y = ACCEPTABLE
N/A = NOT ACCEPTABLE

VINYL ROOF COLOR:

A = White
B = Gray
C = Black
D = Lt. Blue Met.
E = Dk. Green Met.
F = Lt. Camel Met.
G = Dk. Claret Met.

BODY CONSTRUCTION AND GLASS AREA

GENERAL

Type Unisteel, with cowl, roof, underbody and body panels welded to form body shell. Doors, front and rear lids are of double-panel construction and hinge assembled to body. Separate frame and bolt-on front end sheet metal, with protective front inner plastic fender skirts. Side guard door beams. Air gap design windshield pillar molding. Contoured windshield header. Cargo guard luggage barrier. Double panel roof. Open channel rocker panels.

DOORS AND LOCKS

Door construction Double steel panels, hinged at front
 Door handles Exterior, lift bar with fork type door locks. Inside, push-button locks and 2-position free-wheeling inside door handles on all doors.
 Front door glass Full window

HOOD AND TRUNK LID

Type Counterbalanced, with spring loaded toggle action hinges on rear of hood and boxed hinges on trunk lid with torsion rod. Two hood stop pins mounted on cowl.
 Hood Release Internal, to left of steering column under instrument panel.

VENTILATION

Dual-mode, modular chamber system. Blower fan circulates upper air through instrument panel outlets. Lower air circulation provided at highway speeds through outlets under instrument panel.

SEAT CONSTRUCTION

Type
 All seat cushions and backrests Formed polyfoam

WINDSHIELD WIPERS

Type Concealed dual 2-speed electric
 Linkage Parallel acting

HEADLIGHTS

Type Dual-rectangular "Sealed Beam" units

SPARE TIRE AND TOOLS

Location Compact spare mounted upright in well at R.H. quarter of trunk floor. Tools consist of bumper jack with combination lever handle and wheel nut wrench stored at side of spare tire.

BODY GLASS VISIBILITY AREA ⊕

Windshield	8786 (1361.8 in. ²)
Front Door Window	7487 (1160.5 in. ²)
Rear Quarter Window	2425 (375.9 in. ²)
Rear Window	4660 (722.3 in. ²)
Total Area (Sq. In.)	23358 (3620.5 in. ²)

All window glass curved safety solid plate except curved laminated safety windshield.

⊕Primary dimensions cm²(secondary dimensions in.²)



CHASSIS

FRAME AND FRONT SUSPENSION	2-3
STEERING, DRIVELINE, WHEELS AND TIRES	4
REAR AXLE AND SUSPENSION	5
BRAKES	6
BULBS AND LAMPS	7
FUSES AND CIRCUIT BREAKERS	8

FRAME AND FRONT SUSPENSION

FRAME

Description Full perimeter frame with sigma section side rails, boxed section members forward and rearward of side rails, welded front and rear suspension crossmembers with transmission support of tubular construction.

Body Mountings Integral body mounting provisions. 7 each side of frame - 10 double cushions, 4 single cushions.

FRONT SUSPENSION

Description Independent, SLA type with coil springs and concentric shock absorbers, and spherically jointed steering knuckles for each wheel.

Wheel travel (design) - mm (in.)
 Total 182 (7.16)
 Jounce 90 (3.54)
 Rebound 92 (3.62)
 Wheel to spring, travel ratio 2.09:1

CONTROL ARMS

Description Reinforced steel stamping with pre-loaded, steel encased rubber bushings at pivot.

STEERING KNUCKLES

Description Nodular iron with integral steering arm

Spindle diameters - mm (in.)
 Inner bearing 31.7271-31.7475 (1.25)
 Outer bearing 21.4 (.844)
 Spindle thread size UNEF-3A (modified)
 Wheel bearing
 Type Taper roller
 Number Two per spindle

SPHERICAL JOINTS

Type Ball studs, upper self-adjusting for wear
 Bearing surfaces
 Upper Teflon-coated composite on phenolic
 Lower Sintered iron

SHOCK ABSORBERS

Type Direct, double-acting hydraulic
 Piston diameter 25 mm (1.00)

STABILIZER BAR

Type Link
 Material HR steel
 Diameter - mm (in.)
 V-6 engines 27 (1.06)
 V-8 engines 29 (1.14)

FRONT WHEEL ALIGNMENT (Curb)

Camber (degrees) +0.5 ± 0.8
 Caster (degrees) +3.0 ± 1
 Toe (degrees)15 ± .10
 Steering Axis Inclination 7.86° @ 1° camber

GENERAL SUSPENSION PROVISIONS

Car leveling Front stabilizer bar
 Anti-dive control Angle of front upper control arm
 Anti-squat control Rear suspension geometry

FRAME AND FRONT SUSPENSION

FRONT SPRINGS

Selected from a family of coil springs by Electronic Data Processing which identifies the correct springs for the weight of the vehicle including optional equipment ordered by the customer.

FRONT SPRING SPECIFICATIONS

Part No.	Assy. Code	Cut-Off Length		Wire Dia.		Total Coils	Deflection Rate		Heights			
		mm	in	mm	in		N/mm	lbs/in	Free		Working	
									mm	in	mm @ N	in @ lbs
460627	AAW	2953	116.3	15.6	.61	7.311	52.5	300	393.9	15.51	260 @ 7030	10.24 @ 1580
460628	AAX	3064	120.6	15.8	.62	8.094	52.5	300	399.0	15.71	260 @ 7300	10.24 @ 1641
460629	AAZ	3064	120.6	15.8	.62	8.094	52.5	300	404.2	15.91	260 @ 7570	10.24 @ 1702
460678	ADS	3151	124.0	16.0	.63	8.511	52.5	300	409.3	16.11	260 @ 7840	10.24 @ 1763
460679	ADT	3210	126.4	16.1	.63	8.661	52.5	300	414.5	16.31	260 @ 8110	10.24 @ 1823
460681	ADW	3134	123.4	16.4	.65	8.440	58.0	330	406.7	16.01	260 @ 8510	10.24 @ 1913
460683	ADY	3114	122.6	16.8	.66	8.362	64.0	365	400.3	15.76	260 @ 8980	10.24 @ 2019
460686	AFB	3112	122.5	17.2	.68	8.327	70.0	400	394.6	15.54	260 @ 9420	10.24 @ 2118

STEERING, DRIVELINE, WHEELS AND TIRES

STEERING

Wheel	
Type	Round with center shroud
Diameter - mm (in.)	381.0 (15)
Optional	Tilt; universally jointed steering shaft at base of steering wheel.
Column	
Energy absorbing - mast jacket, shift tube and steering shaft designed to collapse under various front impact conditions.	
Gear - Power (Standard)	
Type	Integral, recirculating ball nut with hydraulic pressure provided from a vane type pump.
Ratios	
Gear	14.0:1
Overall	15.3:1
Number of turns, lock to lock	3.3
Linkage	Parallelogram, front of wheels
Turning Diameters - m (ft.)	
Outside front, wall to wall	12.4 (40.5)
Outside front, curb to curb	11.3 (37.2)

DRIVELINE

Type	Tubular, exposed
Number Used	One
Diameter (O.D.) - mm (in.)	63.5 (2.5)
Length (C/L of U joints) - mm (in.) ..	1331.5 (52.42)
Wall Thickness - mm (in.)	1.65 (0.065)
Universal Joints	
Type	Single cardan
Number used	Two
Bearings	Pre-pack, anti-friction

WHEELS, REGULAR PRODUCTION

Type	Short spoke spider
Size	14 x 6JJ
Offset	'0'
Attachment to Hub	
Type	5 hex nuts
Thread size	7/16-20 UNF 2-B
Bolt circle diameter	4.75

WHEELS, OPTIONAL

Type	Rally
Size	14 x 6JJ
Offset	'0'

WHEEL, SPARE (COMPACT TIRE)

Size	15 x 4
Offset	25 mm (1.0 in.)

TIRES, STANDARD EQUIPMENT

Type	Steel belted radial
Size	P205/70R-14
Sidewall	
Base	Blackwall
Optional	White stripe
Static Loaded Radius - mm (in.)	287.8 (11.3)
Loaded rev/km @ 72 km/hr	508
Loaded rev/mi @ 45 mph	818
Capacity @ 179 kPa (26 psi)	535 (1180)

SPARE TIRE

Base	Compact
Type	Bias ply
Size	T125/70D15
Optional	
Availability	With limited slip differential
Type	Stowaway
Size	P195/75-14
Mounting	Upright in luggage compartment

REAR AXLE AND SUSPENSION

REAR AXLE

Description Semi-floating axle shafts, housing consists of two welded tubes pressed and welded into crossbore of cast iron carrier. Carrier contains an overhung pinion hypoid drive and supported by two taper roller bearings.

Drive pinion vertical offset 38 mm (1.50)

Hypoid gear PD (See Power Train Section)
Page 2 for application

Pinion bearing adjustment Shim

Lubricant

Type SAE GL-5

Viscosity 80W-90

Capacity 1.54 litres (3.25 pts.)

AXLE SHAFT

Type Forged and hardened steel with integral drive flange

Wheel bearings Single row cylindrical roller, one per wheel

Oil Seal Steel encased spring loaded synthetic rubber

RING AND PINION GEAR TOOTH COMBINATIONS

2.29 Ratio 17, 39

2.41 Ratio 17, 41

2.73 Ratio 15, 41

LIMITED SLIP DIFFERENTIAL (See Power Trains)

Type Two pinion with multiple disk clutch

REAR SUSPENSION

Description Link type; 2 upper and 2 lower control arms supporting rear axle. Drive and torque taken through control arms.

Wheel travel (design)

Total 220 mm (8.66)

Jounce 107 mm (4.21)

Rebound 113 mm (4.45)

Wheel to spring, travel ratio 0.98:1

SHOCK ABSORBERS

Type Direct, double-acting, hydraulic

Piston diameter 25 mm (1.00)

STABILIZER BAR

Type Link

Material HR steel

Diameter - mm (in.)

V-6 16 (.63)

V-8 19 (.75)

REAR SPRINGS

Selected from a family of coil springs by Electronic Data Processing which identifies the correct springs for the weight of the vehicle including optional equipment ordered by the customer.

REAR SPRING SPECIFICATIONS

Part No.	Assy. Code	Cut-Off Length		Wire Dia.		Total Coils	Deflection Rate		Heights			
		mm	in	mm	in		N/mm	lbs/in	Free		Working	
									mm	in	mm @ N	in @ lbs
496094	YZ	2296.2	90.4	12.57	.495	5.57	17.5	100	381.0	15.00	254 @ 2224	10 @ 500
485709	SR	2428.2	95.6	12.80	.504	5.83	17.5	100	393.7	15.50	254 @ 2446	10 @ 550
485710	SS	2689.9	105.9	13.23	.521	6.36	17.5	100	406.4	16.00	254 @ 2668	10 @ 600
485711	TT	2689.9	105.9	13.23	.521	6.36	17.5	100	419.1	16.50	254 @ 2892	10 @ 650

BRAKES

General	Application		Power - Standard
	Type		Disc front and drum rear
	System		Dual circuit hydraulic system with warning light and self adjusting features - metering and proportioning valves provide balance between front and rear brakes
Front Brakes	Type		Disc - single piston floating caliper
	Material		Cast iron - vented
	Diameter and Width - mm (in.)		266.7 x 26.2 (10.5 x 1.03)
	Lining material		Compression molded asbestos composition
	Method of attachment		Riveted
	Lining size (length x width x thickness)	Inboard - mm (in.)	125 x 48.44 x 11.04 (4.92 x 1.91 x .435)
		Outboard - mm (in.)	125 x 48.44 x 11.04 (4.92 x 1.91 x .435)
	Lining area-cm ² (in. ²)		242.4 (37.59)
	Effective area-cm ² (in. ²)		204.4 (31.69)
	Swept area-cm ² (in. ²)		1236.2 (191.68)
Piston diameter - mm (in.)		63.5 (2.5)	
Rear Brakes	Type		Finned drum - composite, web cast into rim
	Material		Web - HR steel; Rim - Cast alloy iron (a)
	Diameter and Width - mm (in.)		241.3 x 50.8 (9.5 x 2.0)
	Lining material		Molded asbestos composition
	Method of attachment		Riveted
	Lining size (length x width x thickness)	Primary - mm (in.)	192.5 x 51.0 x 4.98 (7.58 x 2.0 x .196)
		Secondary - mm (in.)	249.6 x 51.0 x 6.75 (9.83 x 2.0 x .266)
	Lining area-cm ² (in. ²)		449.2 (69.64)
	Effective area-cm ² (in. ²)		411.09 (63.7)
	Swept area-cm ² (in. ²)		748.77 (116.1)
Piston diameter - mm (in.)		19.05 (0.75)	
Apply System	Master cylinder diameter - mm (in.)		24 (0.94)
	Piston travel - mm (in.)		33.33 (1.31)
	Pedal travel - mm (in.)		134.4 (5.29)
	Pedal ratio		3.50:1
	Line pressure @ 100 lb. pedal load		700
Parking Brake	Type		Mechanical - Pull rods and cables operate rear service brakes; parking brake 'ON' warning light provided.
	Control		Pendulum foot pedal; released by "T" handle located on instrument panel left of steering wheel
	Total effective area - cm ² (in. ²)		63.7

(a) Finned aluminum drums with California 5.0 Liter V-8 engine and Turbocharged (RPO LC8) V-6 engine.

BULBS AND LAMPS

BULBS AND LAMPS	NUMBER REQUIRED AND TRADE NUMBER	CANDLE POWER PER LAMP
Ash tray lamp	1-1445	.7
Backing lamps	2-1156	32
Brake warning - alarm	1-168	3
Check engine indicator	1-194	2
Courtesy - Instrument panel	2-906	6
Directional signal indicators	2-194	2
Dome	1-561	12
Dome & reading lamp	2-1004	15
Generator indicator	1-194	2
Glove compartment	1-1895	2
Headlamp	Outer 2-6052	High beam 65W
		Low beam 55W
	Inner-Std 2-4651	High beam 50W
	RPO TT5 2H4651	High beam 50W
Headlamp hi-beam indicator	1-194	2
Heater or A/C controls	1-194	2
Instrument cluster	7-168	3
License plate, rear	2-194	3
Luggage compartment	1-1003	15
Oil pressure indicator	1-194	2
Parking		
Park		2.2
Turn	1157NA	24
Radio dial RPO U63 and/or U69	1-194	2
Radio dial and indicator RPO U58	1-194	2
Radio dial and indicator RPO UM1 and/or UM2	2-37	5
Radio dial and indicator light (RPO UP5 & 6)	1-194	2
Radio dial light ind. (RPO UN3)	2-37	5
Seat belt warning indicator	1-194	2
Side Marker - Front	2-194	2
Tail		
Tail	2-194	2
Stop and turn lamps	4-1157	32-3
Temperature indicator	1-194	2
Underhood	1-93	15
W/S washer and light indicator	1-194	2

FUSES AND CIRCUIT BREAKERS

CIRCUIT	TYPE OF PROTECTION	LOCATION AND CIRCUIT*
Air conditioning	30 amp CB	In line
Antenna, power	20 amp fuse	Fuse panel (f)
Back-up lamps	20 amp fuse	Fuse panel (d)
Brake alarm lamp	20 amp fuse	Fuse panel (e)
Brake alarm lamp	20 amp fuse	Fuse panel (b)
Check engine (RPO NB2)	20 amp fuse	Fuse panel (b)
Cigarette lighter	20 amp fuse	Fuse panel (d)
Cigarette lighter lamp	5 amp fuse	Fuse panel (a)
Clock	20 amp fuse	Fuse panel (d)
Courtesy lamps	20 amp fuse	Fuse panel (d)
Deck lid release	20 amp fuse	Fuse panel (c)
Defogger, electric rear	20 amp fuse	Fuse panel (b)
Defogging unit	20 amp fuse	Fuse panel (c)
Direction signal indicator lamps	20 amp fuse	Fuse panel (e)
Dome lamp	20 amp fuse	Fuse panel (d)
Door unlock warning	25 amp fuse	Fuse panel (k)
Fuel gage	20 amp fuse	Fuse panel (c)
Generator indicator lamp	20 amp fuse	Fuse panel (b)
Glove compartment lamp	20 amp fuse	Fuse panel (d)
Headlamps	Circuit breaker	Light switch
Headlight buzzer	20 amp fuse	Fuse panel (c)
Headlamps hi-beam indicator lamp	Circuit breaker	Light switch
Heater	20 amp fuse	Fuse panel (d)
Heater controls lamp	5 amp fuse	Fuse panel (a)
Idle stop solenoid	10 amp fuse	Fuse panel (j)
Instrument cluster lamps	5 amp fuse	Fuse panel (a)
Key wiring buzzer	20 amp fuse	Fuse panel (d)
License plate lamp, rear	20 amp fuse	Fuse panel (f)
Luggage compartment lamp	20 amp fuse	Fuse panel (d)
Oil pressure warning lamp	20 amp fuse	Fuse panel (b)
Parking lamps	20 amp fuse	Fuse panel (f)
Power seats	30 amp CB	Firewall
Power windows	30 amp CB	Firewall
Radio	10 amp fuse	Fuse panel (e)
Radio lamp	5 amp fuse	Fuse panel (a)
Seat belt warning buzzer	20 amp fuse	Fuse panel (c)
Side marker lamp - front	20 amp fuse	Fuse panel (f)
Side marker lamp - rear	20 amp fuse	Fuse panel (f)
Speed cruise control	20 amp fuse	Fuse panel (c)
Stop and turn lamps	20 amp fuse	Fuse panel (g)
Tail lamps	20 amp fuse	Fuse panel (f)
Temperature warning lamp	20 amp fuse	Fuse panel (b)
Traffic hazard indicator	20 amp fuse	Fuse panel (a)
Underhood lamp	20 amp fuse	Fuse panel (d)
Windshield washer light switch	5 amp fuse	Fuse panel (a)
Windshield wiper, two-speed	25 amp fuse	Fuse panel (k)
Wiper - pulse system	10 amp fuse	Fuse panel (j)

* Letter suffix indicates same circuit

POWER TRAINS

POWER TEAM COMBINATIONS	2
POWER TEAM MULTIPLICATION FACTORS	3
ENGINE DATA AND RATINGS	4
ENGINE SPEED AND PISTON TRAVEL	5
VEHICLE PERFORMANCE FACTORS	6
PRINCIPAL COMPONENTS	7
FUEL SYSTEM	13
EXHAUST SYSTEM	14
EMISSION CONTROL EQUIPMENT	15
LUBRICATION SYSTEM	16
COOLING SYSTEM	17
ELECTRICAL SYSTEM	18
THREE-SPEED AUTOMATIC TRANSMISSION	19

POWER TEAM COMBINATIONS

ENGINE	TRANSMISSION	MODEL APPLICATION	AXLE RATIO*		RING GEAR mm (in)	I.W. CLASS kg (lbs)
			ALL STATES			
			BASE	OPTION		
3.8 Liter V-6 229 CID (LC3) Base - All exc. Calif.	3-Speed Automatic '200c'	Sport Coupe	2.41:1	-	1.91 (7.50)	1644 (3625)
3.8 Liter V-6 231 CID (LD5) @ Avail. - Calif. Only	3-Speed Automatic '350'		2.41	-		
3.8 Liter V-6 231 CID (LC8) Avail - All exc. Calif.	3-Speed Automatic '350'		2.41	-		
3.8 Liter V-6 231 CID (LC8) Avail - Calif. @ Only	3-Speed Automatic '350'		2.73	-		
4.4 Liter V-8 267 CID (L39) Avail - All exc. Calif.	3-Speed Auto. '250c' 3-Speed Auto. '350c' +		2.29	-	1701 (3750)	
5.0 Liter V-8 305 CID (LG4) Avail - All exc. Calif.	3-Speed Auto. '250c'		2.29	-		
	3-Speed Auto. '200c' + 3-Speed Automatic '350c'		-	2.73		
5.0 Liter V-8 305 CID (LG4) Avail - Calif. @ Only	3-Speed Automatic '350'	2.29	2.73			

@ - C4 System emission control.

* - Limited slip axles available optionally; same ratios available with air conditioning.

+ - Manufacturing option.

MULTIPLICATION FACTORS

ENGINE	TRANSMISSION	SELECTOR POSITION	TOTAL TORQUE MULTIPLICATION	AXLE RATIO
3.8 Liter V-6 (229 CID) LC3	3-Speed Automatic '200c'	Drive	15.52:1 - 2.41:1	2.41
		Second	15.52:1 - 3.78:1	
		Low	15.52:1 - 6.60:1	
		Reverse	11.72:1 - 4.99:1	
3.8 Liter V-6 (231 CID) LD5	3-Speed Automatic '350'	Drive	12.15:1 - 2.41:1	2.41
		Second	12.15:1 - 3.66:1	
		Low	12.15:1 - 6.07:1	
		Reverse	9.30:1 - 4.65:1	
3.8 Liter V-6 (231 CID) LC8	3-Speed Automatic '350'	Drive	12.15:1 - 2.41:1	2.41
		Second	12.15:1 - 3.66:1	
		Low	12.15:1 - 6.07:1	
		Reverse	9.30:1 - 4.65:1	
	3-Speed Automatic '350'	Drive	13.76:1 - 2.73:1	2.73
		Second	13.76:1 - 4.15:1	
		Low	13.76:1 - 6.88:1	
		Reverse	10.54:1 - 5.27:1	
4.4 Liter V-8 (267 CID) L39	3-Speed Automatic '250c'	Drive	11.54:1 - 2.29:1	2.29
		Second	11.54:1 - 3.48:1	
		Low	11.54:1 - 5.77:1	
		Reverse	8.84:1 - 4.42:1	
	3-Speed Automatic '350c'	Drive	11.54:1 - 2.29:1	2.29
		Second	11.54:1 - 3.48:1	
		Low	11.54:1 - 5.77:1	
		Reverse	8.84:1 - 4.42:1	
5.0 Liter V-8 (305 CID) LG4	3-Speed Automatic '250c'	Drive	11.54:1 - 2.29:1	2.29
		Second	11.54:1 - 3.48:1	
		Low	11.54:1 - 5.77:1	
		Reverse	8.84:1 - 4.42:1	
	3-Speed Automatic '200c'	Drive	14.73:1 - 2.29:1	2.29
		Second	14.73:1 - 3.59:1	
		Low	14.73:1 - 6.27:1	
		Reverse	11.14:1 - 4.74:1	
	3-Speed Automatic '350c'	Drive	13.76:1 - 2.73:1	2.73
		Second	13.76:1 - 4.15:1	
		Low	13.76:1 - 6.88:1	
		Reverse	10.54:1 - 5.27:1	
	3-Speed Automatic '350'	Drive	11.54:1 - 2.29:1	2.29
		Second	11.54:1 - 3.48:1	
		Low	11.54:1 - 5.77:1	
		Reverse	8.84:1 - 4.42:1	
3-Speed Automatic '350'		Drive	13.76:1 - 2.73:1	2.73
		Second	13.76:1 - 4.15:1	
		Low	13.76:1 - 6.88:1	
		Reverse	10.54:1 - 5.27:1	

ENGINE DATA AND RATINGS

GENERAL DATA

Engine Type		90° V-6 OHV			90° V-8 OHV		
Piston	Liters	3.8	3.8		4.4	5.0	
Displacement	In ³	229	231		267	305	
Availability		RPO LC3	RPO LD5	RPO LC8	RPO L39	RPO LG4	
No. of Cylinders		6			8		
Bore & Stroke	mm	95 x 88.4	96.5 x 86.4		88.9 x 88.4	95 x 88.4	
	in.	3.736 x 3.48	3.80 x 3.40		3.50 x 3.48	3.736 x 3.48	
Compression Ratio		8.6:1	8.0:1		8.3:1	8.6:1	
Taxable (SAE) HP	kW	25.0	25.9		29.2	33.3	
	hp	33.5	34.7		39.2	44.7	
Firing Order		1-6-5-4-3-2			1-8-4-3-6-5-7-2		
Idling Speed	Manual	---					
	Automatic	600/D	550/D	650/D	500/D (550)	550/D	
Compression Press. @ Crank Speed, Engine Hot	kPa						
	lb./in. ²						
Power Plant Mounting		Two front and one rear					
Measurements	Length	mm	694.4	688.3		808.7	801
		in.	27.3	27.1		31.8	31.6
	Height	mm	738.6	736.6		718.6	752
		in.	29.1	29.0		28.3	29.6
	Width	mm	720.6			807.5	725
		in.	28.4			31.8	28.5

ADVERTISED ENGINE RATING

Engine Designation		3.8 Liter V-6 (229 CID)	3.8 Liter V-6 (231 CID)		4.4 Liter V-8 (267 CID)	5.0 Liter V-8 (305 CID)	
Availability		RPO LC3	RPO LD5	RPO LC8	RPO L39	RPO LG4	
Carburetion		2-Barrel	2-Barrel	4-Barrel	2-Barrel	4-Barrel	
Net HP @ Engine RPM	Federal	kW	86 @ 4000	---	127 @ 4000	90 @ 3600	116 @ 4000
		HP	115 @ 4000	---	170 @ 4000	120 @ 3600	155 @ 4000
	California	kW	---	82 @ 3800	127 @ 4000	---	116 @ 4000
		HP	---	110 @ 3800	170 @ 4000	---	155 @ 4000
Net Torque @ Engine RPM	Federal	N-m	237 @ 2000	---	359 @ 2400	291 @ 2000	325 @ 1600
		lb./ft.	175 @ 2000	---	265 @ 2400	215 @ 2000	240 @ 1600
	California	N-m	---	258 @ 1600	359 @ 2400	---	312 @ 2400
		lb./ft.	---	190 @ 1600	265 @ 2400	---	230 @ 2400

Length - Fan clutch to rear of engine block.
 Height - Top of air cleaner to bottom of oil pan.
 Width - Exhaust manifold to air cleaner snorkel.

ENGINE SPEED AND PISTON TRAVEL

3.8 LITER V-6 ENGINE

Engine		3.8 Liter V-6			
		RPO LC3	RPO LDS	RPO LC8	
Transmission		Auto. '200c'	Automatic '350'		
Rear Axle Ratio		2.41	2.41	2.73	
Tire Size		P205/70R14			
Crankshaft Revs. per	Kilometer	1224.3	1224.3	1386.8	
	Mile	1971.4	1971.4	2233.1	
Crankshaft RPM @ 1 Kilometer/Hr & 1 Mile/Hour	Low	km/h	55.9	51.4	58.2
		mph	90.1	82.9	93.7
	Second	km/h	32.0	31.0	35.1
		mph	51.6	50.0	56.5
	Third	km/h	20.4	20.4	23.1
		mph	32.9	32.9	37.2
	Reverse	km/h	42.2	39.4	44.6
		mph	68.1	63.5	71.8
Piston Travel	Millimeter/Kilometer	710.2	694.1	786.2	
	Foot/Mile	1143.4	1117.2	1265.4	

4.4 & 5.0 LITER V-8 ENGINES

Engine		4.4 Liter V-8	5.0 Liter V-8			
		3-Speed Automatic '250c' & '350c'	3-Speed Automatic '250c'	3-Speed Automatic '350'	3-Speed Automatic '350' & '350c'	3-Speed Automatic '200c'
Transmission						
Rear Axle Ratio		2.29	2.29	2.29	2.73	2.29
Tire Size		P205/70R14				
Crankshaft Revs. per	Kilometers	1163.3		1386.8	1163.3	
	Mile	1873.2		2233.1	1873.2	
Crankshaft RPM @ 1 Kilometer/Hour & 1 Mile/Hour	Low	km/h	48.9	58.2	53.2	
		mph	78.6	93.7	85.5	
	Second	km/h	29.5	35.1	30.5	
		mph	47.4	56.5	49.0	
	Third	km/h	19.4	23.1	19.4	
		mph	31.2	37.2	31.2	
	Reverse	km/h	37.4	44.6	40.2	
		mph	60.2	71.8	64.6	
Piston Travel	Millimeter/Kilometer	674.8		804.4	674.8	
	Foot/Mile	1086.5		1295.2	1086.5	

VEHICLE PERFORMANCE FACTORS

Engine	3.8 Liter V-6 (229 CID) 86 kW 115 HP	3.8 Liter V-6 (231 CID) 82 kW 110 HP	3.8 Liter V-6 (231 CID) 127 kW 170 HP	4.4 Liter V-8 (267 CID) 90 kW 120 HP	5.0 Liter V-8 (305 CID) 116 kW 155 HP
Model	1AZ37				

3-SPEED AUTOMATIC TRANSMISSION

Performance	Mass-Kilograms	1722	1717	1747	1774	1778
	Weight-Pounds	3797	3786	3852	3911	3920
Kilograms per Net Kilowatt	Federal	20.02	---	13.76	19.71	15.33
	California	---	20.94	13.76	---	15.33
Pounds per Net Horsepower	Federal	33.02	---	22.66	32.59	25.29
	California	---	34.41	22.66	---	25.29
Kilograms per Liter Displacement		453.2	451.8	459.7	403.2	355.6
Pounds per Cu. In. Displacement		16.6	16.39	16.67	14.65	12.85
Net Kilowatt/Liter Displacement	Federal	22.63	---	33.42	20.45	23.20
	California	---	21.58	33.42	---	23.20
Net H.P./Cu. In. Displacement	Federal	0.502	---	0.736	0.449	0.508
	California	---	0.476	0.736	---	0.508
Power Displacement	Liter/Kilometer	82.20	82.20	82.20	90.4	102.8
	Cu. Ft./Ton Mile	130.6	131.8	131.8	144.7	165.3
Displacement Factor	Liter/Tonne Kilometer	43.31	43.42	42.68	46.22	52.45
	Cu. Ft./Ton Mile	68.79	69.62	68.43	73.98	84.34

GLOSSARY (English equivalent is bracketed)

Performance Weight (Mass)	Curb Weight (Mass) plus average weight of four passengers -- 272.2 kg (600 lbs.)
Power Displacement	$\frac{\text{Crankshaft Revs/km (Revs/Mi)} \times \text{Piston Displacement}}{2 \times 28.3 \text{ Cu. Liters (2} \times 1728 \text{ cu. in.)}}$
Displacement Factor	$\frac{\text{Power Displacement}}{\text{Performance Weight (tons) Mass (tonne)}}$

PRINCIPAL COMPONENTS

CYLINDER BLOCK

Material	Cast alloy iron
Bore Diameter - mm (in.)	
3.8 Liter (229) V-6	94.822-94.958 (3.7355-3.7385)
3.8 Liter (231) V-6	96.52 (3.800)
4.4 Liter V-8	88.887-88.964 (3.4995-3.5025)
5.0 Liter V-8	94.882-94.958 (3.7355-3.7385)
Number of Bulkheads	
3.8 Liter V-6	4
4.4, 5.0 Liter V-8	5
Bore Spacing - mm (in.) (€ to €)	
3.8 Liter (229) V-6	111.8 (4.40)
3.8 Liter (231) V-6	107.7 (4.24)
4.4, 5.0 Liter V-8	111.8 (4.40)
Bearing Caps (number, material and attachment)	
3.8 Liter V-6	4, cast iron, 2-bolt
4.4, 5.0 Liter V-8	5, cast iron, 2-bolt
Water Jacket	Full length around each cylinder

CYLINDER HEAD

Material	Cast alloy iron
Bolt No. and Size	
3.8 Liter V-6	16; 11 mm (.4375 in.) dia., 14 threads/25 mm (1.0 in.)
4.4, 5.0 Liter V-8	34; 11 mm (.4375 in.) dia., 14 threads/25 mm (1.0 in.)

COMBUSTION CHAMBER VOLUME

(Total chamber volume of assembled engine with piston at top center) cm ³ (in. ³)	
3.8 Liter (229) V-6	82.15 (5.013)
3.8 Liter (231) V-6	
4.4 Liter V-8	75.05 (4.58)
5.0 Liter V-8	82.15 (5.013)

INLET MANIFOLD

Material	
3.8 Liter (229) V-6	Cast aluminum
3.8 Liter (231) V-6 (RPO LD5)	Cast iron
3.8 Liter (231) V-6 (RPO LC8)	Cast aluminum
4.4, 5.0 Liter V-8	Cast aluminum

EXHAUST MANIFOLD

Material	Cast nodular iron
Type	
3.8 Liter V-6	Dual, 3-port rear takedown
4.4, 5.0 Liter V-8	Dual, 4-port rear takedown

OUTLET DIAMETER (Nominal) - mm (in.)

3.8 Liter (229) V-6	Left - 46.7 (1.84) Right - 47.7 (1.88)
3.8 Liter (231) V-6	44.5 (1.75)
4.4, 5.0 Liter V-8	50.8 (2.0)

CRANKSHAFT

Material	Cast nodular iron
End Play - mm (in.)	
3.8 Liter (229) V-6	0.051-0.152 (.002-.006)
3.8 Liter (231) V-6	0.08-.23 (.003-.009)
4.4, 5.7 Liter V-8	0.051-0.178 (.002-.007)
Counterweights	
3.8 Liter V-6	6
4.4, 5.0 Liter V-8	6
Crank Arm Length - mm (in.)	
3.8 Liter (229) V-6	44.2 (1.74)
3.8 Liter (231) V-6	49.8 (1.96)
4.4, 5.0 Liter V-8	44.2 (1.74)
Torsional Damper	Rubber mounted inertia
Timing Gear	
3.8 Liter (229) V-6	Steel; sprocket and chain
3.8 Liter (231) V-6	Sintered iron; sprocket and chain
Pulley P.D. - mm (in.)	168.7 (6.64)

MAIN BEARINGS

Material	
3.8 Liter (229) V-6	No. 1-G66 Conecc; No. 2, 3, 4 - M4 00
3.8 Liter (231) V-6	No. 1 upper - M400 Conecc, No. 1 lower - M100 Conecc, No. 2, 3 - M400, No. 4 - M100
4.4, 5.0 Liter V-8	No. 1 - G66 Conecc; No. 2-4 - M400; No. 5 upper - M100; No. 5 lower - M400
Type	Precision, removable
Thrust Against Bearing Number	
3.8 Liter (229) V-6	4
3.8 Liter (231) V-6	2
4.4, 5.0 Liter V-8	5
Clearance - mm (in.)	
3.8 Liter (229) V-6	
No. 1, 2, 3	0.051-0.089 (.0020-.0035)
No. 4	0.013-0.038 (.0005-.0015)
3.8 Liter (231) V-6	
No. 1-4	0.010-0.040 (.0004-.0017)
4.4 Liter V-8	
No. 1-5	0.051-0.089 (.0020-.0035)
5.0 Liter V-8	
No. 1	0.020-0.051 (.0008-.0020)
No. 2-4	0.028-0.058 (.0011-.0023)
No. 5	0.043-0.081 (.0017-.0032)

DIMENSIONS

	Theoretical Inner Dia.		Effective Length		Projected Area	
	mm	in.	mm	in.	cm ²	in. ²
3.8 Liter (229) V-6						
No. 1	62.202	2.4489	20.37	.802	12.668	1.964
No. 2-3	62.194	2.4486	20.37	.802	12.668	1.964
No. 4	62.189	2.4484	38.194	1.533	24.207	3.753
3.8 Liter (231) V-6						
No. 1,3,4	63.487	2.4995	21.95	.864	13.932	2.160
No. 2	63.487	2.4995	26.85	1.057	17.041	2.642
4.4, 5.0 Liter V-8						
No. 1	62.202	2.4489	20.37	.802	12.668	1.964
No. 2-4	62.194	2.4486	20.37	.802	12.668	1.964
No. 5	62.189	2.4484	38.194	1.533	24.207	3.753

PRINCIPAL COMPONENTS

4.4 & 5.0 LITER V-8 ENGINE

CRANKSHAFT AND BEARINGS

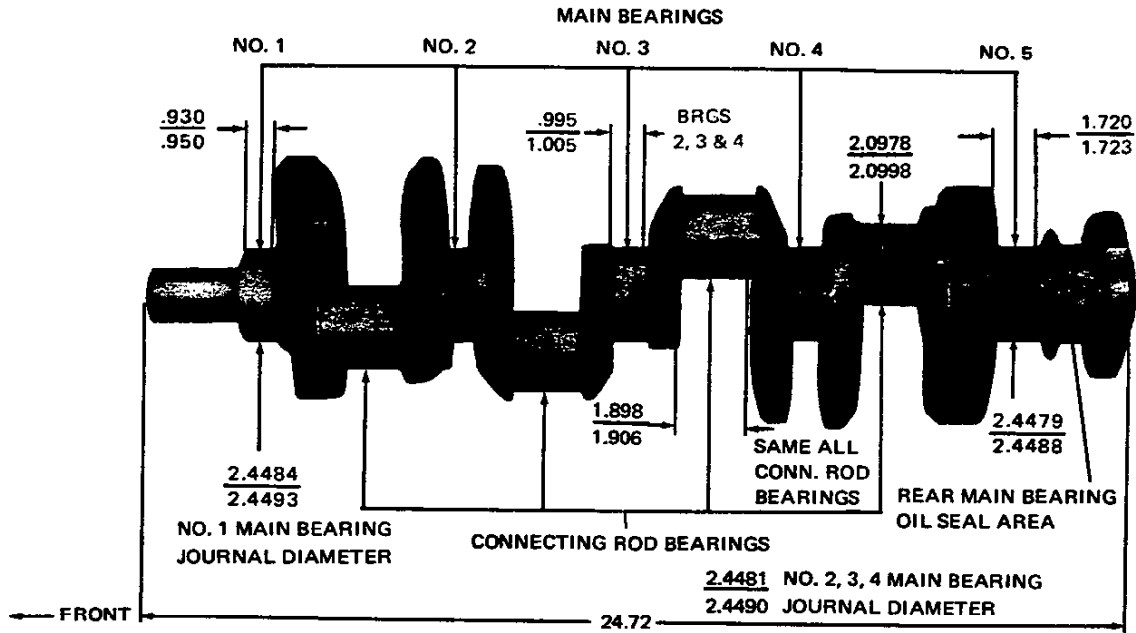

PRINCIPAL COMPONENTS

CAMSHAFT

Material	Cast alloy iron
Drive	
3.8 Liter (229) V-6	Sprocket and chain; cast iron
3.8 Liter (231) V-6	Sprocket and chain; aluminum-nylon
4.4, 5.0 Liter V-8	Sprocket and chain; aluminum-nylon

Lobe Lift - mm (in.)	Exhaust	Intake
3.8 Liter (229) V-6	6.050 (.2382)	6.600 (.2600)
3.8 Liter (231) V-6	6.368 (.2507)	6.104 (.2403)
4.4 Liter V-8	6.309 (.2484)	6.942 (.2733)
5.0 Liter V-8	6.309 (.2484)	6.774 (.2677)

Camshaft Bearing Material Steel backed babbitt

Timing Chain

Number of Links	
3.8 Liter (229) V-6	46
3.8 Liter (231) V-6	54
4.4, 5.0 Liter V-8	46
Width - mm (in.)	
3.8 Liter (229) V-6	15.87 (.625)
3.8 Liter (231) V-6	22.23 (.875)
4.4, 5.0 Liter V-8	15.87 (.625)
Pitch - mm (in.)	
3.8 Liter (229) V-6	12.7 (.500)
3.8 Liter (231) V-6	9.53 (.375)
4.4, 5.0 Liter V-8	12.7 (.500)

VALVE TRAIN

Type	Individually mounted, overhead rocker arms, push rod actuated
Lifters	Hydraulic
Push Rods	
Type	Hollow steel
Ends	Hardened
Diameter - mm (in.)	7.9 (.3125)
Length - mm (in.)	
3.8 Liter (229) V-6	196.2 (7.724)
3.8 Liter (231) V-6	220.9 (8.697)
4.4, 5.0 Liter V-8	196.2 (7.724)
Rocker Arms	
Material	Stamped steel
Ratio	
3.8 Liter (229) V-6	1.50:1
3.8 Liter (231) V-6	1.55:1
4.4, 5.0 Liter V-8	1.50:1
Rotators	
3.8 Liter (229) V-6	Exhaust
3.8 Liter (231) V-6	None
4.4, 5.0 Liter V-8	Exhaust

VALVE SPRINGS

Diameter - I.D. - mm (in.)	
3.8 Liter (229) V-6	22.05-22.45 (.868-.884)
3.8 Liter (231) V-6	22.15-22.56 (.872-.888)
4.4, 5.0 Liter V-8	22.05-22.45 (.868-.884)
Installed Length - N/mm (lb./in.)	
3.8 Liter (229) V-6	
Valve closed	
Inlet & Exhaust	356 @ 43 (80 @ 1.70)
Valve opened	
Inlet	800 @ 32 (180 @ 1.25)
Exhaust	845 @ 32 (190 @ 1.25)
3.8 Liter (231) V-6	
Valve closed	285 @ 44 (64 @ 1.73)
Valve opened	810 @ 34 (182 @ 1.34)
4.4, 5.0 Liter V-8	
Valve closed	356 @ 43 (80 @ 1.25)
Valve opened	
Inlet	778 @ 43 (175 @ 1.70)
Exhaust	819 @ 32 (184 @ 1.25)
Free Length - mm (in.)	51.6 (2.03)
Valve Spring Damper	Flat steel, 4 coils

PRINCIPAL COMPONENTS

INLET VALVES

Material	
3.8 Liter (229) V-6	SAE 1541 or 1547 steel
3.8 Liter (231) V-6	1541 steel
4.4 Liter V-8	SAE 1541-H steel
5.0 Liter V-8	21-2N steel
Coating	None
Stems	Chrome flash

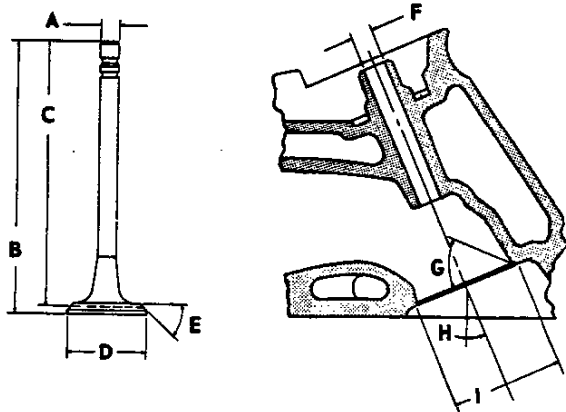

A - Stem Diameter - mm (in.)	
3.8 Liter (229) V-6	8.661-8.679 (.3410-.3417)
3.8 Liter (231) V-6	8.641-8.666 (.3402-.3410)
4.4, 5.0 Liter V-8	8.661-8.679 (.3410-.3417)
B - Overall Length - mm (in.)	
3.8 Liter (229) V-6	124.52-125.02 (4.9024-4.9224)
3.8 Liter (231) V-6	119.33-120.09 (4.698-4.728)
4.4, 5.0 Liter V-8	124.52-125.02 (4.9024-4.9224)
C - Gage Length - mm (in.)	
3.8 Liter (229) V-6	121.539-121.793 (4.7854-4.7954)
3.8 Liter (231) V-6	116.21-116.59 (4.575-4.590)
4.4, 5.0 Liter V-8	121.539-121.793 (4.7854-4.7954)
D - Overall Head Diameter - mm (in.)	
3.8 Liter (229) V-6	46.61-46.86 (1.835-1.845)
3.8 Liter (231) V-6	43.43 (1.710)
4.4 Liter V-8	43.7 (1.72)
5.0 Liter V-8	46.61-46.86 (1.835-1.845)
E - Angle at Face (°)	45
F - Guide Dia. - mm (in.)	8.70-8.73 (.3427-.3437)
G - Angle of Seat (°)	
3.8 Liter (229) V-6	46
3.8 Liter (231) V-6	45
4.4, 5.0 Liter V-8	46
H - Valve Angle (°)	
3.8 Liter (229) V-6	23
3.8 Liter (231) V-6	
4.4, 5.0 Liter V-8	23
I - Valve Seat (Cutter) Dia. - mm (in.)	
3.8 Liter (229) V-6	46.7 (1.84)
3.8 Liter (231) V-6	
4.4 Liter V-8	46.7 (1.84)
5.0 Liter V-8	46.30-46.46 (1.823-1.829)

EXHAUST VALVES

Material	21-2N steel
Coating	
3.8 Liter (229) V-6	Plain head and seat
3.8 Liter (231) V-6	Nickel plated face
4.4, 5.0 Liter V-8	Aluminized head
Stems	Chrome flash

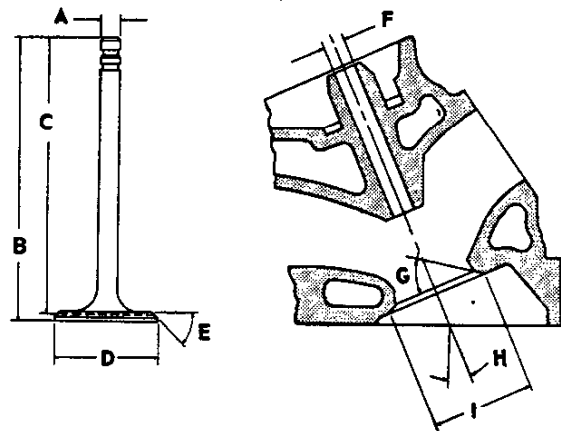

A - Stem Diameter - mm (in.)	
3.8 Liter (229) V-6	8.661-8.679 (.3410-.3417)
3.8 Liter (231) V-6	8.649-8.667 (.3405-.3412)
4.4, 5.0 Liter V-8	8.661-8.679 (.3410-.3417)
B - Overall Length - mm (in.)	
3.8 Liter (229) V-6	124.71-125.22 (4.910-4.930)
3.8 Liter (231) V-6	119.46-120.22 (4.703-4.733)
4.4, 5.0 Liter V-8	124.71-125.22 (4.910-4.930)
C - Gage Length - mm (in.)	
3.8 Liter (229) V-6	121.44-121.69 (4.781-4.791)
3.8 Liter (231) V-6	116.21-116.59 (4.575-4.590)
4.4, 5.0 Liter V-8	121.44-121.69 (4.781-4.791)
D - Overall Head Dia. - mm (in.)	
3.8 Liter (229) V-6	37.97-38.23 (1.495-1.505)
3.8 Liter (231) V-6	38.1 (1.50)
5.0 Liter V-8	37.97-38.23 (1.495-1.505)*
E - Angle of Face (°)	45
F - Guide Diameter	8.70-8.73 (.3427-.3437)
G - Angle of Seat (°)	
3.8 Liter (229) V-6	46
3.8 Liter (231) V-6	45
4.4, 5.0 Liter V-8	46
H - Valve Angle (°)	
3.8 Liter (229) V-6	23
3.8 Liter (231) V-6	
4.4, 5.0 Liter V-8	23
I - Valve Seat (Cutter) Dia. - mm (in.)	
3.8 Liter (229) V-6	42.2 (1.66)
3.8 Liter (231) V-6	
4.4 Liter V-8	42.2 (1.66)
5.0 Liter V-8	33.6 (1.324)

* - 4.4 Liter V-8, 35.1 (1.38)

PRINCIPAL COMPONENTS

VALVE LIFT - mm (in.)

3.8 Liter (229) V-6	
Inlet	9.5 (.373)
Exhaust	10.4 (.410)
3.8 Liter (231) V-6 (RPO LD5)	
Inlet	9.07 (.357)
Exhaust	9.30 (.366)
3.8 Liter (231) V-6 (RPO LC8)	
Inlet	8.66 (.341)
Exhaust	9.30 (.366)
4.4, 5.0 Liter V-8	
Inlet	9.07 (.357)
Exhaust	9.91 (.390)

VALVE TIMING (Crankshaft Degrees - Excluding Ramps)

3.8 Liter (229) V-6	
Inlet Valve	
Opens - °BTC	42
Closes - °ABC	78
Duration	300
Exhaust Valve	
Opens - °BBC	78
Closes - °ATC	52
Duration	310
3.8 Liter (231) V-6 - RPO LD5	
Inlet Valve	
Opens - °BTC	16
Closes - °ABC	63
Duration	259
Exhaust Valve	
Opens - °BBC	68
Closes - °ATC	29
Duration	277
3.8 Liter (231) V-6 - RPO LC8	
Inlet Valve	
Opens - °BTC	16
Closes - °ABC	53
Duration	249
Exhaust valve	
Opens - °BBC	68
Closes - °ATC	29
Duration	277
4.4, 5.0 Liter V-8	
Inlet valve	
Opens - °BTC	28
Closes - °ABC	64
Duration	272
Exhaust Valve	
Opens - °BBC	78
Closes - °ATC	30
Duration	288

PISTONS

Material	Cast aluminum alloy
Head Type	
3.8 Liter (229) V-6	Sump
3.8 Liter (231) V-6	Dished
4.4, 5.0 Liter V-8	Sump
Skirt Type	
3.8 Liter (229) V-6	Closed
3.8 Liter (231) V-6 (RPO LD5)	Full skirt with transverse slot
3.8 Liter (231) V-6 (RPO LC8)	Closed
4.4, 5.0 Liter V-8	Closed
Top Land Clearance - mm (in.)	
3.8 Liter (229) V-6	0.622-0.851 (.0245-.0335)
3.8 Liter (231) V-6	1.17-1.42 (.046-.056)
4.4, 5.0 Liter V-8	0.622-0.851 (.0245-.0335)
Skirt Clearance - mm (in.)	
3.8 Liter (229) V-6	0.017-0.107 (.0007-.0042)
3.8 Liter (231) V-6	0.020-0.050 (.0008-.0020)
4.4, 5.0 Liter V-8	0.018-0.107 (.0007-.0042)
Compression Ring Groove Depth - mm (in.)	
3.8 Liter (229) V-6	4.699-4.966 (.1850-.1955)
3.8 Liter (231) V-6	
4.4 Liter V-8	4.796-4.961 (.1888-.1953)
5.0 Liter V-8	5.088-5.265 (.2003-.2073)
Oil Ring Groove Depth - mm (in.)	
3.8 Liter (229) V-6	4.953-5.220 (.1950-.2055)
3.8 Liter (231) V-6	
4.4 Liter V-8	5.329-5.494 (.2098-.2163)
5.0 Liter V-8	5.342-5.570 (.2103-.2193)
Pin Bore Offset - mm (in.)	
3.8 Liter (229) V-6	1.52 (.060)
3.8 Liter (231) V-6	0.102 (.040)
4.4, 5.0 Liter V-8	1.52 (.060)
Compression Height - mm (in.)	
3.8 Liter (229) V-6	39.62 (1.56)
3.8 Liter (231) V-6	46.4 (1.825)
4.4, 5.0 Liter V-8	39.62 (1.56)

PISTON PINS

Material	SAE-1018
Length - mm (in.)	
3.8 Liter (229) V-6	75.95-76.45 (2.990-3.010)
3.8 Liter (231) V-6	73.66 (2.90)
4.4, 5.0 Liter V-8	75.95-76.45 (2.990-3.010)
Diameter - mm (in.)	
3.8 Liter (229) V-6	23.546-23.553 (.9270-.9273)
3.8 Liter (231) V-6	23.853-23.860 (.9391-.9394)
4.4, 5.0 Liter V-8	23.546-23.553 (.9270-.9273)
Clearance in Piston - mm (in.)	
3.8 Liter (229) V-6	0.0013-0.0075 (.00005-.00030)
3.8 Liter (231) V-6	0.010-0.018 (.0004-.0007)
4.4 Liter V-8	0.0013-0.0075 (.00005-.00030)
5.0 Liter V-8	0.0063-0.0089 (.00025-.00035)

PRINCIPAL COMPONENTS

COMPRESSION RING – UPPER

Material	Cast alloy iron
Type	Straight edge inside of ring
Face	
3.8 Liter (229) V-6	Barrel
3.8 Liter (231) V-6	Barrel
4.4, 5.0 Liter V-8	Radius
Coating	
3.8 Liter V-6	Molybdenum filled channel
4.4, 5.0 Liter V-8	0.0102 (.0004) chrome flash
Width – mm (in.)	
3.8 Liter (229) V-6	1.96-1.98 (.0770-.0780)
3.8 Liter (231) V-6	1.96-1.98 (.0770-.0780)
4.4, 5.0 Liter V-8	1.96-1.98 (.0770-.0780)
Wall Thickness – mm (in.)	
3.8 Liter (229) V-6	4.24-4.50 (.167-.177)
3.8 Liter (231) V-6	4.27-4.52 (.168-.178)
4.4, 5.0 Liter V-8	4.24-4.50 (.167-.177)
Gap – mm (in.)	
3.8 Liter (229) V-6	0.25-0.51 (.010-.020)
3.8 Liter (231) V-6	0.33-0.58 (.013-.023)
4.4, 5.0 Liter V-8	0.25-.051 (.010-.020)

COMPRESSION RING – LOWER

Material	Cast alloy iron
Face	
3.8 Liter (229) V-6	Reverse tapered
3.8 Liter (231) V-6	Reverse tapered
4.4, 5.0 Liter V-8	Tapered
Type	
3.8 Liter (229) V-6	Inside bevel
3.8 Liter (231) V-6	Inside bevel
4.4, 5.0 Liter V-8	Reverse twist
Coating	
3.8 Liter (229) V-6	Phosphate
3.8 Liter (231) V-6 (RPO LD5)	Phosphate
3.8 Liter (231) V-6 (RPO LC8)	Lubrited
4.4, 5.0 Liter V-8	Lubrited
Width – mm (in.)	
3.8 Liter (229) V-6	1.956-1.981 (.0770-.0780)
3.8 Liter (231) V-6	1.956-1.981 (.0770-.0780)
4.4, 5.0 Liter V-8	1.956-1.981 (.0770-.0780)
Wall Thickness – mm (in.)	
3.8 Liter (229) V-6	4.24-4.50 (.167-.177)
3.8 Liter (231) V-6	4.27-4.52 (.168-.178)
4.4, 5.0 Liter V-8	4.24-4.50 (.167-.177)
Gap – mm (in.)	
3.8 Liter (229) V-6	0.25-0.64 (.010-.025)
3.8 Liter (231) V-6	0.33-0.58 (.013-.023)
4.4, 5.0 Liter V-8	0.25-0.64 (.010-.025)

OIL CONTROL RING

Type	Multi-piece (two rails and one spacer)
Material	
Rails	Steel
Spacer	Stainless steel
Coating	Chrome plated
Width (Assembled) – mm (in.)	
3.8 Liter (229) V-6	4.52-4.62 (.178-.182)
3.8 Liter (231) V-6	3.43-3.51 (.135-.142)
4.4, 5.0 Liter V-8	4.52-4.62 (.178-.182)
Wall Thickness – mm (in.)	
3.8 Liter (229) V-6	3.51-3.66 (.138-.144)
3.8 Liter (231) V-6	3.76-3.86 (.148-.152)
4.4, 5.0 Liter V-8	3.51-3.66 (.138-.144)
Gap – mm (in.)	
3.8 Liter (229) V-6	2.25-0.89 (.010-.035)
3.8 Liter (231) V-6	0.38-0.89 (.015-.035)
4.4, 5.0 Liter V-8	0.25-.089 (.010-.035)

CONNECTING ROD BEARINGS

Type	Precision, removable
Material	Premium aluminum
Clearance – mm (in.)	
3.8 Liter (229) V-6	0.025-0.063 (.0010-.0025)
3.8 Liter (231) V-6	0.013-0.066 (.0005-.0026)
4.4, 5.0 Liter V-8	0.033-0.089 (.0013-.0035)
Effective Length – mm (in.)	
3.8 Liter (229) V-6	16.97 (.668)
3.8 Liter (231) V-6	16.61 (.654)
4.4, 5.0 Liter V-8	20.24 (.797)
End Play – mm (in.)	
3.8 Liter (229) V-6	0.15-0.38 (.006-.015)
3.8 Liter (231) V-6	0.15-0.58 (.006-.023)
4.4, 5.0 Liter V-8	0.15-0.41 (.006-.016)

FUEL TANK

Capacity - L (gals.)	68.5 (18.1) approximately
Location	Under floor
Filler Location	Rear center behind hinged rear license plate

FUEL FILTERS, DUAL

In Fuel Tank	Fine mesh plastic strainer
In Carburetor Inlet	Paper filter element

FUEL PUMP

Type	Mechanical, diaphragm
Drive	Camshaft eccentric
Location on Engine	
3.8 Liter (229) V-6	Lower RF
3.8 Liter (231) V-6	Lower LF
4.4, 5.0 Liter V-8	Lower RF
Pressure Range - kPa (psi)	
3.8 Liter (229) V-6	31-41 (4.5-6.0)
3.8 Liter (231) V-6	29-40 (4.25-5.75)
4.4, 5.0 Liter V-8	52-62 (7.5-9.0)

AIR CLEANER

Type	Replaceable paper element, single snorkel
Diameter - mm (in.)	
3.8 Liter (229) V-6	304.8 (12.0)
3.8 Liter (231) V-6 (RPO LD5)	304.8 (12.0)
3.8 Liter (231) V-6 (RPO LC8)	Remote
4.4 Liter V-8	304.8 (12.0)
5.0 Liter V-8	374.7 (14.75)

CARBURETORS

Make	Rochester Products
Type	
3.8 Liter (229) V-6	Dualjet 2-barrel
3.8 Liter (231) V-6 (RPO LD5)	Dualjet 2-barrel
3.8 Liter (231) V-6 (RPO LC8)	Turbocharged 4-barrel
4.4 Liter V-8	Dualjet 2-barrel
5.0 Liter V-8	Quadrajets 4-barrel
SAE Flange Size - mm (in.)	38.1 (1.50)
Throttle Bore - mm (in.)	
3.8 Liter (229) V-6	35.1 (1.38)
3.8 Liter (231) V-6 (RPO LD5)	36.5 (1.4375)
3.8 Liter (231) V-6 (RPO LC8)	
Primary	34.9 (1.375)
Secondary	57.2 (2.25)
4.4 Liter V-8	35.1 (1.38)
5.0 Liter V08	
Primary	35.1 (1.38)
Secondary	57.2 (2.25)
Secondary Throttle Actuation	By linkage, approximately when primary valves are opened halfway between opened and closed
Venturi Diameter - mm (in.)	
3.8 Liter (229) V-6	30.9 (1.218)
3.8 Liter (231) V-6 (RPO LD5)	27.8 (1.093)
3.8 Liter (231) V-6 (RPO LC8)	
Primary	
Secondary	
4.4 Liter V-8	30.9 (1.218)
5.0 Liter V-8	
Primary	27.7 (1.09)
Secondary	Air valve

CHOKE

Type	Electric
------	----------

EXHAUST SYSTEMS

TYPE Single exhaust and converter
with crossover pipe

MUFFLER

Type Oval reverse flow
Construction Heads only body joined by
rolled lock seam
Installation Transverse mounted behind
rear axle
Head - mm (in.) . . . 1.22 (.048) aluminized sheet steel
Shell - mm (in.) . . . 0.79 (.031) aluminized sheet steel
Cover - mm (in.) . . . 0.38 (.015) aluminized sheet steel
Body - mm (in.)
Length
3.8 Liter V-6 508 (20.0)
4.4, 5.0 Liter V-8 559 (22.0)
Width 235 (9.25)
Height 127 (5.00)

EXHAUST CROSSOVER PIPE

Dimensions (O.D.) - mm (in.)
3.8 Liter V6 50.8 (2.0)
4.4, 5.0 Liter V-8 50.8 (2.0)

EXHAUST PIPE TO CONVERTER

Dimensions (O.D.) - mm (in.)
3.8 Liter (229) V-6 57.15 (2.25)
3.8 Liter (231) V-6 (LD5) 57.15 (2.25)
3.8 Liter (231) V-6 (LC8) 63.5 (2.50)
4.4, 5.0 Liter V-8 63.5 (2.50)

EXHAUST PIPE - CONVERTER TO MUFFLER

Dimensions (O.D.) - mm (in.)
3.8 Liter (229) V-6 50.8 (2.0)
3.8 Liter (231) V-6 (LD5) 50.8 (2.0)
3.8 Liter (231) V-6 (LC8) 57.15 (2.25)
4.4 Liter V-8 50.8 (2.0)
5.0 Liter V-8 57.15 (2.25)

TAIL PIPE

Dimensions (O.D.) - mm (in.)
3.8 Liter (229) V-6 50.8 (2.0)
3.8 Liter (231) V-6 (RPO LD5) 50.8 (2.0)
3.8 Liter (231) V-6 (RPO LC8) 57.15 (2.25)
4.4 Liter V-8 50.8 (2.0)
5.0 Liter V-8 57.15 (2.25)

CATALYTIC CONVERTER

Location Under floor
Size - Liter (cu. in.)
3.8 Liter (229) V-6 2.6 (160)
3.8 Liter (231) V-6 (RPO LD5) 4.3 (260)
3.8 Liter (231) V-6 (RPO LC8)
49 States exc. Calif. 4.3 (260)
Calif. only 2.8 (170)
4.4, 5.0 Liter V-8 4.3 (260)
Substrate Material Bead *
Type
3.8 Liter (229) V-6 Oxidizing
3.8 Liter (231) V-6 (RPO LD5) Oxidizing
and reducing
3.8 Liter (231) V-6 (RPO LC8)
Federal Oxidizing
California Dual bed
4.4 Liter V-8 Oxidizing
5.0 Liter V-8
Federal Oxidizing
California Oxidizing and reducing

*Monolith for 3.8 Liter (231) V-6 (RPO LC8).

EMISSION CONTROL EQUIPMENT

SYSTEM APPLICATION

SYSTEM TYPE	ENGINE ADAPTATION						
	3.8 Liter V-6				4.4L V-8	5.0 Liter V-8	
	229		231		267	305	
	2-Barrel		4-Bbl. Turbocharged		2-Barrel	4-Barrel	
	Fed.	Calif.	Fed.	Calif.	Fed.	Fed.	Calif.
AIR - Air Injection Reactor	X	X	X	X	X	X	X
CHA - Carburetor Hot Air	X	X	X	X	X	X	X
EFE - Early Fuel Evaporation	X	X	X	X	X	X	X
P-EGR - Exhaust Pressure Modulated EGR	X	X	X	X	X	X	X
UFC - Underfloor Converter	X	-	X	-	X	X	-
C-4 - Computer Controlled Catalytic Converter	-	X	-	X	-	-	X
EST - Electronic Spark Timing	-	X	-	X	-	-	-
ESC - Electronic Spark Control	-	-	X	-	-	-	-
FEC - Fuel Evaporation Control	X	X	X	X	X	X	X
PCV - Positive Crankcase Ventilation	X	X	X	X	X	X	X

BASIC FUNCTION OF SYSTEMS

AIR INJECTION REACTOR

Compresses, regulates and distributes quantities of air to the manifold to more completely burn carbon monoxide and hydrocarbon emissions.

CARBURETOR HOT AIR

A thermostatically controlled air induction system designed to aid carburetion. Consists of a heat stove to supply preheated air and a vacuum powered damper to mix air normally drawn in through the snorkel with the hot air. Produces a more uniform carburetor air temperature which permits proper emission control with improved engine operation.

EARLY FUEL EVAPORATION

A thermostatically controlled system designed to supply hot exhaust gases to heat carburetor base and inlet manifold during early stages of cold engine operation. Improves cold engine driveability during warm-up.

EXHAUST PRESSURE MODULATED EGR

Meters exhaust gas into induction system for recirculation throughout the combustion cycle to reduce oxides of nitrogen emissions. Exhaust pressure modulation in addition to vacuum modulation to increase control parameters.

UNDER FLOOR CONVERTER

A device placed in the exhaust system containing the catalytic bed through which exhaust gasses are passed. The catalyst may be configured to cause both a reduction and oxydation reaction, or an oxydation reaction only.

COMPUTER CONTROLLED CATALYTIC CONVERTER SYSTEM

A system designed to monitor engine functions and through an on-board computer, combine precise electronic control of fuel-air ratio near the stoichiometric with an oxidation-reduction catalytic converter to control emissions. This system maintains the currently achieved low levels of hydrocarbons and carbon monoxide emissions while significantly lowering oxides of nitrogen.

ELECTRONIC SPARK TIMING

Conventional vacuum and centrifugal advance mechanisms replaced by electronic components to optimize spark timing for better exhaust emissions control and fuel economy.

ELECTRONIC SPARK CONTROL

A system which detects engine knock and retards distributor spark timing sufficiently to eliminate harmful detonation.

FUEL EVAPORATION CONTROL

Controls emission of gasoline vapors to the atmosphere by means of an integral separator with the fuel tank that separates vapor from liquid fuel - a filler cap that doesn't permit venting into the atmosphere - a canister for storage of vapors - lines, hoses and valves to control and transport vapors from fuel tank and carburetor float bowl to storage, and finally, to the carburetor for utilization in running the engine.

POSITIVE CRANKCASE VENTILATION

Withdraws oil and gas vapors from the various cavities, throughout the engine for burning in the combustion cycle.

LUBRICATION SYSTEM

GENERAL

Type	Controlled, full pressure
Main Bearing	Pressure
Connecting Rods	Pressure
Piston Pins	Splash
Camshaft Bearings	Pressure
Tappets	Pressure
Timing Gears	
3.8 Liter V-6	Splash & nozzle
4.4 Liter V-8	Splash & nozzle
5.0 Liter V-8	Centrifugally oiled from camshaft bearings
Oil Pressure Sending Unit	Electric
Oil Filler Cap	
Type	Positive seal
Location	Left valve rocker cover

OIL PAN CAPACITIES

Refill – Liters (quarts)	3.78 (4.0)
Refill with Filter Change – L (qts)	
3.8 Liter V-6	4.07 (4.31)
4.4, 5.0 Liter V-8	4.39 (4.625)

LUBRICANT GRADES AND TEMPERATURES

-6.6°C (20°F) & above	10W-30, 10W-40, 20W-20, 20W-40, 20W-50
-17.7°C (°F) to +15.5°C (60°F)	10W, 5W-30, 10W-30, 10W-40
-6.6°C (20°F) and below	5W-20, 10W-30

OIL PUMP

Type	Gear
Regulator Valve	Opens between 276-310 kPa (40-45 psi)
Oil Pressure – kPa (psi) @ Engine RPM	
3.8 Liter (229) V-6	310 (45) @ 2000
3.8 Liter (231) V-6	235 (34) @ 2400
4.4, 5.0 Liter V-8	310 (45) @ 2000
Intake, Type	Stationary, fixed pickup with screen

OIL FILTER

Type	Full flow throwaway canister
Location	
3.8 Liter (229) V-6	Left rear side of engine
3.8 Liter (231) V-6	Right front side of engine
4.4, 5.0 Liter V-8	Left rear side of engine
Capacity – Liters (quarts)	
3.8 Liter V-6	0.29 (0.31)
4.4, 5.0 Liter V-8	0.59 (0.625)
By-Pass Valve – kPa (psi)	
3.8 Liter (229) V-6	Opens between 62-76 (9-11) drop in pressure
3.8 Liter (231) V-6	Opens between 69-83
4.4, 5.0 Liter V-8	(10-12) drop in pressure

OIL DIPSTICK LOCATION

3.8 Liter (229) V-6	Right side, center of block
3.8 Liter (231) V-6	Left side, center of block
4.4, 5.0 Liter V-8	Right side, center of block

OIL PAN DRAIN PLUG

Type	Hex head
Location	
3.8 Liter (229) V-6	Left lower face of oil pan sump
3.8 Liter (231) V-6	Lower face of oil pan sump
4.4, 5.0 Liter V-8	Left lower face of oil pan sump
Hex Head Size – mm (in)	21.84-22.23 (.860-.875)
Thread Size	1/2-20 UNF 2A
Length – mm (in)	20.6 (0.81)

COOLING SYSTEM

GENERAL

Type	Pressure vented through coolant recovery system
Capacity with Heater – Liters (Quarts)	
3.8 Liter (229) V-6	17.67 (18.67)
3.8 Liter (231) V-6	14.59 (15.42)
4.4 Liter V-8	20.70 (21.87)
5.0 Liter V-8	18.52 (19.57)

RADIATOR

Type	Cross flow, tube and center
Core Constant and Thickness	
Distance between fins – mm (in)	
3.8 Liter (229) V-6	7.6 (.30)
3.8 Liter (231) V-6 (RPO LD5)	7.6 (.30)
3.8 Liter (231) V-6 (RPO LC8)	
Federal	5.6 (.22)
California	5.1 (.20)
4.4 Liter V-8	5.0 (.20)
5.0 Liter V-8	
Federal	5.1 (.20)
California	4.0 (.16)
Distance between tubes – mm (in)	13.97 (.55)
Core Thickness – mm (in)	
3.8 Liter V-6	31.5 (1.24)
4.4 Liter V-8	25.0 (0.98)
5.0 Liter V-8	
Federal	31.5 (1.24)
California	25.0 (0.98)
Frontal Area - cm ² (in ²)	
3.8 Liter V-6	2278 (353)
4.4 Liter V-8	2865 (444)
5.0 Liter V-8	
Federal	2878 (446)
California	2865 (444)
Overflow	Separate coolant bottle

RADIATOR, H.D. (RPO V08)

Constant Core & Thickness	
Distance between fins - mm (in)	
3.8 Liter (229) V-6	5.6 (.22)
3.8 Liter (231) V-6 (RPO LD5)	5.1 (.20)
3.8 Liter (231) V-6 (RPO LC8)	3.6 (.14)
4.4 Liter V-8	5.1 (.20)
5.0 Liter V-8	
Federal	3.5 (.14)
California	3.0 (.12)
Distance between tubes - mm (in)	13.97 (.55)
Core Thickness - mm (in)	
3.8 Liter (229) V-6	31.5 (1.24)
3.8 Liter (231) V-6 (RPO LD5)	31.5 (1.24)
3.8 Liter (231) V-6 (RPO LC8) Calif.	49.8 (1.96)
4.4 Liter V-8	31.5 (1.24)
5.0 Liter V-8	25 (0.98)
Frontal Area - cm ² (in ²)	
3.8 Liter V-6	2278 (353)
4.4 Liter V-8	2878 (446)
5.0 Liter V-8	2865 (444)
Overflow	Separate coolant bottle

RADIATOR CAP RELIEF VALVE

Opens at kPa (psi)	103.4 (15)
--------------------	------------

THERMOSTAT

Type	Pellet
Begins to Open -°C (°F)	90.6 (195)
Fully Open at -°C (°F)	108 (227)

RADIATOR HOSE

Outlet, Lower (Radiator to Water Pump)	
Number and type	One, molded
Inner diameter - mm (in)	38.1 (1.50)
Inlet, Upper (Thermostat Hsg. to Radiator)	
Number and type	One, molded
Inner diameter - mm (in)	38.1 (1.50)

FAN

Number of Blades	4, staggered
Diameter - mm (in)	483 (19.0)
Fan Pulley P.D. - mm (in)	178 (7.0)

BELT – CRANKSHAFT, FAN & ALTERNATOR

Number Used	One
Angle of 'V' (°)	34-38
Pitch Line - mm (in)	
3.8 Liter (229) V-6	1130 (44.5)
3.8 Liter (231) V-6	1105 (43.5)
4.4, 5.0 Liter V-8	
Federal	1130 (44.5)
California	1194 (47.0)
Width - mm (in)	9.65 (.380)

WATER PUMP

Type	Centrifugal
Bearing Type	Permanently lubricated double row ball
Drive	Fan belt
Ratio (pump to engine RPM)	0.949:1

DRAIN LOCATIONS

Engine Block	
Type	Plug
Location	Right and left center
Radiator	
Type	Petcock
Location	Bottom face, right side

ELECTRICAL SYSTEM

SUPPLY SYSTEM

BATTERY

Type 'Freedom'
 Voltage Rating & Watts
 3.8 Liter V-6 12-2500
 4.4, 5.0 Liter V-8 12-3200
 Cold Cranking Capacity
 3.8 Liter V-6 60 min. res. capacity
 4.4, 5.0 Liter V-8 80 min. res. capacity
 Terminal Grounded Negative
 Location Right front side of engine compartment

ALTERNATOR

Type Diode rectified
 Rating - Ampere
 3.8 Liter (229) V-6 37
 3.8 Liter (231) V-6 (RPO LD5) 42
 3.8 Liter (231) V-6 (RPO LC8) 55
 4.4, 5.0 Liter V-8 37
 Volts 12-15
 Driven By Fan belt
 Pulley P.D. - mm (in)
 3.8 Liter (229) V-6 61.7 (2.43)
 3.8 Liter (231) V-6 71.5 (2.81)
 4.4, 5.0 Liter V-8 61.7 (2.43)
 Ratio (Alternator to engine RPM)
 3.8 Liter (229) V-6 2.73:1
 3.8 Liter (231) V-6 2.36:1
 4.4, 5.0 Liter V-8 2.73:1

REGULATOR

Type Micro circuit unit, integral with alternator
 Voltage 13.8-14.8

IGNITION SYSTEM

Type High Energy Ignition (H.E.I.)
 Distributors Refer to chart below

COIL

Type Integral with distributor cap

SPARK PLUGS

Type
 3.8 Liter V-6 R45TS
 4.4 Liter V-8 R45TS
 5.0 Liter V-8 R43TS
 Thread Size - mm 14
 Gap - mm (in)
 3.8 Liter V-6 1.14 (.045)
 4.4, 5.0 Liter V-8 1.14 (.045)
 Torque - N·m (lb. ft.) 9-20 (7-15)

CABLE Linen core impregnated with electrical conducting material and insulation of rubber with neoprene jacket

STARTING SYSTEM

Starting Motor
 Rotation (Drive end view) Clockwise
 Motor Drive
 Engagement Positive shift solenoid
 Number of Teeth
 Pinion 9
 Flywheel
 3.8 Liter (229) 153
 3.8 Liter (231) 160
 4.4, 5.0 Liter V-8 168

DISTRIBUTORS	3.8 Liter V-6				4.4 Liter V-8	5.0 Liter V-8	
	RPO LC3	RPO LD5	RPO LC8		RPO L39	RPO LG4	
Model	1110752	(1110784)	1110550	(1110784)	1103382	1103384	(1103386)
Type	High Energy Ignition (H.E.I.)						
Centrifugal Advance begins @ RPM	0 @ 1200				0 @ 1200	0 @ 800	0 @ 1000
Maximum Degrees @ RPM	14 @ 4100				22 @ 4400	20 @ 4000	20 @ 3800
Vacuum Advance begins @ kPa	0 @ 10.1				0 @ 13.5	0 @ 13.5	0 @ 13.5
Maximum Degrees @ kPa	16 @ 21.9				14 @ 27.0	15 @ 40.5	16 @ 25.3
Timing (Initial Design Setting) Crankshaft Degrees @ RPM (With Vacuum Line Disconnected)	10° BTC				4° BTC	4° BTC	4° BTC
Timing Mark Location	Torsional Damper						

Data in brackets () pertains to California.

THREE-SPEED AUTOMATIC TRANSMISSIONS

Application		See Power Train Chart, Page 2		
Transmission		'350', '250c', '350c'	'200c'	
General	Type	Automatic hydraulic torque converter with compound planetary gear system - three forward speeds and reverse		
	Selector Lever	Location (a)	Steering column	
		Operation	Actuates controls by a hydraulic system from pressurized gear type pump	
		Quadrant pattern	P-R-N-D-L2-L1	
	Parking Lock	Type	Locking pawl	
		Operation	Applied by selector lever through manual linkage	
	Method of cooling	Water		
Flywheel assembly	Steel stamping with welded on ring gear			
Hydraulic System	Oil pressure pump	Supplies hydraulic pressure from an engine driven gear type pump		
	Type	Steel spool valve		
	Valves	Manual	Establishes range of transmission operation	
		Pressure regulator	Provides main line pressure	
		Shift (1-2)	Controls oil pressure for transmission shift from 1-2 to 2-1	
		Shift (2-3)	Controls oil pressure for transmission shift from 2-3 or 3-2	
	Modulator	Regulates line pressure with modulator oil pressure which varies with torque to transmission		
	Accumulator	Provides greater flexibility in attaining desired shift quality for various engine requirements		
	Pressure @ Idle (b)	Drive	60	55
		L2	87	80
L1		87	80	
Reverse		91	84	
Converter Assembly	Pump (Drive member)	Multivane type, sheet metal blade spot welded to steel pump housing that is an integral part of the converter housing		
	Turbine (Driven member)	Steel axial flow blades assembled between inner & outer steel shells		
	Stator assembly	Aluminum multivane type blades mounted on a one way (overrunning) roller clutch		
	Stall ratio	2.00	2.35	
	Stall speed (RPM)	2110		
	Diameter (nominal)	298.4 mm (11.75 in.) (c)		
Planetary Gear Set	Reaction carrier assembly	4 steel pinion gears		
	Output carrier assembly	4 steel pinion gears		
	Intermediate band	Circular steel with organic lining		
	Range	D (Drive)	2.52:1 - 1.52:1 - 1.00:1	2.74 - 1.57 - 1.00
		L2 (low two)	2.52:1 - 1.52:1	2.74 - 1.57
		L1 (Low one)	2.52:1	2.74
		R (Reverse)	1.93:1	2.07
Servo Unit	Piston with release spring and inner cushion spring			
Case	Material			
Clutches	Type	Four, multiple disk	Three, multiple disk	
	Material	Drive plates	Steel with bonded organic facings	
		Driven plates	Flat steel	
	Forward Clutch	5 each drive & driven plates	4 each drive & driven plates	
	Direct clutch	4 each drive & driven plates	3 each drive & driven plates	
	Intermediate clutch	3 each drive & driven plates	---	
	Low & Reverse Clutch	5 each drive & driven plates	4 each drive & driven plates	
Release spring	Radial row steel coil			
Torque Multiplication	Drive (maximum)	5.04:1 to 1.00	6.44:1 to 1.00	
	Low 2	5.04:1 to 1.52	6.44:1 to 1.57	
	Low 1	5.04:1 to 2.52	6.44:1 to 2.74	
	Reverse	3.86:1 to 1.93	4.86:1 to 2.07	
Governor	Type	Cross-axis centrifugal		
	Operation	Regulates a pressure proportional to car speed which acts upon the (1-2) (2-3) shift and modulator valve		
Lubricant	Type	Dexron II		
	Capacity	9.5 Litres (20)		
		Dry		
		Refill		
		3.8 Litres (8 pints)	3.3 Litres (7 pints)	

- (a) Floor mounted when console is used quadrant changes to P-R-N-3-2-1.
- (b) 600 RPM input.
- (c) 310 mm (12.2 in) with '350' automatic transmission.

VUC
gmuc
gmuc

11/11/11



**Specifications
Form
Passenger Car**

1980

METRIC (U.S. Customary)

Manufacturer CHEVROLET MOTOR DIVISION GENERAL MOTORS CORPORATION	Car Line MONTE CARLO	
Mailing Address CHEVROLET ENGINEERING CENTER 30003 VAN DYKE WARREN, MICHIGAN 48090	Model Year 1980	Issued: OCT. 1979
		Revised (*) Feb. 1980

The information contained herein is prepared, distributed by, and is solely the responsibility of the automobile manufacturing company to whose products it relates. Questions concerning these specifications should be directed to the manufacturer whose address is shown above. This specification form was developed by automobile manufacturing companies under the auspices of the Motor Vehicle Manufacturers Association of the United States, Inc.

General Specifications herein are those in effect at date of compilation and are subject to change without notice by the manufacturer.

MVMA Specifications Forms
Passenger Car
METRIC (U.S. Customary)

Table of Contents

1	Car Models
2	Power Teams
3-7	Engine
7	Exhaust System
8	Fuel System
9	Cooling System
10, 11	Vehicle Emission Control
12-14	Electrical
15-17	Drive Units
18	Tires and Wheels
18, 19	Brakes
20	Steering
21	Suspension — Front and Rear
22	Body — Miscellaneous Information
22	Frame
23	Convenience Equipment
24	Vehicle Mass (Weight)
25	Optional Equipment Mass (Weight)
26-30	Car and Body Dimensions — including Fiducial Marks, Glass, Lamps and Headlamp Shape
31-35	Car and Body Dimension Key Sheets
36	Index

NOTE:

1. This form uses both SI metric units and U.S. Customary units. The Metric unit of measurement is presented first, and the U.S. Customary unit follows in parentheses.
2. UNLESS OTHERWISE INDICATED:
 - a. Specifications apply to standard models without optional equipment. Significant deviations are noted.
 - b. Nominal design dimensions are used throughout these specifications.
 - c. All linear dimensions are in millimeters (inches), and all mass (weight) specifications are in kilograms (pounds).
3. The General Specifications herein are those in effect at date of completion and are subject to change without notice by the manufacturer.
4. A printed or computer tape supplement containing additional Car and Body Dimensions and/or drawings (based in part on SAE J1100a "Motor Vehicle Dimensions") may be available from the manufacturer.

MVMA Specifications Form
Passenger Car
METRIC (U.S. Customary)

Car Line MONTE CARLO
 Model Year 1980 Issued 10-79 Revised (*) _____

Car Models

Model Description (Include Line Drawings of Vehicles, if Desired)	Make, Car Line, Series, Body Type (Mfr's Model Code)	No. of Designated Seating Positions (Front/Rear)		Max. Trunk/Cargo Load Kilograms (Pounds)
<u>MONTE CARLO</u>	<u>MODEL NUMBER</u>	<u>FRONT</u>	<u>REAR</u>	
2-Door Sport Coupe	1AZ37	3	3	

NOTE: Any specifications on the following pages that are specific to California requirements are indicated accordingly.

MVMA Specifications Form
Passenger Car
METRIC (U.S. Customary)

Car Line MONTE CARLO
 Model Year 1980 Issued 10/79 Revised (*) _____

Power Teams (Indicate whether standard or optional)

SAE Net bhp (brake horsepower) and net torque corrected to 85° F and 29.38 in. Hg atmospheric pressure.

SERIES # AVAILABILITY	ENGINE						TRANSMISSION	AXLE RATIO (:1)	
	Displ liters (in ³)	Carb.	Comp. Ratio	SAE Net at RPM		Exhaust System*		(Std. first (Indicate A/C ratio))	
				kW (bhp)	Torque N·m (lb. ft.)			A	B
Base - All Exc. Calif. -All Models	3.8 (229) RPO LC3	2-Bb1	8.6:1	86 (115) @ 4000	237 (175) @ 2000	S	Auto '200c'-Base	2.41	-
Avail. - Calif. Only -All Models (a)	3.8 (231) RPO LD5	2-Bb1	8.0:1	82 (110) @ 3800	258 (190) @ 1600	S	Auto '350'-Base	2.41	-
Avail. - Exc. Calif. -All Models	3.8 (231) RPO LC8	4-Bb1 Turbo	8.0:1	127 (170) @ 4000	359 (265) @ 2400	S	Auto '350'-Base	2.41	-
Avail. - Calif. Only -All Models(a)				Auto '350'-Base	2.73				
Avail. - All Exc. Calif. -All Models	4.4 (267) RPO L39	2-Bb1	8.3:1	90 (120) @ 3600	291 (215) @ 2000	S	Auto '250c'-Base (Auto '350c'-Base@)	2.29	-
Avail. - All Exc. Calif. -All Models	5.0 (305) RPO LG4	4-bb1	8.6:1	116 (155) @ 4000	325 (240) @ 1600	S	Auto '250c'-Base (Auto '200c'-Base@)	2.29	-
Avail. - Calif Only (a)				Auto '350c' Base	-		2.73		
-All models				Auto '350' -Base	2.29		2.73		
# - 'Base' and 'Available' refer to engine availability. A - Base - all states. B - Optional - all states except California. Limited slip differential and Air Conditioning available with all axle ratios. (a) - C-4 system emission control. @ - Manufacturing option.									

*S - Single D - Dual

MVMA Specifications Form
Passenger Car
METRIC (U.S. Customary)

Car Line **MONTE CARLO**
 Model Year **1980** Issued **10/79** Revised (*) **2/80**

Engine Description/Carb.	3.8 Liter V-6/2-Bb1 (229 CID) RPO LC3	4.4 Liter V-8/2-Bb1 (267 CID) RPO L39	5.0 Liter V-8/4-Bb1 (305 CID) RPO LG4
--------------------------	--	--	--

Engine — General

*Total dressed engine mass (wt) dry	189 kg (416.6 lb)	245.9 kg (542.1 lb)	243.9 kg (537.7 lb)
Type (in-line, V and Angle, Flat) Location (Front, Mid, Rear)	90° 'V'		
No. of cylinders	6	8	
Bore	95 (3.736)	88.9 (3.50)	95 (3.736)
Stroke	88.4 (3.48)		
Piston Displacement cm ³ (in ³)	3753 (229)	4375 (267)	4998 (305)
Bore Spacing (C/L to C/L)	111.8 (4.40)		
Cyl. No. system (front to rear)**	L Bank	1-3-5	1-3-5-7
	R. Bank	2-4-6	2-4-6-8
Firing Order	1-6-5-4-3-2	1-8-4-3-6-5-7-2	
Cylinder Head Material	Cast Alloy Iron		
Cylinder Block Material	Cast Alloy Iron		
Cylinder block deck height	229.2 (9.025)	229.4 (9.03)	
Number of mtg. points	Front	Two	
	Rear	One	
Engine installation position (transverse, Longitudinal)	Longitudinal		
Recommended fuel Leaded, unleaded	Unleaded		
Fuel antiknock index ($\frac{R + M}{2}$)	87		
Cylinder Head Volume — cm ³	58.9	51.8	58.9
Head Gasket Thickness (Compressed)	.021		
Head Gasket Volume — cm ³	3.98	3.61	3.98
Deck clearance (minimum) (above or below block)	.025 below		
Minimum Combustion Chamber Volume — cm ³	56.7	49.6	56.7

Engine — Pistons

Material	Cast Aluminum		
Description and finish	Closed skirt, sump head		
Mass, g (weight, oz.) — Piston Only	508 (17.92)	444 (15.66)	508 (17.92)
Clearance (limits)	Top land	.622-.851 (.0245-.0335)	
	Skirt	Top	.017-.107 (.0007-.0042)
		Bottom	
Ring groove diameter	No. 1 ring	84.33-84.71 (3.320-3.335)	
	No. 2 ring	84.33-84.71 (3.320-3.335)	
	No. 3 ring	83.82-84.20 (3.300-3.315)	

*Dressed engine mass (weight) includes the following:

* Rear of engine - drive takeoff.
 View from drive takeoff end to determine left & right side of engine.

MVMA Specifications Form
Passenger Car
METRIC (U.S. Customary)

Car Line MONTE CARLO
 Model Year 1980 Issued 10/79 Revised (*) _____

Engine Description / Carb.

3.8 Liter V-6/2-Bb1 (231 CID) RPO LD5	3.8 Liter V-6/4-Bb1 Turbocharged RPO LC8
--	---

Engine — General

*Total dressed engine mass (wt) dry		
Type (Inline, V and Angle, Flat) Location (Front, Mid, Rear)		90° 'V'
No. of cylinders		6
Bore		96.5 (3.80)
Stroke		86.4 (3.40)
Piston Displacement cm ³ (in ³)		3785 (231)
Bore Spacing (C/L to C/L)		107.7 (4.24)
Cyl. No. system (front to rear)**	L Bank	1-3-5
	R Bank	2-4-6
Firing Order		1-6-5-4-3-2
Cylinder Head Material		Cast Alloy Iron
Cylinder Block Material		Cast Alloy Iron
Cylinder block deck height		242.8 (9.56)
Number of mtg. points	Front	Two
	Rear	One
Engine installation position (transverse, Longitudinal)		Longitudinal
Recommended fuel Leaded, unleaded		Unleaded
Fuel antiknock index (R + M) 2		87
Cylinder Head Volume — cm ³		48.19
Head Gasket Thickness (Compressed)		.533
Head Gasket Volume — cm ³		3.93
Deck clearance (minimum) (above or below block)		1.91 below
Minimum Combustion Chamber Volume — cm ³		87.65

Engine — Pistons

Material		Cast Aluminum Alloy	
Description and finish		Full skirt with transverse slot, dished head	Closed skirt, dished head
Mass, g (weight, oz.) — Piston Only			
Clearance (Limits)	Top land		1.17-1.42 (.046 - .056)
	Skirt	Top	.020 - .050 (.0008 - .0020)
		Bottom	.030 - .090 (.0013 - .0035)
Ring groove diameter	No. 1 ring		85.98 - 86.36 (3.385 - 3.400)
	No. 2 ring		85.98 - 86.36 (3.385 - 3.400)
	No. 3 ring		85.93 - 86.26 (3.383 - 3.396)

* Dressed engine mass (weight) includes the following: Ready to run - front of engine to rear of engine block less radiator hoses, coolant, accelerator linkage and engine mountings.

** Rear of engine - drive takeoff.
View from drive takeoff end to determine left & right side of engine

MVMA Specifications Form
Passenger Car
METRIC (U.S. Customary)

Car Line MONTE CARLO
 Model Year 1980 Issued 10/79 Revised (*) _____

Engine Description/Carb.

3.8 Liter V-6/2-Bb1 (229 CID) RPO LC3	4.4 Liter V-8/2-Bb1 (267 CID) RPO L39	5.0 Liter V-8/4-Bb1 (305 CID) RPO LG4
--	--	--

Engine — Piston Rings

Function (top to bottom)	No. 1, oil or comp.	Compression	
	No. 2, oil or comp.	Compression	
	No. 3, oil or comp.	Oil	
Compres- sion	Description — Upper	(a)	Cast alloy iron, radius face, .0004 chrome flash
	Material, coating, etc. Lower	(b)	Cast alloy iron, reverse twist, tapered face, lubricated
	Width	1.96-1.98 (.0770 - .0780)	
	Gap	Upper - 0.25- 0.51 (.010 - .020) (c)	
Oil	Description — material, coating, etc.	TRW 'T' flex design, .05 mm (.002" minimum chrome)	
	Width	4.52-4.62 (.178- .182)	
	Gap	0.25-0.89 (.010-.035)	
Expanders	In oil ring assembly		

Engine — Piston Pins

Material	SAE - 1018		
Length	75.95 - 76.45 (2.990 - 3.010)		
Diameter	23.546 -23.553 (.9270 - .9273)		
Type	Locked in rod, in piston, floating, etc.	Locked in rod	
	Bushing	In rod or piston	---
		Material	---
Clearance	In piston	(d)	(e) (f)
	In rod		
Direction & amount offset in piston	Major thrust side - 1.52 (.060)		

Engine — Connecting Rods

Material	1037 or 1038 steel	
Mass. g (weight. oz.)	388 (13.69)	
Length (center to center)	144.8 (5.70)	
Bearing	Material & Type	Premium aluminum
	Overall length	16.97 (.668) 20.24 (.797)
	Clearance (limits)	.025-.063 (.001-.0025) .033-.089 (.0013-.0035)
	End Play	.15-.38 (.006-.015) .15-.41 (.006-.016)

- (a) Molybdenum filled channel, barrel faced
 (b) Inside bevel, reverse tapered face, phosphate coated.
 (c) Lower - 229 & 267 CID - 0.25 - 0.64 (.010 - .025); 305 CID - 0.33 - 0.63
 (.013 - .025)
 (d) .0013 - .0075 (.00005 - .00030)
 (e) .0013 - .0075 (.00005 - .00030)
 (f) .0063 - .0089 (.00025 - .00035)

MVMA Specifications Form
Passenger Car
METRIC (U.S. Customary)

Car Line MONTE CARLO
 Model Year 1980 Issued 2/79 Revised (*) _____

Engine Description / Carb.

3.8 Liter V-6/2-Bb1 (231 CID) RPO LD5	3.8 Liter V-6/4-Bb1 Turbocharged RPO LC8
--	---

Engine — Piston Rings

Function (top to bottom)	No. 1. oil or comp.	Compression
	No. 2. oil or comp.	Compression
	No. 3. oil or comp.	Oil
Compression	Description — Material, coating, etc.	Upper: Molybdenum filled channel, barrel faced Lower: Inside bevel, reverse tapered face, phosphate coated*
	Width	4.27-4.52 (.168 - .178)
	Gap	0.33 - 0.58 (.013 - .023)
	Oil	Stainless steel - 50
Oil	Description — material, coating, etc.	Stainless steel - 50
	Width	3.43 - 3.51 (.135 - .142)
	Gap	0.38 - 0.89 (.015 - .035)
Expanders		Abutment type

Engine — Piston Pins

Material	SAE - 1018		
Length	73.66 (2.90)		
Diameter	23.853 - 23.860 (.9391 - .9394)		
Type	Locked in rod, in piston, floating, etc.	Pressed in rod	
	Bushing	In rod or piston	---
		Material	---
Clearance	In piston	.010 - .018 (.0004 - .0007)	
	In rod	.019 - .032 (.00075 - .00125)	
Direction & amount offset in piston	Major thrust side - .102 (.040)		

Engine — Connecting Rods

Material	Cast Arma Steel	
Mass, g (weight, oz.)		
Length (center to center)	151.4 (5.96)	
Bushing	Material & Type	Premium Aluminum
	Overall length	16.61 (.654)
	Clearance (limits)	.013 - .066 (.0005 - .0026)
	End Play	.15 - .58 (.006 - .023)

* - Lubricated for LC8

MVMA Specifications Form
Passenger Car
METRIC (U.S. Customary)

Car Line MONTE CARLO
 Model Year 1980 Issued 10/79 Revised (*) _____

Engine Description / Carb.	3.8 Liter V-6/2-Bb1 (229 CID) RPO LC3	4.4 Liter V-8/2-Bb1 (267 CID) RPO L39	5.0 Liter V-8/4-Bb1 (305 CID) RPO LG4
----------------------------	--	--	--

Engine — Crankshaft

Material	Nodular cast iron		
Vibration damper type	Rubber mounted inertia		
End thrust taken by bearing (No.)	4	5	
Crankshaft end play	.051-.152 (.002-.006)	.051-.178 (.002-.007)	
Main bearing	Material & type	#1-G66 Conecc; #2,3,4 - M400	
	Clearance	Front-.020-.051 (.0008-.0020); Inter.-.028-.058 (.0011-.0023) (a)	
	Journal dia. and bearing overall length	No. 1	62.202 x 20.37 (2.4489 x .802)
		No. 2	62.194 x 20.37 (2.4486 x .802)
		No. 3	62.194 x 20.37 (2.4486 x .802)
		No. 4	62.189 x 38.94
		No. 5	62.194 x 20.37 (2.4486 x .802)
		No. 6	62.189 x 38.94 (2.4484 x 1.533)
No. 7		---	
Dir. & amt. cyl. offset	---		
No. bolts/main brg. cap	Two		
Crankpin journal diameter	53.284-53.335 (2.0978-2.0998)	53.31-53.34 (2.099-2.100)	

Engine — Camshaft

Location	In block above crankshaft		
Material	Cast alloy iron		
Bearings	Material	Steel backed babbitt	
	Number	4	
Type of Drive	Gear, chain or belt	Chain	
	Crankshaft gear or sprocket material	Steel	
	Camshaft gear or sprocket material	Sintered iron	
	Timing chain	Cast iron	Aluminum - nylon
		No. of links	46
		Chain or Belt	
Chain or Belt	Width	15.87 (.625)	
	Pitch	12.7 (.500)	

(a) Rear - .043 - .081 (.0017 - .0032)

MVMA Specifications Form
Passenger Car
METRIC (U.S. Customary)

Car Line MONTE CARLO
 Model Year 1980 Issued 10/79 Revised (*) 2/80

Engine Description / Carb.

3.8 Liter V-6/2-Bb1 (231 CID) RPO LD5	3.8 Liter V-6/4-Bb1 Turbocharged RPO LC8
--	---

Engine — Crankshaft

Material		Nodular cast iron		
Vibration damper type		Rubber mounted inertia		
End thrust taken by bearing (No.)		Two		
Crankshaft end play		.08 - .23 (.003 - .009)		
Main bearing	Material & type	#1 upper - M400 Conecc; #1 lower - M100 Conecc; #2&3-M400 #4 - M100		
	Clearance	.010 - .040 (.0004 - .0017)		
	Journal dia. and bearing overall length	No. 1	63.487 x 21.95 (2.4995 x .864)	
		No. 2	63.487 x 26.85 (2.4995 x 1.057)	
		No. 3	63.487 x 21.95 (2.4995 x .864)	
		No. 4	63.487 x 21.95 (2.4995 x .864)	
		No. 5	---	
		No. 6	---	
		No. 7	---	
Dir. & amt. cyl. offset	---			
No. bolts/main brg. cap	Two			
Crankpin journal diameter		57.12 - 57.14 (2.2487 - 2.2495)		

Engine — Camshaft

Location		In block above crankshaft		
Material		Cast alloy iron		
Bearings	Material	Steel backed babbitt		
	Number	4		
Type of Drive	Gear, chain or belt		Chain	
	Crankshaft gear or sprocket material		Sintered iron	
	Camshaft gear or sprocket material		Aluminum - nylon	
	Timing chain	No. of links	54	
	Chain or Belt	Width	22.23 (.875)	
Pitch		9.53 (.375)		

MVMA Specifications Form
Passenger Car
METRIC (U.S. Customary)

Car Line MONTE CARLO
 Model Year 1980 Issued 10/79 Revised (*) _____

Engine Description/Carb.

3.8 Liter V-6/2-Bb1 (229 CID) RPO LC3	4.4 Liter V-8/2-Bb1 (267 CID) RPO L39	5.0 Liter V-8/4-Bb1 (305 CID) RPO LG4
--	--	--

Engine — Valve System

Hydraulic lifters (Std., opt., NA)		Standard			
Valve rotator, type (intake, exhaust)		Exhaust			
Push rods (dia., length, material)		7.9 x 196.2 (.3125 x 7.724) welded steel tubing			
Rocker ratio		1.50:1			
Operating tappet clearance (indicate hot or cold)	Intake	Zero			
	Exhaust	Zero			
Timing (based on top of ramp points)	Intake	Opens (*BTC)	42	28	
		Closes (*ABC)	78	64	
		Duration (deg.)	300	272	
	Exhaust	Opens (*BBC)	78	78	
		Closes (*ATC)	52	30	
		Duration (deg.)	310	288	
Valve open overlap (deg.)		94	58		
Intake Valve	Material		SAE 1541 or 1547 (a)	SAE 1541-H steel (a) 21-2N (b)	
	Overall length		124.52 - 125.03 (4.9024 - 4.9224)		
	Actual overall head dia.		46.61-46.86 (1.835-1.845)	43.7 (1.72) 46.7 (1.84)	
	Angle of seat & face (deg.)		46,45		
	Seat insert material		None		
	Stem diameter		8.661-8.679 (.3410 - .3417)		
	Stem to guide clearance		.025 - .069 (.0010 - .0027)		
	Lift (at zero lash)		9.47 (.373)	9.07 (.357)	
	Outer Spring press. & length	Valve closed — N at mm (lb. at in.)		338.1 - 373.6 @ 43.2 (76-84 @ 1.70)	
		Valve open — N at mm (lb. at in.)		778 @ 31.7 (175 @ 1.25)	
	Inner spring press. & length	Valve closed — N at mm (lb. at in.)		Spring damper	
		Valve open — N at mm (lb. at in.)		Spring damper	
	Exhaust Valve	Material		21-2N steel, chrome flash stem	
		Overall length		124.71-125.02 (4.910-4.930)	124.79-125.3 (4.913-4.933)
Actual overall head dia.		38.1 (1.50)	35.1 (1.38) 38.1 (1.50)		
Angle of seat & face (deg.)		46,45			
Seat insert material		None			
Stem diameter		8.661-8.679 (.3410 - .3417)			
Stem to guide clearance		.025 - .069 (.0010 - .0027)			
Lift (at zero lash)		10.4 (.410)	9.91 (.390)		
Outer spring press. & length		Valve closed — N at mm (lb. at in.)		338.1-373.6 @ 43.2 (76-84 @ 1.70)	
		Valve open — N at mm (lb. at in.)		845 @ 31.7 (190 @ 1.25) 818 @ 31.7 (184 @ 1.25)	
Inner spring press. & length	Valve closed — N at mm (lb. at in.)		Spring damper		
	Valve open — N at mm (lb. at in.)		Spring damper		

(a) Chrome flash stem.

MVMA-C-80

(b) Full chrome.

MVMA Specifications Form
Passenger Car
METRIC (U.S. Customary)

Car Line MONTE CARLO
 Model Year 1980 Issued 10/79 Revised (*) _____

Engine Description / Carb.

3.8 Liter V-6/2-Bb1 (231 CID) RPO LD5	3.8 Liter V-6/4-Bb1 Turbocharged RPO LC8
--	---

Engine — Valve System

Hydraulic lifters (Std., opt., NA)		Standard		
Valve rotator, type (intake, exhaust)		None		
Push rods (dia., length, material)		7.94 x 220.9 (.3125 x 8.697) .060" wall steel tubing		
Rocker ratio		1.55:1		
Operating tappet clearance (indicate hot or cold)	Intake	Zero		
	Exhaust	Zero		
Timing (based on top of ramp points)	Intake	Opens (*BTC)	16	
		Closes (*ABC)	63 53	
		Duration (deg.)	259 249	
	Exhaust	Opens (*BBC)	68	
		Closes (*ATC)	29	
		Duration (deg.)	277	
Valve open overlap (deg.)		45		
Intake Valve	Material		1541 Steel, chrome flash stem	
	Overall length		119.33 - 120.09 (4.698 - 4.728)	
	Actual overall head dia.		43.43 (1.710)	
	Angle of seat & face (deg.)		45	
	Seat insert material		None	
	Stem diameter		8.64 - 8.66 (.3402 - .3412)	
	Stem to guide clearance		.038 - .089 (.0015 - .0035)	
	Lift (at zero lash)		9.07 (.357) 8.66 (.341)	
	Outer Spring press. & length	Valve closed — N at mm (lb. at in.)	262.4 - 306.9 @ 43.86 (59 - 69 @ 1.727)	
		Valve open — N at mm (lb. at in.)	774 - 845.2 @ 34.04 (174 - 190 @ 1.34)	
	Inner spring press. & length	Valve closed — N at mm (lb. at in.)	Spring damper	
		Valve open — N at mm (lb. at in.)	Spring damper	
	Exhaust Valve	Material		21-2N steel, chrome flash stem
		Overall length		119.46 - 120.22 (4.703 - 4.733)
Actual overall head dia.		38.1 (1.50)		
Angle of seat & face (deg.)		45		
Seat insert material		None		
Stem diameter		8.649 - 8.666 (.3405 - .3412)		
Stem to guide clearance		.038 - .081 (.0015 - .0032)		
Lift (at zero lash)		9.30 (.366) 9.30 (.366)		
Outer Spring press. & length		Valve closed — N at mm (lb. at in.)	262.4 - 306.9 @ 43.86 (59 - 69 @ 1.727)	
		Valve open — N at mm (lb. at in.)	773.9 - 845.1 @ 34.04 (174 - 190 @ 1.34)	
Inner spring press. & length	Valve closed — N at mm (lb. at in.)	Spring damper		
	Valve open — N at mm (lb. at in.)	Spring damper		

MVMA Specifications Form
Passenger Car
METRIC (U.S. Customary)

Car Line **MONTE CARLO**
 Model Year **1980** Issued **10/79** Revised (*)

Engine Description/Carb.	3.8 Liter V-6/2-Bb1 (229 CID) RPO LC3	4.4 Liter V-8/2-Bb1 (267 CID) RPO L39	5.0 Liter V-8/4-Bb1 (305 CID) RPO LG4
--------------------------	--	--	--

Engine — Lubrication System

Type of lubrication (splash, pressure, nozzle)	Main bearings	Pressure	
	Connecting rods	Pressure	
	Piston pins	Splash	
	Camshaft bearings	Pressure	
	Tappets	Pressure	
	Timing gear or chain	Splash and nozzle	
	Cylinder walls	Splash	Pressure, jet cross sprayed
Oil pump type		Gear	
Normal oil pressure-kPa (Psi) at engine rpm		310.3 (45)	
Type oil intake (floating, stationary)		Stationary	
Oil filter system (full flow, part, other)		Full flow	
Capacity of c/case, less filter-refill-L (qt.)		3.8 (4.0)	
Oil grade recommended (SAE viscosity and temperature range)	Minus 6.6°C (20°F) & above - 20W-20, 10W-30, 10W-40, 20W-40, 20W-50 Minus 17.7°C to +15.5°C (0 to 60°F) - 10W, 5W-30, 10W-40, 10W-30 Minus 6.6°C (20°F) & below - 5W-20, 10W-30		
Engine service reqmt. (SD, SE, etc.)	SE		

Engine — Exhaust System

Type (single, single with cross-over, dual, other)	Single W/Crossover		
Muffler No. & Type (reverse flow, straight thru, separate resonator)	One, Reverse Flow		
Resonator No. & type	None		
Exhaust Pipe	Branch O.D., wall thickness	50.8 (2.0)	50.8 (2.0)
	Main O.D., wall thickness	57.15 (2.25)	63.5 (2.5)
	Material	Laminated stainless steel tubing	
Inter-mediate Pipe	O.D. & wall thickness	50.8 (2.0)	50.8 (2.0) 57.15 (2.25)
	Material	Alum.coated tubing	Laminated steel tubing
Tail Pipe	O.D. & wall thickness	50.8 (2.0)	50.8 (2.0) 57.15 (2.25)
	Material	Aluminum coated tubing	

MVMA Specifications Form
Passenger Car
METRIC (U.S. Customary)

Car Line MONTE CARLO
 Model Year 1980 Issued 10/79 Revised (*)

Engine Description/Carb.

3.8 Liter V-6/2-Bb1 (231 CID) RPO LD5	3.8 Liter V-6/4-Bb1 Turbocharged RPO LC8
--	---

Engine — Lubrication System

Type of lubrication (splash, pressure, nozzle)	Main bearings	Pressure	
	Connecting rods	Pressure	
	Piston pins	Splash	
	Camshaft bearings	Pressure	
	Tappets	Pressure	
	Timing gear or chain	Splash & Nozzle	
	Cylinder walls	Splash	
Oil pump type		Gear	
Normal oil pressure-kPa(Psi) at engine rpm	310.3 (45)		255 (37)
Type oil intake (floating, stationary)		Stationary	
Oil filter system (full flow, part, other)		Full flow	
Capacity of c/case, less filter-refill-L(qt.)		3.8 (4.0)	
Oil grade recommended (SAE viscosity and temperature range)	Minus 6.6°C (20°F) & above - 20W-20, 10W-30, 10W-40, 20W-40, 20W-50 Minus 17.7°C to +15.5°C (0 to 60°F) - 10W, 5W-30, 10W-40, 10W-30 Minus 6.6°C (20°F) & below - 5W-20, 10W-30		
Engine service reqmt. (SD, SE, etc.)		SE	

Engine — Exhaust System

Type (single, single with cross-over, dual, other)	Single W/Crossover		
Muffler No. & Type (reverse flow, straight thru, separate resonator)	One, Reverse Flow		
Resonator No. & type	None		
Exhaust Pipe	Branch O.D., wall thickness	50.8 (2.0)	
	Main O.D., wall thickness	57.15 (2.25)	63.5 (2.50)
	Material	Laminated stainless steel tubing	
Intermediate Pipe	O.D. & wall thickness	50.8 (2.0)	57.15(2.25)
	Material	Aluminum coated tubing	Laminated Steel Tubing
Tail Pipe	O.D. & wall thickness	50.8 (2.0)	57.2 (2.25)
	Material	Aluminum Coated Tubing	

MVMA Specifications Form
Passenger Car
METRIC (U.S. Customary)

Car Line **MONTE CARLO**
 Model Year **1980** Issued **10/10** Revised (*) **2/80**

Engine Description/Carb.	3.8L/2-Bb1 (229 CID) V6 RPO LC3	3.8 Liter V6 (231 CID) 2-Bb1 RPO LD5	4-Bb1 Turbocharge RPO LC8	4.4L/2-Bb1 (267 CID) V8 RPO L39	5.0L/4-Bb1 (305 CID) V8 RPO LG4
--------------------------	---------------------------------------	--	---------------------------------	---------------------------------------	---------------------------------------

Engine — Fuel System (See supplemental page for Details of Fuel Injection, Supercharger, Turbocharger, etc. if used)

Inductions type: Carburetor, fuel injections, etc.		Carburetor				
Fuel Tank	Refill capacity — L (U.S. gals.)	68.5 (18.1) Approximately				
	Filler location	Rear center behind hinged license plate				
Fuel Pump	Type (elec. or mech.)	Mechanical				
	Locations one engine	Lower RF	Lower LF	Lower R.F.		
	Pressure range — kPa (psi)	31-41(4.5-6.0)	29-40(4.25-5.75)	52-62(7.5-9.0)		
Fuel Filter	Type	Fine mesh plastic strainer in gasoline tank and				
	Locations	paper filter element in carburetor inlet				
Carburetor	Choke type	Electric		Electric		
	Intake manifold heat control (exhaust or water)	Exhaust				
	Air cleaner type	Standard	Replaceable paper element, single snorkel			
		Optional				
	Idle spd. rpm (spec. neutral or drive)	Manual				
Propane (Neu.)						
Automatic		600/D	550/D	650/D	500/D (550)	550/D
	Propane (Neu.)					
Idle A/F mix.						

Carburetor Supplementary Information

Model Usage	Engine Displ. — L (in. ³)	Transmission	Carburetors		No. Used and Type	Barrel Size
			Make	Model		
All	3.8 (229)	Automatic	Rochester	17080146	One, 2-bb1	Pri & Sec. 35.1 (1.38)
	3.8 (231)	Automatic	Rochester	(17080493)	One, 2-bb1	Pri & Sec. 36.5 (1.4375)
	3.8 (231)	Automatic	Rochester	17080243 (17080543)	One, 4-bb1	Pri-27.7(1.093) Sec-57.2(2.25)
	4.4 (267)	Automatic	Rochester	17080108	One, 2-bb1	Pri & Sec. 35.1 (1.38)
	5.0 (305)	Automatic	Rochester	17080202 (17080516)	One, 4-bb1	Pri-35.1 (1.38) Sec-57.2 (2.25)

Data in brackets () pertains to California.

MVMA Specifications Form
Passenger Car
METRIC (U.S. Customary)

Car Line **MONTE CARLO**
 Model Year **1980** Issued **10/79** Revised (*)

Engine Description/Carb.

3.8L/2-Bb1 (229 CID) V6 RPO LC3	3.8 Liter V6 (231 CID) 2-Bb1 RPO LD5	4-Bb1 Turbocharge RPO LC8	4.4L/2-Bb1 (267 CID) V8 RPO L39	5.0L/4-Bb1 (305 CID) V8 RPO LG4
---------------------------------------	--	---------------------------------	---------------------------------------	---------------------------------------

Engine — Cooling System

Coolant recovery system (std., opt., none)		Standard				
Radiator cap relief valve pressure — kPa (psi)		103.4 (15)				
Circulation thermostat	Type (choke, bypass)	Choke				
	Starts to open at °C (°F)	90.6 (195)				
Water pump	Type (centrifugal, other)	Centrifugal				
	GPM 1000 pump rpm					
	Number of pumps	One				
	Drive (V-belt, other)	'V' belt				
	Bearing Type	Permanently lubricated double row ball				
By-pass recirculation type (inter., ext.)		Internal	External	Internal		
Radiator core type (cross-flow, vertical, cellular, tube and fin, other)		Cross flow, tube and center				
Cooling System Capacity	With heater — L (qt.)	18.67	15.42	21.87	19.57	
	Without heater — L (qt.)	Base Equipment				
	Opt. equipment specify — L (qt.)	18.38	15.15	21.59	20.02	
Water jackets full length of cyl. (yes, no)		Yes				
Water all around cylinder (yes, no)		Yes				
Radiator hose	Lower	Number and type (molded, straight)	One, molded			
		Inside diameter	38.1 (1.50)			
	Upper	Number and type (molded, straight)	One, molded			
		Inside diameter	38.1 (1.50)			
	By-pass	Number and type (molded, straight)	None	One, molded	None	
		Inside diameter	15.9 (.625)			
Radiator (Core)	Standard	Width	528 (20.8)	668 (26.3)		
		Height	431 (16.97)			
		Thickness	31.5 (1.24)	25 (0.98)	31.5 (1.24)	
	A/C	Width	528 (20.8)	668 (26.3)		
		Height	431 (16.97)	431 (16.97)	429 (16.89)	
		Thickness	31.5 (1.24)	31.5 (1.24)	25 (0.98)	
	Heavy duty	Width	528 (20.8)	668 (26.3)		
		Height	431 (16.97)			
		Thickness				
	Fan (Standard)	Number of blades & spacing		4, staggered		
Diameter		483 (19.0)				
Ratio — fan to crankshaft rev.		.95:1				
Fan cutout type		None				
Drive Type Number of Fans		'V' belt - one				
Fan (optional)	No. of blades and spacing		5, staggered			
	Diameter		50.8 (20.0)			
	Ratio — fan to crankshaft rev.		.95:1			
	Fan cut-out type		Clutch			
	Drive Type Number of Fans		'V' belt - one			

MVMA Specifications Form
Passenger Car
METRIC (U.S. Customary)

Car Line **MONTE CARLO**
 Model Year **1980** Issued **10/79** Revised (*) _____

Engine Description / Carb.	3.8 Liter V6/2-B. (229 CID) RPO LC3 All States Exc. Calif.	3.8 Liter V-6 (231 CID) 2-bbl RPO LD5 Calif. Only	4-5b1 Turbocharge RPO LC8 Federal	Calif.
----------------------------	---	---	---	--------

Vehicle Emission Control

Type (Air injection, engine modifications, other)	Air Injection		Air Injection		Air Injection		Air Injection	
	Type		W/C-4 System				W/C-4 System	
Air Injection Pump	Displacement — cm ³ (in ³)		(Computer				(Computer	
	Drive ratio		Controlled				Controlled	
	Drive type		Catalytic				Catalytic	
	Relief valve (type)		Converter)				Converter)	
	Filter (describe)							
	Air distribution (head, manifold, etc.)							
Air Injection System	Point of entry							
	Injection tube i.d.							
	Check valve type							
	Backfire protection (type)							
Exhaust Gas Recirculation System	Type (controlled flow, open orifice, other)		Controlled flow					
	Valve type		Vacuum modulated shut-off & metering valve					
	Valve location		Inlet manifold					
	Control energy source		Carburetor vacuum					
	Exhaust source		Manifold exhaust crossover					
	Exhaust cooler type		None					
	Orifice no. and size		One; 0.76 (0.030)					
	Point of exhaust injection (spacer, carburetor, manifold, other)		Inlet manifold					
Catalytic Converter System	Catalyst	Type	Platinum-Palladium					
		Volume — L (in ³)	2.6 (160)	4.26 (260)			(*)	
	Substrate type		Bead				Monolith	
	Container location		Beneath right front underbody					
Other	Carburetor Hot Air		Thermostatically controlled air cleaner regulates and mixes heated air with incoming cold air to reduce hydro-carbon emission.					

* - 260 Federal
 170 California

MVMA Specifications Form
Passenger Car
METRIC (U.S. Customary)

Car Line MONTE CARLO
 Model Year 1980 Issued 10/79 Revised (•) _____

Engine Description / Carb.

4.4L/2-Bbl V6 (267 CID) RPO L39 All States Exc. Calif.	5.0 Liter V8/2-Bbl (305 CID) RPO LG4 All States Exc. Calif.	Calif. Only
---	--	-------------

Vehicle Emission Control

Air Injection Pump	Type (Air injection, engine modifications, other)	Air Injection	Air Injection
	Type		W/C-4 System
Air Injection System	Displacement — cm ³ (in ³)		(Computer
	Drive ratio		Controlled
	Drive type		Catalytic
	Relief valve (type)		Converter)
	Filter (describe)		
	Air distribution (head, manifold, etc.)		
Exhaust Gas Recirculation System	Point of entry		
	Injection tube i.d.		
	Check valve type		
	Backfire protection (type)		
	Type (controlled flow, open orifice, other)	CONTROLLED FLOW	
	Valve type	Vacuum modulated shut-off & metering valve	
	Valve location	Inlet manifold	
	Control energy source	Carburetor vacuum	
Catalytic Converter System	Exhaust source	Manifold exhaust crossover	
	Exhaust cooler type	None	
	Orifice no. and size	One; 0.76 (0.030)	
	Point of exhaust injection (spacer, carburetor, manifold, other)	Inlet manifold	
Catalytic Converter System	Catalyst Type	Platinum - Palladium	
	Volume — L (in ³)	4.26 (260)	
	Substrate type	Bead	
Other	Container location	Beneath right front underbody	
	Carburetor Hot Air	Thermostatically controlled air cleaner regulates and mixes heated air with incoming cold air to reduce hydrocarbon emission.	

MVMA Specifications Form
Passenger Car
METRIC (U.S. Customary)

Car Line **MONTE CARLO**
 Model Year **1980** Issued **10/79** Revised (*) _____

Engine Description/Carb.

3.8L V6/2-Bb1 (229 CID) RPO LC3	3.8L V6 (231 CID) 4-bb1 Turbocharge RPO LC8
---------------------------------------	---

Vehicle Emission Control (Continued)

Crankcase Emission Control	Type (ventilates to atmos., induction system, other)	Standard	Induction system		
		Optional	---		
	Control Unit	Make and model	A.C.		
		Location	Intake Manifold	Valve Rocker Cover	
		Energy source (manifold vacuum, carburetor, other)	Manifold Vacuum		
		Control method (variable orifice, fixed orifice, other)	Variable Orifice		
	Complete System	Discharges (to intake manifold, other)	Intake Manifold		
		Air inlet (breather cap, other)	Carburetor Air Cleaner		
		Flame arrestor (screen, other)	Screen		
	Evaporative Emission Control	Fuel Tank	Thermal expansion volume — dm ³ (ft ³)	Approximately 10% of refill capacity	
Relief Pressure kPa (psi) and location					
Vacuum relief kPa (psi) and location					
Vapor-liquid separator type			Integral with fuel tank		
Vapor vented to (crankcase, canister, other)			Canister		
Carburetor		Vapor vented to (crankcase, canister, other)	Canister		
Vapor Storage	Storage provision (crankcase, canister, other)	Canister			
		Volume — dm ³ (ft ³) or capacity (grams)	Approx. 50 grams storage capacity		
	Control valve type	Controlled by orifice and carburetor throttle body and throttle blade position.			

MVMA Specifications Form
Passenger Car
METRIC (U.S. Customary)

Car Line MONTE CARLO
 Model Year 1980 Issued 10/79 Revised (*) _____

Engine Description/Carb.

4.4 Liter V-8/2-Bb1 (267 CID) RPO L39	5.0 Liter V-8/4-Bb1 (305 CID) RPO LG4
--	--

Vehicle Emission Control (Continued)

Crankcase Emission Control	Type (ventilates to atmos., induction system, other)		Standard	Induction system
			Optional	---
	Control Unit	Make and model		A.C.
		Location		Valve Rocker Cover
		Energy source (manifold vacuum, carburetor, other)		Manifold Vacuum
		Control method (variable orifice, fixed orifice, other)		Variable orifice
	Complete System	Discharges (to intake manifold, other)		Intake manifold
		Air inlet (breather cap, other)		Carburetor air cleaner
		Flame arrestor (screen, other)		Screen
	Evaporative Emission Control	Fuel Tank	Thermal expansion volume — dm ³ (ft ³)	
Relief Pressure kPa (psi) and location				
Vacuum relief kPa (psi) and location				
Vapor-liquid separator type			Integral with fuel tank	
Vapor vented to (crankcase, canister, other)			Canister	
Carbu- etor		Vapor vented to (crankcase, canister, other)		Canister
Vapor Storage		Storage provision (crankcase, canister, other)		Canister
		Volume — dm ³ (ft ³) or capacity (grams)		Approx. 50 grams storage capacity
		Control valve type		Controlled by orifice and carburetor throttle body and throttle blade position.

MVMA Specifications Form
Passenger Car
METRIC (U.S. Customary)

Car Line MONTE CARLO
 Model Year 1980 Issued 10/79 Revised (*) 2/80

Engine Description/Carb.	3.8L V6/2-B (229 CID) RPO LC3	3.8 Liter V6 (231 CID) 2-Bb1 RPO LD5	4-B T/Charge RPO LC8	4.4L V8/2-B (267 CID) RPO L39	5.0L V8/4-B (305 CID) RPO LG4
--------------------------	-------------------------------------	--	-------------------------	-------------------------------------	-------------------------------------

Electrical — Supply System

Battery	Make and Model	Delco 'Freedom'			
	Voltage Rtg. — V — & Total Plates	12-3200W	12V - 2500 Watt	12V-3200 Watts	
	SAE Designation No. and/or capacity	80 min. Res.Cap.	60 minute reserve capacity	80 Minute reserve capacity	
	Location	Engine compartment, right front			
Generator or Alternator	Make	Delco Remy			
	Model	1103161	1103043	1103100	
	Type and rating	37	42	55	
	Output at engine idle (neutral) A	37			
Regulator	Ratio — Gen. to Cr/s rev.	2.73:1	2.36:1	2.73:1	
	Make	Delco Remy			
	Model	---			
	Type	Micro circuit unit; integral with alternator			
	Regulated	Voltage	13.8-14.8		
		Current A	---		
	Voltage test conditions	Temperature — °C (°F)	Operating		
Load A		3 - 8			
Other		---			

Electrical — Starting System

Starting Motor	Make	Delco Remy			
	Model	1109524	1109061	1109524	
Motor Drive	Engagement Type	Positive shift solenoid			
	Pinion engages from (front, rear)	Rear	Front	Rear	
	Number of teeth	Pinion	9		
		Flywheel	Manual	Auto	---
		153	160	168	

MVMA Specifications Form
Passenger Car
METRIC (U.S. Customary)

Car Line MONTE CARLO
 Model Year 1980 Issued 10/79 Revised (*) _____

Engine Description / Carb.	3.8L V6/2-B (229 CID) RPO LC3	3.8 Liter V6 (231 CID) 2-Bb1 RPO LD5	4-B/T-Charge RPO LC8	4.4L V8/2-B (267 CID) RPO L39	5.0L V8/4-B (305 CID) RPO LG4
----------------------------	-------------------------------------	--	-------------------------	-------------------------------------	-------------------------------------

Electrical — Ignition System — Distributor

Distributor	Manual	---	---	---	---
	Automatic	1110752	(1110784)	1110550 (1110784)	1103382 1103384 (1103386)
Timing	Manual	---	---	---	---
	Automatic	10° BTC			4° BTC 4° BTC

Distributor Model	CENTRIFUGAL ADVANCE Crankshaft Degrees at Engine RPM			VACUUM ADVANCE Crankshaft Deg. at kPa (in. of Hg.)	
	Start	Intermediate	Maximum	Start	Maximum
1103382	0 @ 1200	8.0 @ 1700	22 @ 4400	0 @ 13.5	14 @ 27.0
1103384	0 @ 800	16 @ 2000	20 @ 4000	0 @ 13.5	15 @ 40.5
1103386	0 @ 1000	10 @ 1700	20 @ 3800	0 @ 13.5	16 @ 25.3
1110752	0 @ 1200	7 @ 2400	14 @ 4100	0 @ 10.1	16 @ 21.9
1110550					
1110784					

MVMA Specifications Form
Passenger Car
METRIC (U.S. Customary)

Car Line MONTE CARLO
 Model Year 1980 Issued 10/79 Revised (*) 2/80

Engine Description/Carb.

3.8L V6/2-B (229 CID) RPO LC3	3.8L V6 (231 CID) 2-Bb1 RPO LD5	4-B/T-Charge RPO LC8	4.4L V8/2-B (267 CID) RPO L39	5.0L V8/4-B (305 CID) RPO LG4
-------------------------------------	---------------------------------------	-------------------------	-------------------------------------	-------------------------------------

Electrical — Ignition System

Type	Conventional — Std., Opt., N.A.		---	
	Transistorized — Std., Opt., N.A.		---	
	Other (specify)		High Energy Ignition (H.E.I.)	
Coil	Make		Delco Remy	
	Model		Integral with distributor cap	
	Current	Engine stopped — A	---	
		Engine idling → A	---	
Spark Plug	Make		AC Spark Plug	
	Model	R45TS	R45TSX	R45JS
	Thread (mm)	14		
	Tightening torque — N-m (lb. ft.)	9-20 (7-15)		
	Gap	1.14 (.045)	1.52 (.060)	1.14 (.045)

Electrical — Suppression

Locations & type	
------------------	--

Electrical — Instrument and Equipment

Speed-ometer	Type	Circular dial with pointer
	Trip odometer (std., opt., N.A.)	NA
EGR maintenance indicator		NA
Charge Indicator	Type	Tell-Tale
	Warning device	NA
Temperature Indicator	Type	Tell-Tale
	Warning device	NA
Oil pressure Indicator	Type	Tell-Tale
	Warning device	NA
Fuel Indicator	Type	Electric Gauge
	Warning device	NA
Wind-shield Wiper	Type — standard	Electric Two-Speed
	Type — optional	Intermittent windshield wiper system
	Blade length	457 (18 in) ₂
	Swept area — cm ² (in. ²)	6000 (930.3 in ²)
Wind-shield Washer	Type — standard	Push-Button
	Type — optional	NA
	Fluid level indicator	NA
Horn	Type	Vibrator
	Number used	Dual
	Current draw (A) per horn	4.5-6.5 @ 12.5 Volts
Other	Restraint system warning light and buzzer. Parking brake and brake failure warning light, tachometer, voltmeter, oil pressure and coolant temperature gages, in optional package.	

MVMA Specifications Form
Passenger Car
METRIC (U.S. Customary)

Car Line **MONTE CARLO**
 Model Year **1980** Issued **10/79** Revised (*)

Engine Description/Carb.	3.8L V6/2-B (229 CID) RPO LC3	3.8L V6 (231 CID) 2-Bb1 RPO LD5	4-B/T-Charge RPO LC8	4.4L V8/2-B (267 CID) RPO L39	5.0L V8/4-B (305 CID) RPO LG4
--------------------------	-------------------------------------	---------------------------------------	-------------------------	-------------------------------------	-------------------------------------

Drive Units — Clutch (Manual Transmission)

Make & type	
Type pressure plate springs	
Total spring load — N (lb.)	
No. of clutch driven discs	NOT AVAILABLE
Clutch facing	Material
	Manufacturer
	Part Number
	Rivets/Plate
	Rivet size
	Outside & inside dia.
	Total eff. area - cm ² (in. ²)
	Thickness
Engagement cushion-method	
Release bearing	Type & method of lubrication
Torsional damping	Methods: springs, friction material

Drive Units — Transmissions

Manual 3-speed (std., opt., N.A.)	NA
Manual 4-speed (std., opt., N.A.)	NA
Manual 5-speed (std., opt., N.A.)	NA
Manual overdrive (std., opt., N.A.)	NA
Automatic (std., opt., N.A.)	Available

Drive Units — Manual Transmission

Number of forward speeds		
Transmission ratios	In first	
	In second	
	In third	NOT AVAILABLE
	In fourth	
	In fifth	
	In reverse	
Synchronous meshing, specify gears		
Shift lever location		
Lubricant	Capacity — L (pt.)	
	Type recommended	
	SAE viscosity number	Summer
		Winter
Extreme cold		

MVMA Specifications Form
Passenger Car
METRIC (U.S. Customary)

Car Line MONTE CARLO
 Model Year 1980 Issued 10/79 Revised (*) 2/80

Engine Description/Carb.

3.8L V6/2-B (229 CID) RPO LC3	3.8L V6 (231 CID) 2-bb1 RPO LD5	4-B/T-Charge RPO LC8	4.4L V8/2-B (267 CID) RPO L39	5.0L V8/4-B (305 CID) RPO LG4
-------------------------------------	---------------------------------------	-------------------------	-------------------------------------	-------------------------------------

(See "Power Teams" for Transmission Usage)

Drive Units — Automatic Transmission

Trade name	3-Speed Automatic	
Type (describe)	Torque Converter clutch ('200c', '250c' & '350c') Torque converter with planetary gears	
Selector location	Column mounted; floor mounted w/optional console	
Gear Ratios	P	Park
	R	2.07
	N	Neutral
	D	2.74-1.57-1.0
	L2	2.74-1.57
	L1	2.74
Max. upshift speed — drive range — km/h (mph)		
Max. kickdown speed — drive range — km/h (mph)		
Torque Converter	Number of elements	3
	Max. ratio at stall	2.35
	Type of cooling (air, liquid)	Liquid
	Nominal diameter mm (in)	298(11.75)
Lubricant	Capacity — refill — L (pt.)	4.0 (7.5)
	Type recommended	Dexron II
Special transmission features	200c, 250c & 350c feature converter lock-up final drives	

Drive Units — Axle

Type (front, rear)	Rear		
Description	Semi-floating axle shafts, overhung drive pinion and ring gear		
Limited Slip differential, type	Disc clutch		
Drive Pinion Offset	38.1 (1.50)		
No. of differential pinions	Two		
Pinion adjustment (shim, other)	Shim		
Pinion bearing adj. (shim, other)	Collapsible sleeve		
Wheel bearing type	Single row, cylindrical roller		
Lubricant	Capacity — L (pt.)	1.5 (3.25)	
	Type recommended	GL-5 Gear Lubricant	
	SAE viscosity number	Summer	80W or 80W-90
		Winter	80W or 80W-90
		Extreme cold	80W or 80W-90

Axle Ratio Tooth Combinations (See "Power Teams" for axle ratio usage.)

Axle Ratio (:1)	2.29	2.41	2.73
No. of teeth	Pinion	17	15
	Ring gear	39	41
Ring Gear O. D.	191 (7.50)		
Transaxle	Transfer Gear Ratio		
	Final Drive Ratio		

MVMA Specifications Form
Passenger Car
METRIC (U.S. Customary)

Car Line MONTE CARLO
 Model Year 1980 Issued 10/79 Revised (*) _____

Engine Description / Carb.

3.8L V6/2-B (229 CID) RPO LC3	3.8 Liter V6 (231 CID) 2-Bbl RPO LD5	4-B/T-Charge RPO LC8	4.4L V8/2-B (267 CID) RPO L39	5.0L V8/4-B (305 CID) RPO LG4
-------------------------------------	--	-------------------------	-------------------------------------	-------------------------------------

Drive Units — Propeller Shaft

Number used		One	
Type (straight tube, tube-in-tube, internal-external damper, etc.)		RPO	Straight tube
		K9	
Outer diam. x length* x wall thickness	Manual 3-speed trans.	Not Available	
	Manual 4-speed trans.	Not Available	
	Manual 5-speed trans.	Not Available	
	Overdrive	Not Available	
	Automatic transmission	63.5 x 1331.5 x 1.65 (2.5 x 52.42 x .065)	
Inter-mediate bearing	Type (plain, anti-friction)	None	
	Lubrication (fitting prepack)	---	
Slip Yoke	Type	Yoke	
	Number of teeth	27	
	Spline O.D.		
Universal joints	Make and Mfg. No.	K9	Saginaw 44
		Q9	
	Number used	Two	
	Type (ball and trunnion, cross)	Single Cardan	
	Rear attach (u-bolt, clamp, etc.)	Strap and bolt	
Bearing	Type (plain, anti-friction)	Anti-friction	
	Lubric. (fitting, prepack)	Pre-pack	
Drive taken through (torque tube or arms, springs)		Control Arm	
Torque taken through (torque tube or arms, springs)		Control Arm	

* Center to center of universal joints, or to centerline of rear attachment.

MVMA Specifications Form
Passenger Car
METRIC (U.S. Customary)

Car Line **MONTE CARLO**
 Model Year **1980** Issued **10/79** Revised (*)

Engine Description / Carb.

2-Door Sport Coupe

Drive Units — Tires And Wheels (Standard)

TIRES	Size, load range, ply		P205/70R-14 (B/W-std; W/W-opt)
	Type (bias, radial, etc.)		Steel belted radial
	Inflation pressure (cold) for recommended max. vehicle load	Front-kPa (psi)	180 (26)
		Rear-kPa (psi)	200 (29)
	Rev./mile—at 70 km/h (45 mph)		508 (818)
WHEELS	Type & material		Short spoke disc, steel
	Rim (size & flange type)		14 x 6
	Wheel offset		'0'
	Attachment	Type (bolt or stud)	Stud
		Circle diameter	120.7 (4.75)
		Number & size	5 hex nuts - 7/16 - 20
Spare wheel (same or other)		15 x 4 (25mm - 1.0 offset)	

Drive Units — Tires And Wheels (Optional)

Size, load range, ply		
Type (bias, radial, etc.)		
Wheel type & material		Rally type (RPO ZJ7) (a)
Rim (size, flange type, and offset)		14 x 6, '0'
Size, load range, ply		
Type (bias, radial, etc.)		
Wheel type & material		
Rim (size, flange type, and offset)		
Spare Tire		
Base		Compact - T125/70D-14
Opt.		Stowaway - T195/75D-14 (b)
Rim (size, flange type, and offset)		
Size, load range, ply		
Type (bias, radial, etc.)		
Wheel type & material		
Rim (size, flange type, and offset)		
Size, load range, ply		
Type (bias, radial, etc.)		
Wheel type & material		
Rim (size, flange type, and offset)		

Brakes — Parking

Type of control		Foot pedal - application; 'T' handle release
Location of control		Under instrument panel, left of steering column
Operates on		Rear service brakes
If separate from service brakes	Type (internal or external)	---
	Drum diameter	---
	Lining size (length x width x thickness)	---

- (a) N.A. with Landau option
- (b) Used with limited slip differential.

MVMA Specifications Form
Passenger Car
METRIC (U.S. Customary)

Car Line MONTE CARLO
 Model Year 1980 Issued 10/79 Revised (*) _____

Body Type And/Or Engine Displacement

2-Door Sport Coupe

Brakes — Service

Brake Type (std., opt., N.A.)	Drum	Front	N.A.	
		Rear	Std.	
	Disc	Front	Std.	
		Rear	N.A.	
Self-adjusting (std., opt., N.A.)			Std.	
Special Valving	Type (proportion, delay, metering, other)		Metering/proportioning	
Power Brake (std., opt., N.A.)			Std.	
Booster Type (remofe, integral, vac., hyd., etc.)			Integral	
Anti-skid device type (std., opt., N.A.)			N.A.	
Effective area — cm ² (in. ²)*			615.5 (95.42)	
Gross lining area — cm ² (in. ²)**				
Swept area — cm ² (in. ²)***			1985.1 (307.77)	
Rotor	Outer working diameter	F	266.7 (10.5)	
		R	---	
	Thickness	F	26.2 (1.03)	
		R	---	
	Material & type (vented/solid)	F	Cast iron, vented	
		R	---	
Drum	Diameter (nominal)	R	241 (9.5)	
	Type and material		Finned, cast iron (a)	
Wheel cylinder bore	Front		63.5 (2.50)	
	Rear		19.1 (0.75)	
Master Cylinder	Bore		24.0 (0.94)	
	Stroke		33.33 (1.31)	
Pedal arc ratio			3.5:1	
Line pressure at 445 N (100 lb.) pedal load—MPa (psi)				
Lining Clearance Per Shoe	Front		Self adjusting	
	Rear		Self adjusting	
Brake lining	Front Wheel	Bonded or riveted, rivets/seg.		Riveted, 8
		Rivet size		5.33 x 7.92 (.210 x .312)
		Manufacturer		Delco Moraine
		Lining Code		Ma., Inboard-GM110FF, Outboard-GM116FE; Power-GM333EE
		Material		Molded Asbestos
		Size	Prim. or out-board	125 x 48.4 x 11.04 (4.92 x 1.91 x .435)
	Rear Wheel	Size	Second or in-board	125 x 48.4 x 11.04 (4.92 x 1.91 x .435)
		Shoe thickness (no lining)		Inboard - 15.84 (.620); Outboard - 13.97 (.550)
		Bonded or riveted, rivets/seg.		Riveted - 10 primary, 12 secondary
		Manufacturer		Delco Moraine
		Lining Code		Primary-GM224FF; Secondary-GM235FF
		Material		Molded Asbestos
Size	Prim. or out-board	192.5 x 51.0 x 4.98 (7.58 x 2.0 x .196)		
Size	Second or in-board	249.6 x 51.0 x 6.75 (9.83 x 2.0 x .266)		
Shoe thickness (no lining)		9.7 (3.8)		

*Excludes rivet holes, grooves, chamfers, etc.

**Includes rivet holes, grooves, chamfers, etc.

***Total swept area for four brakes. (Drum brake: Widest lining contact width for each brake x its contact circumference.) (Disc brake Square of Outer Working Dia. minus Square of Inner Working Dia. multiplied by z/2 for each brake.)

****Size for drum brakes includes length x width x thickness.

(a) Finned aluminum with turbocharged V-6 engine or 5.0 liter California version powertrain.

MVMA Specifications Form
Passenger Car
METRIC (U.S. Customary)

Car Line MONTE CARLO
 Model Year 1980 Issued 10/79 Revised (*) _____

2-Door Sport Coupe

Steering

Manual (std., opt., N.A.)		---		
Power (std., opt., N.A.)		Std.		
Adjustable steering wheel (tilt, swing, other)	Type and description	Tilt-'U' joint steering shaft at base of steering wheel - 6 position - 5" vertical travel range		
	(Std., opt., N.A.)	Optional		
Wheel diameter	Manual	387 (15.0)		
	Power	387 (15.0)		
Turning diameter m (feet)	Outside front	Wall to wall (l. & r.)	12.4 (40.54)	
		Curb to curb (l. to r.)	11.3 (37.19)	
	Inside rear	Wall to wall (l. to r.)		
		Curb to curb (l. to r.)		
Manual	Gear	Type		
		Make		
		Ratios	Gear Overall	
	No. wheel turns (stop to stop)			
Power	Type (coaxial, linkage, etc.)		Integral gear & power piston with vane type gear	
	Make		Saginaw Steering Gear	
	Gear	Type	Semi-reversible recirculating ball nut	
		Ratios	Gear	14.0:1
		Overall	15.3:1	
Pump driven by		Crankshaft pulley		
No. wheel turns (stop to stop)		3.3		
Linkage	Type		Parallelogram	
	Location (front or rear of wheels, other)		Front	
	Drag links (trans. or longit.)		None	
	Tie rods (one or two)		Two	
Steering Axis	Inclination at camber (deg.)		7.86	
	Bearings (type)	Upper	Ball stud with non-metallic surfaces	
		Lower	Ball stud with non-metallic surfaces	
		Thrust	---	
Steering spindle & joint type		Forging with pad for mounting brake cylinder spherical		
Wheel Spindle	Diameter	Inner bearing	31.7 (1.25)	
		Outer bearing	21.4071 - 21.4274 (.843 - .844)	
	Thread size		3/4-20 UNEF-3A (modified)	
	Bearing type		Tapered roller	
Wheel Align at curb mass (wt.)	Service checking	Caster (deg.)	+2 to +4	
		Camber (deg.)	-0.3 to +1.3	
		Toe-in [outside track-mm (in.)]	0.5 to 0.25	
	Service reset	Caster	+3 ± 0.5	
		Camber	+0.5 ± 0.5	
		Toe-in	+1.5 ± .05	
	Periodic M.V. Inspection	Caster	+1 to +5	
		Camber	-1.0 to +2.0	
Toe-in		-0.15 to +0.55		

MVMA Specifications Form
Passenger Car
METRIC (U.S. Customary)

Car Line MONTE CARLO
 Model Year 1980 Issued 10/79 Revised (*) _____

Body Type And/Or Engine Displacement

2-Door Sport Coupe

Suspension — General

(See Supplement page for details on Air Suspension)

Provision for car leveling	Front Stabilizer Bar	
Provision for brake dip control	Front Suspension Geometry	
Provision for acc. squat control	Rear Suspension Geometry	
Special provisions for car jacking	Position jack in bumper slot on lower face of front & rear bumpers	
Shock absorber front & rear	Type	Direct. double acting, hydraulic
	Make	Delco
	Piston dia.	25 (1.0)
Other special features		

Suspension — Front

Type and description	Independent SLA	
Travel	Full Jounce	90 (3.54)
	Full Rebound	92 (3.62)
Spring	Type (coil, leaf, other)	Coil
	Material	Steel Alloy
	Size (coil design height & I.D., bar length x dia.)	260 x 102.9 x 2953 x 15.6 (10.2 x 4.05 x 116.3 x .610)
	Spring rate — N/mm (lb./in.)	58 (400)
	Rate at wheel — N/mm (lb./in.)	17.12 (118)
Stabilizer	Type (link, linkless, frameless)	Link
	Material & bar diameter	Steel - V-6 - 27(1.06); V-8 - 29(1.14); RPO F41 Sport

Suspension — Rear

Suspension - 32 (1.26)

Type and description	Salisbury, 4-link type	
Drive and torque taken through	Control Arms	
Travel	Full Jounce	107 (4.21)
	Full Rebound	113 (4.45)
Spring	Type (coil, leaf, other)	Coil
	Material	Steel Alloy
	Size (length x width, coil design height & I.D., bar length & dia.)	254 x 139.7 x 2428 x 12.8 (10.0 x 5.5 x 95.6 x .504)
	Spring rate — N/mm (lb./in.)	20.1 (139)
	Rate at wheel — N/mm (lb./in.)	19.8 (137)
	Mounting insulation type	---
	leaf	No. of leaves
Stabilizer	Type (link, linkless, frameless)	Link
	Material & bar diameter	Steel - V-6 - 16(.63); V-8 - 19(.75)
Track bar type	---	

MVMA Specifications Form
Passenger Car
METRIC (U.S. Customary)

Car Make **MONTI CARLO**
 Model Year **1980** Issued **10/79** Revised (*)

Body Type

2-Door Sport Coupe

Body — Miscellaneous Information

Type of finish (lacquer, enamel, other)		Acrylic Lacquer
Hood Hinge Location		Rear
Hood counterbalance (type)		Conventional 4-Link type with spiral spring
Hood release control (internal, external)		Internal
Vehicle Ident. No. Location		Top left hand of instrument panel pad
Vent window control method (crank, friction pivot, power)	Front	None
	Rear	None
Seat cushion type	Front	Formed full foam pad
	Rear	Formed full foam pad
	3rd Seat	---
Seat back type	Front	Formed full foam pad
	Rear	Formed full foam pad
	3rd Seat	---
Method of holding luggage compartment lid open		Boxed hinges with torsion rod
Position of spare tire storage		Semi-vertical - right rear trunk area

Frame

Type and description (Separate frame, unitized frame, partially-unitized frame)	Full frame, perimeter type
---	----------------------------

MVMA Specifications Forms
Passenger Car
METRIC (U.S. Customary)

Car Line MONTE CARLO
 Model Year 1980 Issued 10/79 Revised (*) _____

Body Type

2-Door Sport Coupe

Convenience Equipment

Power windows	Side Windows	Optional
	Vent Windows	NA
	Backlight or tailgate	---
Power seats (specify type as well as availability)		Optional - 6-way 55/45 power bench seat, drivers only. - 6-way power bench seat.
Reclining front seat back (R-L or both)		NA
Radios (specify type as well as availability)		Optional - AM Push button, AM/FM Push Button, AM/FM Stereo, AM Radio with Stereo 8-track tape, AM/FM Stereo W/8-Track Tape (a) (b)
Rear seat speaker		Optional
Power antenna		Optional
Clock		Standard
Air Conditioner (specify type)		Optional - "Four Season" manual controls
Speed warning device		NA
Speed control device		Optional with automatic transmission
Ignition lock lamp		NA
Dome lamp		Standard
Glove compartment lamp		Standard
Luggage compartment lamp		Optional
Underhood lamp		Optional
Courtesy lamp		Standard
Map lamp		NA
Cornering lamp		NA
Rear window defroster electrically heated		Optional
Theft protection - type		Lock mounted on steering column; locks steering wheel, transmission, shift lever and ignition.
Ash tray lamp		Standard

- (a) Radio - AM/FM monaural with citizen's band transceiver, AM/FM Stereo with citizen's band transceiver, AM/FM stereo with cassette player.
- (b) Stereo equipment includes 2 front and 2 rear speakers.

MVMA Specifications Form

Passenger Car

METRIC (U.S. Customary)

Car Line MONTE CARLO

Model Year 1980

Issued 10/79

Revised (*)

Optional Equipment Mass (Weight)*

Equipment Differential Mass (Weights)	MASS, kg. (Weight, lb.)			Remarks
	Front	Rear	Total	
Air Conditioning	33.6	2.6	36.2	With V6 Engine
4-Season	(+74.1)	(+5.7)	(+79.8)	
	24.6	2.0	26.6	With V8 Engine
	(+54.2)	(+4.4)	(+58.6)	
Electric Door Locks	1.2	0.8	2.0	
	(+ 2.6)	(+1.8)	(+4.4)	
Power Windows	1.8	1.8	3.6	
	(+4)	(+4)	(+8)	
Power Seat 6-way Bench	4.2	3.8	8.0	
	(+9)	(+8.5)	(+17.5)	
Power Seat 6-way 55/45 Seat	4.4	3.8	8.2	
	(+9.7)	(+8.4)	(+18.1)	
Vinyl Roof Cover (Padded)	1.6	1.6	3.2	
	(+3.5)	(+3.5)	(+7)	
Floor Mats Front & Rear	2.0	1.2	3.2	
	(+4.5)	(+2.5)	(+7)	
Front Compartment Console	4.6	1.6	6.2	With Automatic Transmission
	(+10)	(+3.5)	(+13.5)	
Radio AM Pushbutton	2.0	0.2	2.2	
	(+4.5)	(+0.4)	(+4.9)	
Radio AM/FM Pushbutton	2.2	0.6	2.8	
	(+4.9)	(+1.3)	(+6.2)	
Radio AM/FM Stereo	4.8	1.0	5.8	
	(+10.6)	(+2.2)	(+12.8)	
Radio AM Pushbutton & Stereo Tape Player	5.2	1.0	6.2	
	(+11.5)	(+2.2)	(+13.7)	
Radio AM/FM Pushbutton & Stereo Tape Player	5.4	1.0	6.4	
	(+11.9)	(+2.2)	(+14.1)	
Radio AM/FM Stereo With Cassette Player	4.6	1.6	6.2	
	(+10.1)	(+3.6)	(+13.7)	
Radio AM/FM Monaural With Citizen's Band Transceiver	2.4	0.6	3.0	
	(+5.3)	(+1.3)	(+6.6)	

* Also see Engine -- General Section for dressed engine mass (weight).

MVMA Specifications Form
Passenger Car
METRIC (U.S. Customary)
Car and Body Dimensions See Key Sheets for definitions

Car Line MONTE CARLO
 Model Year 1980 Issued 10/79 Revised (*) _____

All dimensions to ground are for comparative purposes only. Dimensions are to be shown for all base body models of each car line.
 SAE Ref. No. refers to the definition published in SAE Recommended Practice.
 J1100a "Motor Vehicle Dimensions," unless otherwise specified.

Body Type

SAE Ref. No.	2-Door Sport Coupe
---------------------	---------------------------

Width

Tread — Front	W101	1486 (58.5)
Tread — Rear	W102	1467 (57.8)
Vehicle width	W103	1816 (71.5)
Body width at Sg RP — front	W117	1783 (70.2)
Vehicle width — front doors open	W120	3989 (57.0)
Vehicle width — rear doors open	W121	---

Length

Wheelbase	L 101	2745 (108.1)
Vehicle length	L 103	5090 (200.4)
Overhang — front	L 104	1077 (42.4)
Overhang — rear	L 105	1268 (49.9)
Upper structure length	L 123	2303 (90.7)
Rear wheel C/L "X" coordinate	L 127	2377 (93.6)
Cowl point "X" coordinate	L 125	158 (6.2)

Height *

Passenger Distribution (frt./rear)	PD1.2.3	2-3
Trunk/Cargo load		0
Vehicle height	H 101	1368 (53.9)
Cowl point to ground	H 114	974 (38.3)
Deck point to ground	H 138	
Rocker panel front to ground	H 112	215 (8.5)
Bottom of door closed - front to grd.	H 133	265 (10.4)
Rocker panel rear to ground	H 111	208 (8.2)
Bottom of door closed - rear to grd.	H 135	---

Ground Clearance *

Front bumper to ground	H102	332 (13.1)
Rear bumper to ground	H104	316 (12.5)
Bumper to ground — front at curb mass (wt.)	H103	354 (13.9)
Bumper to ground — rear at curb mass (wt.)	H105	360 (14.2)
Angle of approach	H106	19.20°
Angle of departure	H107	14.80°
Ramp breakover angle	H147	13.43°
Rear axle differential to ground	H153	149 (5.9)
Min. running ground clearance	H156	118 (4.6)
Location of min. run. grd. clear.		Rear shock absorber bracket

All linear dimensions are in millimeters (inches) and all mass (weight) specifications are in kilograms (pounds).

* All vehicle height and ground clearances are made at the Manufacturer's Design Load Weight, unless otherwise specified. Manufacturer's Design Load Weight is defined with indicated passenger distribution and trunk/cargo load.

MVMA Specifications Form

Passenger Car
METRIC (U.S. Customary)

Car and Body Dimensions See Key Sheets for definitions

Car Line MONTE CARLO
Model Year 1980 Issued 10/79 Revised (*) _____

Body Type

SAE Ref. No.	2-Door Sport Coupe
--------------------	--------------------

Front Compartment

Sg RP front, "X" coordinate	L31	1088	(42.8)
Effective head room	H61	956	(37.6)
Effective T Point head room	H75	961	(37.8)
Max. eff. leg room — accelerator	L34	1086	(42.8)
Sg RP — front to heel	H30	228	(9.0)
Design H-point front travel	L17	172	(6.8)
Shoulder room	W3	1430	(56.3)
Hip room	W5	1313	(51.7)
Upper body opening to ground	H50	1275	(50.2)
Steering Wheel Angle	H18	19.5°	
Back Angle	L40	26.5°	

Rear Compartment

Sg RP Point couple distance	L50	817	(32.2)
Effective head room	H63	961	(37.8)
Effective T Point head room	H76	957	(37.7)
Min. effective leg room	L51	923	(36.3)
Sg RP — second to heel	H31	264	(10.4)
Knee clearance	L48	53	(2.1)
Compartment room	L3	682	(26.9)
Shoulder room	W4	1419	(55.9)
Hip room	W6	1394	(54.9)
Upper body opening to ground	H51	---	

Luggage Compartment

Usable luggage capacity — L(cu. ft.)	V1	456	(16.1)
Liftover height	H195	761	(30.0)

All linear dimensions are in millimeters (inches).

MVMA Specifications Form

Passenger Car

METRIC (U.S. Customary)

Car and Body Dimensions See Key Sheets for definitions

Car Line MONTE CARLO

Model Year 1980

Issued 10/79

Revised (*)

Body Type

SAE Ref. No.	2-Door Sport Coupe
--------------	--------------------

Station Wagon — Third Seat

Shoulder room	W85	
Hip room	W86	
Effective leg room	L86	
Effective head room	H86	
Effective T Point head room	H89	NOT
Seat facing direction	SD1	APPLICABLE

Station Wagon — Cargo Space

Cargo length — open — front	L200	
Cargo length — open — second	L201	
Cargo length — closed — front	L202	
Cargo length — closed — second	L203	
Cargo length at belt — front	L204	NOT
Cargo length at belt — second	L205	APPLICABLE
Cargo width — wheelhouse	W201	
Rear opening width at floor	W203	
Opening width at belt	W204	
Max. rear opening width above belt	W205	
Cargo height	H201	
Rear opening height	H202	
Tail gate to ground height	H250	
Front seat back to load floor height	H197	
Cargo volume index — m ³ (ft. ³)	V2	
Hidden cargo volume — m ³ (ft. ³)	V4	

Hatchback — Cargo Space

Front seat back to load floor height	H197	
Cargo length at front seat		
Back Height	L208	
Cargo length at floor — front	L209	
Cargo volume index — m ³ (ft. ³)	V3	NOT
Hidden cargo volume — m ³ (ft. ³)	V4	APPLICABLE

A printed or computer tape supplement containing additional car and body dimensions and/or drawings (based in part on SAE J1100a "Motor Vehicle Dimensions") may be available from the manufacturer.

All dimensions are in millimeters (inches).

MVMA Specifications Form

Passenger Car
METRIC (U.S. Customary)

Car and Body Dimensions See Key Sheets for definitions

Car Line MONTE CARLO
 Model Year 1980 Issued 10/79 Revised (*) _____

Body Type

2-Door Sport Coupe

Vehicle Fiducial Marks

Fiducial Mark Number *	Define Coordinate Location										
Front	<p>X - Fiducial mark to vertical base grid line-front, measured horizontally from the base grid line to the front fiducial mark located on top of the front seat adjuster mounting bolt.</p> <p>Y - Fiducial mark to centerline of car-front, width measurement made from centerline of car to fiducial mark located on top of the front seat adjuster mounting bolt.</p> <p>Z - Fiducial mark to horizontal base grid line-front, measured vertically from base grid line to front fiducial mark located on top of the front seat adjuster mounting bolt.</p>										
Rear	<p>X - Fiducial mark to vertical base grid line-rear measured horizontally from base grid line to the rear fiducial mark located on rear underbody crossbar.</p> <p>Y - Fiducial mark to centerline of car-rear, width measurement made from centerline of car to fiducial mark located on the rear underbody crossbar.</p> <p>Z - Fiducial mark to horizontal base grid line-rear, measured vertically from base grid line to the rear fiducial mark located on rear underbody crossbar.</p>										
Fiducial Mark Number											
Front	<table style="width: 100%; border-collapse: collapse;"> <tr> <td style="width: 10%; border-right: 1px solid black;">W21</td> <td style="border-bottom: 1px solid black;">564.0 (22.0)</td> </tr> <tr> <td style="border-right: 1px solid black;">L54</td> <td style="border-bottom: 1px solid black;">2761.0 (108.7)</td> </tr> <tr> <td style="border-right: 1px solid black;">H81</td> <td style="border-bottom: 1px solid black;">490.0 (19.3)</td> </tr> <tr> <td style="border-right: 1px solid black;">H161</td> <td style="border-bottom: 1px solid black;">341.49(13.4)</td> </tr> <tr> <td style="border-right: 1px solid black;">H163</td> <td style="border-bottom: 1px solid black;">310.61(12.2)</td> </tr> </table>	W21	564.0 (22.0)	L54	2761.0 (108.7)	H81	490.0 (19.3)	H161	341.49(13.4)	H163	310.61(12.2)
W21	564.0 (22.0)										
L54	2761.0 (108.7)										
H81	490.0 (19.3)										
H161	341.49(13.4)										
H163	310.61(12.2)										
Rear	<table style="width: 100%; border-collapse: collapse;"> <tr> <td style="width: 10%; border-right: 1px solid black;">W22</td> <td style="border-bottom: 1px solid black;">534.0 (21.0)</td> </tr> <tr> <td style="border-right: 1px solid black;">L55</td> <td style="border-bottom: 1px solid black;">5338.0 (210.2)</td> </tr> <tr> <td style="border-right: 1px solid black;">H82</td> <td style="border-bottom: 1px solid black;">617.0 (24.3)</td> </tr> <tr> <td style="border-right: 1px solid black;">H162</td> <td style="border-bottom: 1px solid black;">468.02(18.4)</td> </tr> <tr> <td style="border-right: 1px solid black;">H164</td> <td style="border-bottom: 1px solid black;">425.78(16.8)</td> </tr> </table>	W22	534.0 (21.0)	L55	5338.0 (210.2)	H82	617.0 (24.3)	H162	468.02(18.4)	H164	425.78(16.8)
W22	534.0 (21.0)										
L55	5338.0 (210.2)										
H82	617.0 (24.3)										
H162	468.02(18.4)										
H164	425.78(16.8)										

*Reference — SAE Recommended Practice, J182a, A Motor Vehicle Fiducial Marks — September, 1973.
 All linear dimensions are in millimeters (inches).

MVMA Specifications Form

Passenger Car

METRIC (U.S. Customary)

Car and Body Dimensions See Key Sheets for definitions

Car Line MONTE CARLO

Model Year 1980 Issued 10/79 Revised (*)

Body Type

SAE Ref. No.	2-Door Sport Coupe
--------------	--------------------

Glass

Backlight slope angle	H121	35.5°
Windshield slope angle	H122	59.5°
Tumble-Home	W122	23.5°
Windshield glass exposed surface area — cm ² (in. ²)	S1	8786.3 (1361.9)
Side glass exposed surface area — cm ² (in. ²)	S2	9912.0 (1536.4)
Backlight glass exposed surface area — cm ² (in. ²)	S3	4660.0 (722.3)
Total glass exposed surface area — cm ² (in. ²)	S4	23358.3 (3620.6)
Windshield glass type		Curved Laminated Plate
Side glass type		Curved Tempered Plate
Backlight glass type		Curved Tempered Plate

Lamps and Headlamp Shape *

Height above ground to center of bulb or marker	Headlamp (H127)	Highest **	685.51 (26.98)
		Lowest	685.49 (26.98)
	Tail (H128)	Highest	616.28 (24.27)
		Lowest	---
	Sidemarker	Front	581.40 (22.89)
		Rear	616.35 (24.27)
Distance from C/L of car to center of bulb	Headlamp	Inside	
		Outside **	
	Tail	Inside	
		Outside	
	Directional	Front	
		Rear	
Headlamp Shape		Rectangular	

* Measured at curb mass (weight).

** If single headlamps are used enter here

MVMA Specifications Form
Passenger Car
METRIC (U.S. Customary)

Exterior Car And Body Dimensions — Key Sheet

Exterior Width

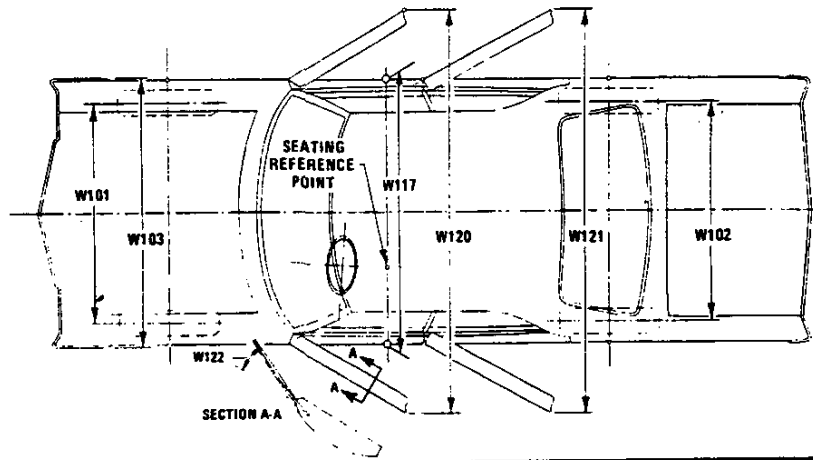

Exterior Length & Height

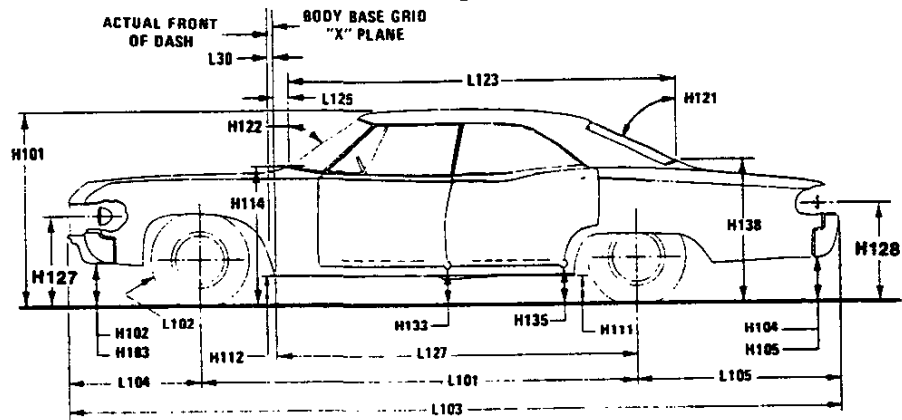

Exterior Ground Clearance

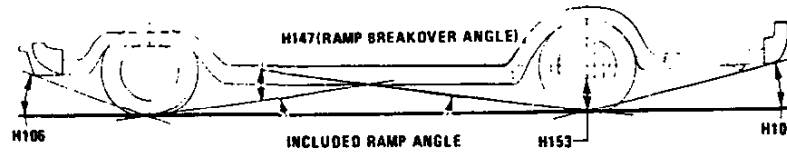

Cargo Space

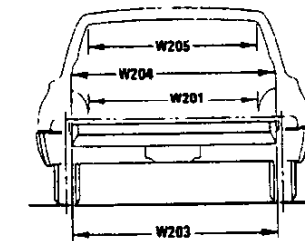
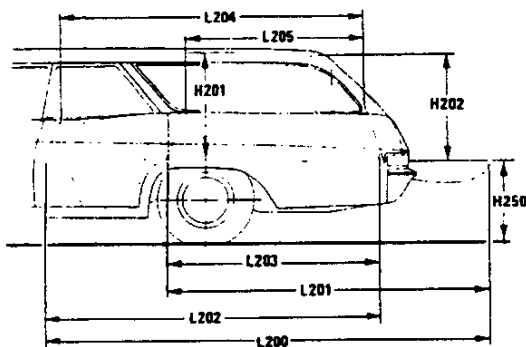

Station Wagon

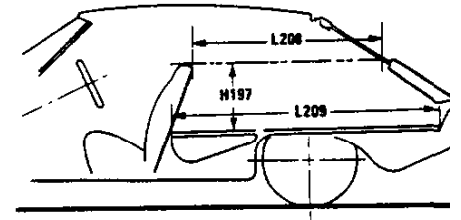

Hatchback

MVMA Specifications Form
Passenger Car
METRIC (U.S. Customary)

Interior Car And Body Dimensions — Key Sheet

Front Compartment

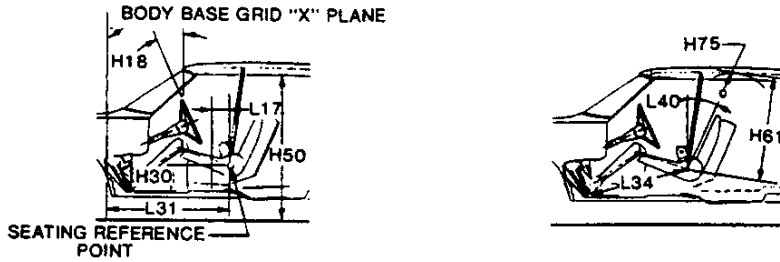

Rear Compartment

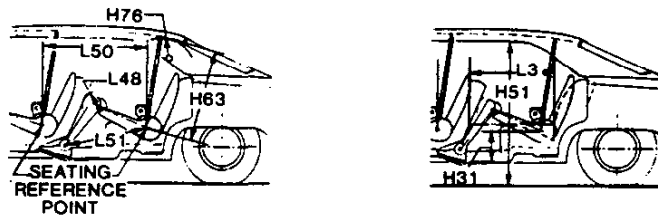

Third Seat

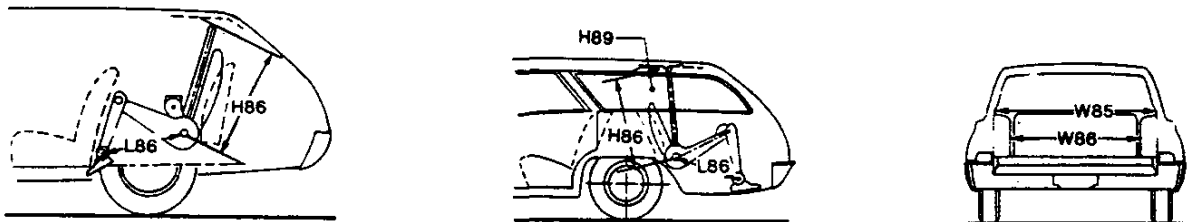

Interior Width

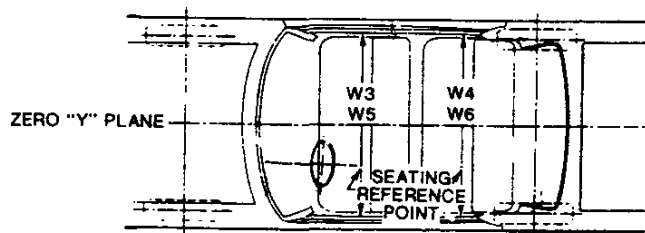

MVMA Specifications Form
Passenger Car
METRIC (U.S. Customary)

Exterior Car And Body Dimensions — Key Sheet
Dimensions Definitions

Seating Reference Point

SEATING REFERENCE POINT means the manufacturer's design reference point which —
 (a) Establishes the rearmost normal design driving or riding position of each designated seating position in a vehicle;
 (b) Has coordinates established relative to the design vehicle structure;
 (c) Simulates the position of the pivot center of the human torso and thigh; and
 (d) Is the reference point employed to position the two dimensional templates described in SAE Recommended Practice J826, "Manikins for Use in Defining Vehicle Seating Accommodations," November 1962.

Width Dimensions

- W101 TREAD — FRONT. The dimension measured between the tire centerlines at the ground.
- W102 TREAD — REAR. The dimension measured between the tire centerlines at the ground. In case of dual wheels, the dimension will be measured to the centerline of tire and wheel assemblies.
- W103 VEHICLE WIDTH. The maximum dimension measured between the widest point on the vehicle, excluding exterior mirrors, flexible mud flaps, marker lamps, but including bumpers, moldings, sheet metal protrusions or dual wheels, if standard equipment.
- W117 BODY WIDTH AT SgRP — FRONT. The dimension measured laterally between the widest points on the body at the SgRP - front, excluding door handles, applied moldings, or appliques.
- W120 VEHICLE WIDTH — FRONT DOORS OPEN. The dimension measured between the widest point on the front doors in maximum hold-open position.
- W121 VEHICLE WIDTH — REAR DOORS OPEN. The dimension measured between the widest point on the rear doors in maximum hold-open position. For vehicles with a rear door on only one side, this dimension is to the zero "Y" plane.
- W122 TUMBLE HOME. STRAIGHT SIDE GLASS. The angle measured from a vertical to the outside surface of the front door glass at the SgRP "X" plane.
 CURVED SIDE GLASS. The angle measured from a vertical to a chord extending from the upper DLO to the lower DLO at the outside surface of the front door glass at the front SgRP "X" plane.

Length Dimensions

- L30 FRONT OF DASH "X" COORDINATE. A minus (-) dimension indicates actual front of dash is forward of the zero "X" plane.
- L101 WHEELBASE (WB). The dimension measured longitudinally between front and rear wheel centerlines. In case of dual rear axles, the dimension shall be to the midpoint of the centerlines of the rear wheels.
- L102 TIRE SIZE. As specified by the manufacturer.
- L103 VEHICLE LENGTH. The maximum dimension measured longitudinally between the foremost point and the rearmost point on the vehicle, including bumper, bumper guards, two hooks and/or rub strips, if standard equipment.
- L104 OVERHAND — FRONT. The dimension measured longitudinally from the centerline of the front wheels to the foremost point on the vehicle including bumper, bumper guards, two hooks and/or rub strips, if standard equipment.
- L105 OVERHAND — REAR. The dimension measured longitudinally from the centerline of the rear wheels; or in the case of dual rear axles, the dimension shall be the midpoint of the centerlines of the rear wheels, to the rearmost point on the vehicle, including rear bumpers, bumper guards, two hooks and rub strips, if standard equipment.

- L123 UPPER STRUCTURE LENGTH. The dimension measured longitudinally from the cowl point to the deck point.
- L127 REAR WHEEL CENTERLINE "X" COORDINATE or in the case of dual rear axles, the coordinate shall be in the midpoint of the distance between the rear axle centerlines.
- L125 COWL POINT "X" COORDINATE.

Height Dimensions

- H101 VEHICLE HEIGHT. The dimension measured vertically from the highest point on the vehicle body to ground.
- H114 COWL POINT TO GROUND. Measured at zero "Y" plane.
- H138 DECK POINT TO GROUND. Measured at zero "Y" plane.
- H112 ROCKER PANEL — FRONT TO GROUND. The dimension measured vertically from the foremost point on the bottom of the rocker panels, excluding flanges, to ground.
- H132 BOTTOM OF DOOR OPEN — FRONT TO GROUND. The dimension measured vertically from the bottom outside corner of the door on the lock pillar side, in maximum hold-open position, to ground.
- H111 ROCKER PANEL — REAR TO GROUND. The dimension measured vertically from the bottom of the rocker or side quarter panel at the front of the rear wheel opening, excluding flanges, to ground.
- H134 BOTTOM OF DOOR OPEN — REAR TO GROUND. The dimension measured vertically from the bottom outside corner of the door on the lock pillar side, in maximum hold-open position, to ground.
- H135 BOTTOM OF DOOR CLOSED — REAR TO GROUND. The dimension measured vertically from the bottom outside corner of the door on the lock pillar side, in maximum closed position, to ground.
- H121 BACKLIGHT SLOPE ANGLE. The angle between the vertical reference line and the surface of backlight at vehicle zero "Y" plane. For curve backlight, the angle is to chord of backlight arc from lower DLO to upper DLO.
- H122 WINDSHIELD SLOPE ANGLE. The angle between the vertical reference line and a chord of the windshield are running from the lower DLO to the upper DLO at the vehicle zero "Y" plane. In the case of wrap over glass, the angle to be measured will be formed by a chord 18.0 in. (457 mm) long, drawn from the lower DLO to the intersecting point on the windshield.
- H127 HEADLAMP TO GROUND — CURB WEIGHT. The dimensional measured vertically from the centerline of the lowest headlamp lens to ground.
- H128 TAILLAMP TO GROUND — CURB WEIGHT. The dimension measured vertically from the centerline of the upper bulb to ground.

Ground Clearance Dimensions

- H102 FRONT BUMPER TO GROUND. The minimum dimension measured vertically from the lowest point on the front bumper to ground, including bumper guards, if standard equipment.
- H103 FRONT BUMPER TO GROUND — CURB WEIGHT. Measured in the same manner as H104.
- H104 REAR BUMPER TO GROUND. The minimum dimension measured vertically from the lowest point on the rear bumper to ground, including bumper guards, if standard equipment.
- H105 REAR BUMPER TO GROUND — CURB WEIGHT. Measured in the same manner as H104.
- H106 ANGLE OF APPROACH. The angle measured between a line tangent to the front tire static loaded radius are the initial point of structural interference forward of the front tire to ground. The limiting structural component shall be designated.

MVMA Specifications Form

Passenger Car

METRIC (U.S. Customary)

Interior Car And Body Dimensions — Key Sheet Dimensions Definitions

- H107 ANGLE OF DEPARTURE. The angle measured between a line tangent to the rear tire static loaded radius and the initial point of structural interference rearward of the rear tire to ground. The limiting component shall be designated.
- H147 REAR BREAKOVER ANGLE. The angle measured between two lines tangent to the front and rear tire static loaded radius and intersecting at a point on the underside of the vehicle which defines the largest ramp over which the vehicle can roll.
- H153 REAR AXLE DIFFERENTIAL TO GROUND. The minimum dimension measured from the rear axle differential to ground.
- H156 MINIMUM RUNNING GROUND CLEARANCE. The minimum dimension measured from the sprung vehicle to ground. Specify location.
- Front Compartment Dimensions**
- PD1 PASSENGER DISTRIBUTION — FRONT.
- L31 SgRP — FRONT "X" COORDINATED.
- H61 EFFECTIVE HEAD ROOM — FRONT. The dimension measured along a line 8 deg. rear of vertical from the SgRP — front to the headline, plus 4.0 in. (102 mm).
- H75 EFFECTIVE T-POINT HEAD ROOM — FRONT. The minimum radius from the T-point to the headlining plus 30 in. (762 mm).
- L34 MAXIMUM EFFECTIVE LEG ROOM — ACCELERATOR. The dimension measured along a line from the ankle pivot center to the SgRP — front plus 10.0 in. (254 mm) measured with right foot on the undepressed accelerator pedal. For vehicles with SgRP to heel (H30) greater than 18 in., the accelerator pedal may be depressed as specified by the manufacturer. If the accelerator is depressed, the manufacturer shall place foot flat on pedal and note the depression of the pedal.
- H30 SgRP — FRONT TO HEEL. The dimension measured vertically from the SgRP — front to the accelerator heel point.
- L17 DESIGN H-POINT — FRONT TRAVEL. The dimension measured horizontally between the design H-point — front in the foremost and rearmost seat trace positions.
- W3 SHOULDER ROOM — FRONT. The minimum dimension measured laterally between the trimmed surfaces on the "X" plane through the SgRP — front within the belt line and 10.0 in. (254 mm) above the SgRP — front.
- W5 HIP ROOM — FRONT. The minimum dimension measured laterally between the trimmed surfaces on the "X" plane through the SgRP — front within 1.0 in. (25 mm) below and 3.0 (76 mm) above the SgRP — front and 3.0 (76 mm) fore and aft of the SgRP — front.
- H150 UPPER BODY OPENING TO GROUND — FRONT. The dimension measured vertically from the trimmed body opening to the ground on the SgRP — front "X" plane.
- H18 STEERING WHEEL ANGLE. The angle measured from a vertical to the surface plane of the steering wheel.
- L40 BACK ANGLE — FRONT. The angle measured between a vertical line through the SgRP — front and the torso line. If the seatback is adjustable, use the normal driving and riding position specified by the manufacturer.
- Rear Compartment Dimensions**
- PD2 PASSENGER DISTRIBUTION — SECOND.
- L50 SgRP COUPLE DISTANCE. The dimension measured horizontally from the driver SgRP — front to the SgRP — second.
- H63 EFFECTIVE HEAD ROOM — SECOND. The dimension measured along a line 8 deg. rear of vertical from the SgRP to the headlining, plus 4.0 in. (102 mm).
- H76 EFFECTIVE T-POINT HEAD ROOM — SECOND. Measured in the same manner as H75.
- L51 MINIMUM EFFECTIVE LEG ROOM — SECOND. The dimension measured along a line from the ankle pivot center to the SgRP — second plus 10.0 in. (254 mm).
- H31 SgRP — SECOND TO HEEL. The dimension measured vertically from the SgRP — second to the two dimensional device heel point on the depressed floor covering.
- L48 KNEE CLEARANCE — SECOND. The minimum dimension measured from the knee pivot to the back of front seatback minus 2.0 in. (51 mm).
- L3 COMPARTMENT ROOM — SECOND. The dimension measured horizontally from the back of front seat to the front of the second seatback at a height tangent to the top of the second seat cushion.
- W4 SHOULDER ROOM — SECOND. The minimum dimension measured laterally between trimmed surfaces on the "X" plane through the SgRP — second within 10.0-16.0 in. (254-406 mm) above the SgRP — second.
- W6 HIP ROOM — SECOND. Measured in the same manner as W5.
- H51 UPPER BODY OPENING TO GROUND — SECOND. The dimension measured vertically from the trimmed body opening to the ground on the "X" plane 13.0 in. (330 mm) forward of the SgRP — second.
- Luggage Compartment Dimensions**
- V1 USABLE LUGGAGE CAPACITY — Total of volumes of individual pieces of standard luggage set plus H-boxes stowed in the luggage compartment in accordance with the procedure described in paragraph 8.2 of SAE-J1100a.
- H195 LIFTOVER HEIGHT. The dimension measured vertically from the luggage compartment lower opening at the zero "Y" plane to ground.
- Station Wagon — Third Seat Dimensions**
- PD3 PASSENGER DIRECTION — THIRD
- W85 SHOULDER ROOM — THIRD. Measured in the same manner as W5.
- W86 HIP ROOM — THIRD. Measured in the same manner as W5.
- L86 EFFECTIVE LEG ROOM — THIRD. The dimension measured along a line from the ankle pivot center to the SgRP — third plus 10.0 in. (254 mm).
- H86 EFFECTIVE HEAD ROOM — THIRD. The dimension, measured along a line 8 deg. from the SgRP — third to the headlining rear of vertical plus a constant of 4.0 in. (102 mm).
- H89 EFFECTIVE T-POINT HEAD ROOM — THIRD. Measured in the same manner as H75.
- Station Wagon — Cargo Space Dimensions**
- L200 CARGO LENGTH — OPEN — FRONT. The minimum dimension measured longitudinally from the back of the front seatback at the height of the undepressed floor covering to the rearmost point on the undepressed floor covering on the open tailgate or cargo surface if the rear closure is a conventional door type tailgate, at the zero "Y" plane.
- L201 CARGO LENGTH — OPEN — SECOND. The dimension measured longitudinally from the back of the second seatback at the height of the undepressed floor covering on the open tailgate or cargo floor surface if the rear closure is a conventional door type tailgate, at the zero "Y" plane.
- L202 CARGO LENGTH — CLOSED — FRONT. The minimum dimension measured horizontally from the back of the front seat at the height of the undepressed floor covering to the rearmost point on the undepressed floor covering on the closed tailgate or taildoor for station wagons, trucks and mpv's at the zero "Y" plane.

MVMA Specifications Form

Passenger Car

METRIC (U.S. Customary)

Interior Car And Body Dimensions — Key Sheet Dimensions Definitions

<p>L 203 CARGO LENGTH — CLOSED — SECOND. The dimension measured horizontally from the back of the second seat at the height of the undepressed floor covering to the rearmost point on the undepressed floor covering on the closed tailgate or taildoor for station wagons, trucks and mpv's at the zero "Y" plane.</p> <p>L 204 CARGO LENGTH AT BELT — FRONT. The minimum dimension measured horizontally from the back of the front seatback at the seatback top to the foremost normal surface of the closed tailgate or inside surface of the cab back panel at the height of the belt, on the zero "Y" plane.</p> <p>L 205 CARGO LENGTH AT BELT — SECOND. The minimum dimension measured horizontally from the back of the second seatback at the seatback top to the foremost normal surface of the closed tailgate at the height of the belt, on the zero "Y" plane.</p> <p>W 201 CARGO WIDTH — WHEELHOUSE. The minimum dimension measured laterally between the trimmed wheelhousings at floor level. For any vehicle not trimmed, measure the sheet metal.</p> <p>W 203 REAR OPENING WIDTH AT FLOOR. The minimum dimension measured laterally between the limiting interferences of the rear opening at floor level.</p> <p>W 204 REAR OPENING WIDTH AT BELT. The minimum dimension measured laterally between the limiting interferences of the rear opening at belt height or top of pick up box.</p> <p>W 205 REAR OPENING WIDTH ABOVE BELT. The minimum dimension measured laterally between the limiting interferences of the rear opening above the belt height.</p> <p>H 201 CARGO HEIGHT. The dimension measured vertically from the top of the undepressed floor covering to the headlining at the rear wheel "X" coordinated on the zero "Y" plane.</p> <p>H 202 REAR OPENING HEIGHT. The dimension measured vertically from the top of the undepressed floor covering to the upper trimmed opening on the zero "Y" plane with rear door fully open.</p> <p>H 250 TAILGATE TO GROUND (CURB WEIGHT). The dimension measured vertically from the top of the undepressed floor covering on the lowered tailgate to ground on the zero "Y" plane.</p>	<p>V 2 STATION WAGON Measured in inches: $\frac{W4 \times H201 \times L204}{1728} = \text{Ft.}^3$ Measured in mm: $\frac{W4 \times H201 \times L204}{10^9} = \text{m}^3 \text{ (cubic meter)}$</p> <p>V 4 HIDDEN CARGO VOLUME. As specified by the manufacturer.</p> <p>Hatchback — Cargo Space Dimensions All hatchback cargo dimensions are to be taken with the front seat in full down and rear position, and the rear seat folded down. The hatchback door is in the closed position. (For electrically adjusted seats, see the manufacturer's specifications for Design "H" Point).</p> <p>H 197 FRONT SEATBACK TO LOAD HEIGHT. The dimension measured vertically from the horizontal tangent to the top of the seatback to the undepressed floor covering.</p> <p>L 208 CARGO LENGTH AT FRONT SEATBACK HEIGHT. The minimum horizontal dimension from the "X" plane tangent to the rearmost surface of the driver's seatback to the inside limiting interference of the hatchback door on the vehicle zero "Y" plane.</p> <p>L 209 CARGO LENGTH AT FLOOR — FRONT — HATCHBACK. The minimum horizontal dimension measured at floor level from the rear of the front seatback to the normal limiting interference of the hatchback door on the vehicle zero "Y" plane.</p> <p>V 3 HATCHBACK. Measured in inches: $\frac{\frac{L208 + L209}{2} \times W4 \times H197}{1728} = \text{Ft.}^3$ Measured in mm: $\frac{\frac{L208 + L209}{2} \times W4 \times H197}{10^9} = \text{m}^3 \text{ (cubic meter)}$</p>
---	--

MVMA Specifications Form

Passenger Car

METRIC (U.S. Customary)

Index

Subject	Page No.	Subject	Page No.
Alternator	12	Lamps and Headlamp Shape	30
Automatic Transmission	16	Legroom	27, 28
Axis, Steering	20	Lengths — Car and Body	26
Axle, Rear	2, 16	Lifters, valve	6
Battery	12	Linings — Clutch, Brake	15, 19
Bearings, Engine	4, 5, 7	Lubrication	7, 15, 16, 17
Belts — Fan, Generator, Water Pump	9	Luggage Compartment	27
Brakes — Parking, Service	18, 19	Mass	27, 28
Camber	20	Models	1
Camshaft	5	Motor, Starting	15
Capacities		Muffler	10
Cooling System	12	Passenger Capacity	1
Fuel Tank	8	Passenger Mass Distribution	24
Lubricants		Piston Pins & Rings	3, 4
Engine Crankcase	7	Pistons	3, 4
Transmission	15, 16	Power Brakes	19
Rear Axle	16	Power Engine	2
Car Models	1	Power Steering	20
Car and Body Dimensions		Power Teams	2
Width	26	Propeller Shaft, Universal Joints	17
Length	26	Pumps — Oil, Fuel	7, 8
Height	26	Water	9
Ground Clearance	26	Radiator — Cap, Hoses	9
Front Compartment	27	Ratios — Axle	2, 16
Rear Compartment	27	Compression	2, 3
Luggage Compartment	27	Steering	20
Station Wagon — Third Seat	28	Transmission	15, 16
Station Wagon — Cargo Space	28	Rear Axle	2, 16
Hatchback — Cargo Space	28	Regulator — Generator	12
Carburetor	2, 8, 11	Rims	18
Caster	20	Rings, Piston	4
Choke, Automatic	8	Rods — Connecting	4
Clutch — Pedal Operated	15	Seats	27
Coil, Ignition	14	Shock Absorbers, Front & Rear	2
Connecting Rods	4	Spark Plugs	14
Convenience Equipment	23	Speedometer	14
Cooling System	9	Springs — Front & Rear Suspension	21
Crankshaft	5	Stabilizer (Sway Bar) — Front & Rear	21
Cylinders and Cylinder Head	3	Starting System	12
Dimension Definitions		Steering	26
Key Sheet — Exterior	31, 33	Suppression — Ignition, Radio	14
Key Sheet — Interior	32, 34, 35	Suspension — Front & Rear	21
Distributor — Ignition	13	Tail Pipe	7
Electrical System	12, 13, 14	Theft Protection	23
Emission Controls	10, 11	Thermostat, Cooling	9
Engine		Timing — Valve, Ignition	6, 13
Bore, Stroke, Type	3	Tires	18
Compression Ratio	2, 3	Toe in	20
Displacement	2	Torque Converter	16
Firing Order, Cylinder Numbering	3	Torque — Engine	2
General Information, Power & Torque	2, 3	Transmission — Types	2, 8, 15, 16
Identification Number Location	22	Transmission — Automatic	2, 8, 15, 16
Lubrication	7	Transmission — Manual	2, 8, 15
Power Teams	2	Transmission — Ratios	15, 16
Exhaust System	7	Tread	26
Equipment Availability	24	Trunk Cargo Load	1
Fan, Cooling	9	Trunk Luggage Capacity	27
Fiducial Marks	29	Turning Diameter	20
Filters — Engine Oil, Fuel System	7, 8	Unitized Construction	22
Frame	22	Universal Joints, Propeller Shaft	17
Front Suspension	21	Valves — Intake & Exhaust	6
Fuel, Fuel Pump, Fuel System	3, 8, 11	Vehicle Identification Number	22
Fuel Injection	8	Voltage Regulator	12
Generator and Regulator	12	Water Pump	9
Glass	30	Weights	24, 25
Headroom — Body	27, 28	Wheel Alignment	20
Heights — Car and Body	26	Wheelbase	26
Horns	14	Wheels & Tires	18
Horsepower — Brake	2	Wheel Spindle	2
Ignition System	13, 14	Widths — Car and Body	2
Inflation — Tires	18	Windshield	30
Instruments	14	Windshield Wiper and Washer	14
Kingpin (Steering Axis)	20		