

Chevrolet

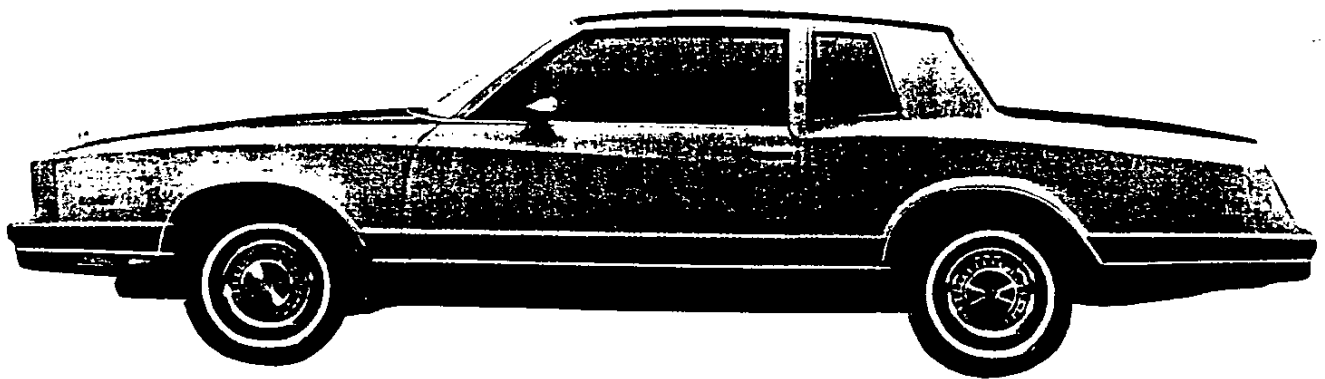

1982 Monte Carlo



MONTE CARLO

Sportiness and Elegance on a Six-Passenger Scale

Monte Carlo for 1982 continues the contemporary aerodynamic silhouette, elegant styling and road manners that led to an increase in its appeal last year.

Consider styling. This year it brings a new finely textured grille to accent its sweeping lines and enticing angles. Inside, a fold-down center armrest is standard, with 55-45 seat design optional. A plush Custom Interior is available for your special customers.

Consider fuel efficiency. For the first time, diesel engines are optional in all states. No spark plugs. No distributor or carburetor to service.

And no catalytic converter is required with a diesel, either.

Even without a diesel engine, Monte Carlo is efficient with its standard 3.8 Liter V6 gasoline engine and new low-drag front disc brakes. Power steering, power brakes, automatic transmission and anti-corrosion treatments in every critical area.

So consider what Monte Carlo has to offer. Dramatic eye appeal. Impressive economy. And superb engineering. In total, Monte Carlo for 1982 is designed to create satisfied owners.

See EPA Section for all mileage engine details.

NEW FEATURES

- Diesel engines now available in all states.
- New finely textured grille.
- Right-hand outside rearview mirror.
- Padded landau-style vinyl roof will be optional.
- Fold-down center armrest in standard interior.
- New Custom Interior optional.
- Low-drag front disc brakes.
- Column-mounted turn signal dimmer switch now also includes wiper washer controls.
- Dual-nozzle fluidic windshield washer system.

Vertical dashed line

1982 MONTE CARLO

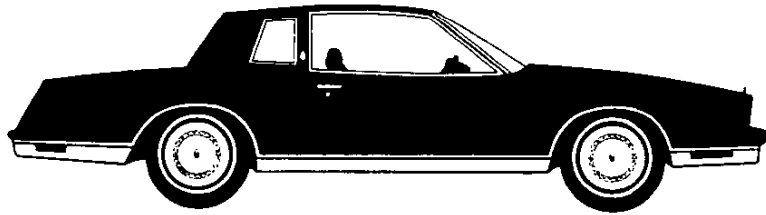

Sport Coupe

Monte Carlo	Model No.
Sport Coupe	1GZ37

Index

Monte Carlo Value Features for 1982	2-4	Color and Trim Combinations. Vinyl Roof Covers.
Monte Carlo Sport Coupe	5	Striping, Moldings
Standard Interior Features	6	Optional Equipment
Custom Interior Features	7	Body Features
Instrument Panel Features	8	Power Teams/Dimensions/Specifications
Seat and Door Trim	9	Color and Fabric Selector

Also see Value Features and Option Features sections for additional details.

See Dealer Order Guide for latest available information.

Monte Carlo/1

1982 MONTE CARLO VALUE FEATURES

	Monte Carlo Sport Coupe
POWER TEAMS/CHASSIS/MECHANICAL	
3.8 L 2-Bbl. V6 (229 CID) (Fed.)	S
3.8 L 2-Bbl. V6 (231 CID) (Cal.)	S
4.4 L 2-Bbl. V8 (267 CID) (Fed.)	EC
5.0 L 4-Bbl. V8 (305 CID) (Cal.)	EC
5.7 L Diesel V8 (350 CID)	EC
Automatic transmission	S
Power steering	S
Power disc/rear drum brake system	S
Vented front disc brake rotors and finned rear brake drums	S
Disc brake audible wear sensors	S
P195/75R-14 steel-belted radial-ply tires	S
14" x 6" wheels	S
Coolant recovery system	S
Inside hood release	S
Concealed dual-speed electric windshield wipers	S
Dual-mode flow-thru ventilation system	S
Delco Freedom II battery with sealed side terminals	S
Delcotron generator with built-in solid-state regulator	S
Front stabilizer bar	S
Full Coil suspension system	S
Independent coil-spring spherical joint front suspension (short and long arm type) with low-friction non-metallic spherical joint liners and built-in anti-dive control	S
Visible ball joint wear indicators on front suspension lower control arms	S
Four-link-type rear suspension with dual bias-mounted upper control arms and parallel-mounted lower control arms	S
Direct double-acting sealed-unit hydraulic shock absorbers	S
Steel roof panel with double-flanged channel-crossed reinforcing bows	S
Box-section design roof rails, windshield and rear window headers, door and roof pillars	S
High-strength double-walled cowl unit-welded to instrument panel, floor, and dash panel	S
All-welded heavy-gage steel body construction including cowl, roof, underbody and body panels	S
Double panel door, hood and deck lid	S
Counterbalanced hood, deck lid	S
Bolt-on front-end sheet metal cushion-mounted to frame and radiator support assembly	S
Full perimeter frame	S
Fourteen-cushion body mounting system	S
Body-color bumpers with high-strength reinforcements	S

	Monte Carlo Sport Coupe
POWER TEAMS/CHASSIS/MECHANICAL (Cont'd)	
Front and rear inner fenders	S
Heavily ribbed and formed underbody with transverse stiffeners welded to underbody and body sills	S
Long recommended service intervals for oil change, oil filter, spark plugs, chassis lubrication and automatic transmission fluid	S
EXTERIOR	
Bright windshield reveal molding	S
Quad rectangular headlamps	S
Dual bright outside rearview mirrors	S
Chrome-plated grille	S
Chrome-plated headlamp bezels	S
Bright roof drip moldings	S
Bright lower body side moldings	S
Stand-up hood ornament	S
Body pin striping	EC
Full wheel covers	S
Aluminum wheels	EC
Wire wheel covers	EC
Wheel opening moldings	S
Bright quarter window reveal molding	S
Bright deck lid and end cap moldings	S
Bright tail lamp trim	S
Recessed rear license plate	S
Deck lid lock cover	S
INTERIOR	
Full-width front seat with folding armrest	S
Molded lower door panels with padded armrests and carpeted lower section	S
Vinyl door pull straps	S
Day/night rearview mirror	S
Center dome light	S
Color-keyed steering wheel, column, and instrument panel	S
Color-keyed seat and shoulder belts	S
Speedometer calibrated in MPH and KPH (kilometers per hour)	S
Glove compartment lock	S
Instrument panel courtesy, ashtray, and glove compartment lights	S
Dual horns	S
Cigarette lighter	S
One-piece cloth headlining over thick foam padding	S
Color-keyed one-piece cut-pile carpeting	S
Luggage compartment mat	S
High-level acoustical insulation	S

S — Standard EC — Extra Cost

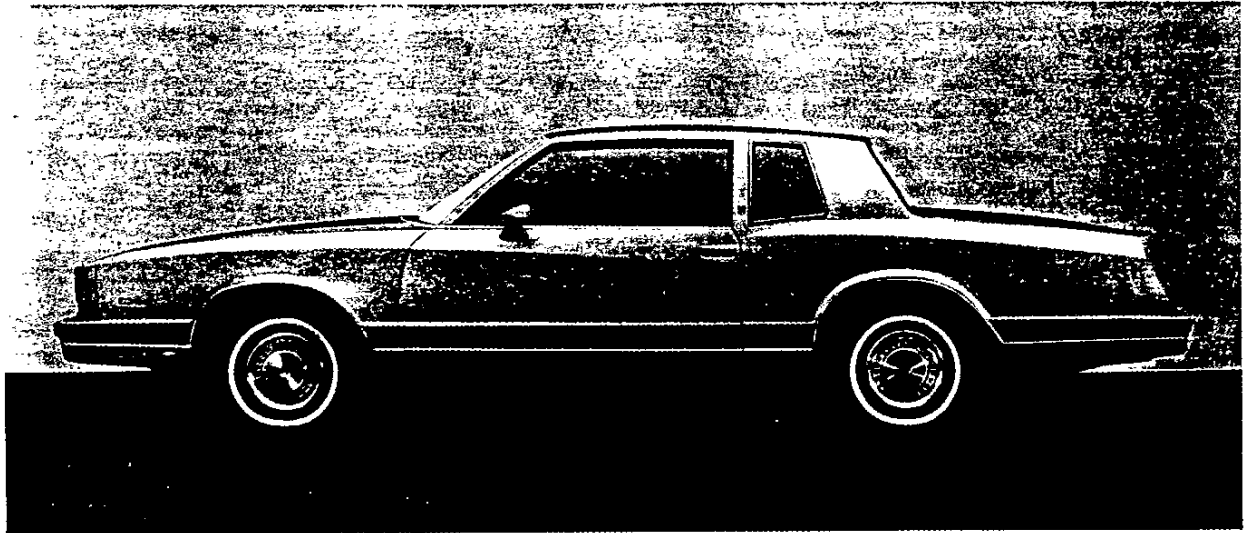

Monte Carlo Sport Coupe with Aerodynamic Styling

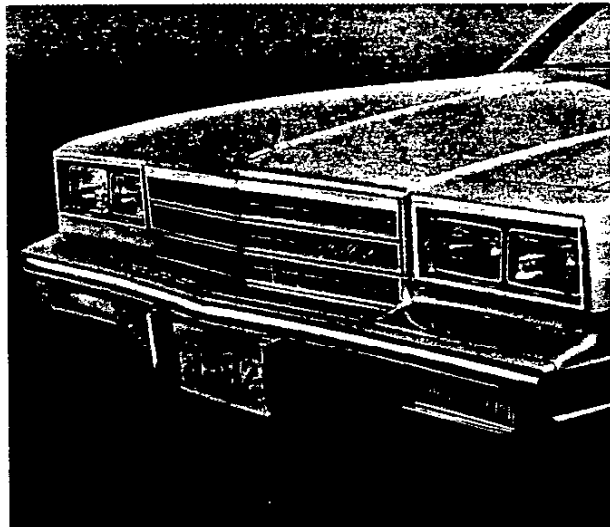

New Grille Styling

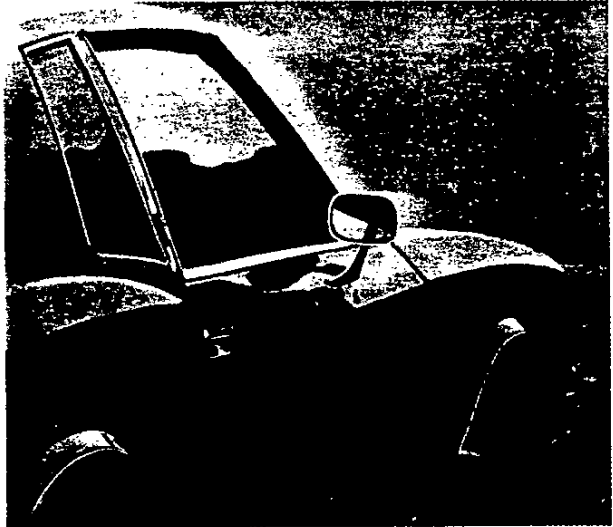

Twin Chrome Outside Mirrors *Standard*

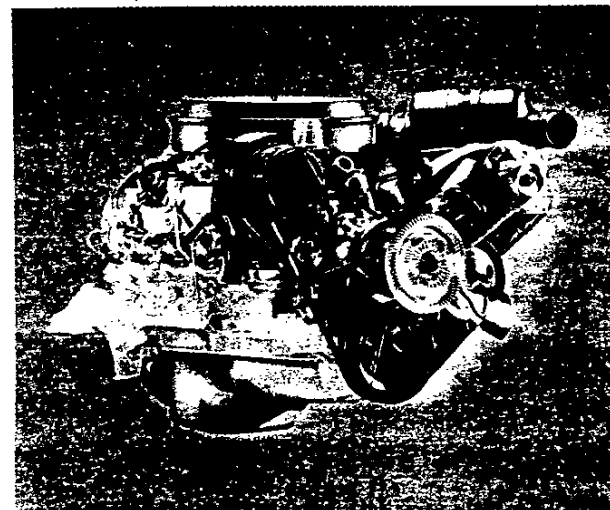

5.7 Liter Diesel V8 Engine Available

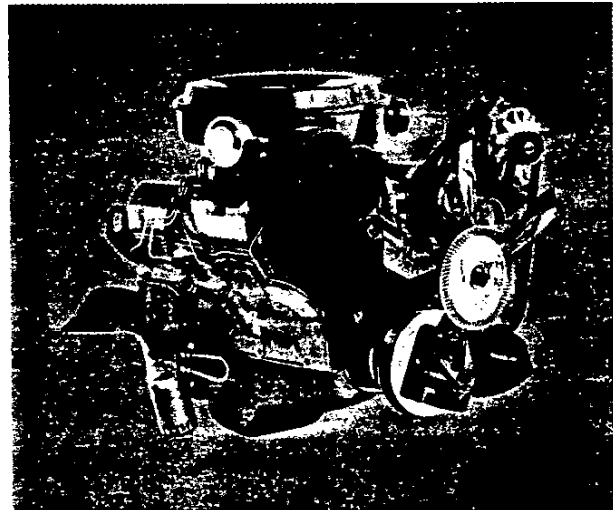

4.3 Liter Diesel V6 Engine Available

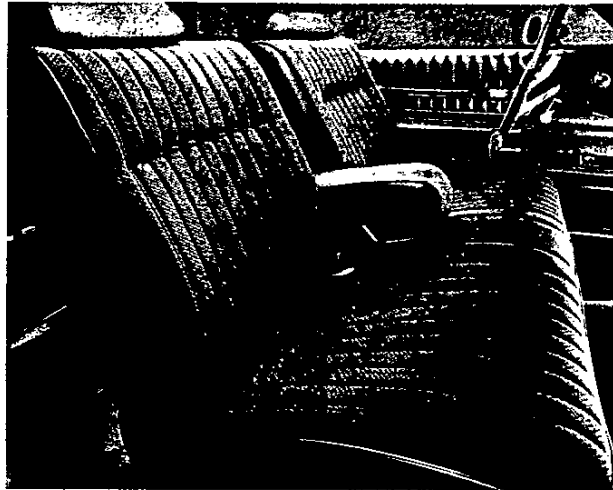

Luxurious Cloth Seats with Front Folding Armrest *Standard*

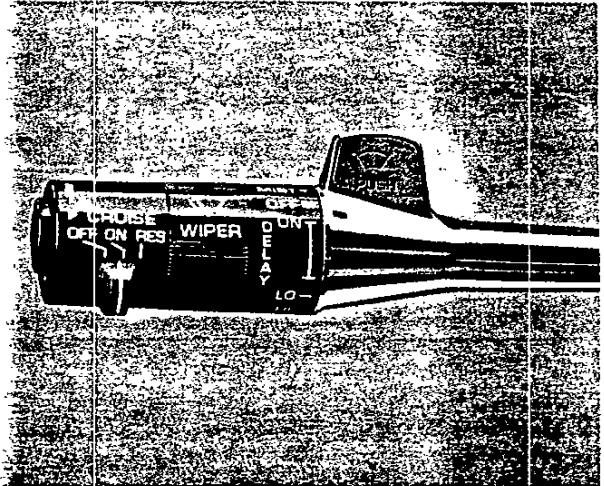

Multi-Function Turn Signal/Dimmer/Wiper/Washer Switch

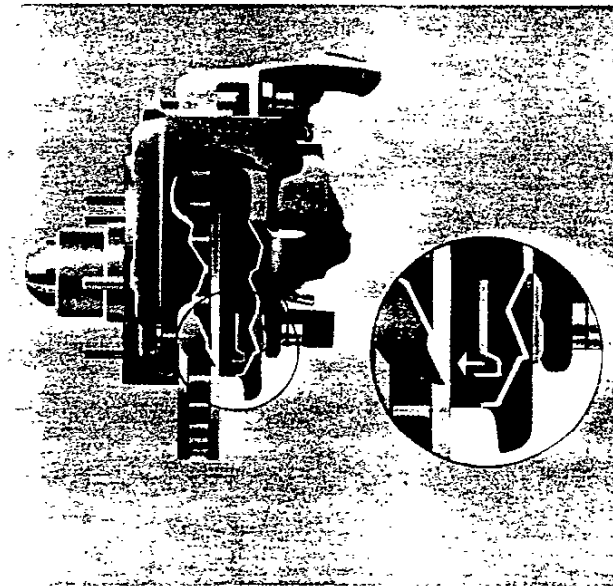

Low-Drag Front Disc Brakes with Audible Wear Sensors

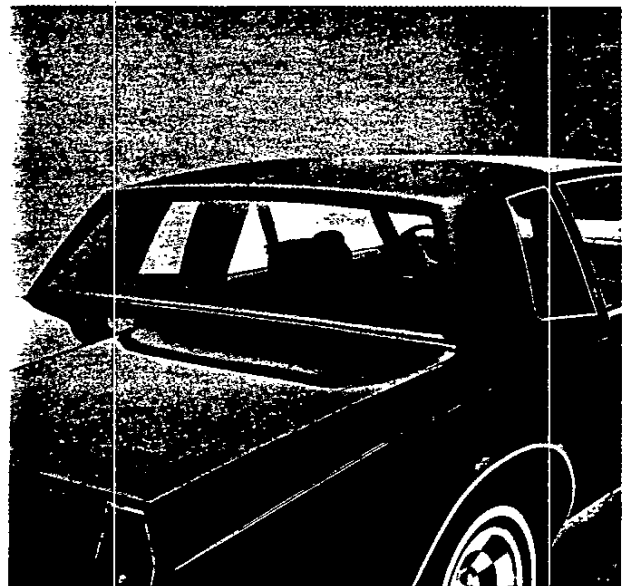

Padded Landau Vinyl Roof Available



Removable Glass Roof Panels Available



Optional Aluminum Wheels

MONTE CARLO

Sport Coupe

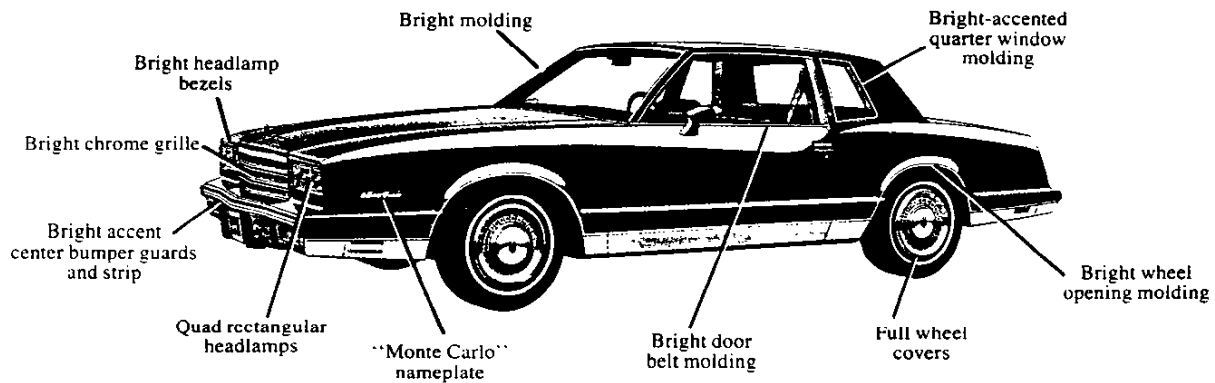
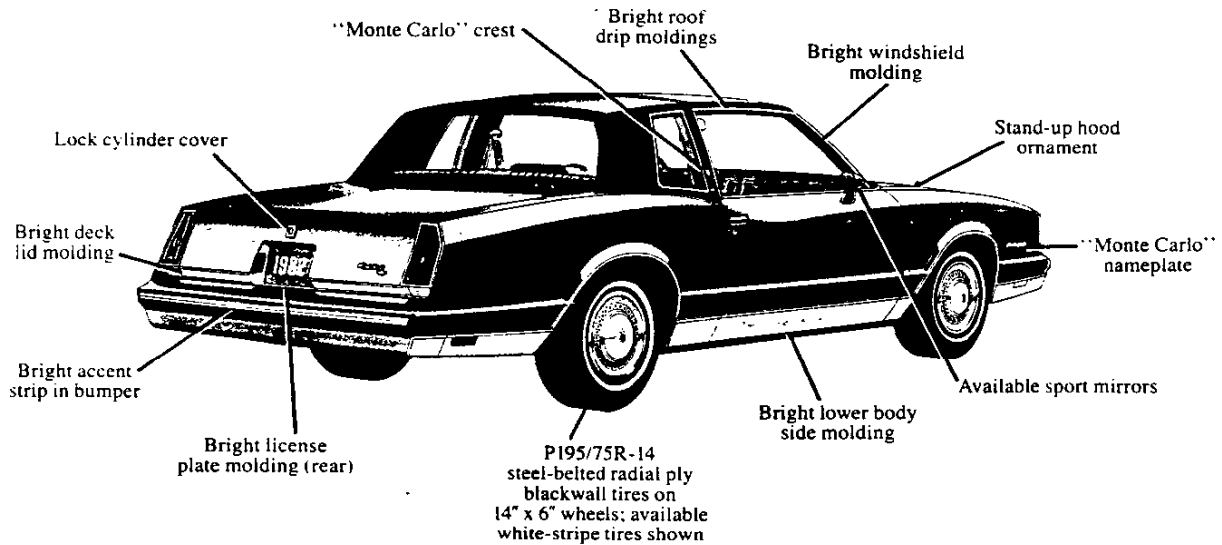

Standard Monte Carlo Wheel Cover



Available Aluminum Wheel (RPO N90)



Available Rally Wheel (RPO Z17)

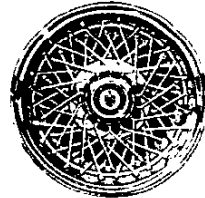

Available Wire Wheel Cover (RPO N95)

INTERIOR FEATURES

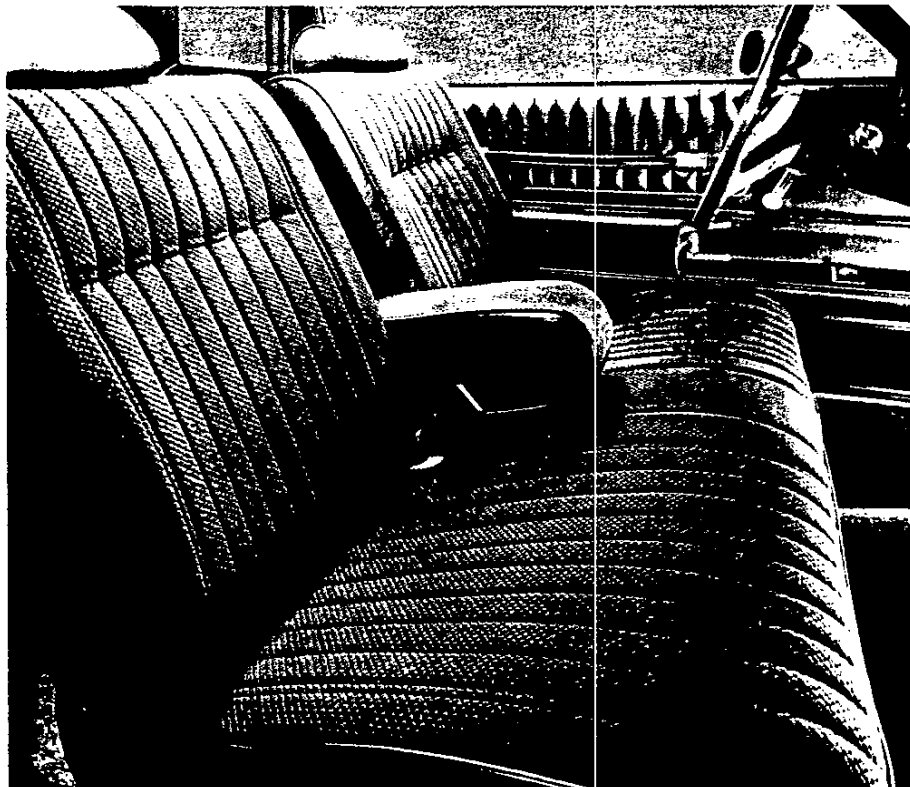

Monte Carlo Standard Interior

STANDARD INTERIOR FEATURES

Monte Carlo

Full-width front and rear seats in cloth	S
Full-width front and rear seats in vinyl	EC
Fold-down front center armrest	S
55/45 front seat in standard trim	EC
Molded full-foam seat construction	S
Color-keyed seat and shoulder belts	S
Adjustable head restraints	S
Inertia-type folding seat-back locks	S
Upholstered, vertically ribbed upper door panels	S
Large vinyl door pull straps	S
Integral padded armrests	S
Carpeted lower door panels	S
Automatic dome lamp switches on doors	S
Instrument panel courtesy lamps	S
Glove compartment lock and lamp	S
Luxurious cloth, foam-backed headlining	S
Quiet Sound Group acoustical insulation package	S
Color-keyed, molded-back one-piece carpeting	S
Cigarette lighter and ashtray lamp	S
Rear seat ashtray	S
Quartz electric clock	EC
Day/night rearview mirror	S
Inertia-type folding seat-back locks	S

S — Standard EC — Extra Cost

INTERIOR FEATURES



Monte Carlo Custom Interior

CUSTOM INTERIOR FEATURES (Optional at Extra Cost)

- Custom full-width seats with fixed-pillow design
- Fold-down center armrest
- Bright front seat end panels
- Custom door trim with cloth insert and simulated wood-grain molding
- Smooth-padded upper door panel trim
- Quiet Sound Group acoustical insulation package
- Plus standard Monte Carlo features:
 - Integral padded armrests
 - Carpeted lower door panels
 - Large, vinyl door pull straps
 - Molded full-foam seat construction
 - Color-keyed seat and shoulder belts
 - Adjustable head restraints
 - Inertia-type folding seat-back locks
 - Luxurious cloth, foam-backed headlining
 - Color-keyed, molded-back one-piece carpeting
 - Automatic dome lamp switches on doors
 - Instrument panel courtesy lamps
 - Glove compartment lock and lamp
 - Cigarette lighter and ashtray lamp
 - Rear seat ashtray
 - Day/night rearview mirror

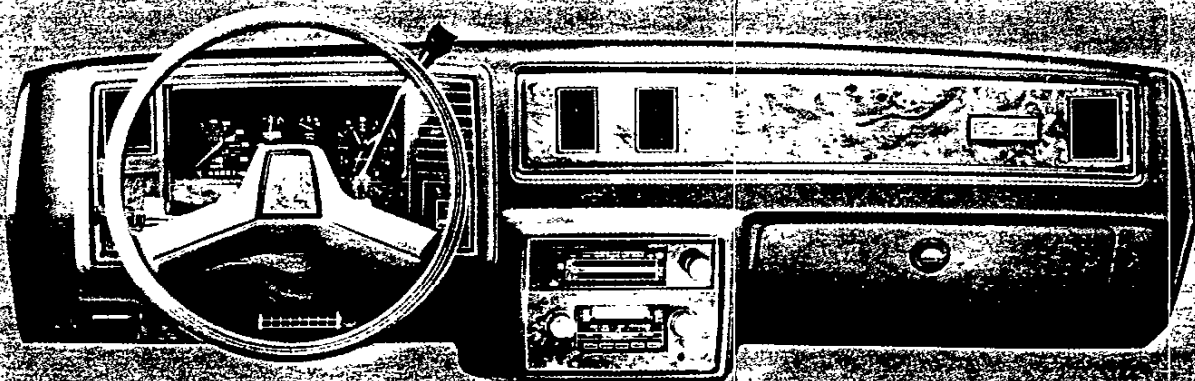

Monte Carlo Instrument Panel

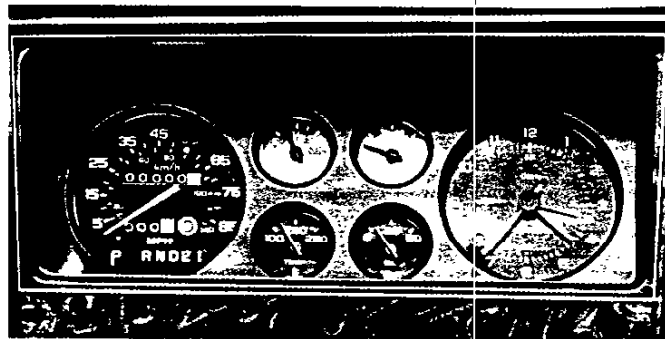

Available Gage Package (RPO UF7)

INSTRUMENT PANEL FEATURES

Monte Carlo

Color-keyed instrument panel, steering wheel and column	S
Simulated wood-grain on panel pad and instrument cluster	S
Column-mounted turn signal/headlamp dimmer/wiper/washer switch	S
Cigarette lighter	S
Monte Carlo nameplate and crest on panel pad	S
Gage Package includes voltmeter, temperature, oil pressure gages and clock	EC
85 mph/140 kph (kilometers per hour) speedometer	S
Quartz electric clock	EC
Soft-rim steering wheel with simulated wood-grain applique	S
Ashtray lamp	S
Dual-speed electric windshield wipers	S
Glove compartment lamp	S
Instrument panel courtesy lamps	S
Ashtray lamp	S
Inside hood release	S
Glove compartment lock and lamp	S
S — Standard EC — Extra Cost	

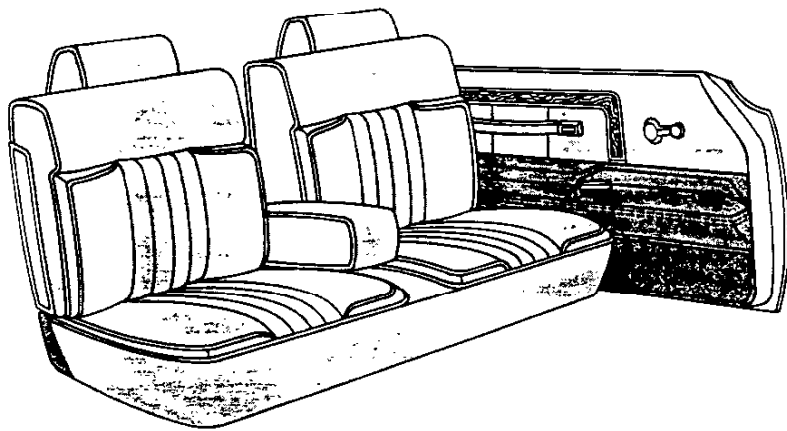

Monte Carlo optional Custom Interior in cloth trim with bench seat and front fold-down armrest. Custom door and quarter trim panels are included.

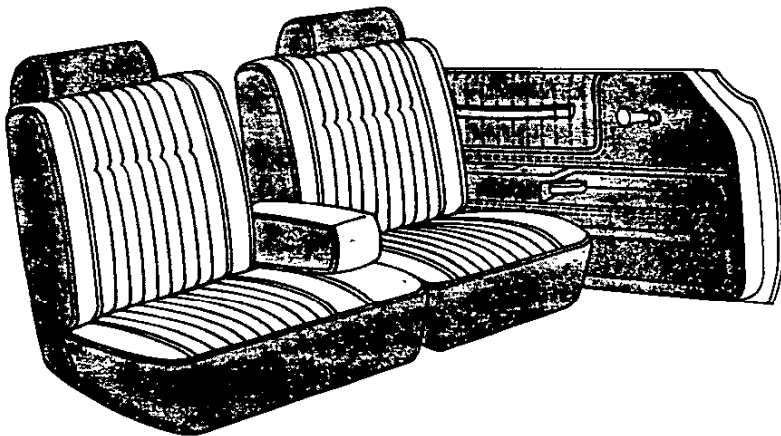

Monte Carlo standard cloth trim with optional 55/45 split front seat and fold-down center armrest. Vinyl trim is available.

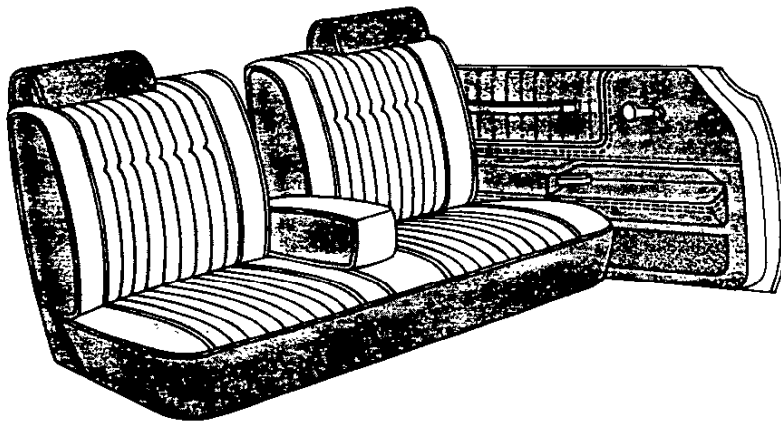

Monte Carlo standard cloth trim with bench seat and front fold-down armrest. Vinyl trim is available.



See Dealer Order Guide for latest available information.

Monte Carlo/9

COLOR AND TRIM COMBINATIONS

INTERIOR COLORS		DK. BLUE	CAMEL	SILVER GRAY	JADE	REDWOOD
MONTE CARLO						
Sport Coupe Custom (Bench)	Cloth	X	X		X	X
Sport Coupe (55'45)	Cloth	X	X			X
	Vinyl	X	X	X		X
Sport Coupe (Bench)	Cloth	X	X			X
	Vinyl	X	X	X		X

EXTERIOR COLORS	CODE	INT./EXT. COMB.	VINYL ROOF	INT./EXT. COMB.	VINYL ROOF	INT./EXT. COMB.	VINYL ROOF	INT./EXT. COMB.	VINYL ROOF	INT./EXT. COMB.	VINYL ROOF
WHITE	11	X	WW.DD	X	WW.CC	X	WW.QQ	X	WW.GG	X	WW.FF
SILVER (MET.)	16	X	DD			X	QQ	X	QQ	X	FF
LIGHT BLUE (MET.)	21	X	DD								
DARK BLUE (MET.)	29	X	DD	X	DD.CC	X	DD.QQ				
LIGHT JADE (MET.)	45							X	GG		
DARK JADE (MET.)	49			X	CC	X		X	GG		
BEIGE	63	X	UU.DD	X	UU					X	UU
LIGHT BROWN (MET.)	68			X	CC						
LIGHT REDWOOD (MET.)	72									X	FF
REDWOOD (MET.)	77			X	FF.CC					X	FF
SILVER GRAY	80	X	DD.QQ			X	QQ			X	QQ
CHARCOAL (MET.)	84					X	QQ	X	QQ		

CUSTOM TWO-TONE (RPO D84) COLORS											
WHITE SILVER GRAY						X	QQ				
LIGHT BLUE/DARK BLUE (METS.)		X	DD								
DARK JADE/LIGHT JADE (METS.)								X	GG		
BEIGE DARK BLUE (MET.)		X	DD								
BEIGE REDWOOD (MET.)										X	FF
LIGHT REDWOOD/REDWOOD (METS.)										X	FF

STANDARD INTERIOR TRIM GUIDE • Cloth seat trim and bench seats standard • All other combinations are available options, including Vinyl trim on bench seat.

Custom Two-Tone (RPO D84)



White Silver Gray
accent color



Light Blue (Metallic)
Dark Blue (Metallic)
accent color



Dark Jade (Metallic)
Light Jade (Metallic)
accent color



Beige Dark Blue
(Metallic) accent color



Beige Redwood
(Metallic) accent color

Light Redwood (Metallic)
Redwood (Metallic)
accent color

Pin Stripping Colors



Blue



Gold

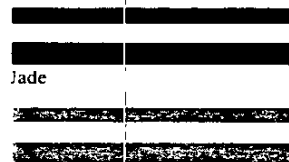

Jade



Redwood

Charcoal

Beige

Silver

Custom Two-Tone (RPO D84)

Two-Tone exterior paint with accent color on hood, roof and around side windows. Color-keyed pin striping separates the two colors. Available in choice of six combinations.

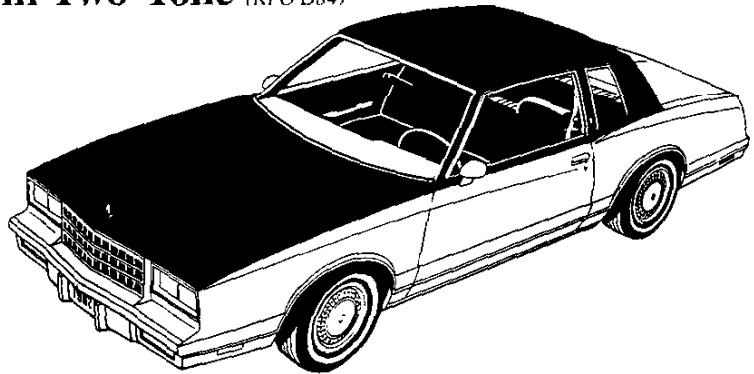

Body Pin Striping (RPO D85)

On body sides, fenders, deck lid and hood. Available in seven dual-stripe colors keyed to exterior/interior colors.

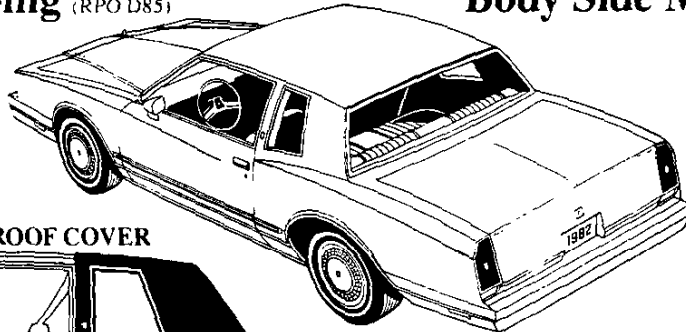

Body Side Moldings (RPO BW2)

Bright with insert in black or silver gray keyed to interior/exterior colors.

VINYL ROOF COVER

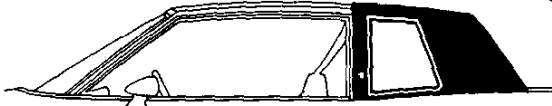

Padded Landau vinyl roof. Available in seven colors.

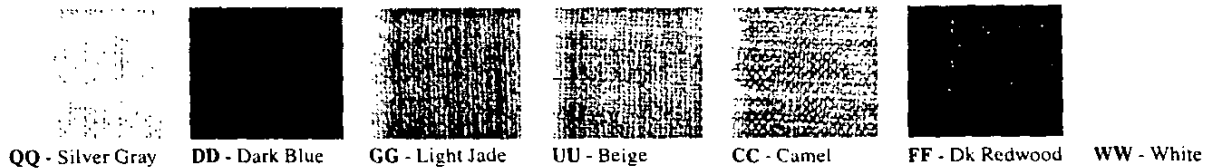

BODY PIN STRIPING AND VINYL ROOF COMBINATIONS

WITHOUT RPO D84 CUSTOM TWO-TONE PAINT

EXTERIOR COLOR	COLOR CODE	INTERIOR TRIM COLOR				
		DARK BLUE	CAMEL	JADE	REDWOOD	SILVER GRAY
White	11 STRIPE VINYL ROOF	R Blue DD or WW	R Gold CC or WW	R Jade GG or WW	R Redwood FF or WW	R Charcoal QQ or WW
Silver (Met)	16 STRIPE VINYL ROOF	R Blue DD	N/R Charcoal QQ	A Charcoal QQ	A Redwood FF	R Charcoal QQ
Light Blue (Met)	21 STRIPE VINYL ROOF	R Blue DD	N/R Blue DD	N/R Blue DD	N/R Blue DD	N/R Blue DD
Dark Blue (Met)	29 STRIPE VINYL ROOF	R Blue DD	R Gold CC or DD	N/R Blue DD	N/R Blue DD	R Silver DD or QQ
Light Jade (Met)	45 STRIPE VINYL ROOF	N/R Jade GG	N/R Jade GG	R Jade GG	N/R Jade GG	N/R Jade GG
Dark Jade (Met)	49 STRIPE VINYL ROOF	N/R Jade GG	R Gold CC	R Jade GG	N/R Jade GG	N/R Silver QQ
Beige	63 STRIPE VINYL ROOF	R Blue DD or UU	R Gold UU	N/R Gold UU	R Redwood UU	N/R Gold UU
Light Brown (Met)	68 STRIPE VINYL ROOF	N/R Beige UU	R Gold CC	N/R Beige UU	N/R Beige UU	N/R Beige UU
Light Redwood (Met)	72 STRIPE VINYL ROOF	N/R Redwood FF	N/R Redwood FF	N/R Redwood FF	R Redwood FF	N/R Redwood FF
Redwood (Met)	77 STRIPE VINYL ROOF	N/R Gold FF	R Gold CC or FF	N/R Gold FF	R Gold FF	N/R Silver QQ
Silver Gray	80 STRIPE VINYL ROOF	R Blue DD or QQ	N/R Charcoal QQ	N/R Charcoal QQ	R Redwood QQ	R Charcoal QQ
Charcoal (Met)	84 STRIPE VINYL ROOF	N/R Silver QQ	N/R Silver QQ	R Silver QQ	N/R Silver QQ	R Silver QQ

R = Recommended Combinations A = Acceptable Combinations
N/R = Non-Recommended Combination (Reqs. D60 Non-Recommended Color Combination Option)

See Dealer Order Guide for latest available information.

Monte Carlo 11

OPTIONAL EQUIPMENT

Air Conditioning. Includes 63-amp generator	RPO C60	AM/FM Stereo Radio with Stereo Cassette Tape ...	RPO UN3
Axle, Limited Slip Differential	G80	Speakers, Dual Rear (available with AM, AM/FM	
Battery, Heavy-Duty (included with V10)	UA1	Monaural Radio only)	U81
Clock, Quartz Electric	U35	Power Antenna	U75
Cold Climate Package (Diesel)	V10	Roof Cover, Vinyl, Padded Landau. (See Color and	
Cooling, Heavy-Duty	VO8	Trim Selections)	--
Defogger, Electric Rear Window	C49	Roof Panels, Removable Glass. With tinted glass	
Door Lock System, Power	AU3	panels	CC1
Floor Covering. Mats, color-keyed floor,		Seat Equipment:	
front and rear	B37	Six-way power front seat. Bench seat or driver's	
Gage Package. Includes temperature,		side only with 55/45 seat	AG9
voltmeter, oil pressure gages, trip odometer and		55/45 front seat (See Color and Trim Selections) ...	--
quartz clock	UF7	Speed Control, Automatic with Resume Speed	K35
Glass, Tinted. All windows	AO1	Steering Wheel, Comfortilt	N33
Headlamps, Halogen Hi-Beam	TT5	Striping, Body Pin	D85
Lamps, Cornering	T87	Suspension Equipment:	
Lighting, Auxiliary. Includes automatic time-delay		Heavy-Duty Front and Rear Suspension. Includes	
dome lamps, luggage compartment lamp,		higher rate springs and revised shock absorber	
underhood lamp, headlamp-on reminder	TR9	valving (NA with diesel)	F40
Luggage Compartment Trim, Deluxe	B48	Sport Suspension requires P205/70R-14 steel-	
Mirrors:		belted radial ply white-stripe tires. Includes larger	
Sport, LH remote & RH manual	D35	diameter front stabilizer bar, added rear stabilizer	
Sport, Twin remote	D68	bar, higher rate springs and revised shock absorber	
Visor, Illuminated RH	D64	valving (NA with diesel)	F41
Moldings:		Tires:	
Body Side, Deluxe, vinyl center insert, with bright		P195/75R-14 steel-belted radial ply white-stripe ...	QVJ
upper and lower edges	BW2	P205/70R-14 steel-belted radial ply white-stripe	
Door Edge Guards	B93	(requires F41 suspension)	QYB
Side Window Sill and hood rear	B85	Puncture-sealant tire (requires QVJ tires)	P42
Paint, Custom Two-Tone (See Color and Trim		Trim, Custom Interior: (See Color and Trim	
Selections)	D84	Selections)	
GM-Delco Radio Equipment:		Trunk Opener, Power	A90
(All radios include dual front speakers and fixed-		Wheel Equipment:	
length fender antenna; all stereos include dual rear		Rally wheels	ZJ7
speakers)		Wire wheel covers	N95
AM Radio	U63	Locking Package, wheel cover (NA N90, ZJ7)	N18
AM/FM Radio	U69	Aluminum wheels	N90
AM/FM Stereo Radio	U58	Windows, Power	A31
AM/FM Stereo Radio with 8-Track Stereo Tape	UM2	Windshield Wiper System, Intermittent	CD4
		<i>NA — Not Available</i>	

BODY FEATURES

SOUND-DEADENING FEATURES

The process of keeping unwanted sounds from the passenger compartment of the 1982 Monte Carlo began with the very first design stages. The necessary fixture holes and joints are kept to a minimum for easy sealing. From that point on, the various insulators, acoustic materials and applications combine to help make Monte Carlo a pleasant car to drive or ride. Some of the specific areas of sound-deadening features are listed below:

- A one-piece, molded acoustic material is bonded directly to cut-pile carpeting and covers the entire floor. It provides a more precise fit than conventional multi-piece carpets. The whole carpet "assembly" itself has a minimum of holes or dirt-catching crevices and provides a highly effective noise barrier.
- The headlining, too, is a one-piece assembly that has a molded backing, covered by a luxurious, thick, foam-backed cloth. It is easier to install and requires less "fitting" to assure a smooth surface.
- Hood insulator pad and dash panel sound barriers are standard.
- Sprayed-on mastics and deadeners on wheelhousings and inner door panels plus acoustic pads and/or Amberlite® in the rear ledge, roof quarter and cowl areas add to the level of quiet.
- The door weatherstripping is augmented by door lower auxiliary seals to help keep the road noises, such as pavement "hiss" in wet weather, out of the passenger compartment.

ANTI-CORROSION MEASURES

As part of a continuing effort the effects of both air and road-borne

corrosive elements have been reduced by basic design considerations. In the initial inception of the 1982 Monte Carlo, many areas that might be susceptible to corrosion are actually "designed out." Even the remaining areas are designed in such a way that they can be assembled with corrosion-resisting steels and materials or easily coated during manufacture. Every critical area is treated, and includes:

- Zinc-rich precoated metal is used in the outer rockers, door panels and outer mirror reinforcement . . . in the spare tire well, along the drip molding area and on the rear wheelhousings.
- Zinc-rich precoated metal is also used in the cowl area . . . on the windshield wiper mounting plate, on the upper shroud and window support, plus the instrument panel-to-fender plate and panel-to-chassis brace.
- Zinc-rich metal in the floor and luggage compartment pans, in the body-mounting areas as well as in the gas tank reinforcement.
- Electroprecoated metal with primer is used on the rear quarter outer panels.
- Zinc primer is applied to the lower door panel, dash panel, door hinge pillar and floor pan extensions.
- Zinc chromate and wax spray on the door upper frame.
- Primer and wax spray covers the quarter panel interior pockets and inner door panels.
- Wax-base spray is applied on front fender inner sides and rear reinforcements.
- Special rust primer and regular primer coats the door open facings, floor pan and door hinges.

- Abrasion-resistant coatings on lower door and quarter outer panels.
- Phosphate oil-impregnated hood hinges.
- Plastisol® film is used to seal trunk lid and door hem flanges.
- Aluminum with precoated metal rear window-to-deck-lid panel support.
- Hot-melt sealer flows into wheel-housing joints during welding.

In addition, precision-molded polymers are used for bumper outer surfaces, front end panel, front fender skirts and heater air conditioning module. Grille, plus tail lamp and headlamp bezels are bright-finished polymers that won't rust.

FINAL FINISHING STEPS

After the initial anti-corrosion and sound-deadening operations, the assembled body is further primed either by the electrodeposition process or by a spray process using a corrosion-resistant flash primer. A primer surfacer is then applied over the primer.

- After baking, the primer surfacer is wet-sanded both with power sanders and hand sanders to help assure a smooth surface for the color topcoat.
- The color topcoat is then applied to a specified film thickness.
- This topcoat is then thoroughly baked.
- After the final baking process, the finish is carefully checked after final assembly and any mars, nicks or scratches that have been detected are corrected at the factory before shipment.

POWER TEAMS

Engine	RPO No.	Power Rating*	Displacement (cubic inches)	Engine Availability	Automatic Transmission RPO MX1	Rear Axle Ratio
--------	---------	---------------	-----------------------------	---------------------	--------------------------------	-----------------

ALL STATES EXCEPT CALIFORNIA
(with Standard Emission System — RPO NA5)

3.8 Liter 2-Bbl. V6 (A)	LC3	110	229	Std.	Std.	2.41
4.4 Liter 2-Bbl. V8 (C)	L39	115	267	EC	Std.	2.29
5.7 Liter Diesel V8 (D)	LF9	105	350	EC	Std.	2.29

CALIFORNIA ONLY
(with California Emission Requirements — RPO YF5)

3.8 Liter 2-Bbl. V6 (B)	LD5	110	231	Std.	Std.	2.41
5.0 Liter 4-Bbl. V8 (C)	LG4	115	305	EC	Std.	2.29
5.7 Liter Diesel V8 (D)	LF9	105	350	EC	Std.	2.29

*S.A.E. net horsepower as installed. Std. — Standard. EC — Optional at extra cost.

- (A) Produced by GM — Chevrolet Motor Division.
 (B) Produced by GM — Buick Motor Division.
 (C) Produced by GM — Chevrolet Motor Division and GM of Canada.
 (D) Produced by GM — Oldsmobile Motor Division.

A Word About Engines

Chevrolets are equipped with GM-built engines produced by various divisions. See your dealer for details.

See EPA section for mileage estimates.

DIMENSIONS/SPECIFICATIONS

EXTERIOR DIMENSIONS	Monte Carlo Sport Coupe
Wheelbase	108.1
Length (overall)	200.4
Width (overall)	71.8
Height (loaded)	54.3
Front tread	58.5
Rear tread	57.8
Minimum ground clearance	5.3
INTERIOR ROOMINESS	
Head room — front	37.6
Head room — rear	37.8
Leg room — front	42.8
Leg room — rear	36.3
Hip room — front	51.7
Hip room — rear	54.9
Shoulder room — front	56.3
Shoulder room — rear	55.9
LUGGAGE COMPARTMENT	
Liftover height	24.3
Usable luggage space (cu. ft.)	16.8
RATED FUEL TANK CAPACITY (gallons)	18.1
CURB WEIGHT (pounds)	3209

1982 MONTE CARLO

ORDERING INFORMATION

MODEL

MONTE CARLO
Sport Coupe.

Model Number
1G237



NEW FEATURES

- Diesel engine now available in all states.
- New finely textured grille.
- Right-hand outside rearview mirror.
- Padded opera-style vinyl roof will be optional.
- Fold-down center armrest in standard interior.
- New 100,000-mile-plus odometer.
- Low-drag front disc brakes.
- Column-mounted dimmer switch now also includes wiper/washer controls.
- Fixed-length fender antenna with all optional radios.
- Dual-nozzle fluidic windshield washer system.
- Engine block and fuel line heater for diesel available.

CONTINUED STANDARD FEATURES

- Automatic transmission.
- Power steering.
- Power disc/drum brake system.
- Delco Freedom II battery.
- High Energy Ignition system.
- Dual horns.
- Flow-through ventilation system.
- Glove compartment lock and light.
- Compact spare tire.
- Inside hood release.

EQUIPMENT SUMMARY

	Sport Coupe
Quad rectangular headlamps	S
Dual chrome outside rearview mirrors	S
Sport mirrors LH remote & RH manual	EC
Bright roof drip moldings	S
Body pin striping	EC
Wheel opening moldings	S
Full wheel covers	S
Hood ornament	S
Padded opera-style vinyl roof cover	EC
Quartz electric clock	EC
Fold-down armrest in front seat	S
Custom 55/45 seats	EC
Glove compartment, courtesy and ashtray lamps	S
Quiet Sound Group	S
3.8 Liter 2-Bbl. V6 (229 CID-Federal; 231 CID-Calif.)	S
P195/75R-14 steel-belted radial ply blackwall tires and 6" wheels	S

S—Standard EC—Extra Cost

Refer to Dealer Order Guide for option availability and application.

1982 MONTE CARLO INTERIORS

Below is a sample of all seat trim materials and seat types to help select the specific interior trim and color on 1982 Monte Carlo models.

MONTE CARLO CUSTOM INTERIOR Cloth trim with bench seat.

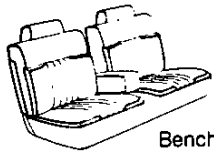

Bench Seat

CLOTH

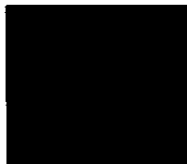

Dark Blue

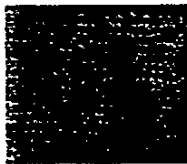

Jade

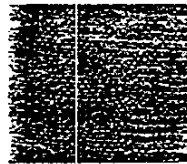

Camel



Redwood

MONTE CARLO INTERIOR Cloth or Vinyl trim with Bench or 55/45 Seat.

CLOTH

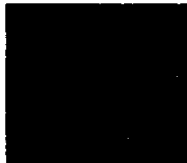

Dark Blue



Camel

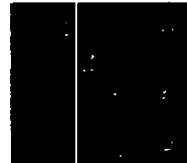

Redwood

VINYL



Silver Gray

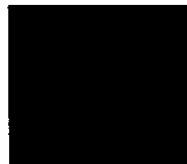

Dark Blue

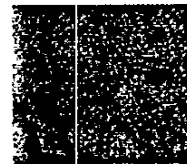

Camel



Redwood

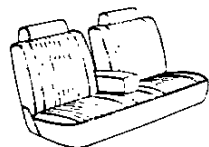

Bench Seat

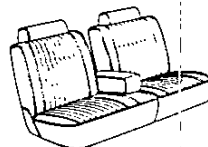

Available 55/45 Seat

Refer to Dealer Order Guide for option availability and application.

Exterior Colors

11 - White



63 - Beige

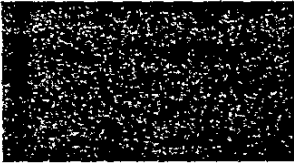

16 - Silver (Metallic)

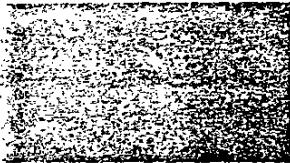

68 - Light Brown (Metallic)

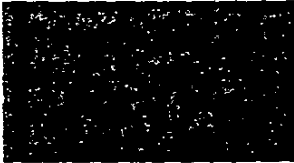

21 - Light Blue (Metallic)



72 - Light Redwood (Metallic)



29 - Dark Blue (Metallic)

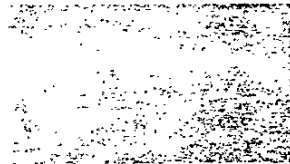

77 - Redwood (Metallic)



45 - Light Jade (Metallic)



80 - Silver Gray

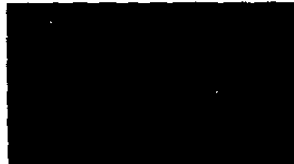

49 - Dark Jade (Metallic)



84 - Charcoal (Metallic)

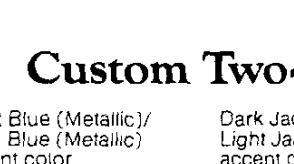

Vinyl Roof Cover

Padded opera-style vinyl roof. Available in seven colors.

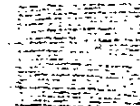
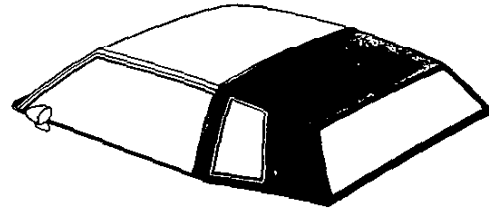

Silver Gray



Dark Blue

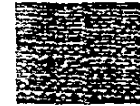

Light Jade



Beige

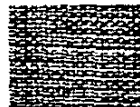

Camel



Dark Redwood



White

Custom Two-Tone Paint (RPO D84)

White/Silver Gray
accent color

Light Blue (Metallic)/
Dark Blue (Metallic)
accent color

Dark Jade (Metallic)/
Light Jade (Metallic)
accent color

Beige/Dark Blue
(Metallic) accent color

Beige/Redwood
(Metallic) accent color

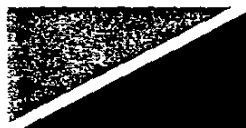

Light Redwood (Metallic)/
Redwood (Metallic)
accent color

NOTE: Accent color on hood, roof and around side windows.

Refer to Dealer Order Guide for option availability and application.



ALPHABETICAL OPTION INDEX

(Not for ordering purposes)

Option Number	Description	Option Number	Description
AG9	SEAT, POWER: Six-Way	NA5	EMISSION SYSTEM: Standard Emission Equipment
AU3	DOOR LOCK SYSTEM, POWER	NA6	EMISSION SYSTEM: High Altitude Emission Equipment
A01	GLASS, TINTED: All Windows	N18	WHEEL COVER LOCKING PACKAGE
A31	WINDOWS, POWER	N33	STEERING WHEEL: Comfortilt
A90	TRUNK OPENER, POWER	N90	WHEEL TRIM: Wheels, Aluminum
BW2	MOLDINGS: Body Side, Deluxe	N95	WHEEL TRIM: Wheel Covers, Wire
B3W	PRELIMINARY PRICE INFORMATION	P42	PUNCTURE SEALANT TIRES
B37	FLOOR COVERING: Mats, Color-Keyed Floor. Front and Rear	QVJ	TIRES: P195/75 R-14 White Stripe (Radial)
B48	LUGGAGE COMPARTMENT TRIM, DELUXE	QVU	TIRES: P205/70 R-14 White Stripe (Radial)
B85	MOLDINGS: Side Window Sill	QXV	TIRES: P195/75 R-14 Blackwall (Radial)
B93	MOLDINGS: Door Edge Guard	QXW	TIRES: P195/75 R-14 White Stripe (Radial)
CC1	ROOF PANELS: Removable Glass	TR9	LIGHTING, AUXILIARY
CD4	WINDSHIELD WIPER SYSTEM: Intermittent	TT5	HEADLAMPS, HALOGEN HI-BEAM
C49	DEFOGGER, REAR WINDOW: Electric	T87	LAMPS, CORNERING
C60	AIR CONDITIONING	UA1	BATTERY, HEAVY-DUTY
D35	MIRRORS: Sport, LH Remote and RH Manual	UF7	GAGE PACKAGE WITH TRIP ODOMETER
D60	NON-RECOMMENDED COLOR COMBINATION	UM2	RADIO EQUIPMENT: AM/FM Stereo Radio with 8-Track Stereo Tape
D64	MIRROR: RH Visor, Illuminated	UN3	RADIO EQUIPMENT: AM/FM Stereo Radio with Stereo Cassette Tape
D68	MIRRORS: Sport, Twin Remote	U35	CLOCK: Quartz Electric
D84	PAINT: Custom Two-Tone	U58	RADIO EQUIPMENT: AM/FM Stereo Radio
D85	STRIPING, PIN: Body	U63	RADIO EQUIPMENT: AM Radio
F40	SUSPENSION EQUIPMENT: Suspension, Heavy-Duty Front and Rear	U69	RADIO EQUIPMENT: AM/FM Radio
F41	SUSPENSION EQUIPMENT: Suspension, Sport	U73	RADIO EQUIPMENT: Fixed Mast Antenna
G80	AXLE, REAR: Limited Slip Differential	U75	RADIO EQUIPMENT: Power Antenna
✓ G84	AXLE, REAR: High Altitude Ratio	U81	RADIO EQUIPMENT: Speakers, Dual
K35	SPEED CONTROL, AUTOMATIC: With Resume Speed	V08	COOLING, HEAVY-DUTY
LC3	ENGINE: 3.8 Liter 2 BBL V6	V10	COLD CLIMATE PACKAGE
LD5	ENGINE: 3.8 Liter 2 BBL V6	YF5	EMISSION SYSTEM: California Emission Requirements
LF9	ENGINE: 5.7 Liter Diesel V8 With Water-In-Fuel Indicator	ZJ7	WHEEL TRIM: Wheels, Rally
LG4	ENGINE: 5.0 Liter 4 BBL V8	29M	ACCENT COLOR: Dk Blue Metallic
LT6	ENGINE: 4.3 Liter Diesel V6 With Water-In-Fuel Indicator	45M	ACCENT COLOR: Lt Jade Metallic
L39	ENGINE: 4.4 Liter 2 BBL V8	77M	ACCENT COLOR: Redwood Metallic
		80M	ACCENT COLOR: Silver Gray



MONTE CARLO

REFER WEEKLY STOPS/LATEST UPDATE

MODEL

1GZ37 Monte Carlo Sport Coupe

ENGINES: MUST ORDER ONE (See Power Teams)

STANDARD EMISSION EQUIPMENT (Does Not Satisfy High Altitude Requirements)—REQUIRES NA5

- _____ LT6 4.3 Liter Diesel V8 With Water-In-Fuel Indicator (V10 Cold Climate Package Recommended for use in Cold Climate Areas)
- _____ LF9 5.7 Liter Diesel V8 with Water-In-Fuel Indicator (V10 Cold Climate Package Recommended for use in Cold Climate Areas)

STANDARD EMISSION EQUIPMENT (Also Satisfies High Altitude Requirements)—REQUIRES NA5

- _____ LC3 3.8 Liter 2 BBL V8
- _____ L39 4.4 Liter 2 BBL V8

HIGH ALTITUDE EMISSION EQUIPMENT—REQUIRES NA6

- ✓ _____ LC3 3.8 Liter 2 BBL V8 (Reqs G84 Axle) (FOR PERFORMANCE PURPOSES; NOT REQUIRED TO SATISFY HIGH ALTITUDE EMISSION REGULATIONS)
- _____ LT6 4.3 Liter Diesel V8 with Water-In-Fuel Indicator (Reqs V10 Cold Climate Package)
- ✓ _____ L39 4.4 Liter 2 BBL V8 (Reqs G84 Axle) (FOR PERFORMANCE PURPOSES; NOT REQUIRED TO SATISFY HIGH ALTITUDE EMISSION REGULATIONS)
- _____ LF9 5.7 Liter Diesel V8 with Water-In-Fuel Indicator (Reqs C60 Air and V10 Cold Climate Package)

CALIFORNIA EMISSION EQUIPMENT—REQUIRES YF5

- _____ LD5 3.8 Liter 2 BBL V8
- _____ LG4 5.0 Liter 4 BBL V8
- _____ LF9 5.7 Liter Diesel V8 with Water-In-Fuel Indicator (V10 Cold Climate Package Recommended for use in Cold Climate Areas)

EMISSION SYSTEMS: MUST ORDER ONE (See Above)

- _____ NA5 Standard Emission Equipment
- _____ NA6 High Altitude Emission Equipment
- _____ YF5 California Emission Requirements

QUICK-SPEC

IF TIRE IN QUICK-SPEC IS NOT DESIRED YOU MUST 'PLUS' ANOTHER TIRE OPTION.

3	3	3	3	3
2	2	2	2	3
6	7	8	9	0
A	A	A	A	A

Air Conditioning	C60	x	x	x	x	x
Clock, Quartz Electric	U35	x	x	x	x	x
Glass, Tinted	A01	x	x	x	x	x
Moldings, Body Side Deluxe	BW2	x	x	x	x	x
Radio, AM	U63	x	x	N/I	N/I	N/I
Tires, P195/75 R-14 White Stripe	QVJ	x	x	x	x	x

Lighting, Auxiliary	TR9	x	x	x	x	x
Mats, Color-Keyed Floor	B37	x	x	x	x	x
Moldings, Door Edge Guard	B93	x	x	x	x	x
Moldings, Side Window Sill	B85	x	x	x	x	x
Speed Control with Resume Speed	K35	x	x	x	x	x
Steering Wheel, Comfortilt	N33	x	x	x	x	x
Wheels, Rally	ZJ7	x	x	N/I	N/I	

Defogger, Rear Window Electric	C49	x	x	x		
Door Lock System, Power	AU3	x	x	x		
Mirrors Sport, LH Remote, RH Manual	D35	x	x	x		
Radio, AM/FM	U69	x	N/I	N/I		
Windows, Power	A31	x	x	x		

Gage Pkg w/Trip Odometer (w/o LT6 or LF9 Eng)	UF7			x	x	
Radio, AM/FM Stereo	U58			x	N/I	
Wheel Cover Locking Package	N18			x	x	
Wheel Covers, Wire	N95			x	x	
W/S Wiper System, Intermittent	CD4			x	x	

Antenna, Power	U75			x		
Radio, AM/FM Stereo w/8-Track Stereo Tape	UM2			x		
Seat, Power	AG9			x		
Trunk Opener, Power	A80			x		

PLEASE REVIEW OPTION RESTRICTIONS BEFORE ORDERING

QS	OPTION		
326	C60	AIR CONDITIONING	
✓	G84	AXLES, REAR: —High Altitude Ratio (Reqs NA6 Emissions and LC3 or L39 Eng)	
_____	G80	—Limited Slip Differential	
_____	UA1	BATTERY, HEAVY-DUTY	
326	U35	CLOCK: Quartz Electric (Incl w/UF7 Gage Package)	
_____	V10	COLD CLIMATE PACKAGE: (Reqs LT6 or LF9 Eng) (Incls UA1 Battery) (Recommended for use in Cold Climate Areas)	
✓	V08	COOLING, HEAVY-DUTY: (w/LT6 or LF9 Eng N/A C60 Air)	
328	C49	DEFOGGER, REAR WINDOW: Electric	
328	AU3	DOOR LOCK SYSTEM, POWER	
327	B37	FLOOR COVERING: Mats, Color-Keyed Floor. Front and Rear	
329	UF7	GAGE PACKAGE WITH TRIP ODOMETER: (N/A LT6 or LF9 Engine)	
326	A01	GLASS, TINTED: All Windows	
_____	TT5	HEADLAMPS, HALOGEN HI-BEAM	
_____	T87	LAMPS, CORNERING	
327	TR9	LIGHTING, AUXILIARY	
_____	B48	LUGGAGE COMPARTMENT TRIM, DELUXE	
_____		MIRRORS:	
328	D35	—Sport, LH Remote and RH Manual	
_____	D68	—Sport, Twin Remote	
_____	D64	—RH Visor, Illuminated	
326	BW2	MOLDINGS: —Body Side, Deluxe (See Page 4 for Color Application of the two Available Color Moldings)	
327	B93	—Door Edge Guard	
327	B85	—Side Window Sill	
_____	D84	PAINT, CUSTOM TWO-TONE: (Refer Page 2 for Exterior Paint Availability and Page 4 for Add'l Information)	
_____	B3W	PRELIMINARY PRICE INFORMATION	
326	U63	RADIO EQUIPMENT: —AM Radio	
328	U69	—AM/FM Radio	
329	U58	—AM/FM Stereo Radio	
330	UM2	—AM/FM Stereo Radio w/8-Track Stereo Tape	
_____	UN3	—AM/FM Stereo Radio w/Stereo Cassette Tape	
_____	U81	—Speakers, Dual Rear (Reqs U63 or U69 Radio) (Incl w/U58, UM2 or UN3 Radio)	
_____	U73	—Fixed Mast Antenna (Incl w/U63, U69, U58, UM2 or UN3 Radio)	
330	U75	—Power Antenna (Reqs U63, U69, U58, UM2 or UN3 Radio) (N/A U73 Antenna)	
_____		ROOF COVER, LANDAU VINYL: (See Vinyl Roof Selector)	
_____	CC1	ROOF PANELS: Removable Glass	
✓	330	AG9	SEAT, POWER: Six-Way (Reqs Custom Trim or 55/45 Seat) (Driver's Side only w/55/45 Seat)
327	K35	SPEED CONTROL, AUTOMATIC: With Resume Speed	
327	N33	STEERING WHEEL: Comfortilt	
_____	D85	STRIPING, PIN: Body (N/A D84 Paint) (Refer to Page 4 for Stripe Color Application)	
_____		SUSPENSION EQUIPMENT:	
_____	F40	—Heavy-Duty Front and Rear (N/A F41 Susp)	
_____	F41	—Sport (Reqs QVU Tires) (N/A LT6 or LF9 Eng)	
_____		TIRES: (B/W: Blackwall, W/S: White Stripe)	
_____		Steel Belted Radial Ply	
326	QXV	—P195/75 R-14 B/W (Base)	
_____	QVJ	—P195/75 R-14 W/S	
_____	QXW	—P195/75 R-14 W/S (Reqs P42 Tires)	
_____	QVU	—P205/70 R-14 W/S (Reqs F41 Susp)	
_____	P42	—Puncture Sealant Tires (Reqs QXW Tires)	
330	A90	TRUNK OPENER, POWER	
329	N18	WHEEL COVER LOCKING PACKAGE: (Reqs N95 Wheel Covers)	
_____		WHEEL TRIM:	
_____	N90	—Wheels, Aluminum	
329	N95	—Wheel Covers, Wire	
327	ZJ7	—Wheels, Rally	
328	A31	WINDOWS, POWER	
329	CD4	WINDSHIELD WIPER SYSTEM: Intermittent	



MONTE CARLO

1982 VEHICLES WITH STANDARD EQUIPMENT

Prices shown are effective with vehicles produced on or after June 14, 1982

Description	Model Number	Body Code	Wheel Base	Dealer Invoice Amount*	Dealer Price	Factory D&H(a)	List Price	Mfr's Sg'd Retail Price*	Group Number
◆ 6-Cylinder Engine Sport Coupe.....	1GZ37	—	108.1*					8177.10	3

- ★ Manufacturer's Suggested Retail Prices do not include applicable destination charges, state and local taxes, license fees, optional equipment or accessories or special items or services.
- ◆ Refer to Dealer Order Guide for California Requirements.

OPTIONS AND ACCESSORIES WHEN INSTALLED BY CHEVROLET

Prices shown are effective with vehicles produced on or after June 14, 1982

Description	Option Number	Dealer Invoice Amount*	Dealer Price	Factory D&H(a)	List Price	Mfr's Suggested Retail Price◇
-------------	---------------	------------------------	--------------	----------------	------------	-------------------------------

REFER TO DEALER ORDER GUIDE FOR OPTION AVAILABILITY AND APPLICATION

Interior Trim:						
C**1 Cloth Bench Seat.....					NO ADDITIONAL CHARGE	
C**3 Cloth 55 /45.....						133.00
V**1 Vinyl Bench Seat.....						28.00
V**3 Vinyl 55 /45.....						181.00
F**1 Custom Cloth Bench Seat.....						358.00
Exterior Color:						
Paint, Solid.....					NO ADDITIONAL CHARGE	
Custom Two-Tone. Includes upper body accent, color-keyed striping.....	D84					214.00
Roof Cover, Vinyl Landau.....						232.00
Engines: (Refer to Dealer Order Guide for Emission System Requirements)						
3.8 Liter 2 BBL V6.....	LC3				NO ADDITIONAL CHARGE	
3.8 Liter 2 BBL V6.....	LD5				NO ADDITIONAL CHARGE	
4.4 Liter 2 BBL V8.....	L39					120.00
5.0 Liter 4 BBL V8.....	LG4					120.00
4.3 Liter Diesel V6.....	LT8					775.00
5.7 Liter Diesel V8.....	LF9					825.00
Air Conditioning: Includes increased cooling.....	C60					695.00
Axle, Rear:						
Limited Slip Differential.....	G80					85.00
High Altitude Ratio.....	G84				NO ADDITIONAL CHARGE	
Battery, Heavy-Duty. Included with V10 Cold-Climate Package						
Without Diesel Engine.....	UA1					25.00
With Diesel Engine.....	UA1					50.00
Clock: Quartz Electric. Included with UF7 Gage Package.....	U35					32.00
Cooling, Heavy-Duty:						
Without C60 Air Conditioning.....	V08					70.00
With C60 Air Conditioning.....	V08					40.00
Cold-Climate Package Includes UA1 H.D. Battery and engine block and fuel line heater.....						
	V10					99.00
Defogger, Rear Window: Electric	C49					132.00
Door Lock System, Power: Electric	AU3					112.00
Emission Systems:						
<i>California Emission Requirements.</i> Includes all testing, equipment and /or certification necessary for registration in the State of California						
Without Diesel Engine.....	YF5					65.00
With Diesel Engine.....	YF5					205.00
<i>Standard Emission Equipment.</i>						
High Altitude Emission Equipment.....	NA5				NO ADDITIONAL CHARGE	
	NA6				NO ADDITIONAL CHARGE	
Floor Covering: 2 front and 2 rear color-keyed floor mats.....	B37					27.00
Gage Package With Trip Odometer: Includes clock, temperature, voltmeter and oil pressure gages.....	UF7					95.00

* Dealer Invoice Amount includes 3% Holdback Amount retained for dealer's account.

(a) D & H Charges on vehicle and optional equipment include reimbursement to Chevrolet Motor Division for any tax that it has paid, incurred or agreed to pay thereon.

◇ State and local taxes not included.



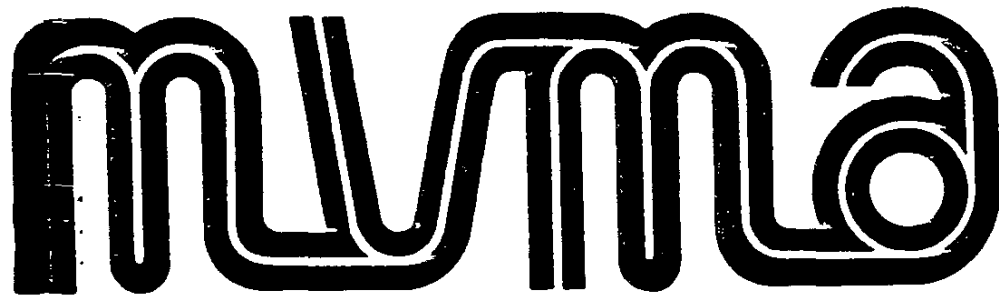

Specifications

Form

Passenger Car

1982

METRIC (U.S. Customary)

Manufacturer CHEVROLET MOTOR DIVISION GENERAL MOTORS CORPORATION	Car Line MONTE CARLO - MALIBU CLASSIC - EL CAMINO	
Mailing Address CHEVROLET ENGINEERING CENTER 30003 VAN DYKE WARREN, MICHIGAN 48090	Model Year 1982	Issued: AUGUST, 1981
		Revised (*): OCTOBER, 1981

NOTE: Sheets revised - 1, 2, 3b, 3, 8a, 8b, 9b, 12, 12a, 13, 13a, 14, 14a, 25, 26, 27, 28, 29
The information contained herein is prepared, distributed by, and is solely the responsibility of the automobile manufacturing company to whose products it relates. Questions concerning these specifications should be directed to the manufacturer whose address is shown above. This specification form was developed by automobile manufacturing companies under the auspices of the Motor Vehicle Manufacturers Association of the United States, Inc.

The General Specifications herein are those in effect at date of completion and are subject to change without notice by the manufacturer.

MVMA Specifications Form

Passenger Car

METRIC (U.S. Customary)

Table of Contents

1	Car Models
2	Power Teams
3-7	Engine
7	Exhaust System
8	Fuel System/Diesel Information
9	Cooling System
10, 11	Vehicle Emission Control
12, 13	Electrical
14-17	Drive Units
17	Tires and Wheels
18	Brakes
19	Steering
20	Suspension — Front and Rear
21	Body — Miscellaneous Information
21	Frame
22	Convenience Equipment
23	Vehicle Mass (Weight)
24	Optional Equipment Mass (Weight)
25-27	Car and Body Dimensions
28	Vehicle Fiducial Marks
29	Glass/Lamps and Headlamp
30-34	Car and Body Dimension Key Sheets
35	Index

NOTE:

- 1 This form uses both SI metric units and U.S. Customary units. The metric unit of measure is presented first, and the U.S. Customary unit follows in parentheses.
2. UNLESS OTHERWISE INDICATED.
 - a. Specifications apply to standard models without optional equipment. Significant deviations are noted.
 - b. Nominal design dimensions are used throughout these specifications.
 - c. All linear dimensions are in millimeters (inches), and all mass (weight) specifications are in kilograms (pounds).
- 3 The General Specifications herein are those in effect at date of completion and are subject to change without notice by the manufacturer.
- 4 A printed or computer tape supplement containing additional Car and Body Dimensions and/or drawings (based in part on SAE J1100a "Motor Vehicle Dimensions") may be available from the manufacturer.

MVMA Specifications Form
Passenger Car
METRIC (U.S. Customary)

Car Line MONTE CARLO-MALIBU CLASSIC-EL CAMINO
 Model Year 1982 Issued 8-81 Revised (*) _____

Engine Description/Carb.
 Engine Code

3.8 LITER V6 (229 CID)
 2-BBL CARBURETOR
 RPO LC3

3.8 LITER V6 (231 CID)
 2-BBL CARBURETOR
 RPO LD5

ENGINE - GENERAL

Type (inline V and angle (lat))	90° V	
Location (front/mid/rear)	FRONT	
Engine installation position (transverse/longitudinal)	Longitudinal	
Number of mtg points	Front	1-0-0
	Rear	0-0-0
No. of cylinders	6	
Bore	95 (3.736)	96.5 (3.80)
Stroke	88.4 (3.48)	86.4 (3.40)
Piston displacement cm ³ (in ³)	3753 (229)	3785 (231)
Bore spacing (cyl to cyl)	111.8 (4.40)	107.7 (4.24)
Cylinder block material	Cast alloy iron	
Cylinder block deck height	229.2 (9.025)	242.8 (9.56)
Deck clearance (minimum) (above/below block)	.025 below	1.91 below
Cylinder head material	Cast alloy iron	
Cylinder head volume - cm ³	58.9 (3.59)	48.19
Head gasket thickness (compressed)	.533 (.021)	.533
Head gasket volume - cm ³	3.98 (.243)	3.93
Minimum combustion chamber volume - cm ³	56.7	87.65
Cyl no system (front to rear)**	L Bank	1-3-5
	R Bank	2-4-6
Firing order	1-6-5-3-2	
Recommended fuel (leaded/unleaded)	Unleaded	
Fuel antiknock index (R - MI)	87	
Total dressed engine mass (w/ drv)	205.0 (453.2)	1207.0 (457.0)

*Dressed engine mass (weight) includes the following All those items necessary to make the engine a complete ready-to-run unit.

**Rear of engine - drive takeoff
 View from drive takeoff end to determine left & right side of engine

MVMA Specifications Form
Passenger Car
METRIC (U.S. Customary)

Car Line MONTE CARLO-MALIBU CLASSIC-EL CAMINO
 Model Year 1982 Issued 8-81 Revised (*) _____

Engine Description/Carb.
 Engine Code

4.4 LITER V8 (267 CID) 2-BBL CARBURETOR RPO L39	5.0 LITER V8 (305 CID) 4-BBL CARBURETOR RPO L64
---	---

ENGINE - GENERAL

Type (inline V and angle flat)	90° 'V'	
Location (front mid rear)	Front	
Engine installation position (transverse longitudinal)	Longitudinal	
Number of mtg points	Front	Two
	Rear	One
No. of cylinders	8	
Bore	88.9 (3.50)	95.0 (3.736)
Stroke	88.4 (3.48)	
Piston displacement cm ³ (in ³)	4375 (267)	4998 (305)
Bore spacing (c/c to c/c)	111.8 (4.40)	
Cylinder block material	Cast alloy iron	
Cylinder block deck height	229.2 (9.025)	229.4 (9.03)
Deck clearance (minimum) (above or below block)	.025 below	
Cylinder head material	Cast alloy iron	
Cylinder head volume - cm ³	51.8 (3.16)	58.9
Head gasket thickness (compressed)	.021	
Head gasket volume - cm ³	3.61	3.98
Minimum combustion chamber volume - cm ³	49.6	56.7
Cyl. no. system (front to rear)**	L Bank	1-3-5-7
	R Bank	2-4-6-8
Firing order	1-8-4-3-6-5-7-2	
Recommended fuel (leaded unleaded)	Unleaded	
Fuel antiknock index (R + M) 2	87	
Total dressed engine mass (w/ drv*)	253.5 (559)	274.3 (605)

*Dressed engine mass (weight) includes the following: All those items necessary to make the engine a complete ready-to-run unit.

**Rear of engine - drive takeoff
 View from drive takeoff end to determine left & right side of engine

MVMA Specifications Form
Passenger Car
METRIC (U.S. Customary)

Car Line MONTE CARLO-MALIBU CLASSIC-EL CAMINO
 Model Year 1982 Issued 8-81 Revised (*) 10-81

Car Models

Model Description (Include Line Drawings of Vehicles if Desired)	Make, Car Line, Series, Body Type (Mfr's Model Code)	No. of Designated Seating Positions (Front/Rear)		Max. Trunk/Cargo Load— Kilograms (Pounds)
	MODEL NUMBER	FRONT	REAR	
Monte Carlo 2-Door Coupe	1GZ37	3	3	73.1 (161.2)
Malibu Classic				
4-Door Sedan	1GW69	3	3	75.2 (165.8)
4-Door Station Wagon	1GW35	3	3	90.7 (200.0)
El Camino				
2-Door Sedan Pickup	1GW80	3	-	362.9 (800.0)

Note: Any specifications on the following pages that are specific to California requirements are indicated accordingly.

MVMA Specifications Form
Passenger Car
METRIC (U.S. Customary)

Car Line MONTE CARLO-MALIBU CLASSIC-EL CAMINO
 Model Year 1982 Issued 8-81 Revised (*) 10-81

Power Teams (Indicate whether standard or optional)

SAE Net bhp (brake horsepower) and net torque corrected to 85° F and 29.38 in Hg atmospheric pressure

SERIES AVAILABILITY	ENGINE						TRANSMISSION	AXLE RATIO	
	Displ Liters (in ³)	Carb (Barrels)	Compr Ratio	SAE Net at RPM		Exhaust System*		Base	Opt.
				kW (bhp)	Torque N - m (lb ft)				
base-All exc. Calif. Sedan & Monte Carlo wagon	V6 3.8 (229) LC3	2	8.6:1	110@ 4200	170@ 2000	S	Auto '250C'-Base (Auto '350C'-Base)@	2.41:1	--
El Camino							Auto '250C'-Base	2.73:1	--
base-Calif. only Sedan & Monte Carlo wagon & El Camino	V6 3.8 (231) LD5	2	8.0:1	110@ 3800	190@ 1600	S	Auto '350C'-Base (Auto '250C'-Base@)	2.41:1	--
Auto '350C'-Base								2.73:1	--
Avail All Sedan & Monte Carlo	V6 4.3 (262) Diesel LT6	Fuel Injec -tion	22.5:1	85@ 3600	165@ 1600	S	Auto '200C'-Base	2.41:1	--
Avail All exc. Calif. Sedan & Monte Carlo wagon & El Camino	V8 4.4 (267) L39	2	8.3:1	115@ 4000	205@ 2400	S	Auto '250C'-Base (Auto '350C'-Base@)	2.29:1	--
Auto '250C'-Base (Auto '350C'-Base@)								2.50:1	--
Avail All wagons & El Camino	V8 5.0 (305) LG4	4	8.0:1	145@ 4000	240@ 1600	S	Auto '250C'-Base (Auto '350C'-Base@)	2.4:1	--
Auto '350C'-Base								--	2.75:1
Avail Calif. only Monte Carlo							Auto '350C'-Base (Auto '250C'-Base@)	2.29:1	--
Avail All exc Calif. Sed. & Monte Carlo+	V8 5.7 (350) Diesel LF9	Fuel Injec -tion	22.5:1	105@ 3200	200@ 1600	S	Auto '350C'-Base	2.29:1	--
Avail Calif. only Sed. & Monte Carlo* wagon							Auto '350C'-Base	2.29:1	--

@ - Manufacturing option.

* - Air conditioning required.

+ - The 5.7 Liter - V8 Diesel will be made available, if availability of the 4.3 Liter - V6 Diesel proves insufficient.

*S-Single D-Dual

MVMA Specifications Form
Passenger Car
METRIC (U.S. Customary)

Car Line MONTE CARLO-MALIBU CLASSIC-EL CAMINO
 Model Year 1982 Issued 8-81 Revised (*) 10-81

Engine Description/Carb.
 Engine Code

4.3 LITER V6 (262 CID)
 FUEL INJECTION DIESEL
 RPO L75

ENGINE -- GENERAL

Type (inline V and angle flat)	90° 'V'	
Location (front mid rear)	Front	
Engine installation position (transverse, longitudinal)	Longitudinal	
Number of mtg. points	Front	2
	Rear	1
No. of cylinders	6	
Bore	103.05 (4.057)	
Stroke	85.98 (3.385)	
Piston displacement cm ³ (in ³)	4.3 (262.5)	
Bore spacing (cyl to cyl)	117.5 (4.625)	
Cylinder block material	Cast iron	
Cylinder block deck height	237 (9.330 + .005)	
Deck clearance (minimum) above or below block	.46 (.018 above)	
Cylinder head material	Cast iron	
Cylinder head volume - cm ³	21.48 (1.311 in ³)	
Head gasket thickness (compressed)	1.17-1.22 (.046-.048)	
Head gasket volume - cm ³	10.17 (.6205 in ³)	
Minimum combustion chamber volume - cm ³	33.41 (2.039 in ³)	
Cyl. no. system (front to rear)**	L Bank	1-3-5
	R Bank	2-4-6
Firing order	1-6-5-4-3-2	
Recommended fuel leaded unleaded	Diesel fuel #2 (above 20°F) #1 (below 20°F)	
Fuel antiknock index R + M 2		
Total dressed engine mass (w/ oil dry*)	261.0 (575.4)	

*Dressed engine mass (weight) includes the following: All those items necessary to make the engine a complete ready-to-run unit.

**Rear of engine - drive takeoff

View from drive takeoff end to determine left & right side of engine

MVMA Specifications Form
Passenger Car
METRIC (U.S. Customary)

Car Line MONTE CARLO-MALIBU CLASSIC-FL CAMINO
 Model Year 1982 issued 8-81 Revised (*)

Engine Description/Carb.
 Engine Code

5.7 LITER V8 (350 CID)
 FUEL INJECTION DIESEL
 RPU 1 F9

ENGINE - GENERAL

Type (inline V and angle flat)	90° 'V'	
Location (front mid.rear)	Front	
Engine installation position (transverse longitudinal)	Longitudinal	
Number of mtg points	Front	2
	Rear	1
No. of cylinders	8	
Bore	103.05 (4.057)	
Stroke	85.98 (3.385)	
Piston displacement cm ³ (in ³)	5.7 (350)	
Bore spacing (c to c)	117.5 (4.625)	
Cylinder block material	Cast iron	
Cylinder block deck height	237 (9.330 +/- .005)	
Deck clearance (minimum) (above or below block)	.46 (.018 above)	
Cylinder head material	Cast iron	
Cylinder head volume - cm ³	21.48 (1.311 in ³)	
Head gasket thickness (compressed)	1.17-1.22 (.046-.048)	
Head gasket volume - cm ³	10.17 (.6205 in ³)	
Minimum combustion chamber volume - cm ³	33.41 (2.039 in ³)	
Cyl. no. system (front to rear)**	L. Bank	1-3-5-7
	R. Bank	2-4-6-8
Firing order	1-8-4-3-6-5-7-2	
Recommended fuel (leaded unleaded)	Diesel fuel #2 (above 20°F) #1 (below 20°F)	
Fuel antiknock index $\frac{R+M}{2}$		
Total dressed engine mass (w/ drv)	# 315.3 (695.1)	328.9 (725.1)

*Dressed engine mass (w/ drv) includes to following All those items necessary to make the engine a complete ready-to-run unit.
 # Alum. Intake

**Rear of engine - drive takeoff
 View from drive takeoff end to determine left & right side of engine

Passenger Car
METRIC (U.S. Customary)

Model Year 1982 Issued 8-81 Revised (*)

Engine Description/Carb
Engine Code

3.8 LITER V6 (229 CID) 2-BBL CARBURETOR RPO 1C3	3.8 LITER V6 (231 CID) 2-BBL CARBURETOR RPO 1D5
---	---

Engine - Pistons

Material		Cast aluminum alloy	
Description and finish (flat, dished, dome, etc.)		Closed skirt, sumped head	Full skirt with transverse slot, dished head
Mass (weight oz) - Piston Only		502 (17.71)	454 (16.01)
Clearance (limits)	Top land	.022-.051 (.0045-.0335)	1.19-1.32 (.047-.052)
	Skirt	Top	.018-.047 (.0007-.0042)
		Bottom	.04-.10 (.0016-.0038)
Ring groove diameter	No 1 ring	84.33-84.71 (3.320-3.335)	86.10-85.73 (3.390-3.375)
	No 2 ring	84.33-84.71 (3.320-3.335)	86.10-85.73 (3.390-3.375)
	No 3 ring	83.82-84.20 (3.300-3.315)	86.26-85.93 (

Engine - Piston Rings

Function (top to bottom)	No 1 oil or comp	Compression	
	No 2 oil or comp	Compression	
	No 3 oil or comp	Oil	
Compression	Description - material coating etc	Upper - Molybdenum filled channel, barrel face Lower - Inside bevel, reverse tapered face	
	Width	1.96-1.98 (.0770-.0780)	
	Gap	0.25-0.51 (.010-.020)	
Oil	Description - material coating etc	TRW "T" flex design .002" min. chrome	Multi-piece, (2) rails & (1) expander stainless steel - 50
	Width	4.52-4.62 (.178-.182)	.597-.622 (.0235-.0245)
	Gap	0.25-0.69 (.010-.035)	.038-1.40 (.015-.055)
Expanders	In oil ring assembly		Abutment type

Engine - Piston Pins

Material		AISI 5015	
Length		75.95-76.45 (2.990-3.010)	73.60 (2.90)
Diameter		23.546-23.553 (.9270-.9273)	23.653-23.800 (.9391-.9394)
Type	Locked in rod, in piston, floating, etc	Locked in rod	Pressed in rod
	Bushing	In rod or piston	Material
Clearance	In piston	.0013-.0075 (.00005-.00030)	.008-.023 (.0003-.0009)
	In rod		.018-.043 (.0007-.0017)
Direction & amount offset in piston		Major thrust side-.152 (.060)	Major thrust side-.102 (.040)

MVMA Specifications Form
Passenger Car
METRIC (U.S. Customary)

Car Line MONTE CARLO-MALIBU CLASSIC-EL CAMILO
 Model Year 1982 Issued 8-81 Revised (*)

Engine Description/Carb Engine Code	4.4 LITER V8 (267 CID) 2-BBL CARBURETOR RPO 139	5.0 LITER V8 (350 CID) 4-BBL CARBURETOR RPO 164
--	---	---

Engine - Pistons

Material	Cast aluminum alloy	
Description and finish (flat, dished, dome, etc.)	Closed skirt, sumphead	
Mass g (weight oz) - Piston Only	445 (15.69)	502 (17.7)
Clearance (limits)	Top land	.635-.787 (.025-.031)
	Skirt	Top
		Bottom
Ring groove diameter	No 1 ring	79.04-79.30 (3.112-3.122)
	No 2 ring	79.04-79.30 (3.112-3.122)
	No 3 ring	77.98-78.23 (3.070-3.080)

Engine - Piston Rings

Function (top to bottom)	No 1 oil or comp	COMPRESSION
	No 2 oil or comp	COMPRESSION
	No 3 oil or comp	OIL
Compression	Description - material coating etc	Upper - cast alloy iron, radius-face, chrome flash Lower - cast alloy iron, reverse twist, tapered face lubricated
	Width	1.96-1.98 (.0773-.0780)
	Gap upper	0.25-.051 (.010-.020)
Oil	Description - material coating, etc	TRW 'T' flex design .05 mm (.022" min. chrome)
	Width	4.71 (.1855)
	Gap	0.25-0.762 (.010-.030)
Expanders	In oil ring assembly	

Engine - Piston Pins

Material	AISI 5015	AISI 5015
Length	69.60-70.10 (2.740-2.760)	75.95-76.45 (2.990-3.010)
Diameter	23.546-23.553 (.9270-.9273)	
Type	Locked in rod, in piston, floating, etc.	Locked in rod
	Bushing	In rod or piston
		Material
Clearance	In piston	.0013-.0075 (.00005-.00030)
	In rod	0.0114 (.00045)
Direction & amount offset in piston	Major thrust side-3.302-3.555 (.13-.14) 2.86-2.54 (.09-.10) Major thrust side	

MVMA Specifications Form

Passenger Car

METRIC (U.S. Customary)

Car Line _____
 Model Year 1982 Issued 8-81 Revised (*) _____

Engine Description/Carb. engine Code

4.3 LITER V6 (262 CID)
 FUEL INJECTION DIESEL
 RPO LT6

Engine - Pistons

Material:		Aluminum alloy
Description and finish (flat, dished, dome, etc.):		Autothermic, cam grid Tin plate, steel strut
Mass (weight) (oz) - Piston Only:		.796 kg (28.08)
Clearance (limits):	Top land	0.4318-0.7112 (.017-.028)
	Skirt	Top
		Bottom
Ring groove diameter:	No. 1 ring	91.36-91.62 (3.597-3.607)
	No. 2 ring	91.36-91.62 (3.597-3.607)
	No. 3 ring	91.67-92.13 (3.617-3.627)

Engine - Piston Rings

Function (top to bottom):	No. 1 oil or comp.	Compression
	No. 2 oil or comp.	Compression
	No. 3 oil or comp.	Oil
Compression:	Description - material, coating, etc.	Upper - cast iron with crowned molybdenum filled OD face, granosealed processed Lower - cast iron with tapered face
	Width:	1.96-1.98 (.077-.078)
	Gap:	0.381-0.635 (.015-.025)
Oil:	Description - material, coating, etc.	Rails - spring steel, granoseal processed, chrome plated OD
	Width:	0.595-0.660 (.0235-.0260)
	Gap:	0.38-1.40 (.015-.055)
Expanders:	Spacer - steel spring 601-75	

Engine - Piston Pins

Material:		Steel SAE #1019	
Length:		73.58 (2.897)	
Diameter:		27.82-27.81 (1.0953-1.0949)	
Type:	Locked in rod, in piston, floating, etc.:	Floating	
	Bushing:	In rod or piston:	ROD
		Material:	SAE #791 bronze
Clearance:	In piston:	0.008-0.013 (.0003-.0005)	
	In rod:	0.008-0.033 (.0003-.0013)	
Direction & amount offset in piston:		1.016-1.270 (.040-.050) LH side viewed from front of engine	

MVMA Specifications Form
Passenger Car
METRIC (U.S. Customary)

Car Line MONTE CARLO-MALIBU CLASSIC-EL CAMINO
 Model Year 1982 Issued 8-81 Revised (*) _____

Engine Description/Carb.
 Engine Code

5.7 LITER V8 (350 CID)
 FUEL INJECTION DIESEL
 RPO LF9

Engine - Pistons

Material		Aluminum alloy	
Description and finish (flat, dished, dome, etc.)		Autothermic, cam grind Tin plate, steel strut	
Mass (weight oz.) - Piston Only		.780 kg. (27.5 oz.)	
Clearance (limits)	Top land	.864-1.092 (.034-.043 diametral)	
	Skirt	Top	--
		Bottom	.127-.152 (.005-.006) .75 below piston pin C/L
Ring groove diameter	No 1 ring	91.36-91.62 (3.597-3.607)	
	No 2 ring	91.36-91.62 (3.597-3.607)	
	No 3 ring	91.67-92.13 (3.617-3.627)	

Engine - Piston Rings

Function (top to bottom)	No 1 oil or comp	Compression
	No 2 oil or comp	Compression
	No 3 oil or comp	Oil
Compression	Description - material, coating, etc.	Upper - cast iron with crowned molybdenum filled OD face, granoseal processed Lower - cast iron with tapered OD face
	Width	1.96-1.98 (.077-.078)
	Gap	.381-.635 (.015-.025)
Oil	Description - material, coating, etc.	Rails - spring steel, granoseal processed, chrome plated OD
	Width	(.0235-.0260)
	Gap	(.015-.055)
Expanders	Spacer - steel spring 601-75	

Engine - Piston Pins

Material		Steel SAE #1019 or 1016
Length		73.81 (2.906)
Diameter		27.82-27.81 (1.0953-1.0949)
Type	Locked in rod, in piston, floating, etc.	Floating
	Bushing	In rod or piston
Material		SAE #791 bronze
Clearance	In piston	.008-.013 (.0003-.0005)
	In rod	.008-.033 (.0003-.0013)
Direction & amount offset in piston		NONE

MVMA Specifications Form
Passenger Car
METRIC (U.S. Customary)

Car Line MONTE CARLO-MALIBU CLASSIC-EL CAMILO
 Model Year 1982 Issued 8-81 Revised (*)

Engine Description/Carb. Engine Code	3.6 LITER V6 (229 CID) 2-BBL CARBURETOR RPO LC3	3.6 LITER V6 (231 CID) 2-BBL CARBURETOR RPO LD5
--------------------------------------	---	---

Engine - Connecting Rods

Material	1037 or 1038 steel	Cast arma steel	
Mass, g (weight, oz.)	388 (13.69)	454 (16.01)	
Length (center-to-center)	144.8 (5.70)	151.4 (5.96)	
Bearing	Material & type	Premium aluminum	
	Overall length	17.86-18.11 (.703-.713)	16.61 (.654)
	Clearance (limits)	.025-.063 (.001-.0025)	.013-.066 (.0005-.0026)
	End play	.15-.38 (.006-.015)	.15-.58 (.006-.023)

Engine - Crankshaft

Material	Modular cast iron			
Vibration damper type	Rudder mounted inertia			
End thrust (axial) by bearing (in.)	4	2		
Crankshaft endplay	.051-.152 (.002-.006)	.08-.28 (.003-.011)		
Main bearing	Material & type	#1-666 conecc; #2-4-M400 (a)		
	Clearance	.0508-.0889 (.0020-.0035)	.010-.040 (.0004-.0017)	
	Journal diameter (bearing design)	No 1	62.202x20.37 (2.4489x.802)	63.39x21.95 (2.4955x.864)
		No 2	62.194x20.37 (2.4486x.802)	63.39x26.85 (2.4955x1.057)
		No 3	62.194x20.37 (2.4486x.802)	63.39x21.95 (2.4955x.864)
		No 4	62.139x24.39 (2.4484x1.157)	63.39x21.95 (2.4955x.864)
		No 5	--	--
		No 6	--	--
		No 7	--	--
	Dir & amt. cyl offset			
No. bolts main brg cap	2			

Crankpin journal diameter	53.234-53.335 (2.0978-2.0998)	57.12-57.14 (2.249-2.250)
	(a) #1-upper-M400 conecc; #1 lower-M100 conecc; #2,3-M400; #4-M100	

Engine - Camshaft

Location	in block above crankshaft			
Material	Cast alloy iron			
Bearings	Material	Steel backed babbitt		
	Number	4		
Type of drive	Gear, chain or belt	chain		
	Crankshaft gear or sprocket material	Steel	Sintered iron	
	Cams shaft gear or sprocket material	Cast iron	Aluminum nylon	
	Timing chain	No. of links	54	
		Chain (or belt) pitch	Width	15.07 (.625)
	Pitch		12.7 (.500)	9.53 (.375)

MVMA Specifications Form
Passenger Car
METRIC (U.S. Customary)

Car Line MONTE CARLO-MALIBU CLASSIC-EL CAMINO
 Model Year 1982 Issued 8-81 Revised (*) _____

Engine Description/Carb Engine Code	4.4 LITER V8 (267 CID) 2-BBL CARBURETOR RPO L39	5.0 LITER V8 (305 CID) 4-BBL CARBURETOR RPO L64
--	---	---

Engine - Connecting Rods

Material	1037 or 1038 steel	
Mass, g (weight, oz.)	604.47 (21.32)	604.47 (21.32)
Length (center to center)	144.8 (5.70)	
Bearing	Material & type	Premium aluminum
	Overall length	21.26 (.837)
	Clearance (mm/in)	.033-.089 (.0013-.0035)
	End play	.15-.41 (.006-.016)

Engine - Crankshaft

Material	Nodular cast iron		
Vibration damper type	Rubber mounted inertia		
End thrust taken by bearing (mm)	5		
Crankshaft end play	.051-.178 (.002-.007)		
Main bearing	Material & type	#1-#666 conecc; #2-4-M400; #5 upper M100; #5 lower-M400	
	Clearance	(a)	
	Journal dia and bearing overall length	«No. 1	62.202 x 20.37 (2.4484 x .802)
		«No. 2	62.194 x 20.37 (2.4486 x .802)
		«No. 3	62.194 x 20.37 (2.4486 x .802)
		«No. 4	62.194 x 20.37 (2.4486 x .802)
		«No. 5	62.189 x 38.94 (2.4484 x 1.533)
		«No. 6	--
«No. 7		--	
Dir & amt of cyl offset			
No bolts/cap	2		
Crankpin journal diameter	53.28-53.33 (2.0978-2.0998)		

Engine - Camshaft

Location	In block above crankshaft		
Material	Cast alloy iron		
Bearings	Material	Steel backed babbitt	
	Number	5	
Type of drive	Gear, chain or belt	chain	
	Crankshaft gear or sprocket material	Sintered iron	
	Camshaft gear or sprocket material	Aluminum nylon	
	Timing chain	«No. of links	46
		«Pitch	15.87 (.625)
	Chain or belt	«Pitch	12.7 (.500)

(a) Front - .020-.051 (.0008-.0020)
 Intermediate - .028-.058 (.0011-.0023)
 Rear - .043-.081 (.0017-.0032)

MVMA Specifications Form
Passenger Car
METRIC (U.S. Customary)

Car Line MONTE CARLO MALIBU CLASSIC EL CAMINO
 Model Year 1982 issued 8-81 Revised (*)

Engine Description/Carb. Engine Code 4.3 LITER V6 (262 CID)
FUEL INJECTION DIESEL
RPO LT6

Engine - Connecting Rods

Material		Steel SAE 1140 Mod.
Mass, g (weight, oz.)		0.8835 Kg (31.17 ozs.)
Length (center to center)		149.441 - 149.543
Bearing	Material & type	M400 steel backed
	Overall length	22.38 (.881)
	Clearance (limits)	0.013 - 0.066 (.0005 - .0026)
	End play	0.210 - 0.545 (.008-.021)

Engine - Crankshaft

Material		Nodular iron	
Vibration damper type		None	
End thrust taken by bearing (in.)		#3	
Crankshaft end play		0.089 - 0.343 (.0035 - .0135)	
Main bearing	Material & type	M400 steel backed	
	Clearance		
	Journal dia and bearing overall length	No 1	76.2 x 24.8 (3.00 x .975)
		No 2	76.2 x 24.8 (3.00 x .975)
		No 3	76.2 x 25.7 (3.00 x 1.010)
		No 4	76.2 x 32.3 (3.00 x 1.270)
		No 5	--
		No 6	--
No 7		--	
Dir & amt cyl offset		Left bank 32.00 (1.260) ahead of right bank	
No bolts-main brg cap		2 per cap	
Crankpin journal diameter		57.120-57.145 (2.2488-2.2498)	

Engine - Camshaft

Location		Center
Material		Forged steel
Bearings	Material	M100 steel backed
	Number	4
Type of drive	Gear, chain or belt	
	Chain	
	Crankshaft gear or sprocket material	
	Steel SAE #1117	
	Camshaft gear or sprocket material	
	Cast iron GM 85-M	
Timing chain	No of links	
	48	
Chain or belt	Width	14.48 (.570)
	Pitch	12.7 (.500)

MVMA Specifications Form
Passenger Car
METRIC (U.S. Customary)

Car Line MONTE CARLO-MALIBU CLASSIC-EL CAMINO
 Model Year 1982 Issued 8-81 Revised (*) _____

Engine Description/Carb. Engine Code	5.7 LITER V8 (350 CID) FUEL INJECTION DIESEL RPO LF9
---	--

Engine - Connecting Rods

Material	Steel SAE #1140	
Mass, g (weight, oz.)		
Length (center to center)	149.54 - 149.44 (5.8875 - 5.8835)	
Bearing	Material & type	Moraine 400 Steel backed
	Overall length	20.85 - 21.11 (.821 - .931)
	Clearance (limits)	.013 - .066 (.0005 - .0026)
	End play	.15 - .51 (.0067-.020)

Engine - Crankshaft

Material	Nodular iron		
Vibration damper type	Tuned rubber		
End thrust taken by bearing (in.)	#3		
Crankshaft end play	.089-.343 (.0035-.0135)		
Main bearing	Material & type	(1)	
	Clearance		
	Journal dia and bearing overall length	No 1	76.2 x 24.77 (3.00 x .975)
		No 2	76.2 x 24.77 (3.00 x .975)
		No 3	76.2 x 30.53 (3.00 x 1.194)
		No 4	76.2 x 24.77 (3.00 x .975)
		No 5	76.2 x 41.25 (3.00 x 1.624)
		No 6	--
No 7		--	
Dir & amt cyl offset	22.83 (left bank .938 ahead of Rt. bank)		
No bolts main brg cap	2 per cap		
Crankpin journal diameter	53.945 - 53.970 (2.1238 - 2.1248)		

Engine - Camshaft

Location	Center	
Material	Forged Steel	
Bearings	Material	GM-4167-M or GM-3381-M
	Number	5
Type of drive	Gear, chain or belt	Chain
	Crankshaft gear or sprocket material	SAE #1117
		Steel
	Camshaft gear or sprocket material	GM 85-M
		Cast Iron
Timing chain	No. of links	48
Chain or belt	Width	14.48 (.570)
	Pitch	12.7 (.500)

(1) #1,2,3,4,5, upper and #5 lower - Moraine 100, steel backed
 #1,2,3,4 lower - Moraine 400, steel backed

MVMA Specifications Form
Passenger Car
METRIC (U.S. Customary)

Car Line MONTE CARLO-MALIBU CLASSIC-EL CAMINO
 Model Year 1982 Issued 8-81 Revised (*) _____

Engine Description/Carb
 Engine Code

3.8 LITER V6 (229 CID) 2-BBL. CARBURETOR RPO LC3	3.8 LITER V6 (231 CID) 2-BBL. CARBURETOR RPO LD5
--	--

Engine - Valve System

Hydraulic lifters (std opt na)	Standard			
Valve rotator type (intake exhaust)	Exhaust	None		
Push rods (dia length material)	7.9x196.2 (.3125x7.724) (a)	7.94x220.9 (.3125x7.9) (b)		
Rocker ratio	1.50:1			
Operating tappet clearance (indicate hot or cold)	Intake	Zero		
	Exhaust	Zero		
Timing based on top of comp point	Intake	Opens (BTC)	42	16
		Closes (BTC)	78	63
		Duration (deg)	300	259
	Exhaust	Opens (BTC)	78	68
		Closes (BTC)	52	29
		Duration (deg)	310	277
Valve open overlap (deg)	94	45		
Intake valve	Material	SAE-1541 or 1547 (c)	1541 steel, chrome flash stem	
	Overall length	124.52-125.03(4.9024-4.9224)	199.33-120.09(4.698-4.728)	
	Actual overall head dia	46.7 (1.84)	43.43 (1.710)	
	Angle of seat & face (deg)	46,45	45	
	Seat insert material	None	None	
	Stem diameter	8.661-8.679 (.3410-.3417)	8.64-8.66 (.3402-.3412)	
	Stem to guide clearance	.025-.069 (.0010-.0027)	.038-.089 (.0015-.0035)	
	Initial zero lash	9.07 (.357)	9.09 (.358)	
	Outer spring press & length	Valve closed - N at mm (lb at in)	338-374 @ 43.2 (76-84 @ 1.70)	262-307 @ 43.86 (59-69 @ 1.727)
		Valve open - N at mm (lb at in)	872-916@31.7 (194-206 @ 1.25)	774-845 @ 34 (174-190 @ 1.34)
	Inner spring press & length	Valve closed - N at mm (lb at in)	Spring damper	
		Valve open - N at mm (lb at in)	Spring damper	
	Exhaust valve	Material	21-2N Steel, chrome flash stem	
Overall length		124.71-125.02 (4.910-4.930)	119.46-120.22 (4.703-4.733)	
Actual overall head dia		38.1 (1.50)		
Angle of seat & face (deg)		46, 45	45	
Seat insert material		None	None	
Stem diameter		8.661-8.679 (.3410-.3417)	8.649-8.666 (.3405-.3412)	
Stem to guide clearance		.025-.069 (.0010-.0027)	.038-.081 (.0015-.0032)	
Initial zero lash		9.91 (.390)	9.30 (.366)	
Outer spring press & length		Valve closed - N at mm (lb at in)	338-374 @ 43.2 (76-84 @ 1.70)	262 - 307 @ 43.9 (59-69 @ 1.73)
		Valve open - N at mm (lb at in)	872-916@31.7 (194-206@1.25)	774-845@34.0 (174-190@1.34)
Inner spring press & length		Valve closed - N at mm (lb at in)	Spring damper	
		Valve open - N at mm (lb at in)	Spring damper	

(a) welded steel tubing.
 (c) Chrome flash stem.

(b) .060" wall steel tubing.

MVMA Specifications Form
Passenger Car
METRIC (U.S. Customary)

Car Line MONTE CARLO-MALIBU CLASSIC-EL CAMINO
 Model Year 1982 Issued 8-81 Revised (*) _____

Engine Description/Carb.
 Engine Code

4.4 LITER V8 (267 CID) 2-BBL. CARBURETOR RPO 139	5.0 LITER V8 (305 CID) 4-BBL. CARBURETOR RPO 1G4
--	--

Engine - Valve System

Hydraulic lifters (std. opt. n.a.)		Standard		
Valve rotator type (intake exhaust)		Exhaust		
Push rods (dia. length material)		7.9x196.2 (.3125x7.724) welded steel tubing		
Rocker ratio		1.50:1		
Operating tappet clearance (indicate hot or cold)	Intake	Zero		
	Exhaust	Zero		
Timing (based on top of ramp points)	Intake	Opens (°BTC)	44	
		Closes (°BTC)	76	
		Duration (deg)	300	
	Exhaust	Opens (°BTC)	78	
		Closes (°BTC)	52	
		Duration (deg)	310	
Valve open overlap (deg)		96		
Intake valve	Material		SAE-1541 - H Steel	
	Overall length		124.52-125.03 (4.9024-4.9224)	
	Actual overall head dia		43.7 (1.72) 46.7 (1.84)	
	Angle of seat & face (deg)		46, 45	
	Seat insert material		None	
	Stem diameter		8.661-8.679 (.3410-.3417)	
	Stem to guide clearance		.025-.069 (.0010-.0027)	
	Lift (at zero lash)		9.07 (.357)	
	Outer spring press & length	Valve closed - N at mm (lb at in)	338-374 @ 43.2 (76-84 @ 1.70)	
		Valve open - N at mm (lb at in)	863-916 @ 31.75 (194-206 @ 1.25)	
	Inner spring press & length	Valve closed - N at mm (lb at in)	Spring damper	
		Valve open - N at mm (lb at in)	Spring damper	
	Exhaust valve	Material		21-2N steel, chrome flash stem
		Overall length		124.71-125.02 (4.910-4.930)
		Actual overall head dia		35.1 (1.38) 38.1 (1.50)
Angle of seat & face (deg)		46, 45		
Seat insert material		None		
Stem diameter		8.661-8.679 (.3410-.3417)		
Stem to guide clearance		.025-.069 (.0010-.0027)		
Lift (at zero lash)		9.91 (.3900)		
Outer spring press & length		Valve closed - N at mm (lb at in)	338-374 @ 43.2 (76-84 @ 1.70)	
		Valve open - N at mm (lb at in)	863-916 @ 31.75 (194-206 @ 1.25)	
Inner spring press & length		Valve closed - N at mm (lb at in)	Spring damper	
		Valve open - N at mm (lb at in)	Spring damper	

MVMA Specifications Form
Passenger Car
METRIC (U.S. Customary)

Car Line MONTE CARLO-MALIBU CLASSIC-FI CAMINO
 Model Year 1982 issued 8-81 Revised (*)

Engine Description/Code
 Engine Code

4.3 LITER V6 (262 CID)
 FUEL INJECTION DIESEL
 RPO LT6

Engine - Valve System

Hydraulic lifters (std. opt. in a)		Hydraulic roller lifters - standard		
Valve rotator, type (intake exhaust)		Helical spring & flat washer type (int. & exhaust)		
Push rods (dia. length, material)		9.53 (.375) steel balls welded to 7.98 (.314 tubing-106.1)		
Rocker ratio		1.6:1 (7.72) overall		
Operating tappet clearance (indicate hot or cold)	Intake	Zero		
	Exhaust	Zero		
Timing (based on top of ramp points)	Intake	Opens (°BTC)	16°	
		Closes (°BTC)	38°	
		Duration (deg)	234°	
	Exhaust	Opens (°BTC)	64°	
		Closes (°BTC)	17°	
		Duration (deg)	261°	
Valve stem overlap (deg)		33°		
Intake valve	Material		Steel 21-2 (chrome flashed stem)	
	Overall length		127.468 (5.018)	
	Actual overall head dia		47.0 (1.850)	
	Angle of seat & face (deg)		45° seat 46° face	
	Seat insert material			
	Stem diameter		6.717-8.700 (.3432-.3425)	
	Stem to guide clearance		0.025-0.069 (.0010-.0027)	
	Lift (at zero lash)		9.53 (.375)	
	Outer spring press & length	Valve closed - N at mm (lb at in)	378 - 423 @ 42.40 (84.98 - 95.10 @ 1.670)	
		Valve open - N at mm (lb at in)	810.8 - 869.8 @ 33.02 (182.28 - 195.55 @ 1.300)	
	Inner spring press & length	Valve closed - N at mm (lb at in)	--	
		Valve open - N at mm (lb at in)	--	
	Exhaust valve	Material		Steel 21-2 chrome flashed stem
		Overall length		127.699 (5.0275)
Actual overall head dia		41.32 - 41.07 (1.627-1.617)		
Angle of seat & face (deg)		59° seat 60° face		
Seat insert material				
Stem diameter		8.705 - 8.687 (.3427 - .3420)		
Stem to guide clearance		0.038 - 0.081 (.0015 - .0032)		
Lift (at zero lash)		9.55 (.375)		
Outer spring press & length		Valve closed - N at mm (lb at in)	378 - 423 @ 42.40 (84.98 - 95.10 @ 1.670)	
		Valve open - N at mm (lb at in)	810.8 - 869.8 @ 33.02 (182.28 - 195.55 @ 1.300)	
Inner spring press & length		Valve closed - N at mm (lb at in)	--	
		Valve open - N at mm (lb at in)	--	

MVMA Specifications Form
Passenger Car
METRIC (U.S. Customary)

Make/Model: MONTE CARLO-MALIBU CLASSIC-EL CAMINO
 Model Year: 1982 Issue: 8-81 Revised (*): _____

Engine Description/Cat#
 Engine Code

5.7 LITER V8 (350 CID)
 FUEL INJECTION DIESEL
 RPO LF9

Engine - Valve System

Hydraulic lifters (std. opt. n.a.)		Standard-Roller Lifter		
Valve rotator type (intake/exhaust)		Helical spring & flat washer type (Intake & exhaust)		
Push rods (dia. length material)		9.525 x 210.00 (.375 diameter x 8.267)		
Rocker ratio		1.6:1		
Operating tappet clearance (indicate not applicable)	Intake	Zero		
	Exhaust	Zero		
Timing based on top of ramp points	Intake	Opens (°BTC)	16°	
		Closes (°BTC)	38°	
		Duration (deg)	234°	
	Exhaust	Opens (°BTC)	64°	
		Closes (°BTC)	17°	
		Duration (deg)	261°	
Valve open overlap (deg)		33°		
Intake Valve	Material		Steel 21-2 (chrome flashed stem)	
	Overall length		127.470 (5.0185)	
	Actual overall head dia		47.498 - 47.752 (1.870-1.880)	
	Angle of seat & face (deg)		45° seat; 46° face	
	Seat insert material			
	Stem diameter		8.717-8.700 (.34327-.3425)	
	Stem to guide clearance		.025-.069 (.0010/.0027)	
	Lift (at zero lash)		9.53 (.375)	
	Outer spring press & length	Valve closed - N at mm (lb at in)	342.5-369.2 @ 42.42 (77-83 @ 1.670)	
		Valve open - N at mm (lb at in)	640.5-702.8 @ 33.02 (144-158 @ 1.300)	
	Inner spring press & length	Valve closed - N at mm (lb at in)	--	
		Valve open - N at mm (lb at in)	--	
	Exhaust Valve	Material		Steel 21-2 chrome flashed stem
Overall length		127.699 (5.0275)		
Actual overall head dia		41.32 - 41.07 (1.627/1.617)		
Angle of seat & face (deg)		59° seat; 60° face		
Seat insert material		--		
Stem diameter		8.705-8.687 (.3427/.3420)		
Stem to guide clearance		.038 - .081 (.0015/.0032)		
Lift (at zero lash)		9.55 (.376)		
Outer spring press & length		Valve closed - N at mm (lb at in)	342.5-369.2 @ 42.42 (77-83 @ 1.670)	
		Valve open - N at mm (lb at in)	640.5-702.8 @ 33.02 (144-158 @ 1.300)	
Inner spring press & length		Valve closed - N at mm (lb at in)	--	
		Valve open - N at mm (lb at in)	--	

MVMA Specifications Form
Passenger Car
METR: (U.S. Customary)

Car Line MONTE CARLO-MALIBU CLASSIC-EL CAMINO
 Model Year 1982 issued 8-81 Revised (*) _____

Engine Description/Carb.
 Engine Code

3.8 LITER V6 (229 CID)
 2-BBL. CARBURETOR
 RPO 1C3

3.8 LITER V6 (231 CID)
 2-BBL CARBURETOR
 RPO 1D5

Engine - Lubrication System

Type of lubrication (splash, pressure, nozzle)	Main bearings	Pressure
	Connecting rods	Pressure
	Piston pins	Splash
	Camshaft bearings	Pressure
	Tappets	Pressure
	Timing gear or chain	Splash & Nozzle
	Cylinder walls	Splash
Oil pump type	Gear	
Normal oil pressure - kPa (psi) at engine rpm	345-448 (50-65) @ 2000	
Type oil intake (floating, stationary)	Stationary	
Oil filter system (full flow, part, other)	Full flow	
Capacity of c/case, less filter-refill-L (qt)	3.8 (4.0)	
Oil grade recommended (SAE viscosity and temperature range)	Minus 6.6°C(20°F) & Above 20W-20, 10W-30, 10W-40, 20W-40, 20W-50, Minus 17.7°C to +15.5°C 10W, 5W-30, 10W-40, 10W-30. (0 to 60° F) Minus 6.6°C(20°F) & Below 5W-20, 10W-30	
Engine service reqmt (SD, SE, etc)	SF	

Engine - Exhaust System

Type (single, single with cross-over, dual, other)	Single w/crossover	
Muffler no. & type (reverse flow, straight thru, separate resonator)	One, reverse flow	
Resonator no. & type	None	
Exhaust pipe	Branch O.D. wall thickness	50.8 x 1.15 (2.0 x .045) 50.8 x .8 (2.0 x .03)
	Main O.D. wall thickness	57.15 x 1.02 (2.25 x .040)
	Material	Laminated - stainless steel outer, steel inner.
Inter-mediate pipe	O.D. & wall thickness	50.8 x 1.09 (2.0 x .043)
	Material	Aluminum coated tubing
Tail pipe	O.D. & wall thickness	50.8 x 1.39 (2.0 x .055)
	Material	Aluminum coated tubing

MVMA Specifications Form
Passenger Car
METRIC (U.S. Customary)

Car Line MONTE CARLO-MALIBU CLASSIC-EL CAMINO
 Model Year 1982 Issued 8-81 Revised (*)

Engine Description/Carb.
 Engine Code

4.4 LITER V8 (267 CID) 2-BBL CARBURETOR RPO L39	5.0 LITER V8 (305 CID) 4-BBL CARBURETOR RPO L64
---	---

Engine -- Lubrication System

Type of lubrication (splash, pressure, nozzle)	Main bearings	Pressure	
	Connecting rods	Pressure	
	Piston pins	Splash	
	Camshaft bearings	Pressure	
	Tappets	Pressure	
	Timing gear or chain	Splash & Nozzle	Centrifugally oiled
	Cylinder walls	Splash	Pressure
Oil pump type	Gear		
Normal oil pressure-kPa (psi) at engine rpm	310 (45)		
Type oil intake (floating, stationary)	Stationary		
Oil filter system (full flow, part, other)	Full flow		
Capacity of c/case, less filter-refill-L (qt.)	3.8 (4.0)		
Oil grade recommended (SAE viscosity and temperature range)	Minus 6.6°C (20°F) & Above 20W-2D, 10W-30, 10W-40, 20W-40, 20W-50. Minus 17.7°C to +15.5°C (0 to 60°F) 10W, 5W-30, 10W-40, 10W-30. Minus 6.6°C (20°F) & Below 5W-2D, 10W-30.		
Engine service reqmt (SD, SE, etc.)	SF		

Engine -- Exhaust System

Type (single, single with cross-over, dual, other)	Single w/crossover		
Muffler no. & type (reverse flow, straight thru, separate resonator)	One reverse flow		
Resonator no & type	none		
Exhaust pipe	Branch O.D. wall thickness	50.8 x 1.02 (2.0 x .04)	
	Main O.D. wall thickness	57.15 x 1.8 (2.25 x .07)	
	Material	Laminated - stainless steel outer, steel inner *	
Inter-mediate pipe	O.D & wall thickness	50.8 x 1.08 (2.0 x .043)	57.15 x 1.1 (2.25 x .043)
	Material	Laminated steel tubing @	
Tail pipe	O.D. & wall thickness	50.8 x 1.39 (2.0 x .055)	57.15 x 1.39 (2.25 x .055)
	Material	Aluminum coated tubing	

- * - Branch - main, stainless steel tubings
- @ - Outer tubing aluminum coated for El Camino only.

MVMA Specifications Form
Passenger Car
METRIC (U.S. Customary)

Car Line MONTE CARLO-MALIBU CLASSIC-EL CAMINO
 Model Year 1982 Issued 8-81 Revised (*) _____

Engine Description/Carb.
 Engine Code

5.7 LITER V8 (350 CID) FUEL INJECTION DIESEL RPO LF9	4.3 LITER V6 (262 CID) FUEL INJECTION DIESEL RPO LT6
--	--

Engine - Lubrication System

Type of lubrication (splash pressure, nozzle)	Main bearings	Pressure
	Connecting rods	Pressure
	Piston pins	Spray
	Camshaft bearings	Pressure
	Tappets	Pressure
	Timing gear or chain	Spray
	Cylinder walls	Spray
Oil pump type	Gear	
Normal oil pressure-kPa (psi) at engine rpm	(30-45 @ 1500 RPM)	
Type oil intake (floating, stationary)	Stationary	
Oil filter system (full flow, part, other)	Full Flow	
Capacity of c/case, less filter-refill-L (qt)	6.0L (6.5 Quarts)	
Oil grade recommended (SAE viscosity and temperature range)	See Below	
Engine service reqmt (SD SE, etc)	SF/CC, SF/CD/ SE/CC	

Engine - Exhaust System

Type (single, single with cross-over, dual, other)	Single with cross-over		
Muffler no. & type (reverse flow, straight thru, separate resonator)	Reverse flow		
Resonator no. & type	(1) straight thru		
Exhaust pipe	Branch OD, wall thickness	Federal California	LT-6
	Main OD, wall thickness	57.15x1.4(2.5x.06) 63.50x1.07(2.5x.04)	57.15x1.09
	Material	Alum. coated steel	Laminated pipe-low carbon steel
Inter-mediate pipe	OD & wall thickness	57.15x1.07(2.5x.04)	50.8x1.09
	Material	Laminated pipe low carbon steel	
Tail pipe	OD & wall thickness	44.5 x 1.4 (1.75 x .06)	
	Material	Steel SAE 1009 welded tubing alum. coated	

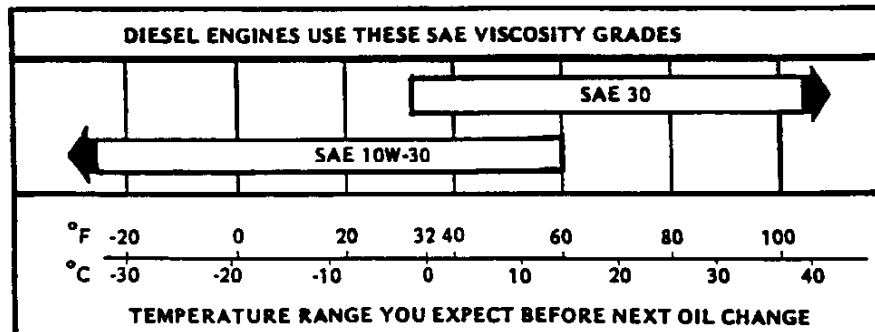

MVMA Specifications Form
Passenger Car
METRIC (U.S. Customary)

Car Line MONTE CARLO-MALIBU CLASSIC-EL CAMINO
 Model Year 1982 Issued 8-81 Revised (*) 10-81

Engine Description/Carb.
 Engine Code

3.8 LITER V6 (229 CID) 2-BBL. CARBURETOR RPO LC3	3.8 LITER V6 (231 CID) 2-BBL. CARBURETOR RPO LD5
--	--

Engine - Fuel System (See supplemental page for details of Fuel Injection, Supercharger, Turbocharger, etc. if used)

Induction type carburetor, fuel injection system, etc		Carburetor		
Fuel tank	Refill capacity - L (US gals)	69.0 (18.1) Sed & Monte Carlo; 69.0 (18.2) S.W.; 67.0 (17.7) El Camino		
	Filler location	Sedan & Monte Carlo-Rear; S.W. & El Camino-IR quarter panel.		
Fuel pump	Type (elec or mech)	Mechanical		
	Locations	Lower right front	Lower left front	
	Pressure range - kPa (psi)	31-41 (4.5 - 6.0)	29-40 (4.25 - 5.75)	
Carburetor	Mfg & model	Rochester 17081130, 31	17081198	
	Choke type	Electric		
	Intake manifold heat control (exhaust or water)	Exhaust		
	Air cleaner type	Standard	Replaceable paper element, single snorkel	
		Optional	--	
	Idle spd -rpm (spec neutral or drive)	Manual	700	--
		Propane (neu)		
Automatic		600	500	
Idle A/F mix				

Engine - Diesel Information

Glow plug		
Injector nozzle	Type	
	Opening pressure - kPa (psi)	
Pre-chamber design		
Fuel injection pump	Manufacturer	
	Type	
Supplementary vacuum source (type)		

MVMA Specifications Form
Passenger Car
METRIC (U.S. Customary)

Car Line MONTE CARLO MALIBU CLASSIC EL CAMINO
 Model Year 1982 Issued 8-81 Revised (*) 10-81

Engine Description/Carb. Engine Code	4.4 LITER V8 (267 CID) 2-BBL. CARBURETOR RPO L39	5.0 LITER V8 (305 CID) 4-BBL. CARBURETOR RPO LG4
---	--	--

Engine - Fuel System (See supplemental page for details of Fuel injection, Supercharger, Turbocharger, etc. if used)

Induction type carburetor, fuel injection system, etc		Carburetor		
Fuel tank	Refill capacity - L (US gals)	69.0 (18.1) Sed & Monte Carlo; 69.0 (18.2) S.W.; 67.0 (17.7) El Camino		
	Filler location	Sedan & Monte Carlo-Rear; S.W. & El Camino-IR quarter panel.		
Fuel pump	Type (elec or mech)	Mechanical		
	Locations	Lower right front		
	Pressure range - kPa (psi)	38.0-48.5 (5.5 - 7.0)		
Carburetor	Make & model	Rochester 17081138	17081202	
	Choke type	Electric		
	Intake manifold heat control (exhaust or water)	Exhaust		
	Air cleaner type	Standard	Replaceable paper & charcoal element, single snorkel	
		Optional	--	
Idle spd -rpm (spec neutral or drive)	Manual			
	Propane (neu.)			
	Automatic	500		
Propane (neu.)				
Idle A/F mix				

Engine - Diesel Information

Glow plug		
Injector nozzle	Type	
	Opening pressure - kPa (psi)	
Pre-chamber design		
Fuel injection pump	Manufacturer	
	Type	
Supplementary vacuum source (type)		

MVMA Specifications Form
Passenger Car
METRIC (U.S. Customary)

Car Line MONTE CARLO-MALIBU CLASSIC-EL CAMINO
 Model Year 1982 Issued 8-81 Revised (*) 10-81

Engine Description and Carb. Engine Code	5.7 LITER V8 (350 CID) FUEL INJECTION DIESEL RPO LF9	4.3 LITER V6 (262 CID) FUEL INJECTION DIESEL RPO LT6
--	--	--

Engine - Fuel System (See supplemental page for details of Fuel injection, Supercharger, Turbocharger, etc. if used)

Induction type carburetor, fuel injection system, etc.		Fuel Injection		
Fuel tank	Refill capacity - L (U.S. gals)	75.0 (19.8) Coupe/Sedan; 69.0(18.2) Station Wagon		
	Filler location	Rear ctr - coupe/SEDAN, left rear quarter - wagon		
Fuel pump	Type (elec or mech)	Mechanical	Electrical	
	Location	Right Front Engine	Side of engine	
	Pressure range - kPa (psi)	37.92 - 44.82 KPA (5.5 - 6.5 PSI)		
Carburetor	Migr. type	--		
	Choke type	--		
	Intake manifold heat control (exhaustor water)	--		
	Air cleaner type	Standard	Oil Wetted Paper Element	
		Optional	--	
Idle speed (spec neutral or drive)	Manual	--		
	Propane (neu)	--		
	Automatic	In Drive		
Propane (neu)	--			
Idle A/F mix	--			

Engine - Diesel Information

Glow plug	Control System	Fast Glow	
Injector nozzle	Type	Poppet	
	Opening pressure - kPa (psi)	8450 +/- 690 (1225 +/- 100 PSI), V6 see below	
Pre-chamber design	Side Exit		
Fuel injection pump	Manufacturer	Stanadyne	Stanadyne/CAV
	Type	DB2	
Supplementary vacuum source (type)	Mechanical Pump	Electrical	
6900 Kpa */ - 690 (1000 +/- 100			

MVMA Specifications Form
Passenger Car
METRIC (U.S. Customary)

Car Line MONTE CARLO-MALIBU CLASSIC-EL CAMINO
 Model Year 1982 Issued 8-81 Revised (*) _____

Engine Description/Carb.
 Engine Code

3.8 LITER V6 (229 CID) 2 -BBL. CARBURETOR RPO LC3	3.8 LITER V6 (231 CID) 2-BBL. CARBURETOR RPO LD5
--	--

Engine - Cooling System

Coolant recovery system (std., opt., none)		Standard	
Radiator cap relief valve pressure—kPa(PSI)		103.4 (15.0)	
Circulation thermostat	Type (choke, bypass)	Choke	
	Starts to open at °C (°F)	90.6 (195)	
Water pump	Type (centrifugal, other)	Centrifugal	
	GPM 1000 pump rpm		
	Number of pumps	One (1)	
	Drive (V-belt, other)	V-Belt	
Bearing type		Sealed double row ball	
By-pass recirculation type (inter., ext.)		Internal	External
Radiator core type (cross-flow vertical, cellular, tube and fin, other)		Cross flow, tube & center	
Cooling system capacity	With heater—L(qt) (*)	11.38 (15.19)	11.75 (12.42)
	Without heater—L(qt.)	Heater standard equipment	
	Opt. equipment—specify—L(qt.)	11.27 (15.08)	11.50 (12.15)
Water jackets full length of cyl. (yes, no)		Yes	
Water all around cylinder (yes, no)		Yes	
Radiator (hose)	Lower	Number and type (molded, straight)	One, molded
		Inside diameter	38.1 (1.50)
	Upper	Number and type (molded, straight)	One molded
		Inside diameter	31.8 (1.25)
	By-pass	Number and type (molded, straight)	None
		Inside diameter	—
Radiator (core)	Standard	Width	528.3 (20.8)
		Height	431.0 (16.97)
		Thickness	31.5 (1.24)
	A/C	Width	528.3 (20.8)
		Height	431.0 (16.97)
		Thickness	31.5 (1.24)
	Heavy duty	Width	528.3 (20.8)
		Height	431.0 (16.97)
		Thickness	31.5 (1.24)
Fan (standard)	Number of blades & type - flex/solid		4, staggered
	Diameter		483 (19.0)
	Ratio — fan to crankshaft rev.		—
	Fan cutout type		None
	Drive type-number of fans		V-Belt-one
Fan (optional)	No. of blades and spacing		5, staggered
	Diameter		483 (19.0)
	Ratio — fan to crankshaft rev.		—
	Fan cut-out type		Clutch
	Drive type-number of fans		V-Belt-one

MVMA Specifications Form
Passenger Car
METRIC (U.S. Customary)

Car Line MONTE CARLO-MALIBU CLASSIC-EL CAMINO
 Model Year 1982 Issued 8-81 Revised (*) _____

Engine Description/Carb.
 Engine Code

4.4 LITER V8 (267 CID) 2-BBL. CARBURETOR RPO L39	5.0 LITER V8 (305 CID) 4-BBL. CARBURETOR RPO LG4
--	--

Engine -- Cooling System

Coolant recovery system (std., opt., none)		Standard	
Radiator cap relief valve pressure—kPa(psi)		103.4 (15.0)	
Circulation thermostat	Type (choke, bypass)	Choke	
	Starts to open at °C (°F)	91 (195)	
Water pump	Type (centrifugal, other)	Centrifugal	
	GPM 1000 pump rpm		
	Number of pumps	One	
	Drive (V-belt, other)	V-Belt	
	Bearing type	Sealed double row ball	
By-pass recirculation type (inter., ext.)		Internal	
Radiator core type (cross-flow vertical, cellular, tube and fin, other)		Cross flow, tube & center	
Cooling system capacity	With heater—L(qt.)	17.95 (18.87)	15.68 (16.57)
	Without heater—L(qt.)	Heater standard equipment	
	Opt. equipment-specify—L(qt.)	17.30 (18.07)	15.62 (16.50)
Water jackets full length of cyl. (yes, no)		Yes	
Water all around cylinder (yes, no)		Yes	
Radiator (nose)	Lower	Number and type (molded, straight)	One molded
		Inside diameter	38.9 (1.50)
	Upper	Number and type (molded, straight)	One molded
		Inside diameter	31.8 (1.25)
	By-pass	Number and type (molded, straight)	None
		Inside diameter	--
Radiator (core)	Standard	Width	668.0 (26.3)
		Height	429.7 (16.84)
		Thickness	25.0 (.98)
	A/C	Width	668.0 (26.3)
		Height	429.7 (16.84)
		Thickness	25.0 (.98)
	Heavy duty	Width	668.0 (26.3)
		Height	429.7 (16.84)
		Thickness	25.0 (.98)
Fan (standard)	Number of blades & type - flex/solid		4, staggered
	Diameter		483 (19.0)
	Ratio — fan to crankshaft rev.		--
	Fan cutout type		None
	Drive type-number of fans		V-Belt-one
Fan (optional)	No. of blades and spacing		5, staggered
	Diameter		483 (19.0)
	Ratio — fan to crankshaft rev.		--
	Fan cut-out type		Clutch
	Drive type-number of fans		V-Belt-one

MVMA Specifications Form

Passenger Car

METRIC (U.S. Customary)

Car Line _____

Model Year 1982 Issued 8-81 Revised (*) 10-81

Engine Description/Carb.
Engine Code

4.3 LITER V6 (262 CID)
FUEL INJECTION DIESEL
RPO LT6

5.7 LITER V8 (350 CID)
FUEL INJECTION DIESEL
RPO LF9

Engine - Cooling System

Coolant recovery system (std., opt., none)		Standard		
Radiator cap relief valve pressure - kPa(PSI)		15 PSI		
Circulation thermostat	Type (choke, bypass)	By-Pass		
	Starts to open at °C (°F)	91°C - 195°F		
Water pump	Type (centrifugal, other)	Centrifugal		
	GPM 1000 pump rpm	22 GPM		
	Number of pumps	1		
	Drive (V-belt, other)	Serpentine		
Bearing type		Ball		
By-pass recirculation type (inter., ext.)		External		
Radiator core type (cross-flow vertical, cellular, tube and fin, other)		Cross-flow		
Cooling system capacity	With heater - L(qt.)	Not available		
	Without heater - L(qt.)	Not available		
	Opt. equipment-specify - L(qt.)	Not available		
Water jackets full length of cyl. (yes, no)		Yes		
Water all around cylinder (yes, no)		Yes		
Radiator (hose)	Lower	Number and type (molded, straight)	One molded	
		Inside diameter	38.1 (1.50)	
	Upper	Number and type (molded, straight)	One molded	
		Inside diameter	31.8 (1.25)	
	By-pass	Number and type (molded, straight)	One straight	
		Inside diameter	19.3/17.8 (.76/.70)	
Radiator (core)	Standard	Width	668 (26.3)	
		Height	430 (17.0)	
		Thickness	40.2 (1.58)	
	A/C	Width	668 (26.3)	
		Height	430 (17.0)	
		Thickness	40.2 (1.58)	
	Heavy duty	Width	668 (26.3)	
		Height	430 (17.0)	
		Thickness	40.2 (1.58)	
Fan (standard)	Number of blades & type - flex/solid		5, staggered	
	Diameter		483 (19.0)	
	Ratio - fan to crankshaft rev		1.40	
	Fan cutout type		Clutch	
Drive type-number of fans		V-Belt-One		
Fan (optional)	No. of blades and spacing		5, staggered	
	Diameter		483 (19.0)	
	Ratio - fan to crankshaft rev		1.22	1.40
	Fan cut-out type		Clutch	
Drive type-number of fans		V-Belt-One		

LT6 - C41 = 13.8L(14.6), C60/C65/V08 = 14.5L(15.3)
LF9 - C41 = 16.5L(17.4), C60/C65/V08 = 16.4L(17.3)

MVMA Specifications Form
Passenger Car
METRIC (U.S. Customary)

Car Line MONTE CARLO-MALIBU CLASSIC-EL CAMINO
 Model Year 1982 Issued 8-81 Revised (*) _____

Engine Description/Carb.
 Engine Code

3.8 LITER V6 (229 CID) 2-BBL. CARBURETOR RPO LC3	3.8 LITER V6 (231 CID) 2-BBL. CARBURETOR RPO LD5
--	--

Vehicle Emission Control

Exhaust Emission Control	Type (air injection, engine modifications, other)		Air Injection w/Computer Command Control		
	Air Injection Pump	Type			
		Displacement—cm ³ (in ³)			
		Drive ratio			
		Drive type			
		Relief valve (type)			
		Filter (describe)			
	Air Injection System	Air distribution (head, manifold, etc.)	Manifold, converter	Exhaust pipe	
		Point of entry	Inlet manifold	Exhaust pipe	
		Injection tube id	6.65 (.262)		
		Check valve type	Pressure plate system		
		Backfire protection (type)	Diverter valve		
	Exhaust Gas Recirculation System	Type (controlled flow, open orifice, other)	Controlled flow		
		Valve type	Vacuum modulated shut-off & metering valve		
		Valve location	Inlet manifold		
Control energy source		Carburetor vacuum			
Exhaust source		Manifold exhaust crossover			
Exhaust cooler type		None			
Orifice no. and size		One			
Catalytic Converter System	Catalyst	Type	Platinum - Palladium - Rhodium		
		Volume—L(in ³)	4.0 (244)(a)		
	Substrate type	Dual bed (b)			
	Container location	Beneath RF underbody			
Other	Carburetor Hot Air		Thermostatically controlled air cleaner regulates and mixes heated air with incoming cold air to reduce hydrocarbon emissions.		

(a) Catalysts - Volume LD5 engine 4.261 (260)
 (b) Single bed for LD5 engine

MVMA Specifications Form
Passenger Car
METRIC (U.S. Customary)

Car Line MONTE CARLO-MALIBU CLASSIC-EL CAMINO
 Model Year 1982 issued 8-81 Revised (*) _____

Engine Description/Carb.
 Engine Code

4.4 LITER V8 (267 CID) 2-BBL. CARBURETOR RPO L39	5.0 LITER V8 (305 CID) 4-BBL. CARBURETOR RPO L64
--	--

Vehicle Emission Control

Exhaust Emission Control	Type (air injection, engine modifications, other)		Air Injection w/Computer Command Control
	Air Injection Pump	Type	
		Displacement—cm ³ (in ³)	
		Drive ratio	
		Drive type	
		Relief valve (type)	
		Filter (describe)	
	Air Injection System	Air distribution (head, manifold, etc.)	Exhaust pipe
		Point of entry	Exhaust pipe
		Injection tube i.d.	6.65 (.262)
		Check valve type	Pressure plate system
		Backfire protection (type)	Diverter valve
	Exhaust Gas Recirculation System	Type (controlled flow, open orifice, other)	Controlled flow
		Valve type	Vacuum modulated shut-off & metering valve
		Valve location	Inlet manifold
		Control energy source	Carburetor vacuum
		Exhaust source	Manifold exhaust crossover
		Exhaust orifice type	None
		Orifice orifice size	One
		Point of exhaust injection (spacer, carburetor manifold, other)	Inlet manifold
Catalytic Converter System	Catalyst Type	Platinum - Palladium - Rhodium	
	Volume—L(in ³)	4.1 (250) (a)	
	Substrate type	Dual bed (b)	
	Container location	Beneath RF underbody	
Other	Carburetor Hot Air		Thermostatically controlled air cleaner regulates and mixes heated air with incoming cold air to reduce hydrocarbon emissions.

(a) Catalyst - Volume LD5 engine 4.261 (260)
 (b) Single bed for LD5 engine

MVMA Specifications Form
Passenger Car
METRIC (U.S. Customary)

Car Line MONTE CARLO-MALIBU CLASSIC-EL CAMINO
 Model Year 1982 Issued 8-81 Revised (*)

Engine Description/Carb.
 Engine Code

4.3 LITER V8 (262 CID) FUEL INJECTION DIESEL RPO LT6	5.7 LITER V8 (350 CID) FUEL INJECTION DIESEL RPO LE9
--	--

Vehicle Emission Control

	Type (air injection, engine modifications, other)		
	Air Injection Pump	Type	
Displacement—cm ³ (in ³)			
Drive ratio			
Drive type			
Relief valve (type)			
Air Injection System	Filter (describe)		
	Air distribution (head, manifold, etc.)		
	Point of entry		
	Injection tube id		
Exhaust Emission Control	Check valve type		
	Backfire protection (type)		
	Type (controlled flow, open orifice, other)	Variable orifice	
	Valve type	Spool	
	Valve location	Air crossover	
	Control energy source	Throttle position	
	Exhaust source	Intake manifold	
Exhaust cooler type	None		
Exhaust Circulation System	Orifice no. and size	None	
	Point of exhaust injection (spacer, carburetor manifold, other)	Air crossover	
Catalytic Converter System	Catalyst	Type	
		Volume—L(in ³)	
	Substrate type		
Other	Container location		

MVMA Specifications Form
Passenger Car
METRIC (U.S. Customary)

Car Line MONTE-CARLO - MALIBU CLASSIC - EL CAMINO
 Model Year 1982 Issued 8-81 Revised (*) _____

Engine Description/Carb.
 Engine Code

3.8 LITER V6 (229 CID) 2-BBL. CARBURETOR RPO LC3	3.8 LITER V6 (231 CID) 2-BBL. CARBURETOR RPO LD5
--	--

Vehicle Emission Control (continued)

		Type (ventilates to atmos. induction system, other)	Standard	Optional		
Crankcase Emission Control					Induction system	
	Control unit	Make and Model			A.C.	
		Location			Inl. man.	Valve rocker cover
		Energy source (manifold vacuum, carburetor, other)			Manifold vacuum	
		Control method (variable orifice, fixed orifice, other)			Variable orifice	
	Complete system	Discharges (to intake manifold, other)			Inlet manifold	
		Air inlet (breather cap, other)			Carburetor air cleaner	
		Flame arrestor (screen, other)			Screen	
	Evaporative Emission Control	Fuel tank	Thermal expansion volume - dm ³ (ft ³)			Approx. 10% of refill capacity
Relief pressure kPa (psi) and location						
Vacuum relief kPa (psi) and location						
Vapor-liquid separator type					Integral with fuel tank	
Vapor vented to (crankcase, canister, other)					Canister	
Carbu-retor		Vapor vented to (crankcase, canister, other)			Canister	
Vapor storage		Storage provision (crankcase, canister, other)			Canister	
		Volume - dm ³ (ft ³) or capacity (grams)			Approx. 50 grams storage capacity	
		Control valve type			Controlled by orifice, carburetor throttle body and throttle blade position	

MVMA Specifications Form
Passenger Car
METRIC (U.S. Customary)

Car Line MONTE-CARLO - MALIBU CLASSIC - EL CAMINO
 Model Year 1982 Issued 8-81 Revised (*) _____

Engine Description/Carb.
 Engine Code

4.4 LITER V8 (267 CID) 2-BBL. CARBURETOR RPO L39	5.0 LITER V8 (305 CID) 4-BBL. CARBURETOR RPO LG4
--	--

Vehicle Emission Control (continued)

		Standard	Optional	
Crankcase Emission Control	Type (ventilates to atmos. induction system, other)	Induction system		
	Control unit	Make and Model	A.C.	
		Location	Inl. man.	Valve rocker cover
		Energy source (manifold vacuum, carburetor, other)	Manifold vacuum	
		Control method (variable orifice, fixed orifice, other)	Variable orifice	
	Complete system	Discharges (to intake manifold, other)	Inlet manifold	
		Air inlet (breather cap, other)	Carburetor air cleaner	
		Flame arrestor (screen, other)	Screen	
	Evaporative Emission Control	Fuel tank	Thermal expansion volume—dm ³ (ft ³)	Approx. 10% of refill capacity
Relief pressure kPa (psi) and location				
Vacuum relief kPa (psi) and location				
Vapor-liquid separator type			Integral with fuel tank	
Vapor vented to (crankcase, canister, other)			Canister	
Carbu- retor		Vapor vented to (crankcase, canister, other)	Canister	
		Vapor storage	Storage provision (crankcase, canister, other)	Canister
Volume—dm ³ (ft ³) or capacity (grams)			Approx. 50 grams storage capacity	
Control valve type			Controlled by orifice, carburetor throttle body and throttle blade position	

MVMA Specifications Form
Passenger Car
METRIC (U.S. Customary)

Car Line MONTE-CARLO - MALIBU CLASSIC - EL CAMINO
 Model Year 1982 Issued 8-81 Revised (#) _____

Engine Description/Carb.
 Engine Code

4.3 LITER V6 (262 CID) FUEL INJECTION DIESEL RPO LT6	5.7 LITER V8 (350 CID) FUEL INJECTION DIESEL RPO LF9
--	--

Vehicle Emission Control (continued)

Crankcase Emission Control	Type (ventilates to atmos., induction system, other)	Standard Optional	<u>Positive crankcase ventilation (induction)</u> -	
	Control unit	Make and Model	<u>AC/ crankcase depression regulator valve</u>	
		Location	<u>RH valve cover LH rear of intake</u>	
		Energy source (manifold vacuum, carburetor, other)	<u>Manifold Vacuum</u>	
		Control method (variable orifice, fixed orifice, other)	<u>Variable Orifice</u>	
	Complete system	Discharges (to intake manifold, other)	<u>Intake Manifold</u>	
		Air inlet (breather cap, other)	<u>Breather Cap</u>	
		Flame arrestor (screen, other)	<u>-</u>	
	Evaporative Emission Control	Fuel tank	Thermal expansion volume—dm ³ (ft ³)	
			Relief pressure kPa (psi) and location	
Vacuum relief kPa (psi) and location				
Vapor-liquid separator type				
Vapor vented to (crankcase, canister, other)				
Carbu- retor	Vapor vented to (crankcase, canister, other)			
	Vapor storage	Storage provision (crankcase, canister, other)		
Volume—dm ³ (ft ³) or capacity (grams)				
Control valve type				

MVMA Specifications Form
Passenger Car
METRIC (U.S. Customary)

Car Line MONTE CARLO-MALIBU CLASSIC-EL CAMINO
 Model Year 1982 Issued 8-81 Revised (*) 10-81

Engine Description/Carb.
 Engine Code

3.8L V6 (229 CID) 2-BBL. CARBURETOR RPO LC3	3.8L V6 (231 CID) 2-BBL. CARBURETOR RPO LD5	4.3L V6 (262 CID) FUEL INJ DIESEL RPO LT6
---	---	---

Electrical - Supply System

Battery	Make and model	Delco "Freedom II"			
	Voltage rfg.-V-& total plates	12 Volt			
	SAE designation no. and/or capacity	80 minute reserve capacity	75 minute reserve capacity	115 minute reserve capacity (2 required)	
	Location	Engine compartment, right front			
Generator or alternator	Make	Delco Remy			
	Model	1103161	1100110	1100165	
	Type and rating	37	42	63	
	Output at engine idle (neutral) A				
	Ratio-gen. to crs rev.	2.73:1			
Regulator	Make	Delco Remy			
	Model	Integral with alternator			
	Type	Micro circuit unit; integral with distributor			
	Regulated	Voltage	--		
		Current A	--		
	Voltage test conditions	Temperature - °C (°F)	--		
		Load A	--		
Other		Tested with alternator			

Electrical - Starting System

Starting motor	Make	Delco Remy			
	Model	1109524	1998552		
Motor drive	Engagement type	Positive shift solenoid			
	Pinion engages from (front, rear)	Rear	Front	Front	
	Number of teeth	Pinion	9	10	
		Flywheel	Manual	153	Not available
			Auto	153	160

MVMA Specifications Form
Passenger Car
METRIC (U.S. Customary)

Car Line MONTE CARLO-MALIBU CLASSIC-EL CAMINO
 Model Year 1982 Issued 8-81 Revised (*) 10-81

Engine Description/Carb.
 Engine Code

3.8L V6 (229 CID) 2-BBL. CARBURETOR RPO LC3	3.8L V6 (231 CID) 2-BBL. CARBURETOR RPO LD5	4.3L V6 (262 CID) FUEL INJ. DIESEL RPO LT6
---	---	--

Electrical — Ignition System

Type	Conventional—std., opt. n.a.	--	
	Transistorized—std., opt. n.a.	--	
	Other (specify)	High Energy Ignition (HEI)	
Coil	Make	Delco Remy	
	Model	Integral with distributor	
	Current	Engine stopped — A	--
		Engine idling — A	--
Spark plug	Make	AC	
	Model	R45TS	
	Thread (mm)	14	
	Tightening torque—N-m (lb. ft.)	20 (15)	
	Gap	1.143 (.045)	

Electrical — Suppression

Locations & type Internal alternator capacitor, non-metallic high-tension cables, resistor spark plugs, ignition coil by-pass capacitor, internal AC blower motor by-pass capacitor & A/C compression diode, with radio provisions; hood grounding clip, engine to dash panel ground strap, fuse block capacitor and on "heater only" blower motors and coax capacitor.

Electrical — Instruments and Equipment

Speed-ometer	Type	Circular dial with pointer
	Trip odometer (std., opt. n.a.)	Not available
EGR maintenance indicator		Not available
Charge indicator	Type	Tell-tale
	Warning device	Not available
Temperature indicator	Type	Tell-tale
	Warning device	Not available
Oil pressure indicator	Type	Tell-tale
	Warning device	Not available
Fuel indicator	Type	Electric gauge
	Warning device	Not available
Windshield wiper	Type — standard	Electric two-speed
	Type — optional	Intermittent windshield wiper system
	Blade length	457 (18.0)
	Swept area — cm ² (in. ²)	Monte Carlo & El Camino 6000 (930.3) *
Windshield washer	Type — standard	Push Button
	Type — optional	Not available
	Fluid level indicator	Not available
Horn	Type	Vibrator
	Number used	Dual
Other		Restraint system warning light and buzzer Parking brake and brake failure warning light Optional pkg, includes tachometer, voltmeter, oil pressure and coolant temperature gauges.

* Sedan & Wgn 5931 (919.5)

MVMA Specifications Form
Passenger Car
METRIC (U.S. Customary)

Car Line MONTE CARLO-MALIBU CLASSIC-EL CAMINO
 Model Year 1982 Issued 8-81 Revised (*) 10-81

Engine Description/Carb.
 Engine Code

4.4L V8 (267 CID) 2-BBL. CARBURETOR RPO L39	5.0L (305 CID) 4-BBL. CARBURETOR RPO L64	5.7L V8 (350 CID) FUEL INJ. DIESEL RPO LE9
---	--	--

Electrical -- Supply System

Battery	Make and model	Delco "Freedom II"		
	Voltage reg. -V- & total plates	12 Volt		
	SAE designation no. and/or capacity	75 minute reserve capacity	115 minutes reserve capacity (2 required)	
	Location	Engine compartment, right front		
Generator or alternator	Make	Delco Remy		
	Model	1103162	1103162	1100111
	Type and rating	37	37	63
	Output at engine idle (neutral) A			
	Ratio-gen. to crs rev.	2.73:1		
Regulator	Make	Delco Remy		
	Model	Integral with alternator		
	Type	Micro circuit unit; integral with distributor		
	Regulated	Voltage	--	
		Current A	--	
	Voltage test conditions	Temperature - (C/F)	--	
		Load A	--	
Other		Tested with alternator		

Electrical -- Starting System

Starting motor	Make	Delco Remy				
	Model	1109064	1998552			
Motor drive	Engagement type	Positive shift solenoid				
	Pinion engages from (front, rear)	Rear	Front			
	Number of teeth	Pinion	9	10		
		Flywheel	Manual	168	Not available	
			Auto	168	135	

MVMA Specifications Form
Passenger Car
METRIC (U.S. Customary)

Car Line MONTE CARLO-MALIBU CLASSIC-EL CAMINO
 Model Year 1982 Issued 8-81 Revised (*) 10-81

Engine Description/Carb.
 Engine Code

4.4L V8 (267 CID) 2-BBL. CARBURETOR RPO L39	5.0L V8 (305 CID) 4-BBL. CARBURETOR RPO L64	5.7L V8 (350 CID) FUEL INJ. DIESEL RPO LF9
---	---	--

Electrical - Ignition System

Type	Conventional—std., opt., n.a.		--
	Transistorized—std., opt., n.a.		--
	Other (specify)		High Energy Ignition (HEI)
Coil	Make		Delco Remy
	Model		Integral with distributor
	Current	Engine stopped - A	--
		Engine idling - A	--
Spark plug	Make		AC
	Model		R45TS
	Thread (mm)		14
	Tightening torque—N-m (lb. ft.)		20 (15)
	Gap		1.143 (.045)

Electrical - Suppression

Locations & type	Internal alternator capacitor, non-metallic high-tension cables, resistor spark plugs, ignition coil by-pass capacitor, internal AC blower motor by-pass capacitor & A/C compression diode, with radio provisions; hood grounding clip, engine to dash panel ground strap, fuse block capacitor and on "heater only" blower motors and coax capacitor.
------------------	--

Electrical - Instruments and Equipment

Speed-ometer	Type	Circular dial with pointer
	Trip odometer (std., opt., n.a.)	Not available
EGR maintenance indicator		Not available
Charge indicator	Type	Tell-Tale
	Warning device	Not available
Temperature indicator	Type	Tell-tale
	Warning device	Not available
Oil pressure indicator	Type	Tell-Tale
	Warning device	Not available
Fuel indicator	Type	Electric gauge
	Warning device	Not available
Wind-shield wiper	Type - standard	Electric two-speed
	Type - optional	Intermittent windshield wiper system
	Blade length	457 (18.0)
	Swept area - cm ² (in. ²)	Monte Carlo & El Camino 6000 (930.3)*
Wind-shield washer	Type - standard	Push Button
	Type - optional	Not available
	Fluid level indicator	Not available
Horn	Type	Vibrator
	Number used	Dual
Other	Restraint system warning light and buzzer Parking brake and brake failure warning light. optional pkg, includes tachometer, voltmeter, oil pressure and coolant temperature gauges.	

* Sedan & Wgn 5931 (919.5)

MVMA Specifications Form
Passenger Car
METRIC (U.S. Customary)

Car Line MONTE CARLO-MALIBU CLASSIC-EL CAMINO
 Model Year 1982 Issued 8-81 Revised (*) 10-81

Engine Description/Carb.
 Engine Code

3.8L V6 (229 CID) 2-BBL. CARBURETOR RPO LC3	3.8L V6 (231 CID) 2-BBL CARBURETOR RPO LD5	4.3L V6 (262 CID) FUEL INJ. DIESEL RPO LT6
---	--	--

Drive Units - Clutch (Manual Transmission)

Make & type		
Type pressure plate springs		NOT
Total spring load - N (lb.)		APPLICABLE
No. of clutch driven discs		
Clutch facing	Material	
	Manufacturer	
	Part number	
	Rivets/plate	
	Rivet size	
	Outside & inside dia.	
	Total eff. area - cm ² (in. ²)	
	Thickness	
Engagement cushion method		
Release bearing	Type & method of lubrication	
Torsional damping	Method: springs, friction material	

Drive Units - Transmissions

Manual 3-speed (std., opt., n.a.)	NOT available
Manual 4-speed (std., opt., n.a.)	NOT available
Manual 5-speed (std., opt., n.a.)	NOT available
Manual overdrive (std., opt., n.a.)	NOT available
Automatic (std., opt., n.a.)	Standard
Automatic overdrive (std., opt., n.a.)	NOT available

Drive Units - Manual Transmission

Number of forward speeds			
Transmission ratios	In first	NOT AVAILABLE	
	In second	AVAILABLE	
	In third		
	In fourth		
	In fifth		
	In overdrive		
	In reverse		
Synchronous meshing, specify gears			
Shift lever location			
Lubricant	Capacity - L (pt.)		
	Type recommended		
	SAE viscosity number	Summer	
		Winter	
Extreme cold			

MVMA Specifications Form
Passenger Car
METRIC (U.S. Customary)

Car Line MONTE CARLO-MALIBU CLASSIC-EL CAMINO
 Model Year 1982 Issued 8-81 Revised (9) 10-1981

Engine Description/Carb.
 Engine Code

4.4L V8 (267 CID) 2-BBL. CARBURETOR RPO L39	5.0L V8 (305 CID) 4-BBL. CARBURETOR RPO LG4	5.7L V8 (350 CID) FUEL INJ. DIESEL RPO LF9
---	---	--

Drive Units - Clutch (Manual Transmission)

Make & type	
Type pressure plate springs	NOT
Total spring load-N (lb.)	APPLICABLE
No. of clutch driven discs	
Clutch facing	Material
	Manufacturer
	Part number
	Rivets/plate
	Rivet size
	Outside & inside dia.
	Total eff. area-cm ² (in. ²)
	Thickness
Engagement method	
Release bearing	Type & method of lubrication
Torsional damping	Method: springs, friction material

Drive Units - Transmissions

Manual 3-speed (std., opt., n.a.)	Not available
Manual 4-speed (std., opt., n.a.)	Not available
Manual 5-speed (std., opt., n.a.)	Not available
Manual overdrive (std., opt., n.a.)	Not available
Automatic (std., opt., n.a.)	Standard
Automatic overdrive (std., opt., n.a.)	Not available

Drive Units - Manual Transmission

Number of forward speeds		
Transmission ratios	In first	NOT
	In second	AVAILABLE
	In third	
	In fourth	
	In fifth	
	In overdrive	
	In reverse	
Synchronous meshing, specify gears		
Shift lever location		
Lubricant	Capacity-L (qt)	
	Type recommended	
	SAE viscosity number	Summer
		Extreme cold

MVMA Specifications Form
Passenger Car
METRIC (U.S. Customary)

Car Line MONTE CARLO-MALIBU CLASSIC-EL CAMINO
 Model Year 1982 Issued 8-81 Revised (*)

Engine Description/Carb. Engine Code	3.8L V6 (229 CID)	3.8L V6 (231 CID)	4.3L V6 (262 CID)
	2-BBL. CARBURETOR RPO LC3	2-BBL. CARBURETOR RPO LD5	FUEL INJ. DIESEL RPO LT6

Drive Units – Automatic Transmission (See "Power Teams" for transmission usage)

Trade name		3-Speed Automatic	
Type (describe)		Torque converter with planetary gears '250c' '350c' '200c'	
Selector	Location	Standard-steering column	
	Ltr./No designation	P-R-N-D-2-1	
Gear ratios	R	1.93	2.07
	D	1.00	1.00
	L ₃	1.52	1.57
	L ₂	2.52	2.74
	L ₁	--	--
Max upshift speed—drive range—km/h (mph)		--	
Max kickdown speed—drive range—km/h (mph)		--	
Min overdrive speed—km/h (mph)		--	
Torque converter	Number of elements	3	
	Max. ratio at stall	2.0	2.2
	Type of cooling (air, liquid)	Liquid	
	Nominal diameter	298 (11.75)	
Lubricant	Capacity—refill—L (pt.)	2.8 (6.0)	
	Type recommended	Dexron II	
Special transmission features		Torque converter clutch, 3rd gear lock-up	

Drive Units – Axle or Front Wheel Drive Unit

Type (front, rear)		Rear		
Description		Semi-floating axle, overhung hypoid drive pinion and ring gear.		
Limited slip differential, type		Disc Clutch		
Drive pinion offset		38.1 (1.50)		
Drive pinion type		Hypoid gear		
No. of differential pinions		Two		
Pinion adjustment (shim, other)		Shim		
Pinion bearing adj. (shim, other)		Collapsible sleeve		
Driving wheel bearing type		Direct or single row cylindrical		
Lubricant	Capacity—L (pt.)	1.6 (3.5)		
	Type recommended	GL5 gear lubricant		
	SAE viscosity number	Summer	80W or 80W-90	
		Winter	80W or 80W-90	
		Extreme cold	80W or 80W-90	

Axle or Transaxle Ratio and Tooth Combinations (See "Power Teams" for axle ratio usage.)

Axle ratio or overall ratio		2.41	2.73
No. of teeth	Pinion	17	15
	Ring gear or gear	41	41
Ring gear O.D. —mm (in)		191 (7.5)	191 (7.5)
Transaxle	Transfer gear ratio	--	--
	Final drive ratio	--	--

MVMA Specifications Form
Passenger Car
METRIC (U.S. Customary)

Car Line MONTE CARLO-MALIBU CLASSIC-EL CAMINO
 Model Year 1982 Issued 8-81 Revised (*) _____

Engine Description/Carb.
 Engine Code

4.4L V8 (267 CID) 2-BBL. CARBURETOR RPO L39	5.0L V8 (305 CID) 4-BBL. CARBURETOR RPO LG4	5.7L V8 (350 CID) FUEL INJ. DIESEL RPO LF9
---	---	--

Drive Units - Automatic Transmission

Trade name		3-Speed Automatic
Type (describe)		Torque converter with planetary gears '250c' '350c'
Selector	Location	Standard-steering column
	Ltr/No designation	P-R-N-D-2-1
Gear ratios	R	1.93
	D	1.00
	L3	1.52
	L2	2.52
	L1	--
Max upshift speed-drive range-km/h (mph)		--
Max kickdown speed-drive range-km/h (mph)		--
Min overdrive speed-km/h (mph)		--
Torque converter	Number of elements	3
	Max ratio at stall	2.0
	Type of cooling (air, liquid)	Liquid
	Nominal diameter	298 (11.75)
Lubricant	Capacity-refill-L (pt.)	2.8 (6.0)
	Type recommended	Dexron II
Special transmission features		Torque converter clutch, 3rd gear lock-up

Drive Units - Axle or Front Wheel Drive Unit

Type (front/rear)		Rear	
Description		Semi-floating axle, overhung hypoid drive pinion and ring gear.	
Limited slip differential, type		Disc Clutch	
Drive pinion offset		38.1 (1.50)	
Drive pinion type		Hypoid gear	
No. of differential pinions		Two	
Pinion adjustment (shim, other)		Shim	
Pinion bearing adj. (shim, other)		Collapsible sleeve	
Driving wheel bearing type		Direct or single row cylindrical	
Lubricant	Capacity-L (pt.)		1.6 (3.5)
	Type recommended		GL5 gear lubricant
	SAE viscosity number	Summer	80W or 80W-90
		Winter	80W or 80W-90
		Extreme cold	80W or 80W-90

Axle or Transaxle Ratio and Tooth Combinations (See "Power Teams" for axle ratio usage.)

Axle ratio or overall ratio		2.29	2.41	2.56	2.73
No of teeth	Pinion	21	17	16	15
	Ring gear or gear	48	41	41	41
Ring gear O.D. -mm (in)		191 (7.50)	191 (7.5)	191 (7.5)	191 (7.5)
Transaxle	Transfer gear ratio	--	--	--	--
	Final drive ratio	--	--	--	--

MVMA Specifications Form
Passenger Car
METRIC (U.S. Customary)

Car Line MONTE CARLO-MALIBU CLASSIC-EL CAMINO
 Model Year 1982 Issued 8-81 Revised (*): _____

Engine Description/Comb.
 Engine Code

3.8 L V6 (229 CID) 2-BBL CARBURETOR RPO LC3	3.8 L V6 (231 CID) 2-BBL CARBURETOR RPO LD5	4.3 LV6 (262 CID) FUEL INJECTION DIESEL RPO LT6
---	---	---

Drive Units — Propeller Shaft — Conventional Drive

Type (straight tube, tube-in-tube, internal-external damper, etc.)		Straight tube	
Outer diam x length* x wall thickness	Manual 3-speed trans.	Not available	
	Manual 4-speed trans.	Not available	
	Manual 5-speed trans.	Not available	
	Disc drive	Not available	
	Automatic transmission	Monte Carlo, sedan & wagon 63.5x1331.5x1.65 (2.5x52.4x.065) El Camino 82.6x1560.1x1.65 (3.25x61.4x.065)	
Inter-mediate bearing	Type (plain, anti-friction)	None	
	Lubrication (fitting, prepack)	--	
Slip yoke	Type	Yoke	
	Number of teeth	27	
	Spline oil	--	
Universal joints	Shaft and yoke, no.	Front	Saginaw 44
		Rear	--
	Number used	Two	
	Type (ball and trunnion, cross)	Single Cardan	
	Rear attach (to-bolt, clamp, etc.)	Strap & Bolt	
	Steering	Type (plain, anti-friction)	Anti-friction
Lubric. (fitting, prepack)		Prepacked	
Drive taken through (torque tube or arms, springs)		Control arms	
Torque taken through (torque tube or arms, springs)		Control arms	

* Centerline to centerline of universal joints, or to centerline of rear attachment.

MVMA Specifications Form
Passenger Car
METRIC (U.S. Customary)

Car Line MONTE CARLO-MALIBU CLASSIC-EL CAMINO
 Model Year 1982 Issued 8-81 Revised (*) _____

Engine Description/Carb.
 Engine Code

4.4 L V8 (267 CID) 2-BBL CARBURETOR RPO L39	5.0 L V8 (305 CID) 4-BBL CARBURETOR RPO LG4	5.7 L V8 (350 CID) FUEL INJECTION DIESEL RPO LF9
---	---	--

Drive Units -- Propeller Shaft -- Conventional Drive

Type (straight tube, tube-in-tube, internal-external damper, etc.)		Straight tube	
Outer diam x length* x wall thickness	Manual 3-speed trans	Not available	
	Manual 4-speed trans.	Not available	
	Manual 5-speed trans	Not available	
	Overdrive	Not available	
	Automatic transmission	Monte Carlo, sedan & wagon 63.5x1331.5x1.65 (2.5x52.4x.065) El Camino-82.6x1560.1x1.65 (3.25x61.4x.065)	
Inter-mediate bearing	Type (plain anti-friction)	None	
	Lubrication (fitting prepack)	--	
Slip yoke	Type	Yoke	
	Number of teeth	27	
	Spline o.d.	--	
Universal joints	Make and mfg. no.	Front	Saginaw 44
		Rear	--
	Number used		Two
	Type (ball and trunion, cross)		Single cardan
	Rear attach (u-bolt, clamp, etc.)		Strap & Bolt
	Bearing	Type (plain, anti-friction)	Anti-friction
Lubric. (fitting, prepack)		Prepacked	
Drive taken through (torque tube or arms, springs)		Control arms	
Torque taken through (torque tube or arms, springs)		Control arms	

* Centerline to centerline of universal joints or to centerline of rear attachment.

MVMA Specifications Form
Passenger Car
METRIC (U.S. Customary)

Car Line MONTE CARLO-MALIBU CLASSIC-EL CAMINO
 Model Year 1982 Issued 8-81 Revised (*) _____

Engine Description/Carb.
 Engine Code

MONTE CARLO COUPE	MALIBU CLASSIC SEDAN
--------------------------	-----------------------------

Drive Units - Tires And Wheels (Standard)

Tires	Size, load range, ply	P195/75R-14 (BW & WW) @		P185/75R-14 (BW & WW)	
	Type (bias, radial, etc.)	Steel belted radial		Glass belted radial	
	Inflation pressure (cold) for recommended max vehicle load	Front-kPa (psi)	240 (35)		
		Rear-kPa (psi)	240 (35)		
	Rev/mile—at 70 km/h (45 mph)	520 (817)		520 (837)	
Wheels	Type & material	Short spoke disc, steel			
	Rim (size & flange type)	14 x 6			
	Wheel offset	Zero			
	Attachment	Type (bolt or stud)	Star		
		Circle diameter	120.7 (4.75)		
	Number & size	5 hex nuts - 7/16-20			
Spare tire and wheel (same or other)		15 x 4, 2.5 mm (1.0 in) offset			
		limited slip differential			

Drive Units - Tires And Wheels (Optional)

Size, load range, ply	P205/70R14 (BW & WW) +	P195/75R-14 (WW)
Type (bias, radial, etc.)	Steel belted radial	Steel belted radial
Wheel type & material	Rally type (RPO ZJ7)	Rally type, steel
Rim (size, flange type, and offset)	14 x 6 - Zero	14 x 6 - Zero
Size, load range, ply		
Type (bias, radial, etc.)		
Wheel type & material	Cast aluminum	
Rim (size, flange type, and offset)	14 x 6.5, - 6.35 mm (-0.25 in)	
Size, load range, ply		*P205/70R14 (WW, WL)
Type (bias, radial, etc.)		Steel belted radial
Wheel type & material		
Rim (size, flange type, and offset)		
Size, load range, ply		
Type (bias, radial, etc.)		
Wheel type & material		
Rim (size, flange type, and offset)		
Spare tire and wheel (if configuration is different than road tire or wheel, describe optional spare tire and/or wheel)	Steel-with limited slip differential-16 x 4 12 mm (0.50 in) offset. Tire-without limited slip differential T125/70D-15; with limited slip differential - P145/80D-16.	

Brakes - Parking

Type of control	Foot pedal - application; 'T' handle - release	
Location of control	Under instrument panel, left of steering column	
Operates on	Rear service brakes	
If separate from service brakes	Type (internal or external)	--
	Drum diameter	--
	Lining size (length x width x thickness)	--

- @ - Not available with sport suspension, RPO F41.
- + - Requires sport suspension, RPO F41.
- * - Required with RPO F41 sport suspension.

MVMA Specifications Form

Passenger Car
METRIC (U.S. Customary)

Car Line MUNTE CARLO-MALIBU CLASSIC-EL CAMINO
 Model Year 1982 Issued 8-81 Revised (*) 10-81

Engine Description/Carb.
 Engine Code

MALIBU CLASSIC STATION WAGON	EL CAMINO SEDAN PICK-UP
---------------------------------	----------------------------

Drive Units—Tires And Wheels (Standard)

Tires	Size, load range, ply	P195/75R-14 (BW & WW)	P205/75R-14 (BW, WW, WL)	
	Type (bias, radial, etc.)	Glass belted radial	Steel belted radial	
	Inflation pressure (cold for recommended max. vehicle load)	Front-kPa (psi)	205 (30)	
		Rear-kPa (psi)	240 (35)	
Revolutions at 70 km/h (45 mph)		508 (817)	495 (797)	
Wheels	Type & material	Short spoke disc, steel		
	Rim (size & flange type)	14 x 6		
	Wheel offset	Zero		
	Attachment	Type (bolt or stud)	Stud	
Circle diameter		120.7 (4.75)		
Number & size		5 hex nuts - 7/16 - 20		

Spare tire and wheel (same or other) 15 x 4 25 mm (1.0 in) offset exc. with limited slip differential - Tire T125/70D-15, Station wagon. (*)

Drive Units—Tires And Wheels (Optional) *El Camino, spare tire P205/75R-14x6 wheel. Offset-zero.

Size, load range, ply	P195/75R-14 (WW)	P205/75R-14 (BW, WW, WL)
Type (bias, radial, etc.)	Steel belted radial	Steel belted radial
Wheel type & material	Rally type steel	Rally type steel
Rim (size, flange type, and offset)	14 x 6 - zero	14 x 6 - zero
Size, load range, ply		
Type (bias, radial, etc.)		
Wheel type & material		
Rim (size, flange type, and offset)		
Size, load range, ply		
Type (bias, radial, etc.)		
Wheel type & material		
Rim (size, flange type, and offset)		
Size, load range, ply		
Type (bias, radial, etc.)		
Wheel type & material		
Rim (size, flange type, and offset)		
Spare tire and wheel (if configuration is different than road tire or wheel, describe optional spare tire and/or wheel)	Station wagon, wheel-with limited slip differential - 16x4, 12mm (0.50 in) offset. Tire-without limited slip differential T125/70D-15; with limited slip differential - P145/80D-16.	

Brakes - Parking

Type of control	Foot pedal - application, "T" handle - release	
Location of control	Under instrument panel, left of steering column	
Operates on	Rear service brake	
If separate from service brakes	Type (internal or external)	--
	Drum diameter	--
	Shoe size (length x width x thickness)	--

MVMA Specifications Form
Passenger Car
METRIC (U.S. Customary)

Car Line MONTE CARLO-MALIBU CLASSIC-EL CAMINO
 Model Year 1982 Issued 8-81 Revised (*)

Body Type And/Or
 Engine Displacement

MONTE CARLO 2-DOOR COUPE	MALIBU 4-DOOR SEDAN	MALIBU STATION WAGON	EL CAMINO SEDAN PICK-UP
--------------------------------	---------------------------	----------------------------	-------------------------------

Brakes - Service

Brake type (std., opt., n.a.)	Drum	Front	Not available	
		Rear	Standard	
	Disc	Front	Standard	
		Rear	Not available	
Self-adjusting (std., opt., n.a.)			Standard	
Special valving	Type (proportion, delay, metering, other)		Metering & proportioning	
Power brake (std., opt., n.a.)			Standard	
Booster type (remote, integral, vac., hyd., etc)			Integral	
Anti-skid device type (std., opt., n.a.)			Not available	
Effective area—cm ² (in.2)*			615.5 (95.42)	
Gross lining area—cm ² (in.2)**			691.6 (107.22)	
Swept area—cm ² (in.2)***			1985.1 (307.7)	
Rotor	Outer working diameter	F	266.7 (10.5)	
		R	--	
	Inner working diameter	F	171.5 (6.75)	
		R	--	
	Thickness	F	26.2 (1.03)	
		R	--	
Material & type (vented/solid)	F	Cast iron, vented		
	R	--		
Drum	Diameter (nominal)	F	--	
		R	241 (9.5)	
	Type and material		Cast iron, finned	
Wheel cyl. inder bore	Front	63.5 (2.50)		
	Rear	19.1 (0.75)		
Master cylinder	Bore	24.0 x 31.8 (0.94 x 1.25)		
	Stroke	37.05 (1.46)		
Pedal arc ratio		3.5:1		
Line pressure at 445 N (100 lb) pedal load—kPa (psi)			--	
Lining clearance per shoe	Front	Self adjusting		
	Rear	Self adjusting		
Brake lining	Front wheel	Bonded or riveted, rivets/seg.	Riveted 8	
		Rivet size	5.33 x 7.92 (.210 x .312)	
		Manufacturer	Delco moraine	
		Lining code	--	
		Material	Molded asbestos	
		****	Primary or out-board	125 x 48.4 x 11.04 (4.92 x 1.91 x .435)
		Size	Secondary or in-board	125 x 48.4 x 11.04 (4.92 x 1.91 x .435)
	Shoe thickness (no lining)		Inboard-15.84 (.620); Outboard-13.97 (.550)	
	Rear wheel	Bonded or riveted, rivets/seg.	Riveted - 10 primary, 12 secondary	
		Manufacturer	Delco Moraine	
		Lining code	--	
		Material	Molded asbestos	
		****	Primary or out-board	192.5 x 50.8 x 4.98 (7.58 x 2.0 x 0.196)
		Size	Secondary or in-board	249.6 x 50.8 x 6.75 (9.83 x 2.0 x 0.266)
Shoe thickness (no lining)		9.7 (0.380)		

* Excludes rivet holes, grooves, chamfers, etc

** Includes rivet holes, grooves, chamfers, etc

*** Total swept area for four brakes (Drum brake: Widest lining contact width for each brake x its contact circumference) (Disc brake: Square of Outer Work Dia minus Square of Inner Working Dia, multiplied by Pi/2 for each brake.)

**** Size for drum brakes includes length x thickness

MVMA Specifications Form
Passenger Car
METRIC (U.S. Customary)

Car Line MONTE CARLO-MALIBU CLASSIC-EL CAMINO
 Model Year 1982 Issued 8-81 Revised (*) _____

COUPE & SEDAN W/V-6 ENGINE	WAGON & PICKUP W/V-6 ENGINE	COUPE & SEDAN W/V-8 ENGINE	WAGON & PICKUP W/V-8 ENGINE
-------------------------------	--------------------------------	-------------------------------	--------------------------------

Steering

Manual (std., opt., n.a.)		Not available				
Power (std., opt., n.a.)		Standard				
Adjustable steering wheel (lift, swing, other)	Type and description	Tilt-universally jointed steering shaft at base of steering wheel - 6 positions				
	(Std., opt., n.a.)	Optional				
Wheel diameter	Manual	Not available				
	Power	387 (15.25)				
Turning diameter m (ft.)	Outside front	Wall to wall (l. & r.)	12.2 (40.0)	13.0 (42.6)		
		Curb to curb (l. & r.)	11.3 (37.1)	12.2 (40.0)		
	Inside rear	Wall to wall (l. & r.)	--	--		
		Curb to curb (l. & r.)	--	--		
Manual	Gear	Type	NOT			
		Make	--			
		Ratios	Gear	AVAILABLE		
		Overall	--			
	No. wheel turns (stop to stop)	--				
Power	Type (coaxial, linkage, etc.)		Integral gear with power piston & vane type pump			
	Make		Saginaw steering gear			
	Gear	Type	Semi-reversible recirculating ball nut			
		Ratios	Gear	75:1	15:1	16/13:1
			Overall	76.5:1	17.5:1	17.6:1
	Pump driven by		"V" Belt			
No. wheel turns (stop to stop)	3.3	3.2				
Linkage	Type		Parallelogram			
	Location (front or rear of wheels, other)		Front			
	Drag links (trans. or longit.)		None			
	Tie rods (one or two)		Two			
Steering axis	Inclination at camber (deg.)		7.86			
	Bearings (type)	Upper	Ball stud			
		Lower	Ball stud			
		Thrust	None			
Steering spindle & joint type		Forging with pad for mounting brake cylinder spherical				
Wheel spindle	Diameter	Inner bearing	31.7 (1.25)			
		Outer bearing	21.0471-21.4274 (01.83-0.84)			
	Thread size		3/4-20 UNEF-3A (modified)			
	Bearing type		Tapered roller			
Wheel align at curb mass (wt)	Service checking	Caster (deg.)	+2° to +4°			
		Camber (deg.)	-0.3° to +1.3°			
		Toe-in (outside track-mm (in.))	7.587 to 6.350 (1/16 to 1/4)			
	Service reset	Caster	+3° + 0.5°			
		Camber	+0.5 + 0.5°			
		Toe-in	+3.175 + 1.587 (+1/8 + 1/16)			
	Periodic MV inspection	Caster	+1° to +5			
		Camber	-1.0° to +2.0°			
		Toe-in	+3.175 to + 1.587 (+1/8 + 1/16)			

MVMA Specifications Form
Passenger Car
METRIC (U.S. Customary)

Car Line MONTE CARLO-MALIBU CLASSIC-EL CAMINO
 Model Year 1982 Issued 8-81 Revised (*)

Body Type and/Or
 Engine Displacement

MONTE CARLO-MALIBU 2 DOOR COUPE	-4 DOOR -SEDAN	MALIBU STATION WAGON	EL CAMINO SEDAN PICK-UP
---------------------------------------	-------------------	----------------------------	-------------------------------

Suspension - General

Car leveling	Std./opt./n.a.	N.A.	Standard (Rear only)
	Type (air, hyd., etc.)	--	Air
	Manual/auto. controlled	--	Manual
Provision for brake dip control		Front suspension geometry	
Provision for acc. squat control		Rear suspension geometry	
Special provisions for car jacking		Side lift frame body bolt access holes on each side of frame at #2 & #4 body mounting - access holes	
Shock absorber front & rear	Type	Direct double acting, hydraulic	
	Make	Delco	
	Piston dia	25 (1.0)	
Other special features		--	

Suspension - Front

Type and description		Independent SLA		
Travel	Full jounce	90 (3.54)		
	Full rebound	92 (3.62)		
Spring	Type (coil, leaf, other)	Coil		
	Material	Steel alloy		
	Size (coil design height & i.d., bar length x dia.)	260x102.9x2953 x15.6	260x102.9x2548 x15.6	260x102.9x2733 x16.0
	Spring rate - N/mm (lb./in.)	52.5 (300)	64 (365)	
	Rate at wheel - N/mm (lb./in.)	15.6 (89)	18.6 (106)	
Stabilizer	Type (link, linkless, frameless)	Link		
	Material & bar diameter	Steel-25 (0.98) RPO F41-32 (1.26)	V6-27 (1.06) V8-28 (1.10)	Less RPO F41-27 (1.06) With RPO F41-28 (1.10)

Suspension - Rear

Type and description		Salisbury, 4-Link		
Drive and torque taken through		Control arms		
Travel	Full jounce	107 (4.21)		
	Full rebound	113 (4.45)		
Spring	Type (coil, leaf, other)	Coil		
	Material	Steel alloy		
	Size (length x width, coil design height & i.d., bar length & dia.)	254x139.7x2428 x12.8	254x139.7x2535 x14.5	254x139.7x2398 x13.5
	Spring rate - N/mm (lb./in.)	17.5 (100)	24.5 (140)	21.9 (125)
	Rate at wheel - N/mm (lb./in.)	17.9 (102)	23.4 (133.6)	21.3 (121)
Mounting insulation type		--		
if leaf	No. of leaves	--		
	Shackle (comp. or tens.)	--		
Stabilizer	Type (link, linkless, frameless)	Link-included W/RPO F41 sport suspension (a)		
	Material & bar diameter	--		
Track bar type		--		

(a) Not available with station wagon, sedan, El Camino P185 or P195-75 tires.

MVMA Specifications Form
Passenger Car
METRIC (U.S. Customary)

Car Line MONTE CARLO-MALIBU CLASSIC-EL CAMINO
 Model Year 1982 Issued 8-81 Revised (*) _____

Body Type	MONTE CARLO	MALIBU	MALIBU	EL CAMINO
	2-DOOR COUPE	4-DOOR SEDAN	STATION WAGON	SEDAN PICK-UP

Body - Miscellaneous Information

Type of finish (lacquer, enamel, other)	Acrylic lacquer	
Hood hinge location (front, rear)	Rear	
Hood counterbalance (type)	Flat plate coil spring, hold open linkage	
Hood release control (internal, external)	Internal	
Vehicle ident. no. location	Top left of instrument panel pad	
	--	
Vent window control method (crank, friction pivot, power)	Front	None
	Rear	Pivot type for sedans and wagons - power optional
Seat cushion type	Front	Formed full foam pad
	Rear	Formed full foam pad
	3rd seat	--
Seat back type	Front	Formed full foam pad
	Rear	Formed full foam pad
	3rd seat	--
Method of holding luggage compartment lid open	Boxed hinges with torsion rod	
Position of spare tire storage	Sedan & coupe - semi-vertical right rear trunk area	
	Station wagons - horizontal, under rear load floor	
	El Camino - horizontal, behind passenger seat.	

Passive Restraint System

Inflatable restraint system	Standard/optional	Not available
	Type of charging system	--
	Location (slg wht instru panel other)	--
Passive seat belts	Standard/optional	Not available
	Power manual	--
	2 or 3 point	--
	Knee bar lap belt	--

Frame

Type and description (separate frame unitized frame, partially-unitized frame)	Full frame, perimeter type
--	----------------------------

MVMA Specifications Form
Passenger Car
METRIC (U.S. Customary)

Car Line MONTE CARLO-MALIBU CLASSIC-EL CAMINO
 Model Year 1982 Issued 8-81 Revised (*)

Body Type	2-DOOR COUPE	4-DOOR SEDAN	STATION WAGON	SEDAN PICK-UP
-----------	----------------------------	-----------------	------------------	------------------

Convenience Equipment

Power windows	Side windows	Optional
	Vent windows	Rear vent windows for sedan and wagon - optional
	Backlight or tailgate	Optional
Power seats (specify type as well as availability)	Optional - 6-way power bench seat 6-way 55/45 power bench seat, power drivers seat only	
Reclining front seat back (r-l or both)	Not available	
Radio (specify type as well as availability)	Optional-AM-push-button, AM/FM push-button, AM/FM Stereo AM/FM stereo w/8-track tape, AM/FM stereo w/cassette tape (a)	
Rear seat speaker	Optional, not available with El Camino	
Power antenna	Optional	
Clock	Standard Monte Carlo - optional other models	
Air conditioner (specify type)	Optional - "Four Season" manual control	
Speed warning device	Not available	
Speed control device	Optional with automatic transmission	
Ignition lock lamp	Not available	
Dome lamp	Standard	
Glove compartment lamp	Standard	
Luggage compartment lamp	Optional	
Underhood lamp	Optional	
Courtesy lamp	Standard	
Map lamp	Not available	
Cornering lamp	Not available	
Rear window defroster electrically heated	Optional - not available with El Camino	
Rear window defogger		
Theft protection—type	Lock mounted on steering column; locks steering wheel, transmission shift levers and ignition.	
Ash tray lamp	Standard	

(a) - Stereo equipment includes 2 front and 2 rear speakers.

MVMA Specifications Form
Passenger Car
METRIC (U.S. Customary)

Car Line MONTE CARLO-MALIBU CLASSIC-EL CAMINO
 Model Year 1982 Issued 8-81 Revised (*)

Equipment	Optional Equipment Differential Mass (weight)*			Remarks
	MASS, kg (weight, lb)			
	Front	Rear	Total	
Air Conditioning	32.2	2.4	34.6	With LC3 V6 Engine
4-Season	(+71.0)	(+5.3)	(+76.3)	
	22.0	1.6	23.6	With LD5 V6 Engine
	(+48.5)	(+3.5)	(+52.0)	
	26.0	2.0	28.0	With LT6 V6 Diesel Engine
	(+57.3)	(+4.4)	(61.7)	
	26.4	2.0	28.4	With L39 V8 Engine
	(+58.2)	(+4.4)	(+62.6)	
	26.0	2.0	28.0	With LG4 V8 Engine
	(+57.3)	(+4.4)	(+61.7)	
	26.0	2.0	28.0	With LF9 V8 Diesel Engine
	(+57.3)	(+4.4)	(+61.7)	
Electric Door Locks	1.2	0.8	2.0	With 2-Door Models
	(+ 2.6)	(+1.8)	(+ 4.4)	
	1.4	1.4	2.8	With 4-Door Models
	(+ 3.1)	(+3.1)	(+ 6.2)	
Power Tailgate Release	0	0.8	0.8	Station Wagon
	0	(+1.8)	(+ 1.8)	
Power Windows	1.2	1.2	2.4	2-Door Models
	(+ 2.6)	(+2.6)	(+ 5.2)	
	1.8	3.0	4.8	4-Door Station Wagons
	(+ 4.0)	(+6.6)	(+10.6)	
	2.6	3.2	5.8	4-Door Models includes
	(+ 5.7)	(+7.1)	(+12.8)	rear door vent windows
Seat 45/45 Passenger	2.6	2.8	5.4	Monte Carlo only
Front	(+ 5.7)	(+6.2)	(+11.9)	
Power Trunk Opener	0	2.0	2.0	Monte Carlo only
	(0)	(+4.4)	(+ 4.4)	
Cargo Tie-Down	0	0.6	0.6	El Camino
	(0)	(+1.3)	(+ 1.3)	
Heavy Duty Cooling	0.6	0	0.6	With LC3 Engine
	(+ 1.3)	(0)	(+ 1.3)	
	0.8	0	0.8	With LD5
	(+ 1.8)	(0)	(+ 1.8)	
	3.2	0	3.2	With LG4, L39, LT6, LF9
	(+ 7.1)	(0)	(+ 7.1)	

* Also see Engine - General Section for dressed engine mass (weight)

MVMA Specifications Form
Passenger Car
METRIC (U.S. Customary)

Car Line MONTE CARLO-MALIBU CLASSIC-EL CAMINO
 Model Year 1982 Issued 8-81 Revised (*)

Optional Equipment Differential Mass (weight)*

Equipment	MASS, kg (weight lb)			Remarks
	Front	Rear	Total	
Floor Mats - Front	1.6	0.6	2.2	El Camino
Only Color-Keyed	(+ 3.5)	(+1.3)	(+ 4.8)	
Floor Mats - Front & Rear Color-Keyed	+2.0	1.4	3.4	All except El Camino
	(+4.4)	(+3.1)	(+ 7.5)	
Deluxe Load Floor Carpet	-1.0	2.8	1.8	Station Wagon
	(- 2.2)	(+6.2)	(+ 4.0)	
Deluxe Luggage Compartment Trim	0.6	0.6	1.2	Monte Carlo
	(+1.3)	(+1.3)	(+ 2.6)	
Removable Glass Roof Panels	7.0	9.8	16.8	Monte Carlo
	(+15.4)	(+21.6)	(+37.0)	
Padded Opera - Vinyl Roof Cover	0.6	2.8	3.4	Monte Carlo
	(+1.3)	(+6.2)	(+ 7.5)	
Vinyl Roof Cover - Full	1.0	1.2	2.2	Monte Carlo & Malibu Sedan
	(+2.2)	(+2.6)	(+ 4.8)	
Mirror O/S Rear View	0.8	0.4	1.2	All
	(+1.8)	(+0.9)	(+ 2.7)	
Cargo Tonneau Cover	0	4.2	4.2	El Camino
	(0)	(+9.3)	(+ 9.3)	
Heavy Duty Front & Rear Suspension	2.0	0.2	2.2	Monte Carlo & Malibu Sedan
	(+4.4)	(+0.4)	(+ 4.8)	
Sport Suspension	3.0	8.0	11.0	Monte Carlo & El Camino
	(+6.6)	(+17.6)	(+24.2)	
Automatic Speed Control	2.4	0	2.4	All
	(+ 5.3)	(0)	(+ 5.3)	
Comfortilt Steering Wheel	1.2	0	1.2	All
	(+ 2.6)	(0)	(+ 2.6)	
Aluminum Wheels	- 1.8	-1.8	- 3.6	Monte Carlo
	(- 4.0)	(-4.0)	(- 8.0)	
Wire Wheel Covers	3.2	3.2	6.4	All
	(+ 7.1)	(+7.1)	(+14.2)	
Sport Wheel Covers	0.6	0.6	1.2	All except Monte Carlo
	(+ 1.3)	(+1.3)	(+ 2.6)	

* Also see Engine - General Section for dressed engine mass (weight)

MVMA Specifications Form
Passenger Car
METRIC (U.S. Customary)

Car Line MONTE CARLO MALIBU CLASSIC-EL CAMINO
 Model Year 1982 Issued 8-81 Revised (*)

Equipment	Optional Equipment Differential Mass (weight)*			Remarks
	MASS. kg (weight. lb)			
	Front	Rear	Total	
Battery-Heavy Duty	6.0 (+13.2)	-0.8 (-1.8)	5.2 (+11.4)	All
Gauge Package with Trip Odometer	0.4 (+ 0.9)	0 (0)	0.4 (+ 0.9)	All
Radio AM Push-Button	2.2 (+ 4.8)	0.2 (+0.4)	2.4 (+ 5.2)	All
Radio AM/FM Push-Button	2.6 (+ 5.7)	0.4 (+0.9)	3.0 (+ 6.6)	All
Radio AM/FM Stereo	3.2 (+ 7.1)	0.8 (+1.8)	4.0 (+ 8.8)	All
Radio AM/FM Stereo W/8-Track Tape Player	5.0 (+11.0)	0.8 (+1.8)	5.8 (+12.8)	All
Radio AM/FM Stereo W/Cassette Tape Player	4.6 (+10.1)	1.6 (+3.5)	6.2 (+13.6)	All
Rear Seat Speaker Requires U63 or U69	0 (0)	1.0 (+2.2)	1.0 (+ 2.2)	All except El Camino
Rear Seat Speaker - Dual	0 (0)	2.0 (+4.4)	2.0 (+ 4.4)	All except El Camino
Bumper Rub Strips	0.8 (+ 1.8)	0.8 (+1.8)	1.6 (+ 3.6)	All except Monte Carlo
Bumper Guards Front & Rear	1.6 (+ 3.5)	1.6 (+3.5)	3.2 (+ 7.1)	All except Monte Carlo
Roof Carrier	1.4 (+ 3.1)	5.2 (+11.5)	6.6 (+14.6)	Station Wagon
Rally Wheels	2.8 (+ 6.2)	2.8 (+6.2)	5.6 (+12.4)	All except El Camino
	0.8 (+ 1.8)	0.8 (+1.8)	1.6 (+ 3.6)	El Camino

* Also see Engine - General Section for dressed engine mass (weight)

MVMA Specifications Form
Passenger Car
METRIC (U.S. Customary)

Car Line MONTE CARLO-MALIBU CLASSIC-EL CAMINO
 Model Year 1982 Issued 8-81 Revised (*) _____

Equipment	Optional Equipment Differential Mass (weight)*			Remarks
	MASS kg (weight, lb)			
	Front	Rear	Total	
3.8 Liter-V6 (231 CID)	3.0	0.6	3.6	Monte Carlo
RPO - LD5	(+ 6.6)	(+1.3)	(+ 7.9)	
	3.0	0.4	3.4	4-Door Sedan
	(+ 6.6)	(+0.9)	(+ 7.5)	
	2.6	0.4	3.0	Station Wagon
	(+ 5.7)	(+0.9)	(+ 6.6)	
	3.4	0.6	4.0	El Camino
	(+ 7.5)	(+1.3)	(+ 8.8)	
4.3 Liter V6 (262 CID)	30.0	5.6	35.6	Monte Carlo & 4-Door Sedan
RPO - LT6, Diesel	(+66.1)	(+12.3)	(+78.4)	
4.4 Liter V8 (267 CID)	51.0	7.6	58.6	Monte Carlo
RPO - L39	(+112.4)	(+16.7)	(+129.1)	
	51.6	7.8	59.4	4-Door Sedan
	(+113.8)	(+17.2)	(+131.0)	
	55.4	8.2	63.6	Station Wagon
	(+122.1)	(+18.1)	(+140.2)	
	54.0	8.2	62.2	El Camino
	(+119.0)	(+18.1)	(+137.1)	
5.0 Liter V8 (305 CID)	42.6	6.4	49.0	Monte Carlo, California only.
RPO - LG4	(+93.9)	(+14.1)	(+108.0)	
	50.2	7.4	57.6	Station Wagon
	(+110.7)	(+16.3)	(+127.0)	
	47.2	7.0	54.2	El Camino
	(+104.1)	(+15.4)	(+119.5)	
5.7 Liter V8 (350 CID)	135.2	20.2	155.4	Monte Carlo & 4-Door Sedan
RPO - LF9, Diesel	(+298.1)	(+44.5)	(+342.6)	
	141.2	21.0	162.2	Station Wagon
	(+311.3)	(+46.3)	(+357.6)	

* Also see Engine - General Section for dressed engine mass (weight)

MVMA Specifications Form

Passenger Car METRIC (U.S. Customary) Car and Body Dimensions

Car Line MONTE CARLO-MALIBU CLASSIC-EL CAMINO
 Model Year 1982 Issued 8-81 Revised (*) 10-81

All dimensions to ground are for comparison purposes only. Dimensions are to be shown for all base body models of each car line.
 SAE Ref. No. refers to the definition published in SAE Recommended Practice.
 J1100a "Motor Vehicle Dimensions," unless otherwise specified.

Body Type

SAE Ref. No.	MONTE CARLO	MALIBU	MALIBU	EL CAMINO
	2-DOOR	4-DOOR	STATION WAGON	SEDAN
	COUPE	SEDAN		PICK-UP

Width

Tread — Front	W101	1486 (58.5)			
Tread — Rear	W102	1467 (57.8)			
Vehicle width	W103	1824 (71.8)	1837 (72.3)	1826 (71.4)	
Body width at Sg RP — front	W117	1784 (70.2)	1774 (69.8)	1774 (69.8)	1776 (69.9)
Vehicle width — front doors open	W120	3984 (157.0)	3376 (132.4)		4002 (157.6)
Vehicle width — rear doors open	W121	--	3225 (127.0)		

Length

Wheelbase	L101	2745 (108.1)			2974 (117.1)
Vehicle length	L103	5090 (200.4)	4895 (192.7)	4911 (193.3)	5121 (201.6)
Overhang — front	L104	1077 (42.4)	915 (36.0)		
Overhang — rear	L105	1268 (49.9)	1235 (48.6)	1251 (49.3)	1232 (48.5)
Upper structure length	L123	2305 (90.7)	2396 (94.3)	3261 (128.4)	1500 (59.1)
Rear wheel C/L "X" coordinate	L127	2377 (93.6)			
Cowl point "X" coordinate	L125	158 (6.2)			

Height **

Passenger Distribution (frt./rear)	PD1,2,3				**
Trunk/Cargo load					**
Vehicle height	H101	1380 (54.3)	1414 (55.7)	1418 (55.8)	1408 (55.4)
Cowl point to ground	H114	974 (38.3)	983 (38.7)	986 (38.8)	-
Deck point to ground	H138				
Rocker panel front to ground	H112	222 (8.7)	228 (9.0)	234 (9.2)	
Bottom of door closed - front to grd.	H133				
Rocker panel rear to ground	H111	223 (8.8)	237 (9.3)	243 (9.6)	245 (9.6)
Bottom of door closed - rear to grd.	H135	--			--

Ground Clearance **

Front bumper to ground	H102	317 (12.5)	349 (13.7)	351 (13.8)	
Rear bumper to ground	H104	344 (13.6)	357 (14.0)	353 (13.9)	356 (14.0)
Bumper to ground — front at curb mass (wt.)	H103	339 (13.3)	370 (14.5)		
Bumper to ground — rear at curb mass (wt.)	H105	366 (14.4)	378 (14.9)	369 (14.5)	371 (14.6)
Angle of approach @ GVW	H106	19.2°	23.3°	23.5°	
Angle of departure @ GVW	H107	17.2°	16.5°	16.7°	17.5°
Ramp breakover angle @ GVW	H147	14.3°	15.4°	15.6°	14.5°
Rear axle differential to ground	H153	299 (11.8)	294 (11.6)	295 (11.6)	309 (12.2)
Min. running ground clearance	H156	135 (5.3)	153 (6.0)	158 (6.2)	160 (6.3)
Location of min. run. grd. clear.		Rear shock absorber bracket			

All linear dimensions are in millimeters (inches) and all mass (weight) specifications are in kilograms (pounds).

** All vehicle height and ground clearances made using EPA loaded vehicle weight, loading conditions.

EPA LOADED VEHICLE WEIGHT is the vehicle weight plus all coolant and fluids necessary for operation plus 100% of the fuel capacity, plus the weight of all options and accessories which weigh three pounds or more and which are sold on at least 33% of the car line, plus two occupants.

Passenger Car
METRIC (U.S. Customary)
Car and Body Dimensions

Model Year 1982 Issued 8-81 Revised (*) 10-81

Key Sheets for definitions

Body Type

	MONTE CARLO 2-DOOR COUPE	MALIBU 4-DOOR SEDAN	MALIBU STATION WAGON	EL CAMINO SEDAN PICK-UP
--	--------------------------------	---------------------------	----------------------------	-------------------------------

Front Compartment

Sg RP front, "X" coordinate	1088 (42.8)			
Effective head room	956 (37.6)	978 (38.5)	985 (38.8)	956 (37.6)
Effective T Point head room	961 (37.8)	985 (38.8)	990 (39.0)	961 (37.8)
Max. eff. leg room — accelerator	1086 (42.8)			
Sg RP — front to heel	228 (9.0)			
Design H-point front travel	172 (6.8)			
Shoulder room	1430 (56.3)	1440 (56.7)		
Hip room	1313 (51.7)	1326 (52.2)		1313 (51.7)
** Upper body opening to ground				
Steering Wheel Angle	19.5°			
Back Angle	26.5°			

Rear Compartment

Sg RP Point couple distance	817 (32.2)	827 (32.6)	791 (31.1)	--
Effective head room	961 (37.8)	954 (37.6)	985 (38.8)	--
Effective T Point head room	957 (37.7)	959 (37.8)	991 (39.0)	--
Min. effective leg room	923 (36.3)	965 (38.0)	902 (35.5)	--
Sg RP — second to heel	261 (10.3)	298 (11.7)		--
Knee clearance	53 (2.1)	44 (1.7)	13 (0.5)	--
Compartment room	678 (26.7)	705 (27.8)	685 (27.0)	--
Shoulder room	1419 (55.9)	1450 (57.1)		--
Hip room	1394 (54.9)	1412 (55.6)		--
** Upper body opening to ground	--			--

Luggage Compartment

Usable luggage capacity — L (cu. ft.)	458 (16.2)	469 (16.6)	--	1005.4 (35.5)
** Lifter height	620 (24.4)	807 (31.8)	584 (23.0)	640.1 (25.2)

All linear dimensions are in millimeters (inches).

** EPA LOADED VEHICLE WEIGHT, LOADING CONDITIONS

ALL INTERIOR DIMENSIONS ARE MEASURED WITH THE SEATING REFERENCE POINT (SgRP) _____ mm (1 SEAT ADJUSTER NOTCH) FORWARD OF REAR MOST SEAT POSITION.

MVMA Specifications Form Passenger Car

METRIC (U.S. Customary)

Car and Body Dimensions See Key Sheets for definitions

Car Line MONTE CARLO-MALIBU CLASSIC-EL CAMINO
 Model Year 1982 Issued 8-81 Revised (*) 10-81

Body Type	SAE Ref. No.	MALIBU STATION WAGON
-----------	--------------	----------------------

Station Wagon -- Third Seat

Shoulder room	W85	NOT
Hip room	W86	APPLICABLE
Effective leg room	L86	
Effective head room	H86	
Effective T-point head room	H89	
Seat facing direction	SD1	

Station Wagon -- Cargo Space

Cargo length -- open -- front	L200	2639 (103.9)
Cargo length -- open -- second	L201	1840 (72.4)
Cargo length -- closed -- front	L202	2064 (81.3)
Cargo length -- closed -- second	L203	1265 (49.8)
Cargo length at belt -- front	L204	1852 (72.9)
Cargo length at belt -- second	L205	1023 (40.3)
Cargo width -- wheelhouse	W201	1108 (43.6)
Rear opening width at floor	W203	1372 (54.0)
Opening width at belt	W204	1312 (51.7)
Max rear opening width above belt	W205	1006 (39.6)
Cargo height	H201	763 (30.0)
Rear opening height	H202	706 (27.8)
Tailgate to ground height	H250	584 (23.0)
Front seat back to load floor height	H197	
Cargo volume index -- m ³ (ft ³)	V2	2049 (72.4)
Hidden cargo volume -- m ³ (ft ³)	V4	

Hatchback -- Cargo Space

Front seat back to load floor height	H197	
Cargo length at front seat back height	L208	NOT
Cargo length at floor -- front	L209	APPLICABLE
Cargo volume index -- m ³ (ft ³)	V3	
Hidden cargo volume -- m ³ (ft ³)	V4	

A printed or computer tape supplement containing additional car and body dimensions and/or drawings (based in part on SAE J1100a Motor Vehicle Dimensions) may be available from the manufacturer.
 All dimensions are in millimeters (inches)

MVMA Specifications Form

Passenger Car

METRIC (U.S. Customary)

Car and Body Dimensions See Key Symbols for definitions

Car Line MONTE CARLO-MALIBU CLASSIC-EL CAMINO
 Model Year 1982 Issued 8-81 Revised (*) 10-81

Body Type

MONTE CARLO 2-DOOR COUPE	MALIBU CLASSIC 4-DOOR SEDAN	MALIBU CLASSIC STATION WAGON	EL CAMINO SEDAN PICK-UP
--------------------------------	-----------------------------------	------------------------------------	-------------------------------

Vehicle Fiducial Marks

Fiducial Mark Number *	Define Coordinate Location			
Front	X -	Fiducial mark to vertical base grid line-front, measured horizontally from the base grid line to the front fiducial mark located on top of the front seat adjuster mounting bolt.		
	Y -	Fiducial mark to centerline of car-front, width measurement made from centerline of car to fiducial mark located on top of the front seat adjuster mounting bolt.		
	Z -	Fiducial mark to horizontal base grid line-front, measured vertically from base grid line to front fiducial mark located on top of the front seat adjuster mounting bolt.		
Rear	X -	Fiducial mark to vertical base grid line-rear measured horizontally from base grid line to the rear fiducial mark located on rear underbody crossbar.		
	Y -	Fiducial mark to centerline of car-rear, width measurement made from centerline of car to fiducial mark located on the rear underbody crossbar.		
	Z -	Fiducial mark to horizontal base grid line-rear, measured vertically from base grid line to the rear fiducial mark located on rear underbody crossbar.		
Fiducial Mark Number	W21	564.0 (22.0)		
	L54	2761.0 (108.7)		
	H81	490.0 (19.3)		
	H161	341.5 (13.4)	350.0 (13.8)	
	** H163	322.0 (12.6)	329.0 (12.9)	333.0 (13.1)
	Rear	W22	534.0 (21.0)	560.0 (22.1) 586.0 (23.1)
L55		5338.0 (210.2)	5345.0 (210.4) 5650.0 (222.4)	
H82		617.0 (24.3)	617.0 (24.3) 671.0 (26.4)	
H162		468.0 (18.4)	492.0 (19.3) 547.0 (21.5)	
** H164		449.2 (17.7)	470.0 (18.5) 475.0 (18.7) 532.0 (20.9)	

* Reference — SAE Recommended Practice, J182a, Motor Vehicle Fiducial Marks — September, 1973.
 All linear dimensions are in millimeters (inches).

** EPA LOADED VEHICLE WEIGHT, LOADING CONDITIONS
 MVMA-C-82

MVMA Specifications Form

Passenger Car

Car Line MONTE CARLO-MALIBU CLASSIC-EL CAMINO
 Model Year 1982 Issued 8-81 Revised (*) 10-81

METRIC (U.S. Customary)

Car and Body Dimensions See Key Sheets for definitions

Body Type -

SAE Ref. No.	MONTE CARLO	MALIBU	MALIBU	EL CAMINO
	2-DOOR COUPE	4-DOOR SEDAN	STATION WAGON	SEDAN PICK-UP

Glass

Backlight slope angle	H121	33.0°	32.0°	37.5°	20.0°
Windshield slope angle	H122	58.5°	55.0°	55.0°	58.5°
Tumble-Home	W122	23.5°	24.5°	24.5°	23.5°
Windshield glass exposed surface area - cm ² (in ²)	S1	8786.3(1361.9)	8111.1(1257.2)	8111.1(1257.2)	8786.3(1361.9)
Side glass exposed surface area - cm ² (in ²)	S2	9060.5(1404.4)	9985.5(1547.8)	15637(2423.7)	6944.0(1076.3)
Backlight glass exposed surface area - cm ² (in ²)	S3	4660.0(722.3)	3907 (605.6)	4987.0(773.0)	3314.0(513.7)
Total glass exposed surface area - cm ² (in ²)	S4	22506.8(3488.6)	22003.7(3410.6)	28735.1(4453.9)	19044.3(2951.9)
Windshield glass type		Curved - Laminated Plate			
Side glass type		Curved - Tempered Plate			
Backlight glass type		Curved - Tempered Plate			

Lamps and Headlamp Shape*

Height above ground to center of bulb or marker	Headlamp (H127)	Highest**	672 (26.4)	668 (26.3)	671 (26.4)	670 (26.4)
		Lowest	658 (25.9)	--	--	--
	Taillamp (H128)	Highest	783 (30.8)	671 (26.4)	427 (16.7)	426 (16.8)
		Lowest	683 (26.9)	--	--	--
	Sidemarker	Front	396 (15.6)	637 (25.1)	640 (25.2)	639 (25.2)
		Rear	378 (14.8)	671 (26.4)	435 (17.1)	420 (16.5)
Distance from C/L of car to center of bulb	Headlamp	Inside				
		Outside**				
	Taillamp	Inside				
		Outside				
	Directional	Front				
		Rear				
Headlamp shape						

* Measured at curb mass (weight)

** If single headlamps are used enter here

MVMA Specifications Form
Passenger Car
METRIC (U.S. Customary)

Exterior Car And Body Dimensions – Key Sheet

Exterior Width

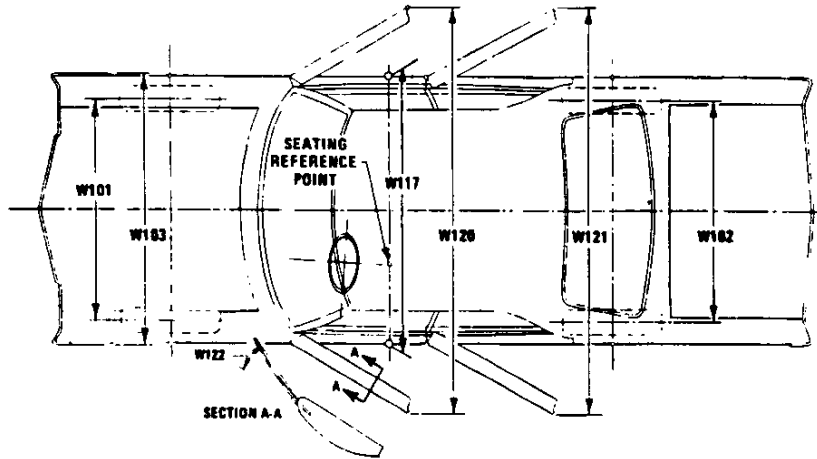

Exterior Length & Height

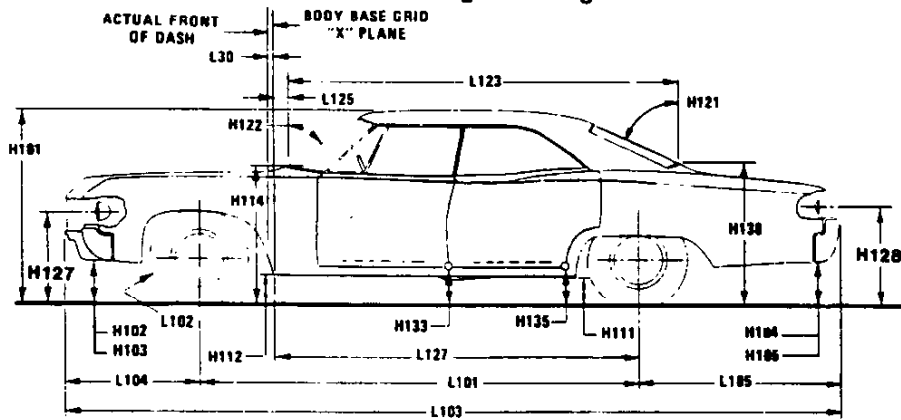

Exterior Ground Clearance

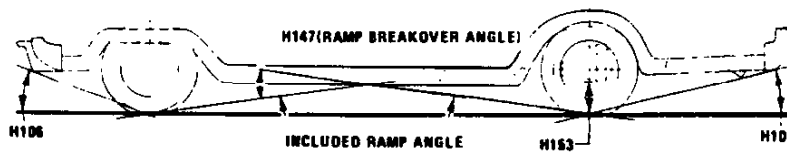

Cargo Space

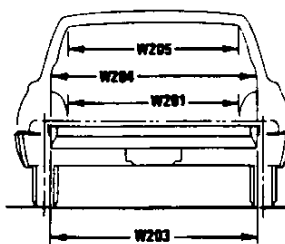
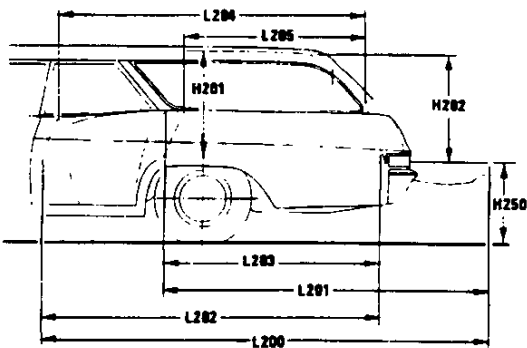

Station Wagon

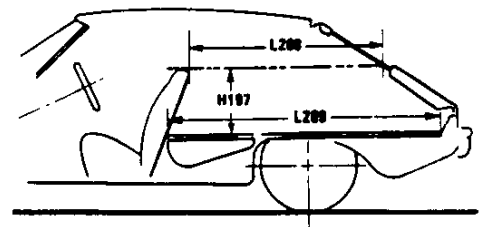

Hatchback

MVMA Specifications Form
Passenger Car
 METRIC (U.S. Customary)

Interior Car And Truck Dimensions — Key Sheet

Front Compartment

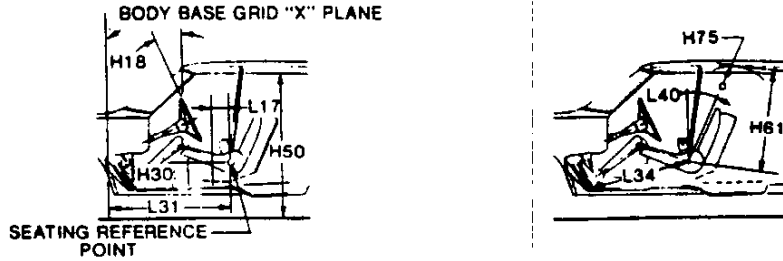

Rear Compartment

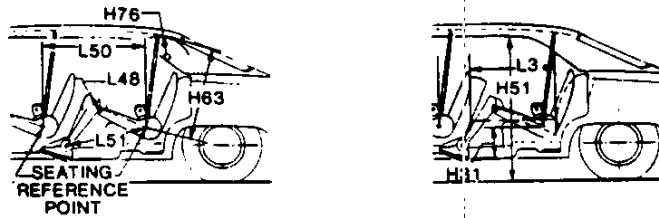

Third Seat

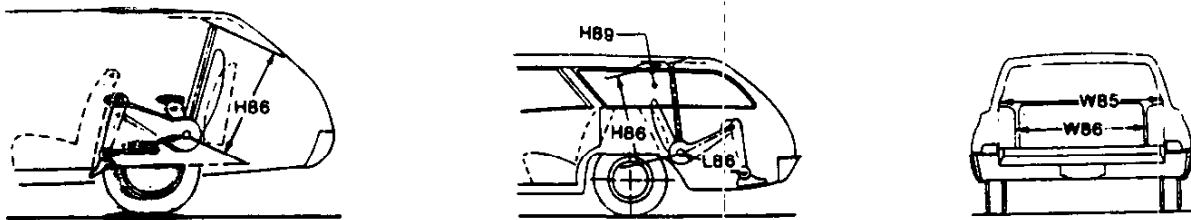

Interior Width

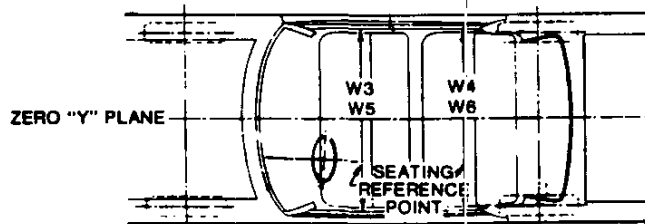

MVMA Specifications Form Passenger Car

METRIC (U.S. Customary)

Exterior Car And Body Dimensions -- Key Sheet Dimensions Definitions

Seating Reference Point

SEATING REFERENCE POINT means the manufacturer's design reference point which --
(a) Establishes the rearward normal design driving or riding position of each designated seating position in a vehicle;
(b) Has coordinates established relative to the design vehicle structure;
(c) Simulates the position of the pivot center of the human torso and thigh;
(d) Is the reference point employed to position the two dimensional templates described in SAE Recommended Practice J826, "Manikins for Use in Defining Vehicle Seating Accommodations," November 1962.

Width Dimensions

- W101 TREAD--FRONT The dimension measured between the tire centerlines at the ground.
- W102 TREAD--REAR. The dimension measured between the tire centerlines at the ground. In case of dual wheels, the dimension will be measured to the centerline of tire and wheel assemblies.
- W103 VEHICLE WIDTH The maximum dimension measured between the widest point on the vehicle, excluding exterior mirrors, flexible flaps, marker lamps, but including bumpers, moldings, sheet metal protrusions or dual wheels, if standard equipment.
- W117 BODY WIDTH AT SGRP--FRONT. The dimension measured laterally between the widest points on the body at the SGRP-front, excluding door handles, applied moldings, or appliques.
- W120 VEHICLE WIDTH--FRONT DOORS OPEN. The dimension measured between the widest point on the front doors in maximum hold-open position.
- W121 VEHICLE WIDTH--REAR DOORS OPEN. The dimension measured between the widest point on the rear doors in maximum hold-open position. For vehicles with a rear door on only one side, this dimension is to the zero "Y" plane.
- W122 TUMBLE HOME. STRAIGHT SIDE GLASS. The angle measured from a vertical to the outside surface of the front door glass at the SGRP "X" plane.
CURVED SIDE GLASS. The angle measured from a vertical to a chord extending from the upper DLO to the lower DLO at the outside surface of the front door glass at the front SGRP "X" plane.

Length Dimensions

- L30 FRONT OF DASH "X" COORDINATE. A minus (-) dimension indicates actual front of dash in forward of the zero "X" plane.
- L101 WHEELBASE (WB). The dimension measured longitudinally between front and rear wheel centerlines. In case of dual rear axles, the dimension shall be to the midpoint of the centerlines of the rear wheels.
- L102 TIRE SIZE. As specified by the manufacturer.
- L103 VEHICLE LENGTH. The maximum dimension measured longitudinally between the foremost point and the rearmost point on the vehicle, including bumper, bumper guards, tow hooks and/or rub strips, if standard equipment.
- L104 OVERHANG--FRONT. The dimension measured longitudinally from the centerline of the front wheels to the foremost point on the vehicle including bumper, bumper guards, tow hooks and/or rub strips, if standard equipment.

- L105 OVERHANG--REAR. The dimension measured longitudinally from the centerline of the rear wheels, or in the case of dual rear axles, the dimension shall be the midpoint of the centerlines of the rear wheels, to the rearmost point on the vehicle, including rear bumpers, bumper guards, tow hooks and rub strips, if standard equipment.
- L123 UPPER STRUCTURE LENGTH. The dimension measured longitudinally from the cowl point to the deck point.
- L127 REAR WHEEL CENTERLINE "X" COORDINATE or in the case of dual rear axles, the coordinate shall be in the midpoint of the distance between the rear axle centerlines.
- L125 COWL POINT "X" COORDINATE.

Height Dimensions

- H101 VEHICLE HEIGHT. The dimension measured vertically from the highest point on the vehicle body to ground.
- H114 COWL POINT TO GROUND. Measured at zero "Y" plane.
- H138 DECK POINT TO GROUND. Measured at zero "Y" plane.
- H112 ROCKER PANEL--FRONT TO GROUND. The dimension measured vertically from the foremost point on the bottom of the rocker panels, excluding flanges, to ground.
- H132 BOTTOM OF DOOR OPEN--FRONT TO GROUND. The dimension measured vertically from the bottom outside corner of the door on the lock pillar side, in maximum hold-open position, to ground.
- H111 ROCKER PANEL--REAR TO GROUND. The dimension measured vertically from the bottom of the rocker or side quarter panel at the front of the rear wheel opening, excluding flanges, to ground.
- H134 BOTTOM OF DOOR OPEN--REAR TO GROUND. The dimension measured vertically from the bottom outside corner of the door on the lock pillar side, in maximum hold-open position, to ground.
- H135 BOTTOM OF DOOR CLOSED--REAR TO GROUND. The dimension measured vertically from the bottom outside corner of the door on the lock pillar side, in maximum closed position, to ground.
- H121 BACKLIGHT SLOPE ANGLE. The angle between the vertical reference line and the surface of backlight at vehicle zero "Y" plane. For curve backlight, the angle is to chord of backlight arc from lower DLO to upper DLO.
- H122 WINDSHIELD SLOPE ANGLE. The angle between the vertical reference line and a chord of the windshield are running from the lower DLO to the upper DLO at the vehicle zero "Y" plane. In the case of wrap over glass, the angle to be measured will be formed by a chord 18.0 in. (457 mm) long, drawn from the lower DLO to the intersecting point on the windshield.
- H127 HEADLAMP TO GROUND--CURB WEIGHT. The dimension measured vertically from the centerline of the lowest headlamp lens to ground.
- H128 TAILLAMP TO GROUND--CURB WEIGHT. The dimension measured vertically from the centerline of the upper bulb to ground.

Ground Clearance Dimensions

- H102 FRONT BUMPER TO GROUND. The minimum dimension measured vertically from the lowest point on the front bumper to ground, including bumper guards, if standard equipment.

MVMA Specifications Form

Passenger Car

METRIC (U.S. Customary)

Interior Car And Body Dimensions - Key Sheet

Dimensions Definitions

- H103 FRONT BUMPER TO GROUND—CURB WEIGHT. Measured in the same manner as H104.
- H104 REAR BUMPER TO GROUND. The minimum dimension measured vertically from the lowest point on the rear bumper to ground, including bumper guards, if standard equipment.
- H105 REAR BUMPER TO GROUND—CURB WEIGHT. Measured in the same manner as H104.
- H106 ANGLE OF APPROACH. The angle measured between a line tangent to the front tire static loaded radius are the initial point of structural interference forward of the front tire to ground. The limiting structural component shall be designated.
- H107 ANGLE OF DEPARTURE. The angle measured between a line tangent to the rear tire static loaded radius are the initial point of structural interference rearward of the rear tire to ground. The limiting component shall be designated.
- H147 REAR BREAKOVER ANGLE. The angle measured between two lines tangent to the front and rear tire static loaded radius and intersecting at a point on the underside of the vehicle which defines the largest ramp over which the vehicle can roll.
- H153 REAR AXLE DIFFERENTIAL TO GROUND. The minimum dimension measured from the rear axle differential to ground.
- H156 MINIMUM RUNNING GROUND CLEARANCE. The minimum dimension measured from the sprung vehicle to ground. Specify location.

Front Compartment Dimensions

- PD1 PASSENGER DISTRIBUTION—FRONT.
- L31 SgRP—FRONT "X" COORDINATED.
- H61 EFFECTIVE HEAD ROOM—FRONT. The dimension measured along a line 8 deg. rear of vertical from the SgRP—front to the headlining, plus 4.0 in. (102 mm).
- H75 EFFECTIVE T-POINT HEAD ROOM—FRONT. The minimum radius from the T-point to the headlining plus 30 in. (762 mm).
- L34 MAXIMUM EFFECTIVE LEG ROOM—ACCELERATOR. The dimension measured along a line from the ankle pivot center to the SgRP—front plus 10.0 in. (254 mm) measured with right foot on the undepressed accelerator pedal. For vehicles with SgRP to heel (H30) greater than 18 in., the accelerator pedal may be depressed as specified by the manufacturer. If the accelerator is depressed, the manufacturer shall place foot flat on pedal and note the depression of the pedal.
- H30 SgRP—FRONT TO HEEL. The dimension measured vertically from the SgRP—front to the accelerator heel point.
- L17 DESIGN H-POINT—FRONT TRAVEL. The dimension measured horizontally between the design H-point—front in the foremost and rearmost seat trace positions.
- W3 SHOULDER ROOM—FRONT. The minimum dimension measured laterally between the trimmed surfaces on the "X" plane through the SgRP—front within the belt line and 10.0 in. (254 mm) above the SgRP—front.
- W5 HIP ROOM—FRONT. The minimum dimension measured laterally between the trimmed surfaces on the "X" plane through the SgRP—front within 1.0 in. (25 mm) below and 3.0 (76 mm) above the SgRP—front and 3.0 (76 mm) fore and aft of the SgRP—front.
- H150 UPPER BODY OPENING TO GROUND—FRONT. The dimension measured vertically from the trimmed body opening to the ground on the SgRP—front "X" plane.

- H18 STEERING WHEEL ANGLE. The angle measured from a vertical to the surface plane of the steering wheel.
- L40 BACK ANGLE—FRONT. The angle measured between a vertical line through the SgRP—front and the torso line. If the seatback is adjustable, use the normal driving and riding position specified by the manufacturer.

Rear Compartment Dimensions

- PD2 PASSENGER DISTRIBUTION—SECOND.
- L50 SgRP COUPLE DISTANCE. The dimension measured horizontally from the driver SgRP—front to the SgRP—second.
- H63 EFFECTIVE HEAD ROOM—SECOND. The dimension measured along a line 8 deg. rear of vertical from the SgRP to the headlining, plus 4.0 in. (102 mm).
- H76 EFFECTIVE T-POINT HEAD ROOM—SECOND. Measured in the same manner as H75.
- L51 MINIMUM EFFECTIVE LEG ROOM—SECOND. The dimension measured along a line from the ankle pivot center to the SgRP—second plus 10.0 in. (254 mm).
- H31 SgRP—SECOND TO HEEL. The dimension measured vertically from the SgRP—second to the two dimensional device heel point on the depressed floor covering.
- L48 KNEE CLEARANCE—SECOND. The minimum dimension measured from the knee pivot to the back of front seatback minus 2.0 in. (51 mm).
- L3 COMPARTMENT ROOM—SECOND. The dimension measured horizontally from the back of front seat to the front of the second seatback at a height tangent to the top of the second seat cushion.
- W4 SHOULDER ROOM—SECOND. The minimum dimension measured laterally between trimmed surfaces on the "X" plane through the SgRP—second within 10.0-16.0 in. (254-406 mm) above the SgRP—second.
- W6 HIP ROOM—SECOND. Measured in the same manner as W5.
- H51 UPPER BODY OPENING TO GROUND—SECOND. The dimension measured vertically from the trimmed body opening to the ground on the "X" plane 13.0 in. (330 mm) forward of the SgRP—second.

Luggage Compartment Dimensions

- V1 USABLE LUGGAGE CAPACITY—Total of volumes of individual pieces of standard luggage set plus H-boxes stowed in the luggage compartment in accordance with the procedure described in paragraph 8.2 of SAE-J1100a.
- H195 LIFTOVER HEIGHT. The dimension measured vertically from the luggage compartment lower opening at the zero "Y" plane to ground.

Station Wagon - Third Seat Dimensions

- PD3 PASSENGER DIRECTION—THIRD.
- W85 SHOULDER ROOM—THIRD. Measured in the same manner as W5.
- W86 HIP ROOM—THIRD. Measured in the same manner as W5.
- L86 EFFECTIVE LEG ROOM—THIRD. The dimension measured along a line from the ankle pivot center to the SgRP—third plus 10.0 in. (254 mm).
- H86 EFFECTIVE HEAD ROOM—THIRD. The dimension, measured along a line 8 deg. from the SgRP—third to the headlining rear of vertical plus a constant of 4.0 in. (102 mm).
- H89 EFFECTIVE T-POINT HEAD ROOM—THIRD. Measured in the same manner as H75.

Passenger Car
METRIC (U.S. Customary)

Interior Car And Body Dimensions — Key Sheet
Dimensions Definitions

Station Wagon — Cargo Space Dimensions

- L200 CARGO LENGTH—OPEN—FRONT. The minimum dimension measured longitudinally from the back of the front seatback at the height of the undepressed floor covering to the rearmost point on the undepressed floor covering on the open tailgate or cargo surface if the rear closure is a conventional door type tailgate, at the zero "Y" plane.
- L201 CARGO LENGTH—OPEN—SECOND. The dimension measured longitudinally from the back of the second seatback at the height of the undepressed floor covering on the open tailgate or cargo floor surface if the rear closure is a conventional door type tailgate, at the zero "Y" plane.
- L202 CARGO LENGTH—CLOSED—FRONT. The minimum dimension measured horizontally from the back of the front seat at the height of the undepressed floor covering to the rearmost point on the undepressed floor covering on the closed tailgate or taildoor for station wagons, trucks and mpv's at the zero "Y" plane.
- L203 CARGO LENGTH—CLOSED—SECOND. The dimension measured horizontally from the back of the second seat at the height of the undepressed floor covering to the rearmost point on the undepressed floor covering on the closed tailgate or taildoor for station wagons, trucks and mpv's at the zero "Y" plane.
- L204 CARGO LENGTH AT BELT—FRONT. The minimum dimension measured horizontally from the back of the front seatback at the seatback top to the foremost normal surface of the closed tailgate or inside surface of the cab back panel at the height of the belt, on the zero "Y" plane.
- L205 CARGO LENGTH AT BELT—SECOND. The minimum dimension measured horizontally from the back of the second seatback at the seatback top to the foremost normal surface of the closed tailgate at the height of the belt, on the zero "Y" plane.
- W201 CARGO WIDTH—WHEELHOUSE. The minimum dimension measured laterally between the trimmed wheelhousings at floor level. For any vehicle not trimmed, measure the sheet metal.
- W203 REAR OPENING WIDTH AT FLOOR. The minimum dimension measured laterally between the limiting interferences of the rear opening at floor level.
- W204 REAR OPENING WIDTH AT BELT. The minimum dimension measured laterally between the limiting interferences of the rear opening at belt height or top of pick up box.
- W205 REAR OPENING WIDTH ABOVE BELT. The minimum dimension measured laterally between the limiting interferences of the rear opening above the belt height.

- H201 CARGO HEIGHT. The dimension measured vertically from the top of the undepressed floor covering to the headlining at the rear wheel "X" coordinated on the zero "Y" plane.
- H202 REAR OPENING HEIGHT. The dimension measured vertically from the top of the undepressed floor covering to the upper trimmed opening on the zero "Y" plane with rear door fully open.
- H250 TAILGATE TO GROUND (CURB WEIGHT). The dimension measured vertically from the top of the undepressed floor covering on the lowered tailgate to ground on the zero "Y" plane.
- V2 STATION WAGON
 Measured in inches:

$$\frac{W4 \times H201 \times L204}{1728} = \text{ft.}^3$$
 Measured in mm:

$$\frac{W4 \times H201 \times L204}{109} = \text{m}^3(\text{cubic meter})$$
- V4 HIDDEN CARGO VOLUME. As specified by the manufacturer.

Hatchback — Cargo Space Dimensions

All hatchback cargo dimensions are to be taken with the front seat in full down and rear position, and the rear seat folded down. The hatchback door is in the closed position. (For electrically adjusted seats, see the manufacturer's specifications for Design "H" Point).

- H197 FRONT SEATBACK TO LOAD HEIGHT. The dimension measured vertically from the horizontal tangent to the top of the seatback to the undepressed floor covering.
- L208 CARGO LENGTH AT FRONT SEATBACK HEIGHT. The minimum horizontal dimension from the "X" plane tangent to the rearmost surface of the driver's seatback to the inside limiting interference of the hatchback door on the vehicle zero "Y" plane.
- L209 CARGO LENGTH AT FLOOR—FRONT—HATCHBACK. The minimum horizontal dimension measured at floor level from the rear of the front seatback to the normal limiting interference of the hatchback door on the vehicle zero "Y" plane.
- V3 HATCHBACK.
 Measured in inches:

$$\frac{L208 + L209}{2} \times W4 \times H197$$

$$\frac{\hspace{10em}}{1728} = \text{ft.}^3$$
 Measured in mm:

$$\frac{L208 + L209}{2} \times W4 \times H197$$

$$\frac{\hspace{10em}}{109} = \text{m}^3(\text{cubic meter})$$

MVMA Specifications Form

Passenger Car

METRIC (U.S. Customary)

Index

Subject	Page No.	Subject	Page No.
Alternator.....	12	Lamps and Headlamp Shape.....	29
Automatic Transmission.....	15	Legroom.....	26, 27
Axis, Steering.....	19	Lengths — Car and Body.....	25
Axis, Rear.....	2, 16	Leveling, Suspension.....	20
Axle Shafts.....	16	Lifters, Valve.....	6
Battery.....	12	Linings — Clutch, Brake.....	14, 18
Bearings, Engine.....	5	Lubrication.....	7, 14, 15
Brakes — Parking, Service.....	17, 18	Luggage Compartment.....	26
Camber.....	19	Mass.....	23, 24
Camshaft.....	5	Models.....	1
Capacities		Motor, Starting.....	12
Cooling System.....	9	Muffler.....	7
Fuel Tank.....	8	Passenger Capacity.....	1
Lubricants		Passenger Mass Distribution.....	23
Engine Crankcase.....	7	Passive Restraint System.....	21
Transmission.....	15	Piston (Pins & Rings).....	4
Rear Axle.....	16	Pistons.....	4
Car Models.....	1	Power Brakes.....	18
Car and Body Dimensions		Power, Engine.....	2
Width.....	25	Power Steering.....	19
Length.....	25	Power Teams.....	2
Height.....	25	Propeller Shaft, Universal Joints.....	16
Ground Clearance.....	25	Pumps — Oil, Fuel.....	7, 8
Front Compartment.....	26	Water.....	9
Rear Compartment.....	26	Radiator — Cap, Hoses.....	9
Luggage Compartment.....	26	Ratios — Axle.....	2, 15
Station Wagon — Third Seat.....	27	Compression.....	2
Station Wagon — Cargo Space.....	27	Steering.....	19
Hatchback — Cargo Space.....	27	Transmission.....	2, 14, 15
Carburetor.....	2, 8	Rear Axle.....	2, 15, 16
Caster.....	19	Regulator — Generator.....	12
Choke, Automatic.....	8	Rims.....	17
Clutch — Pedal Operated.....	14	Rings, Piston.....	4
Coil, Ignition.....	13	Rods — Connecting.....	5
Connecting Rods.....	5	Seats.....	21
Convenience Equipment.....	22	Shock Absorbers, Front & Rear.....	20
Cooling System.....	9	Spark Plugs.....	13
Crankshaft.....	5	Speedometer.....	13
Cylinders and Cylinder Head.....	3	Springs — Front & Rear Suspension.....	20
Diesel Engine.....	8	Stabilizer (Sway Bar) — Front & Rear.....	20
Dimension Definitions		Starting System.....	12
Key Sheet — Exterior.....	30, 32	Steering.....	19
Key Sheet — Interior.....	31, 33, 34	Suppression — Ignition, Radio.....	13
Electrical System.....	12, 13	Suspension — Front & Rear.....	20
Emission Controls.....	10, 11	Tail Pipe.....	7
Engine		Theft Protection.....	22
Bore, Stroke, Type.....	3	Thermostat, Cooling.....	9
Compression Ratio.....	2	Timing — Valve.....	6
Displacement.....	2, 3	Tires.....	17
Firing Order, Cylinder Numbering.....	3	Toe-in.....	19
General Information, Power & Torque.....	2	Torque Converter.....	15
Identification Number Location.....	21	Torque — Engine.....	2
Lubrication.....	7	Transaxle.....	15
Power Teams.....	2	Transmission — Types.....	2, 14, 15
Exhaust System.....	7	Transmission — Automatic.....	2, 14, 15
Equipment Availability, Convenience.....	22	Transmission — Manual.....	2, 14, 15
Fan, Cooling.....	9	Transmission — Ratios.....	2, 15
Fiducial Marks.....	28	Tread.....	25
Filters — Engine Oil, Fuel System.....	7	Trunk Cargo Load.....	1
Frame.....	21	Trunk Luggage Capacity.....	26
Front Suspension.....	20	Turning Diameter.....	19
Front Wheel Drive Unit.....	16	Unitized Construction.....	21
Fuel, Fuel Pump, Fuel System.....	3, 8	Universal Joints, Propeller Shaft.....	18
Fuel Injection.....	8	Valves — Intake & Exhaust.....	6
Generator and Regulator.....	12	Vehicle Identification Number.....	21
Glass.....	29	Voltage Regulator.....	12
Headroom — Body.....	26, 27	Water Pump.....	9
Heights — Car and Body.....	25	Weights.....	23, 24
Horns.....	13	Wheel Alignment.....	19
Horsepower — Brake.....	2	Wheelbase.....	25
Ignition System.....	13	Wheels & Tires.....	17
Inflation — Tires.....	17	Wheel Spindle.....	19
Instruments.....	13	Widths — Car and Body.....	25
Kingpin (Steering Axis).....	19	Windshield.....	29
		Windshield Wiper and Washer.....	13