

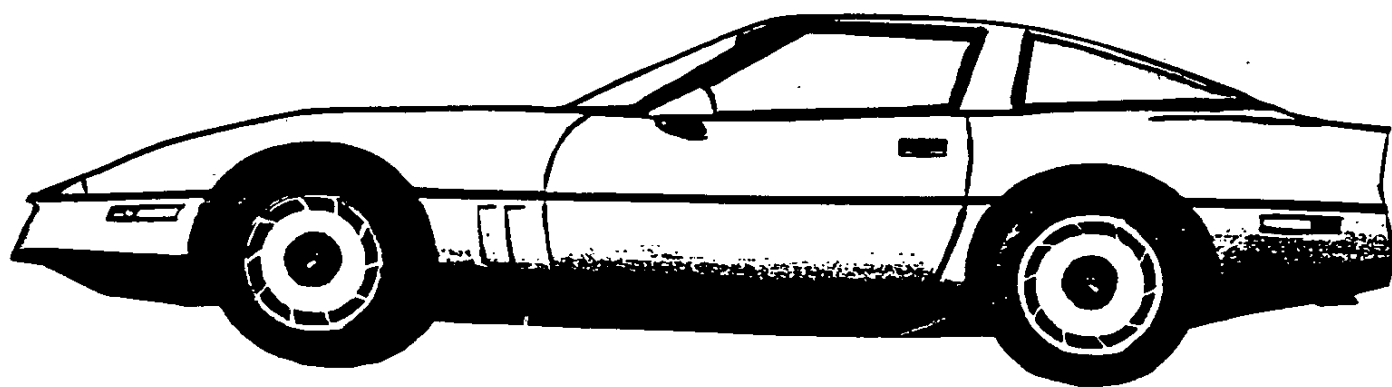



# CORVETTE

## 1984 SPECIFICATIONS



*GENUINE CHEVROLET*



# 1984 CORVETTE

Production: 51,547 coupes

## 1984 NUMBERS

**Vehicle:** 1G1AY0782E5100001 thru 1G1AY0782E5151547  
• Ninth digit is a check code and varies.

**Suffix:** ZFC: 350ci, 205hp, at      ZFL: 350ci, 205hp, mt  
          ZFD: 350ci, 205hp, mt      ZFM: 350ci, 205hp, at, ce  
          ZFF: 350ci, 205hp, at, ce    ZFN: 350ci, 205hp, mt, ce  
          ZFH: 350ci, 205hp, ex      ZFR: 350ci, 205hp, mt, ce  
          ZFK: 350ci, 205hp, at

**Block:** 14010207: All

**Head:** 462624: All

**Abbreviations:** at=automatic transmission, ce=california emissions,  
ci=cubic inch, ex=export, hp=horsepower, mt=manual transmission.

## 1984 FACTS

- The 1984 Corvette was a complete redesign in almost every aspect. Handling considerations dominated and the result was praised by the motoring press as the world's best cornering automobile.
- The 1984 Corvette was introduced in March 1983. Because it met all 1984 federal requirements, Chevrolet decided to skip the 1983 model designation. The result was a very long production run and the second highest model year volume in the Corvette's history. 1983 Corvettes were built, serial numbered, and tested by both Chevrolet and the motoring press at the "long lead" preview at Riverside Raceway in December 1982. But 1983 Corvettes were not released for public sale.
- Design criteria specified that the 1984 Corvette have more ground clearance and more interior room, but less overall height. In order to achieve it, engineers routed the exhaust system through the center tunnel.
- A "4+3", 4-speed manual transmission, built by Doug Nash, had overdrives in the top three gears for improved fuel economy. Not available early.
- All 1984 Corvettes were designed with one-piece, lift-off roof panels and rear hatch windows. At the time, the rear window glass was the largest compound glass ever installed in an American automobile. The front windshield was raked at the greatest angle, 64%.
- Brakes remained disc at all four wheels, but components were new and included aluminum calipers supplied by Girlock of Australia.
- Electronic instrumentation was standard and included digital readouts for engine monitoring and liquid crystal graphic displays for speed and engine revolutions. Analog instrumentation was not available.
- The 1984 Corvette was designed with a pad protruding from the passenger side of the dash. This was part of a passive restraint system conceived when it was assumed the federal regulation would require such restraints. The Reagan Administration dropped the restraint proposals, but the Corvette's pad remained.
- The 1984 Corvette was designed without fiberglass seams on exposed panels to eliminate factory finishing. The exterior seams were under the rub strip extending around the entire body.
- The radiator was a new design using aluminum for the cooling fins and plastic for the reservoirs. A thermostatically controlled electric fan operates only when needed and only under 35mph.
- Chevrolet built specially modified 1984 Corvettes for the export markets of European, Middle East, Japanese, and Latin American countries. Changes included different license plate provisions, leaded fuel capability, and electrical, glass, lighting and mirror modifications.
- Single transverse plastic leaf springs were used front and rear.

## 1984 OPTIONS

RPO #	DESCRIPTION	QTY	RETAIL \$
1YY07	Base Corvette Sport Coupe .....	51,547	\$21,800.00
AG9	Power Driver Seat .....	48,702	210.00
AQ9	Sport Seats, cloth .....	4,003	625.00
AR9	Base Seats, leather .....	40,568	400.00
AU3	Power Door Locks .....	49,545	165.00
CC3	Removable Transparent Roof Panel .....	15,767	595.00
D84	Two-Tone Paint .....	8,755	428.00
FG3	Delco-Bilstein Shock Absorbers .....	3,729	189.00
G92	Performance Axle Ratio .....	410	22.00
KC4	Engine Oil Cooler .....	4,295	158.00
K34	Cruise Control .....	49,832	185.00
MM4	4-Speed Manual Transmission .....	6,443	0.00
QZD	P255/50VR16 Tires/16" Wheels .....	51,547	561.20
UL5	Radio Delete .....	104	-331.00
UM6	AM-FM Stereo Cassette .....	6,689	153.00
UN8	AM-FM Stereo, Citizens Band .....	178	215.00
UU8	Stereo System, Delco-Bose .....	43,607	895.00
V01	Heavy-Duty Radiator .....	12,008	57.00
YF5	California Emission Requirements .....	6,833	75.00
Z51	Performance Handling Package .....	25,995	600.20
Z6A	Rear Window+Side Mirror Defoggers .....	47,680	160.00

- A 350ci, 205hp engine, 4-speed automatic transmission, removable body-color roof panel, and cloth seats were included in the base price.
- Optional leather seats were the same design as the base cloth style. Sport seats were available in cloth (different material than base) and featured inflatable lumbar support and power-adjusted side bolsters.
- The RPO QZD 16-inch tire and wheel package, initially intended to be included as part of the Z51 option, and as a separate option for base models, was required for all 1984 Corvettes sold. The scheduled standard 15-inch alloy wheels and P215/65R15 tires were not used.
- RPO Z51 included heavy-duty front and rear springs, shock absorbers, stabilizer bars and bushings, fast steering ratio, engine oil cooler, extra radiator fan (pusher), P255/50VR16 tires and directional alloy wheels, 16x8.5-inch front, 16x9.5-inch rear.

## 1984 COLORS

CODE	EXTERIOR	QTY	WHEELS	INTERIORS
10	White .....	6,417	Alloy	Ca-Br-Gr-Mb-Mg-S
16	Bright Silver Metallic .....	3,109	Alloy	Gr-Mg
18	Medium Gray Metallic .....	3,147	Alloy	Gr-Mg
19	Black .....	7,906	Alloy	Ca-Gr-Mg-S
20	Light Blue Metallic .....	1,196	Alloy	Mb
23	Medium Blue Metallic .....	1,822	Alloy	Mb
53	Gold Metallic .....	2,430	Alloy	S
63	Light Bronze Metallic .....	2,452	Alloy	Br
66	Dark Bronze Metallic .....	1,371	Alloy	Br
72	Bright Red .....	12,942	Alloy	Gr-S
16/18	Silver/Medium Gray .....	3,629	Alloy	Gr-Mg
20/23	Light Blue/Medium Blue .....	1,433	Alloy	Mb
63/66	Light Bronze/Dark Bronze .....	3,693	Alloy	Br

- Additional codes: 70 and 33 for Bright Red, 41 for Black, 40 for White.
- Suggested interiors shown. Other combinations were possible.
- Interior colors sold in 1984 were 13,752 graphite, 12,768 carmine, 8,019 bronze, 6,685 saddle, 6,541 gray, 3,782 blue.
- All wheels were alloy with similar exterior appearance. Base models had all 16x8.5-inch. Z51 models had 16x8.5-inch front, 16x9.5-inch rear.

**Interior Codes:** 12C=Gr/C, 12V=Gr/Sc, 122=Gr/L, 15C=Mg/C, 15V=Mg/Sc, 152=Mg/L, 28C=Mb/C, 28V=Mb/Sc, 62C=S/C, 62V=S/Sc, 622=S/L, 65C=Br/C, 65V=Br/Sc, 652=Br/L, 742=Ca/L.

**Abbreviations:** Ca=Carmine, Br=Bronze, C=Cloth, Gr=Graphite, L=Leather, Mb=Medium Blue, Mg=Medium Gray, S=Saddle, Sc=Sport Seat Cloth.

# The Corvette Black Book

1953-1993

October 1992

Published by

Michael Bruce Associates, Inc.

Michael Antonick, President

Post Office Box 396

Powell, Ohio 43065



## CONTENTS

Glossary	4	1965 Corvette	44	1981 Corvette	76
Instructions	6	1966 Corvette	46	1982 Corvette	78
Statistics	12	1967 Corvette	48	1984 Corvette	80
Chronology	14	1968 Corvette	50	1985 Corvette	82
1953 Corvette	20	1969 Corvette	52	1986 Corvette	84
1954 Corvette	22	1970 Corvette	54	1987 Corvette	86
1955 Corvette	24	1971 Corvette	56	1988 Corvette	88
1956 Corvette	26	1972 Corvette	58	1989 Corvette	90
1957 Corvette	28	1973 Corvette	60	1990 Corvette	92
1958 Corvette	30	1974 Corvette	62	1991 Corvette	94
1959 Corvette	32	1975 Corvette	64	1992 Corvette	96
1960 Corvette	34	1976 Corvette	66	1993 Corvette	98
1961 Corvette	36	1977 Corvette	68	Notes	100
1962 Corvette	38	1978 Corvette	70	Photos/Specs	104
1963 Corvette	40	1979 Corvette	72	Literature	124
1964 Corvette	42	1980 Corvette	74	Coupons	127

© Michael Bruce Associates, Inc., 1978, 1980, 1983, 1985, 1988, 1991, 1992. All rights reserved under Pan American and Universal Copyright Conventions by Michael Bruce Associates, Inc. Reproduction without permission is prohibited. Because of the possibility of errors, exceptions, or other reasons for inaccuracy, the publisher and author disclaim responsibility for the accuracy of any or all information presented in this publication.

Michael Bruce Associates, Inc. acknowledges with appreciation the following enthusiasts who contributed their expertise to this and previous editions of the *Corvette Black Book*: Roland Adams, Dan Aldridge, John Angwert, Pal Baker, Jane Barthelme, Michele Bolling, Kent Brooks, Barry Brown, David Burroughs, Steve Dangremont, Dr. M. F. Dobbins, Bob Eckles, the late Sam Folz, John Hobert, Mike Hunt, Alan Kaplan, Paul Kitchen, Gary Komter, Ralph Kramer and staff, Jim Krughoff, Gary Lusk, Bill Locke, Bob Lojewski, Bob McDorman, Chip Miller, Bill Mock, Brian Pearce, John Poloney, Bill Rhodes, Jeffrey Smith, Mark & Dixie Smith, Lou Vitale, Jerry Wadsworth, Jerry Weichers and Don Williams. Thanks also to Callaway Engineering, to Mercury Marine, and to the Chevrolet Motor Division of General Motors Corporation.

**Notice:** *The Corvette Black Book* and its publisher, Michael Bruce Associates, Inc. have no relationship or connection whatever with Hearst Business Media Corporation, its parent or affiliated corporations, or the *Black Book* published by National Auto Research Division of Hearst Business Media Corporation.

Michael Bruce Associates, Inc. and the *Corvette Black Book* are not associated with or sponsored by General Motors or its Chevrolet Motor Division.

**Cover:** Photo and design by Mike Antonick. 1963 Corvette owned by Bill Munzer; restored by Bill Munzer and Don Williams.

Printed and bound in the United States of America

ISBN: 0-933534-35-3

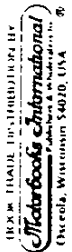

## BLACK BOOK ORDER FORM

Send \_\_\_\_\_ copies of the

**Corvette Black Book 1953-1993**

@ \$11.95 each \$ \_\_\_\_\_

Ohio residents add .72 sales tax \_\_\_\_\_

Postage/hard shipping container 3.00 \_\_\_\_\_

Check or money order enclosed \$ \_\_\_\_\_

Name \_\_\_\_\_

Street \_\_\_\_\_

City \_\_\_\_\_ State \_\_\_\_\_ Zip \_\_\_\_\_

Mail Order To: Michael Bruce Associates, Inc.  
Post Office Box 396  
Powell, Ohio 43065



## BLACK BOOK ORDER FORM

Send \_\_\_\_\_ copies of the

**Corvette Black Book 1953-1993**

@ \$11.95 each \$ \_\_\_\_\_

Ohio residents add .72 sales tax \_\_\_\_\_

Postage/hard shipping container 3.00 \_\_\_\_\_

Check or money order enclosed \$ \_\_\_\_\_

Name \_\_\_\_\_

Street \_\_\_\_\_

City \_\_\_\_\_ State \_\_\_\_\_ Zip \_\_\_\_\_

Mail Order To: Michael Bruce Associates, Inc.  
Post Office Box 396  
Powell, Ohio 43065

1  
2  
3  
4  
5  
6  
7  
8  
9  
10  
11  
12  
13  
14  
15  
16  
17  
18  
19  
20  
21  
22  
23  
24  
25  
26  
27  
28  
29  
30  
31  
32  
33  
34  
35  
36  
37  
38  
39  
40  
41  
42  
43  
44  
45  
46  
47  
48  
49  
50  
51  
52  
53  
54  
55  
56  
57  
58  
59  
60  
61  
62  
63  
64  
65  
66  
67  
68  
69  
70  
71  
72  
73  
74  
75  
76  
77  
78  
79  
80  
81  
82  
83  
84  
85  
86  
87  
88  
89  
90  
91  
92  
93  
94  
95  
96  
97  
98  
99  
100

# 1984 GENERAL MOTORS PASSENGER CAR VEHICLE IDENTIFICATION NUMBERING (VIN) SYSTEM

(1)(2)(3)	(4)	(5)	(6)	(7)	(8)	(9)	(10)	(11)	(12) thru (17)	
DIVISION/ MAKE		RESTRAINT SYS TYPE	CARLINE/ SERIES	BODY TYPE		ENGINE CODE	CHECK DIGIT	MODEL YEAR	PLANT CODE	PRODUCTION SEQUENCE NUMBER
1 G 1		A	Z	3	7	A	1	E	R	1 0 0 0 0 1

DIVISION CODE MAKE	
1G1	Chevrolet Passenger
1G2	Pontiac Passenger
1G3	Oldsmobile Pass
1G4	Buick Passenger
1G6	Cadillac Passenger
1G7	GM of Canada Pass
1GC	Chevrolet Truck
1GT	GMC Truck
J8C	Chevrolet Truck
1G8	Chevrolet MPV
1G5	GMC Truck MPV
* GM merchandised vehicle built by Isuzu Motors Fujisawa Japan	

RESTRAINT SYSTEM TYPE	
CODE	RESTRAINT SYSTEM
A	Non Passive Restraint Manual Belts - A77

CAR LINE . SERIES	
<b>CHEVROLET (Code 1)</b>	<b>OLDSMOBILE (Code 3)</b> Cont'd
B-Chevette	L-Delta 88
C-Cavalier Cadet	M-Cutlass Supreme Brougham(47-69)
D-Cavalier GS	M-Cutlass Ciera
E-Cavalier(Type 10)	J-Chevette Scooter Brougham(19-27)
H-Citation Coupe	N-Delta 88 Royale
J-Chevette Scooter	P-Custom Cruiser
L-Imbala	R-Cutlass Supreme
N-Cadence Classic	W-98 Regency Brougham (FWD)
P-Camaro Sport Coupe	X-98 Regency (FWD)
S-Camaro Berlietta	Y-Delta 88 Royale Brougham
W-Celebrity(19-27)	Z-Toronado Brougham
W-Malibu Classic (35-69)	
X-Citation	
Y-Corvette	
Z-Monte Carlo	
<b>PONTIAC (Code 2)</b>	<b>BUICK (Code 4)</b>
B-J2000	B-Skylark Custom
C-J2000 LE	C-Skylark Limited
D-J2000 SE	D-Skylark Sport(T Type)
E-Fiero Coupe	E-Skyhawk(T Type)
F-Fiero SE Coupe(37)	F-Electra(T Type)(FWD)
F-Pontiac 6000(19-27-35)	G-Century Sport(T Type)
G-Pontiac 6000 LE	H-Century Custom
H-Pontiac 6000 STE	J-Regal
J-Grand Prix	K-Regal Sport(T Type)
K-Grand Prix LE	L-Century Limited
L-T1000(08-68)	M-Regal Limited
L-Parisienne(35-69)	N-LeSabre Custom
M-Fiero Sport Coupe	P-LeSabre Limited
N-Bonneville	R-Electra Limited(RWD)
P-Grand Prix Brougham	S-Skyhawk Custom
R-Bonneville Brougham	T-Skyhawk Limited
S-Firebird(87)	U-Electra Park Avenue (RWD)
S-Bonneville(69)	V-Electra Estate
T-Phoenix SE	W-Electra Park Avenue (FWD)
T-Parisienne Brougham (69)	X-Electra Limited(FWD)
W-Firebird Trans Am	Y-Riviera "T"
X-Firebird Special Edition	Z-Riviera Luxury
Y-Phoenix	
Z-Phoenix LE	
<b>OLDSMOBILE (Code 3)</b>	<b>CADILLAC</b>
B-Omega	B-Fleetwood(FWD)
C-Firenza	D-Deville(FWD)
D-Firenza Brougham	F-Fleetwood Limousine
E-Omega Brougham	G-Cimarron
G-98 Regency (RWD)	L-Eldorado
H-98 Regency Brougham (RWD)	M-Deville(RWD)
J-Cutlass Ciera LS	S-Seville
K-Cutlass Calais	W-Fleetwood Brougham (RWD)
	<b>GMC TRUCK &amp; COACH</b>
	W-Caballero

ENGINE CODES					
CODE	LITERS	CARB	USAGE	PROD	DIV
A	3.8L	V6	2	1234	4
B	2.0	L4	2	1234	1
C	1.6	L4	2	12	1
D	1.8	L4	Dies	12	1
E	3.0	V6	2	34	4
F	2.5	L4	2	12	2
G	5.0	V8	4	12	1
H	5.0	V8	4	1234	1
L	2.8	V6	2	2	2
N	5.7	V8	Dies	12346	3
P	2.0	L4	TBI	12346	1
R	2.5	L4	TBI	1234	2
S	5.0	V8	TBI	12	1
T	4.3	V6	Dies	1234	3
V	4.3	V6	Dies	1234	3
X	2.8	V6	2	1234	1
Y	5.0	V8	4	34	3
Z	2.8	V6	2	1234	1
0	1.8	L4	TBI	234	2
1	2.8	V6	2	12	1
2	2.5	L4	TBI	12	2
4	4.1	V6	4	346	4
5	2.5	L4	2	1234	2
6	5.7	V8	4	1	1
7	5.0	V8	4	12	1
8	5.7	V8	TBI	1	1
8	3.8	V6	4	4	4
8	4.1	V8	DFI	6	6
9	6.0	V8	DFI	6	6
9	3.8	V6	2	12	1
9	5.0	V8	4	3	3

NOTE. DIVISION / MAKE  
 1st Position = Country  
 1 = United States  
 2 = Canada  
 J = Japan

2nd Position = Manufacture  
 G = General Motors

3rd Position = Division  
 1 = Chevrolet  
 2 = Pontiac  
 3 = Oldsmobile  
 4 = Buick  
 6 = Cadillac  
 7 = Canada  
 Z = Isuzu (Luv)

\* BODY TYPE - SEE MODEL CHART



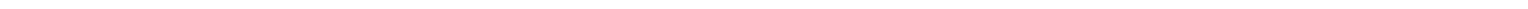

# ENGINE ASSEMBLY IDENTIFICATION

## CHEVROLET ENGINE PRODUCTION CODE

Chevrolet produced engines are stamped with a source, production date and engine suffix. Other General Motors produced engines used in Chevrolet vehicles will use a label affixed to the engine assembly. A complete list of all alphabetic codes used, regardless of manufacturer, appear in the following pages.

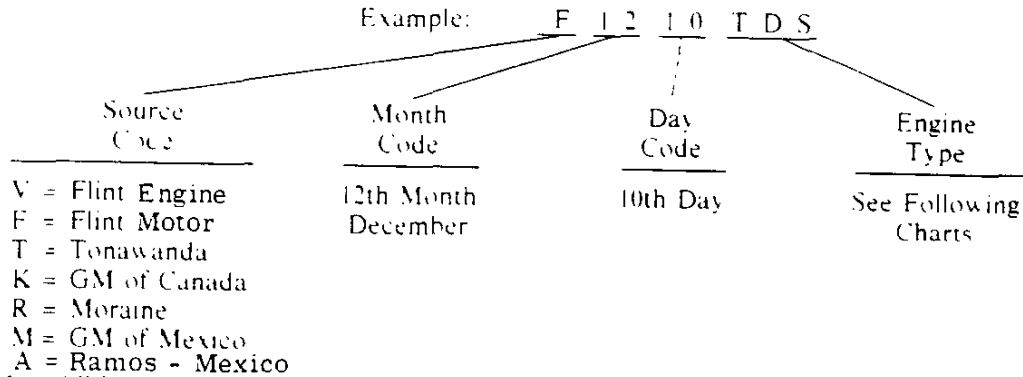

In addition, all engines have a portion of the vehicle identification number stamped near the engine production code. This consists of the division code, model year, assembly plant and vehicle build sequence number.

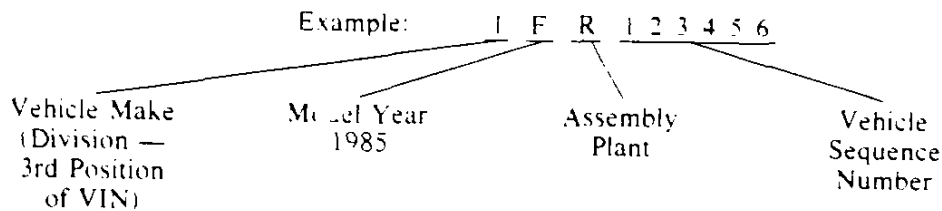

**\*NOTE:** Pre 1980 production used numerical characters (last digit of model year) to identify model year. 1980 started the progressive use of alphabetic characters.

### (1) DIVISION

#### (PRIOR TO 1979)

- 1 — Chevrolet
- 2 — Pontiac
- 3 — Oldsmobile
- 4 — Buick
- 5 — GMC Truck
- 6 — Cadillac
- 7 — GM of Canada

#### Since 1979

- 1 — Chevrolet
- 2 — Pontiac
- 3 — Oldsmobile
- 4 — Buick
- 5 — GM Overseas
- 6 — Cadillac
- 7 — GM of Canada
- 8 —
- 9 — GM Overseas
- C — Chev. Truck
- T — GMC Truck

### (3) PLANT

- A — Lakewood
- B — Baltimore
- C — Lansing (B)
- D — Doraville
- E — Linden
- F — Flint (Chev.)
- G — Framingham
- H — Flint (Buick)
- J — Janesville
- K — Kosai
- K — Leeds
- L — Van Nuys
- M — Lansing
- N — Norwood
- P — Pontiac (Pont.)

Q — Detroit (Not used in 1980)

- R — Arlington
- S — St. Louis
- S — Ramos Arizpe
- T — Tarrytown
- U — Hamtramck
- V — Pontiac (GMC)
- W — Willow Run
- X — Fairfax
- Y — Wilmington
- Z — Fremont
- 1 — Wentzville
- 1 — Oshawa #2
- 2 — Moraine (T&B)
- 2 — St. Therese
- 3 — Detroit (T&B)
- 3 — St. Eustache
- 3 — Kawasaki
- 4 — Orion
- 4 — Scarborough
- 5 — Bowling Green
- 5 — London
- 6 — Oklahoma City
- 7 — Lordstown
- 8 — Shreveport
- 8 — Fujisawa, Japan (I.T.O.)
- 9 — Detroit (Old)
- 9 — Oshawa #1
- 0 — GM Truck Pontiac

**3.3, 3.8, 4.3, 4.4, 5.0, 5.7 AND 6.6 LITER  
GASOLINE 90° V-BLOCK — CHEVROLET**

The code is stamped on a cylinder case pad immediately forward of the right hand cylinder head.

OR

The code may be on the vertical surface rearward of the oil filter location.

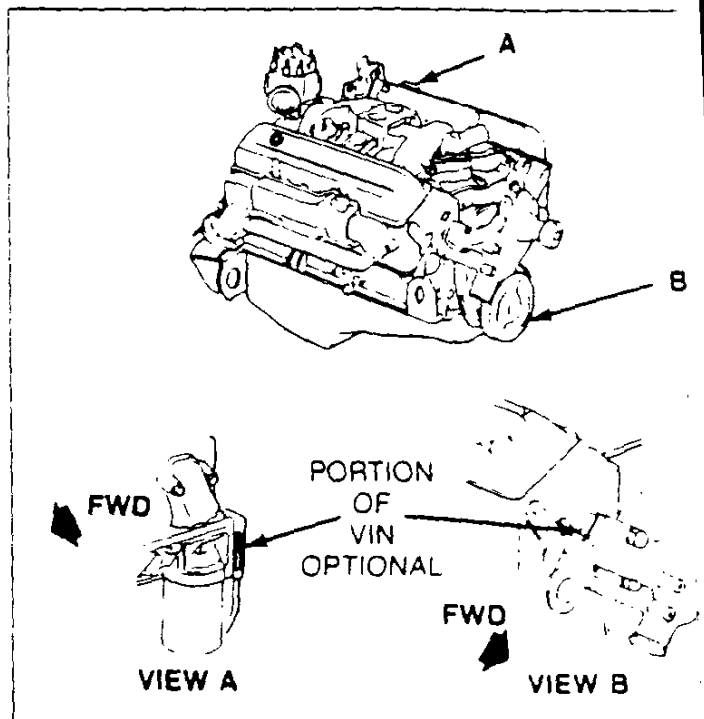

**ENGINE ASSEMBLY CODES IDENTIFICATION**

**1984**

5.7(350-8) - L83  
VIN B  
ZFC ZFO ZFF ZFN  
ZFM

**TRANSMISSION AND ENGINE USAGE**

**1984**

<u>VIN CODE</u>	<u>CUBIC DISP</u>	<u>LITER TYPE</u>	<u>ENGINE TYPE</u>	<u>FUEL TYPE</u>	<u>ENGINE OPT.</u>	<u>SERIES USAGE</u>	<u>TRANSMISSION USAGE</u>
8	350	5.7	V8	TBI	L83	Y	MD8, MK2
<u>AUTO TRANS.</u>				<u>MAN. TRANS.</u>			
MD8	THM700R4	4 SPEED		MK2	4 SPEED		

**TRANSMISSION IDENTIFICATION CODE**

**1984 - 1985**

MD8 - 4 SPD A.T.  
THM700  
Y9

MK2 - 4 SPD M.T.  
50Y

## REAR AXLE FIELD IDENTIFICATION

Axles are manufactured by Buick, Chevrolet Buffalo, Chevrolet Warren, Chevrolet Gear and Axle, Oldsmobile, Pontiac and McKinnon. Divisional Manufacturer code letters will be metal stamped on the axle tube adjacent to the carrier for field identification (See example). Metal stamped on right front inboard side, letters and numerals 1/4" high, 3" outboard of carrier or are located on a metal tag attached to cover bolt. Reference should be made to divisional service manuals for location on some models.

### FIELD IDENTIFICATION

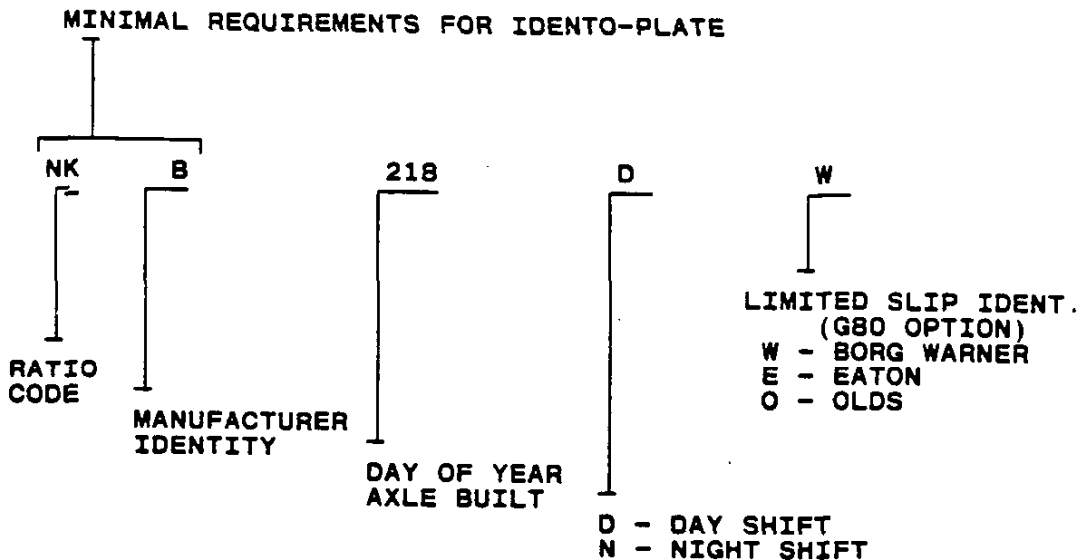

### MANUFACTURER IDENTITY

B - BUICK	G - CHEVROLET GEAR AND AXLE
O - OLDSMOBILE	C - CHEVROLET BUFFALO
P - PONTIAC	K - GM OF CANADA, ST. CATHERINES (MCKINNON)
M - PONTIAC/CANADA	W - CHEVROLET WARREN

MANUFACTURERS IDENTIFICATION WILL APPEAR IN THE DESCRIPTION COLUMN OF CATALOG.

### AXLE IDENTIFICATION CODES

**1984**

3.07 RATIO - HE3 OPT

4CC 4CF 4CH 4CJ  
4CN 4CS 4YJ

3.31 RATIO - GW4 OPT

4CB 4CK 4CR

# 1984 CORVETTE

## ORDERING INFORMATION

CORVETTE Sport Coupe Model Number 1YY07

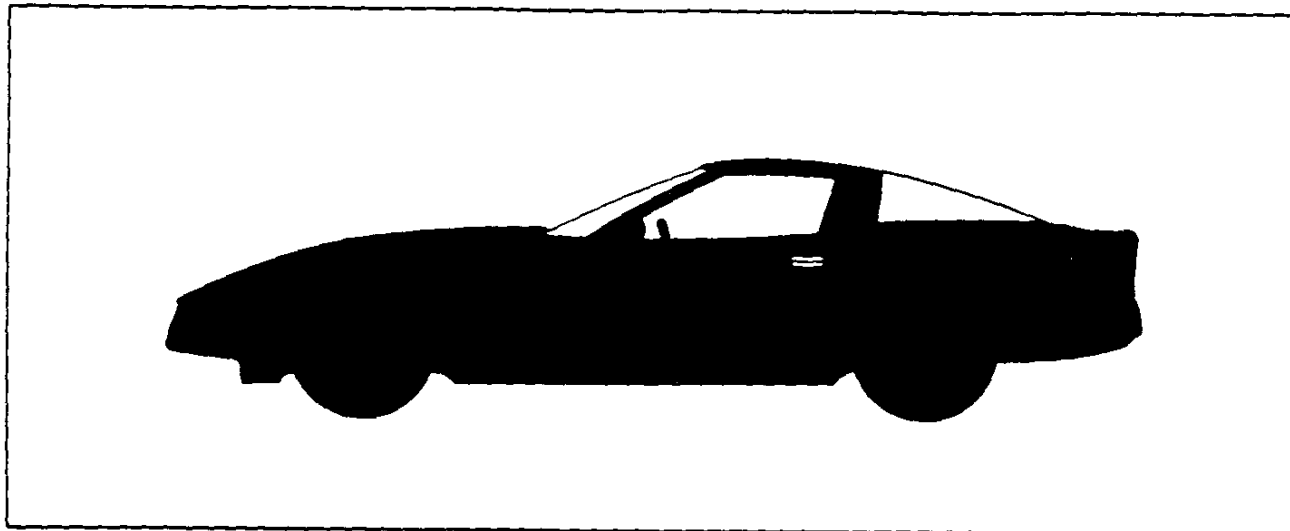

### NEW FEATURES

- The first completely new Corvette in over fifteen years!
- Combines the outstanding features of past Corvettes into the sleekest shape in Corvette history
- Front engine, rear-wheel drive—lighter in weight and trimmer in length
- New uniframe-design body structure with corrosion-resistant coating.
- Clamshell-opening front end assembly for easy engine access
- Full-glass rear hatch with three remote releases and roller-shade cargo cover
- One-piece fiberglass roof panel with special remover
- Independent front and rear suspension, each with fiberglass transverse leaf spring and forged A-arms.
- Rack-and-pinion steering—power assisted.
- Ultra-contemporary instrument panel features electronic liquid-crystal instrumentation with multi-colored analog and digital display in either English or Metric readout.
- Numeric readout of engine and electrical conditions.
- Driver information system with instant MPG, average MPG and range readouts.
- Electronically tuned, seek-and-scan AM/FM stereo with digital clock and 4-speaker system.
- Side-window defoggers, halogen fog lamps and rear corner backup lamps.
- Electrically adjusted outside mirrors and automatic power antenna.
- Cloth seats with lateral support and back-angle adjustments plus wool-pad comfort liner.
- Full-leather bucket seats available.
- Cast alloy road wheels and Goodyear Eagle GT steel-belted radial tires.
- Improved performance.
- Now available: Ultra-high performance Delco Bose sound system

### CONTINUED FEATURES

- Power steering and power four-wheel disc brakes.

- Air conditioning and power windows
- Anti-theft alarm system with starter-interrupt feature
- Power-operated, retractable halogen headlamps
- Full instrumentation with trip odometer and tachometer
- Computer Command Control
- 5.7 Liter CFI V8 engine (Cross-Fire Injection)
- Automatic transmission with overdrive fourth gear
- Aluminum intake manifold with tuned runners
- Stainless steel exhaust manifolds and free-flow mufflers
- Hydraulic valve lifters and exhaust valve rotators
- Magnesium valve rocker covers and air cleaner cover
- Cold-air induction system.
- Electric in-tank twin turbine fuel pump
- High Energy Ignition system
- Second-generation Freedom Plus II battery with 100 amp terminals.
- Delcotron generator with built-in solid-state regulator
- Side-lift jack.
- Front cornering lamps and underhood lamp
- Automatic speed control available.
- Power door locks available.
- Soft-padded and carpeted door panels
- Rear window defogger available.
- Headlamp-on reminder.
- Leather-wrapped steering wheel.
- Tilt-Telescopic steering wheel & column
- Glove compartment lock and lamp.
- Intermittent windshield wipers.
- Cigarette lighter and ashtray.
- Center console with shifter, coin tray, window, air conditioning and outside sport mirror controls
- Day/night rearview mirror.
- Deep-twist floor and stowage area carpet
- Acoustical insulation package.

Refer to Dealer Order Guide for option availability and application.

# 1984 CORVETTE INTERIORS

## CORVETTE Standard Interior



Graphite

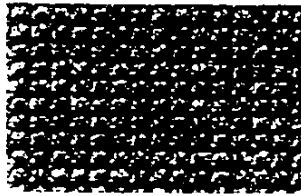

Gray



Blue



Bronze

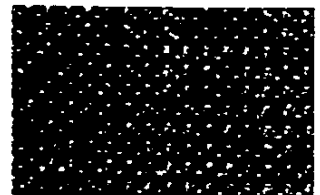

Saddle

## LEATHER Corona

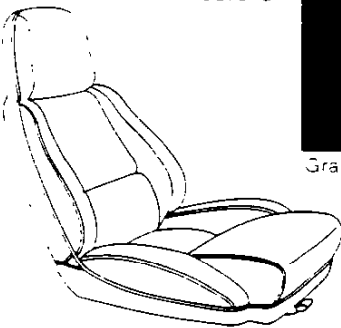

Graphite



Gray



Bronze

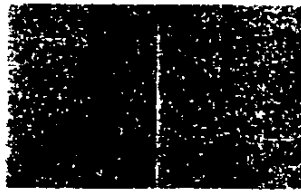

Saddle



Dark Red

## CORVETTE Special Optional Seat\* Interior

### CLOTH

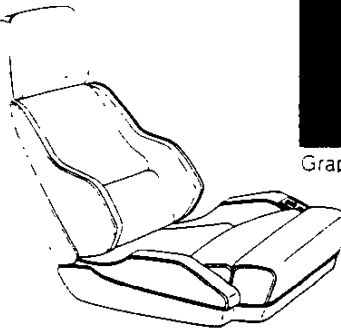

Graphite



Gray



Blue



Bronze

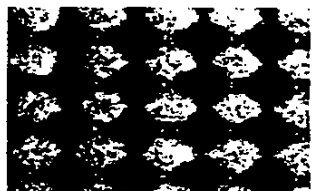

Saddle

\*Interim availability. Includes driver- and passenger-side power adjustment for lateral and lumbar support, plus back angle. Manual thigh support. Wool-pad comfort liner included with all standard and optional seats.

Refer to Dealer Order Guide for option availability and application.

# Exterior Colors

10 - White



16 - Silver (Metallic)



18 - Gray (Metallic)



19 - Black

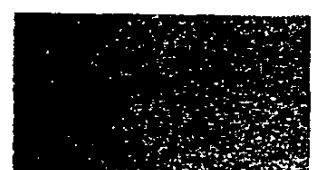

20 - Light Blue (Metallic)

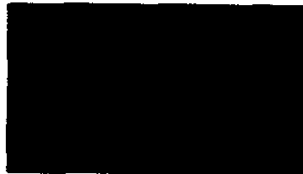

23 - Medium Blue (Metallic)



53 - Gold (Metallic)



63 - Light Bronze (Metallic)



66 - Dark Bronze (Metallic)

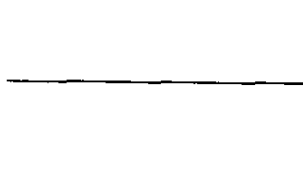

70 - Red



## Custom Two-Tone (RPO D84)



Silver (Metallic);  
Gray (Metallic) Accent



Light Blue (Metallic);  
Medium Blue (Metallic) Accent



Light Bronze (Metallic);  
Dark Bronze (Metallic) Accent

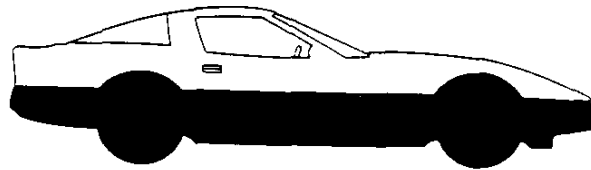

Refer to Dealer Order Guide for option availability and application.

## Wheel Trim

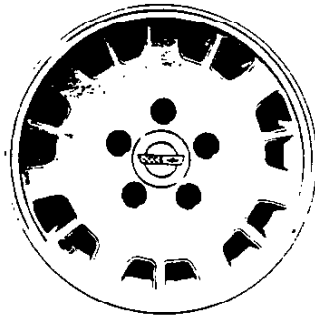

Standard 15" cast aluminum wheels with 7"-wide rims in front; 7½" in rear. P215/65R-15 Eagle GT blackwall tires.

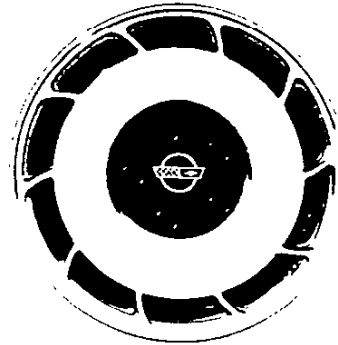

Available 16" cast aluminum wheels with 8½"-wide rims and P255/50VR-16 Eagle GT blackwall tires. With Performance Handling Package (RPO Z51), front wheels are 8½"-wide, 9½"-wide in rear and have same P255/50VR-16 Eagle GT blackwall tires.

## Steering Wheel

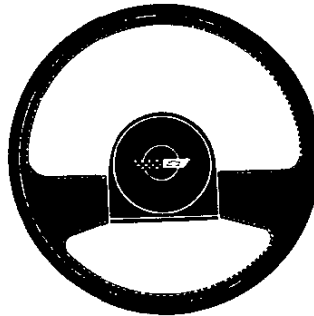

Standard black, leather-wrapped rim and spokes with leather-trimmed, padded horn button. Corvette emblem in horn button.

All illustrations and specifications in this brochure are based on the latest product information available at the time of publication approval. Right is reserved to make changes at any time, without notice, in colors, materials, specifications and models, and also to discontinue models. Chevrolet Motor Division, General Motors Corporation, Warren, Michigan 48090.

 Chevrolet

Litho in U.S.A. 4270 11.82

Refer to Dealer Order Guide for option availability and application.



---

---

## ✓ ALPHABETICAL OPTION INDEX

(Not for ordering purposes)

Option Number	Description	Option Number	Description
AG9	SEAT, POWER: Six-Way	UL5	RADIO EQUIPMENT: Radio Delete
AU3	DOOR LOCK SYSTEM, POWER	UM6	RADIO EQUIPMENT: Electronically Tuned AM/FM Stereo Radio w/Seek-Scan and Cassette Tape and Clock
B3W	PRELIMINARY PRICE INFORMATION	UU8	RADIO EQUIPMENT: Delco-GM/Bose Music System-Electronically Tuned AM/FM Stereo Radio w/Seek-Scan and Cassette Tape and Clock
CC3	ROOF PANEL: Transparent Lift-Off	V01	RADIATOR, HEAVY-DUTY
D60	NON-RECOMMENDED COLOR COMBINATION	YF5	EMISSION SYSTEM: California Emission Requirements
D84	PAINT: Custom Two-Tone	Z51	PERFORMANCE HANDLING PACKAGE
FG3	SHOCK ABSORBERS: Delco/Bilstein	Z6A	DEFOGGER SYSTEM: Rear Window and Outside Rearview Mirrors
KC4	COOLER, ENGINE OIL	18M	ACCENT COLOR: Gray Metallic
K34	SPEED CONTROL, ELECTRONIC: With Resume Speed	23M	ACCENT COLOR: Med Blue Metallic
L83	ENGINE: 5.7 Liter Dual C.F.I. V8	66M	ACCENT COLOR: Dk Bronze Metallic
MM4	TRANSMISSION WITH OVERDRIVE: 4-Speed Manual		
MX0	TRANSMISSION WITH OVERDRIVE: Automatic		
NA5	EMISSION SYSTEM: Standard Emission Equipment		

# CORVETTE

## COLOR AND TRIM SELECTION

PLEASE NOTE: The Exterior and Interior Combinations shown in the charts below and designated as recommended (R), represent the ideal combinations. Those that are shown as acceptable (A), are attractive, but less desirable than the recommended combinations.

Interior Trim	Color	Blue	Bronze	Graphite	Gray	Dk Red	Saddle
MODEL	SEAT TYPE						
1YY07	Leather Bucket		AEE2	ABB2	AQQ2	ARR2	AUU2
	Cloth Bucket	HDD2	HEE2	HBB2	HQQ2		HUU2
	Cloth Adjustable Sport Bucket	BDD8	BEE8	BBB8	BQQ8		BUU8

### WITH D84 CUSTOM TWO-TONE PAINT (Accent Color Must be Specified)

(D60 NON-RECOMMENDED COLOR COMBINATION NOT PERMITTED)

Exterior Paint Color	Color Code L	Color Code U	Accent Color and Ordering Code #	Blue	Bronze	Graphite	Gray	Dk Red	Saddle
Blue, Light (Met)	20	20	Med Blue (Met) 23M	R					
Bronze, Light (Met)	63	63	Dk Bronze (Met) 66M		R				
Silver (Met)	16	16	Gray (Met) 18M			R	R	A	

≠ Must be Ordered

### WITHOUT D84 CUSTOM TWO-TONE PAINT

PLEASE NOTE: Orders for additional Interior Trim combinations may be submitted, provided the dealer orders (D60), as verification that the requested combination is definitely desired.

Black	41	41			A	R	R	R	R
Blue, Corvette Light (Mt)	20	20		R		A			
Blue, Corvette Med (Met)	23	23		R		A			
Bronze, Corvette Dark (Mt)	66	66			R				
Bronze, Corvette Lt (Mt)	63	63			R				
Gold, Corvette (Met)	53	53				A			R
Gray, Corvette (Met)	18	18				R	R	A	
Red, Corvette	33	33				R		R	R
Silver, Corvette (Met)	16	16				R	R	A	
White, Corvette	40	40		R	A	R	R	R	R

L = Lower U = Upper

### POWER TEAMS (Refer to next page for option availability and application)

ENGINE OPTION CONDITION	AXLE RATIO
	3.07
<b>WITH NA5 STANDARD EMISSIONS</b>	
L83	Std
<b>WITH YF5 CALIFORNIA EMISSIONS</b>	
L83	Std

# CORVETTE

REFER WEEKLY STOPS/LATEST UPDATE

MODEL  
1YY07 Corvette 2-Door Hatchback Coupe

ENGINE: MUST ORDER (See Power Teams)

STANDARD EMISSION EQUIPMENT—REQUIRES NA5 (Also Satisfies High Altitude Requirements)  
\_\_\_\_\_ L83 5.7 Liter Dual C.F.I. V8

CALIFORNIA EMISSION EQUIPMENT—REQUIRES YF5  
\_\_\_\_\_ L83 5.7 Liter Dual C.F.I. V8

EMISSION SYSTEMS: MUST ORDER ONE (See Above)

\_\_\_\_\_ NA5 STANDARD EMISSION EQUIPMENT

\_\_\_\_\_ YF5 CALIFORNIA EMISSION REQUIREMENTS

## QUICK-SPEC

IF TRANSMISSION  
IN QUICK-SPEC IS NOT DESIRED  
YOU MUST "PLUS" ANOTHER  
TRANSMISSION OPTION.

		C	C
		V	V
		A	A
		1	2
Door Lock System, Power	AU3	x	x
Radio, Electronically Tuned AM/FM			
Stereo w/Cassette Tape	UM6	x	N/I
Seat, Power	AG9	x	x
Speed Control with Resume Speed	K34	x	x
Transmission, Automatic w/Overdrive	MX0	x	x
Defogger System	Z6A		x
Radio, AM/FM Stereo w/Cassette Tape (Delco/Bose Sound System)	UU8		x

## PLEASE REVIEW OPTION RESTRICTIONS BEFORE ORDERING

Q-S	OPTION
—	KC4 COOLER, ENGINE OIL: (Reqs Z51 Performance Handling Package)
(2)	Z6A DEFOGGER SYSTEM: Rear Window and Outside Rearview Mirrors
(1)	AU3 DOOR LOCK SYSTEM, POWER
—	O84 PAINT, CUSTOM TWO-TONE
—	Z51 PERFORMANCE HANDLING PACKAGE: (Incls Special Suspension)
—	B3W PRELIMINARY PRICE INFORMATION
—	V01 RADIATOR, HEAVY-DUTY
✓	RADIO EQUIPMENT:
(1)	UM6 — Electronically Tuned AM/FM Stereo Radio w/Seek-Scan and Cassette Tape and Clock
(2)	UU8 — Delco-GM/Bose Music System—Electronically Tuned AM/FM Stereo Radio w/Seek-Scan and Cassette Tape and Clock
—	UL5 — Radio Delete
—	CC3 ROOF PANEL: Transparent Lift-Off
(1)	AG9 SEAT, POWER: Six-Way (Driver's side only)
—	FG3 SHOCK ABSORBERS: Delco/Bilstein (Reqs Z51 Performance Handling Package)
(1)	K34 SPEED CONTROL, ELECTRONIC: With Resume Speed
—	TRANSMISSIONS: (See Power Teams Chart)
—	MM4 — 4-Speed Manual with Overdrive
(1)	MX0 — Automatic Transmission with Overdrive

**NOTES**



# MOTOR VEHICLE

## Specifications

METRIC (U.S. Customary)

### Passenger Car

# 1984

<b>Manufacturer</b> CHEVROLET MOTOR DIVISION GENERAL MOTORS CORPORATION	<b>Car Line</b>  CORVETTE	
<b>Mailing Address</b> CHEVROLET ENGINEERING CENTER 30003 VAN DYKE WARREN, MI 48090	<b>Issued</b> JANUARY 10, 1983	<b>Revised</b> APRIL, 1983

Questions concerning these specifications should be directed to the manufacturer whose address is shown above.

The information contained herein is prepared, distributed by, and is solely the responsibility of the automobile manufacturing company to whose products it relates. This specification form was developed by the automobile manufacturing companies under the auspices of the Motor Vehicle Manufacturers Association of the United States, Inc.

The General Specifications herein are those in effect at date of compilation and are subject to change without notice by the manufacturer.

# MVMA Specifications Form Passenger Car

METRIC (U.S. Customary)

## Table of Contents

---

1	Car Models
2	Power Teams
3-6	Engine
4	Lubrication System
4	Diesel Information
5	Cooling System
6	Fuel System
7	Vehicle Emission Control
7	Exhaust System
8-10	Transmission, Axles and Shafts
11	Suspension-Front and Rear
12-13	Brakes
13	Tires and Wheels
14-15	Steering
15-16	Electrical
17	Body — Miscellaneous Information
17	Glass
17	Frame
18	Passive Restraint System
19	Convenience Equipment
20-22	Car and Body Dimensions
23	Vehicle Fiducial Marks
24	Lamps and Headlamps
25	Vehicle Mass (Weight)
26	Optional Equipment Mass (Weight)
27-31	Car and Body Dimension Key Sheets
32	Index
	Supplemental Page
	Feature Highlights Page

---

### NOTE:

1. This form uses both SI metric units and U.S. Customary units. The metric unit of measure is presented first, and the U.S. Customary unit follows in parentheses.
2. UNLESS OTHERWISE INDICATED:
  - a. Specifications apply to standard models without optional equipment. Significant deviations are noted.
  - b. Nominal design dimensions are used throughout these specifications.
  - c. All linear dimensions are in millimeters (inches), and all mass (weight) specifications are in kilograms (pounds).
3. The General Specifications herein are those in effect at date of completion and are subject to change without notice by the manufacturer.
4. Additional Car and Body Dimensions and/or drawings (based in part on SAE J1100a "Motor Vehicle Dimensions") may be available from the manufacturer.

**MVMA Specifications Form**  
**Passenger Car**  
**METRIC (U.S. Customary)**

Car Line CORVETTE  
 Model Year 1984 Issued 1-10-83 Revised (\*) 4-83

**Car Models**

Model Description FWD/RWD	Introduction Date	Make, Car Line, Series, Body Type (Mfr's Model Code)	No. of Designated Seating Positions (Front/Rear)	Max. Trunk/Cargo Load—Kilograms (Pounds)
CORVETTE		MODEL NUMBER	FRONT	
2-Door Hatchback Coupe		1YY07	2	45.4 (100)

NOTE: Any specifications on the following pages specific to California requirements are indicated accordingly.



**MVMA Specifications Form**  
**Passenger Car**  
**METRIC (U.S. Customary)**

Car Line CORVETTE  
 Model Year 1984 Issued 1-10-83 Revised (\*) 4-83

**Power Teams** (Indicate whether standard or optional) -

SAE J1349 Net bhp (brake horsepower) and net torque connected to 77° F/25° C and 29.61 in. Hg/100 Kpa atmospheric pressure.

SERIES AVAILABILITY	ENGINE					E X H A U S T S/D	TRANSMISSION TRANSAXLE	AXLE RATIO (std first) Base/Opt.
	Displ. Liters (in <sup>3</sup> )	Carb. (Barrels, Fl. etc.)	Compr Ratio	SAE Net at RPM				
				kW (bhp)	Torque N - m (lb ft)			
Base-All States	V8 5.7 Liter (350 CID) L83	CFI @	9.0:1	(205@ 4300)	(290@ 2800)	D	*Man. 4-Spd. (2.88 low) - Avail.  Auto '700-R4' - Base	3.07:1/3.31:1
@ - Cross-Fire Injection * - Automatic Overdrive 2nd, 3rd, 4th gears								

**MVMA Specifications Form**  
**Passenger Car**  
**METRIC (U.S. Customary)**

Car Line CORVETTE  
 Model Year 1984 Issued 1-10-83 Revised (\*) 4-83

Engine Description/Carb.  
 Engine Code

5.7 Liter V8 (350 CID)  
 Cross-Fire Injection (CFI)  
 RPO L83

**ENGINE - GENERAL**

Type & description (inline V, angle, flat, location, front, mid, rear, transverse, longitudinal, sonic, donc, ohv, hemi, wedge, pre-camber, etc.)	90° "V" Front Longitudinal	
No. of cylinders	8	
Bore	101.6 (4.00)	
Stroke	88.4 (3.48)	
Bore spacing (c'1 to c'1)	111.8 (4.40)	
Cylinder block material	Cast alloy iron	
Cylinder block deck height	229.2 (9.025)	
Deck clearance (minimum) (above or below block)	.025 below	
Cylinder head material	Cast alloy iron	
Cylinder head volume (cm <sup>3</sup> )		
Head gasket thickness (compressed)	.021	
Minimum combustion chamber total volume (cm <sup>3</sup> )	75.47 (+)	
Cyl. no. system (front to rear)*	L Bank	1-3-5-7
	R Bank	2-4-6-8
Firing order	1-8-4-3-6-5-7-2	
Recommended fuel (leaded unleaded diesel)	Unleaded	
Fuel antiknock index (R + M) / 2	87	
Total dressed engine mass (wtl dry)**	268.0 (590.9) Man. Trans., 263.6 (281.2) Auto. Trans.	

**Engine - Pistons**

Material & mass, g (weight oz) piston	Impacted forged aluminum, 579 (20.4)
---------------------------------------	--------------------------------------

**Engine - Camshaft**

Location	In cylinder block "V" above crankshaft	
Material (kg weight lbs)	Cast alloy iron, 3.871 (8.53)	
Drive type	Chain/belt	Chain
	Width/pitch	15.87 (.625)/12.70 (.500)

\* Rear of engine - drive takeoff! View from drive takeoff end to determine left & right side of engine

\*\* Dressed engine mass (weight) includes the following

The additional engine items that are required to make the engine an independent working power unit. This does not include radiator hoses, coolant, accelerator controls and engine mounting.

(+) - Combustion chamber with piston at top dead center and all components in place torqued to specifications.

**MVMA Specifications Form**  
**Passenger Car**  
**METRIC (U.S. Customary)**

Car Line CORVETTE  
 Model Year 1984 Issued 1-10-83 Revised (\*) 4-83

Engine Description/Carb.  
 Engine Code

5.7 Liter V8 (350 CID)  
 Cross-Fire Injection (CFI)  
 RPO L83

**Engine - Valve System**

Lifters (std., opt., n.a.)	Hydraulic	Standard
	Solid	--

**Engine - Connecting Rods**

Material & mass (kg., weight, lbs.)	1037 or 1038 steel - .388 (0.855)
-------------------------------------	-----------------------------------

**Engine - Crankshaft**

Material	Nodular cast iron
Mass (kg., weight, lbs.)	23.520 (51.85)
End thrust taken by bearing (no.)	5

**Engine - Lubrication System**

Normal oil pressure (kPa (psi) at engine rpm)	345-450 (50-65) @ 2000
Type oil intake (floating stationary)	Stationary
Oil filter system (full flow, part other)	Full flow
Capacity of c/case less filter-refill-L (qt)	3.8 (4.0)

**Engine - Diesel Information**

Glow plug, current drain at 0°F	Not	
Injector nozzle	Type	Applicable
	Opening pressure (kPa (psi))	--
Pre-chamber design	--	
Fuel injection pump	Manufacturer	--
	Type	--
Supplementary vacuum source (type)	--	
Fuel heater (yes/no)	--	
Water separator, description (std., opt.)	--	
Turbo manufacturer	--	
Oil cooler	--	
Oil filter	--	

**MVMA Specifications Form**  
**Passenger Car**  
**METRIC (U.S. Customary)**

Car Line CORVETTE  
 Model Year 1984 Issued 1-10-83 Revised (\*) 4-83

Engine Description/Carb.  
 Engine Code

5.7 Liter V8 (350 CID)  
 Cross-Fire Injection (CFI)  
 RPO 183

**Engine - Cooling System**

Coolant recovery system (std., opt., n.a.)		Standard
Coolant fill location (rad., bottle)		Bottle, coolant recovery
Radiator cap relief valve pressure (kPa (psi))		103.4 (15.0)
Circulation thermostat	Type (choke, bypass)	Choke
	Starts to open at °C (°F)	90.6 (195°)
Water pump	Type (centrifugal, other)	Centrifugal with cast aluminum housing
	GPM 1000 pump rpm	13
	Number of pumps	One
	Drive (V-belt, other)	Single belt poly 'V' accessory drive (serpentine)*
	Bearing (type)	Sealed double row ball
By-pass recirculation (type (inter. ext.))		Internal
Radiator core (type (cross-flow vertical cellular tube and fin, other) and material)		Cross-Flow; alum. header, tubes and fins, plastic tanks
Cooling system capacity	With heater - L/qt.	--
	With air cond - L/qt.	Manual 13.86 (14.65), Automatic 13.73 (14.51)
	Opt. equipment (specify - L/qt.)	--
Water jackets full length of cyl. (yes, no)		Yes
Water all around cylinder (yes, no)		Yes
Radiator core	Std. A/C. HD	A/C, Standard
	Width	599.5 (23.6)
	Height	382.4 (15.0)
	Thickness	23.5 (0.9)
	Fins per inch	2.5
Std. elec. opt.		Electric, Standard
Fan	Number of blades & type (flex, solid, material)	5-blades, high efficiency curved blades and ring shroud, plastic
	Diameter & projected width	418.0 (16.5)
	Ratio (fan to crankshaft rev.)	--
	Fan cutout type	Temp. switch
	Drive (type (direct, remote))	Electric
	RPM at idle (elec.)	2100
	Motor rating (wattage) (elec.)	150 wattage
	Motor switch (type & location) (elec.)	Temp. switch
	Switch point (temp., pressure) (elec.)	106°C
Fan shroud (material)		Plastic-ring shroud

\* - 21.36 mm (0.84") wide, 5.20 mm (0.20") thick, with uniform dynamic tensioner.

**MVMA Specifications Form**  
**Passenger Car**  
**METRIC (U.S. Customary)**

Car Line CORVETTE  
 Model Year 1984 Issued 1-10-83 Revised (\*) 4-83

Engine Description/Carb.  
 Engine Code

5.7 Liter V8 (350 CID)  
 Cross-Fire Injection (CFI)  
 RPO L83

**Engine - Fuel System** (See supplemental page for details of Fuel injection Supercharger, Turbocharger, etc if used)

Induction type: carburetor, fuel injection system, etc.		Electronic fuel injection (dual throttle body injectors)
Carburetor	Mfg.	
	Choke (type)	
	Idle spd -rpm (spec neutral or drive and propane if used)	Manual Automatic
Idle A/F mix		14.7:1 (Stoichiometric)
Fuel injection	Point of injection (no)	At throttle body - single point
	Constant pulse flow	Pulse
	Control (electronic, mech.)	Electronic - on board computer
	System pressure (kPa (psi))	75.8 (11.0)
Intake manifold heat control (exhaust or water) thermostatic or fixed		Water, thermostat
Air cleaner type	Standard	Replaceable paper element, dual snorkel
	Optional	--
Fuel pump	Type (elec or mech)	Electric - dual turbine
	Location (eng. tank)	In fuel tank
	Pressure range (kPa (psi))	Approximately (11 psi)

**Fuel Tank**

Capacity (refill L (gallons))		75.7 (20.0)
Location (describe)		Under rear deck
Attachment		Rests on rear frame extension, held with straps
Material		Super Terne coated steel with high density polyethylene liner
Filler Pipe	Location & material	Center of rear deck
	Connection to tank	Bolted with gasket on top of tank
Fuel line (material)		Super Terne coated steel
Fuel hose (material)		Viton
Return line (material)		Super Terne coated steel
Vapor line (material)		Super Terne coated steel
Extended range tank	Opt n/a	Not available
	Capacity (L (gallons))	--
	Location & material	--
	Attachment	--
Auxiliary tank	Opt n/a	Not available
	Capacity (L (gallons))	--
	Location & material	--
	Attachment	--
	Selector switch or valve	--
Separate fill		--

**MVMA Specifications Form**  
**Passenger Car**  
**METRIC (U.S. Customary)**

Car Line CORVETTE  
 Model Year 1984 Issued 1-10-83 Revised (\*) 4-83

Engine Description/Carb.  
 Engine Code

5.7 Liter V8 (350 CID)  
 Cross-Fire Injection (CFI)  
 RPO 183

**Vehicle Emission Control**

Exhaust Emission Control	Type (air injection, engine modifications other)		Air injection w/Computer Command Control	
	Air Injection	Pump or pulse	Vane	
		Driven by	Serpentine - single belt poly 'V' drive	
		Air distribution (head manifold, etc)	Exhaust manifold and converter (CCC controlled)	
		Point of entry	Exhaust manifold ports	
	Exhaust Gas Recirculation	Type (controlled flow, open orifice, other)	Controlled flow	
		Exhaust source	Inlet manifold exhaust cross-over passage	
		Point of exhaust injection (spacer carburetor manifold other)	Center of inlet manifold plenum	
	Catalytic Converter	Type	Platinum-Palladium, and Rhodium, dual-bed	
		Number of	One	
		Location(s)	Underbody tunnel below console	
		Volume (L (in <sup>3</sup> ))	2.7822 (169.8)	
	Crankcase Emission Control	Substrate type		Monolith
		Type (ventilates to atmosphere, induction system other)		Induction system
Energy source (manifold vacuum, carburetor other)		Manifold vacuum		
Discharges (to intake manifold, other)		Inlet manifold		
Air inlet (breather, sp, other)		Air cleaner		
Evaporative Emission Control	Vapor vented to (crankcase canister, other)	Fuel tank	Canister	
		Carburetor	--	
	Vapor storage provision		Canister	
Electronic system	Closed loop (yes/no)		Yes	
	Open loop (yes/no)		No	

**Engine - Exhaust System**

Type (single, single with cross-over, dual, other)		Dual
Muffler no & type (reverse flow, straight thru, separate resonator)		Two, reverse flow (Stainless steel body, aluminum coated steel inlet and outlets)
Resonator no. & type		None
Exhaust pipe	Branch od, wall thickness	Otr pipe 63.5x.96(2.50x.038), inr pipe 57.0x.96(2.25x.038)
	Main od, wall thickness	76.2 x 1.83 (3.0 x .072)
	Material	Stainless steel tubing (*)
Inter-mediate pipe	od & wall thickness	57.15 x 1.83 (2.25 x .072)
	Material	Aluminum coated steel
Tail pipe	od & wall thickness	Dual outlets - 57.15 x 1.83 (2.25 x .072)
	Material	Aluminum coated steel

(\*) - 2.29 (.09) air gap between pipes for heat control and sound dampening.

**MVMA Specifications Form**  
**Passenger Car**  
**METRIC (U.S. Customary)**

Car Line CORVETTE  
 Model Year 1984 Issued 1-10-83 Revised (\*) 4-83

Engine Description/Carb.  
 Engine Code

5.7 Liter V8 (350 CID)  
 Cross-Fire Injection (CFI)  
 RPO 183

**Transmissions/Transaxle**

Manual 3-speed (std., opt., n.a.)	Not available
Manual 4-speed (std., opt., n.a.)	Available
Manual 5-speed (std., opt., n.a.)	Not available
Manual overdrive (std., opt., n.a.)	Not available
Automatic (std., opt., n.a.)	Not available
Automatic overdrive (std., opt., n.a.)	Standard

**Manual Transmission/Transaxle**

Number of forward speeds		4 in direct drive, 3 in overdrive*	
Transmission ratios	In first	2.88	
	In second	1.91 direct; 1.28 overdrive	
	In third	1.33 direct; 0.89 overdrive	
	In fourth	1.00 direct; 0.67 overdrive	
	In fifth	--	
	In overdrive	0.67	
	In reverse	2.78	
Synchronous meshing (specify gears)		All Forward	
Shift lever location		Floor	
Lubricant	Capacity (L (qt))	1.0L (2.1), (1.63L (3.45) for overdrive unit)	
	Type recommended	GL-5 (Dextron II for overdrive unit)	
	SAE viscosity number	Summer	SAE -80W, SAE -80W-90
		Winter	SAE -80W, SAE -80W-90
	Extreme cold	SAE -80W	

**Clutch (Manual Transmission)**

Make & type		Borg & Beck, hydraulically activated slave cylinder; automatic adjustment.
Type pressure plate springs		Bellville
Total spring load (N (lb))		10230 (2300)
No. of clutch driven discs		One
Clutch facing	Material	Woven molded asbestos
	Manufacturer	Borg & Beck
	Part number	14055162
	Rivets/plate	40
	Rivet size	5.41 x 3.63 (.213 x .143)
	Outside & inside dia	266.7 x 165.1 (10.50 x 6.5)
	Total eff. area (cm <sup>2</sup> (in <sup>2</sup> ))	344.5 (53.4)
	Thickness	7.7 (.305)
Engagement cushion method		Driven plate wave spoke springs
Release bearing	Type & method of lubrication	Ball thrust - prepacked and sealed
Torsional damping	Method springs, friction material	Coil springs and metal-to-metal friction

\* - Planetary gear set overdrive controlled by on-board computer.

**MVMA Specifications Form**  
**Passenger Car**  
**METRIC (U.S. Customary)**

Car Line CORVETTE  
 Model Year 1984 Issued 1-10-83 Revised (\*) 4-83

Engine Description/Carb.  
 Engine Code

5.7 Liter V8 (350 CID)  
 Cross-Fire Injection (CFI)  
 RPO L83

**Automatic Transmission/Transaxle**

Trade name		4-Speed Automatic (overdrive 4th gear)
Type and special features (describe)		Torque converter with planetary gears
Selector	Location	Floor mounted in console
	Ltr/No designation	PRN(D) D21
Gear ratios	R	2.29
	4	0.70@
	3	1.00@
	2	1.63
	1	3.06@
Max upshift speed - drive range (km/h (mph))		1-2=41 MPH, 2-3=75 MPH, 3-4=110 MPH (at wide open throttle)
Max kickdown speed - drive range (km/h (mph))		4-3=100 MPH, 3-2=68 MPH, 2-1=33 MPH
Min overdrive speed (km/h (mph))		41 MPH
Torque converter	Number of elements	3
	Max ratio at stall	1.85
	Type of cooling (air, liquid)	Liquid
	Nominal diameter	298 (11.75)
Lubricant	Capacity (refill L (pt))	3.8 (8.0)
	Type recommended	Dexron II
Oil cooler (std., opt., NA, internal, external, air, liquid)		Standard, external, liquid

@ - Computer controlled torque converter clutch 2nd, 3rd and 4th gears.

**Axle or Front Wheel Drive Unit**

Type (front, rear)		Rear	
Description		Overhung pinion gear	
Limited slip differential (type)		Standard - disc clutches	
Drive pinion offset		38.1 (1.50)	
Drive pinion (type)		Hypoid	
No. of differential pinions		Two	
Pinion adjustment (shim, other)		None	
Pinion bearing adj. (shim, other)		Shim	
Driving wheel bearing (type)		Tapered roller	
Lubricant	Capacity (L (pt))	1.8 (3.75)	
	Type recommended	GL-5 Gear Lubricant	
	SAE viscosity number	Summer	80W or 80W-90
		Winter	80W or 80W-90
		Extreme cold	80W or 80W-90

**Axle or Transaxle Ratio and Tooth Combinations (See "Power Teams" for axle ratio usage)**

Axle ratio (or overall top gear ratio)		3.07:1	3.31:1
No. of teeth	Pinion	14	13
	Ring gear or gear	43	43
Ring gear od		200 mm (7-7/8")	200 mm (7-7/8")
Transaxle	Transfer gear ratio	--	--
	Final drive ratio	--	--



**MVMA Specifications Form**  
**Passenger Car**  
**METRIC (U.S. Customary)**

Car Line CORVETTE  
 Model Year 1984 Issued 1-10-83 Revised (\*) 4-83

Engine Description/Carb.  
 Engine Code

5.7 Liter V8 (350 CID)  
 Cross-Fire Injection (CFI)  
 RPO 183

**Propeller Shaft — Conventional Drive**

Type (straight tube, tube-in-tube, internal-external damper, etc.)		Straight Tube, internal-external damper	
Outer diam x length* x wall thickness	Manual 3-speed trans	Not available	
	Manual 4-speed trans with auto overdr	Aluminum 76.2 x 859.3 x 3.05 (3.00 x 33.83 x 0.12)	
	Manual 5-speed trans	Not available	
	Overdrive	See manual 4-speed	
	Automatic transmission	Steel W/O Power Seat 63.5 x 859.3 x 1.65 (2.50 x 33.83 x .065)	Alum. W/Power Seat And/Or Handling 76.2 x 859.3 x 3.05 (3.00 x 33.83 x 0.12)
Inter-mediate bearing	Type (plain, anti-friction)	None	
	Lubrication (fitting, prepack)	--	
Slip yoke	Type	Splined Yoke	
	Number of teeth	Automatic and manual transmissions - 26	
	Spline od	Automatic and manual transmissions 29.7 (1.17)	
Universal joints	Make and mfg no	Front	#1311
		Rear	#1318
	Number used	Two	
	Type (ball and trunnion, cross)	Cross	
	Rear attach (u-bolt, clamp, etc.)	Strap and Bolt	
	Bearing	Type (plain, anti-friction)	Anti-Friction
Lubric. (fitting, prepack)		Prepack	
Drive taken through (torque tube, arms or springs)		Torque control arms	
Torque taken through (torque tube, arms or springs)		Torque control arms	

\* Centerline to centerline of universal joints, or to centerline of rear attachment

**MVMA Specifications Form**  
**Passenger Car**  
**METRIC (U.S. Customary)**

Car Line CORVETTE  
 Model Year 1984 (issued 1-10-83 Revised (\*) 4-83)

Body Type And/Or  
 Engine Displacement

2-Door  
 Hatchback Coupe  
 1YY07

**Suspension - General**

Car leveling	Std./opt./n.a.	Not available
	Type (air, hyd, etc.)	--
	Manual/auto controlled	--
Provision for brake dip control		Frt susp geometry-upper arms pos. to produce 46% anti-dive
Provision for accel equal control		Rr susp geometry-control arms pos to produce 51% anti-squat
Special provisions for car jacking		Place jack head between locator triangles on rocker flange nearest to wheel being changed.
Shock absorber (front & rear)	Type	Direct double acting hydraulic w/pliaclell expansion bags
	Make	Delco
	Piston diameter	25.4 (1.0)
	Rod diameter	13.49 (0.53)

**Suspension - Front**

Type and description		SLA forged al. str knuckle, upr and lwr cont. arms and cold formed cross shafts. Transverse filament wound glass-epoxy composite single leaf spring.
Travel	Full jounce	83.0 mm
	Full rebound	86.5 mm
Spring	Type (coil leaf other)	Transverse leaf (dual pivot)
	Material	Filament wound glass-epoxy composite
	Size (coil design height & i.d. bar length x dia)	1171.0 x 100.0 x 15.1 base, 17.1-251 (46.1 x 3.9 x 0.6 base, 0.7-251)
	Spring rate (N/mm (lb/in))	Base 75.4 (431.0), 251-110.9 (634.0)
Rate at wheel (N/mm (lb/in))		Base 26.0 (148.0), 251-33.8 (193.0)
Stabilizer	Type (link linkless frameless)	Link
	Material & bar diameter	HR steel; 24 mm (0.9 in.) dia. base, 25 mm (1.0 in.) 251

**Suspension - Rear**

Type and description		5-link fully indep; forged al. upper and lower control arms, lower transverse tie rod and rear knuckles. Tubular "U" jointed drive shafts. Transverse filament wound glass-epoxy composite leaf spring.
Drive and torque taken through		Upper and lower longitudinal control arms
Travel	Full jounce	86.0 mm (3.4 in)
	Full rebound	84.0 mm (3.3 in)
Spring	Type (coil leaf other)	Monoleaf
	Material	Filament wound glass-epoxy composite
	Size (length x width coil design height & i.d. bar length & dia)	1236 x 57.9 x 27.1 (48.7 x 2.28 x 1.07)
	Spring rate (N/mm (lb/in))	Base 75.5 (431.0), 251-91.8 (525.0)
Rate at wheel (N/mm (lb/in))		Base 38.4 (219.0), 251-45.9 (262.0)
Mounting insulation (type)		Dual rubber polyisoprene
Stabilizer	Type (link linkless frameless)	Link
	Material & bar diameter	HR steel; 20.0 (0.79); painted to protect against corrosion
Track bar (type)		None

**MVMA Specifications Form**  
**Passenger Car**  
**METRIC (U.S. Customary)**

Car Line CORVETTE  
 Model Year 1984 Issued 1-10-83 Revised (r. 4-83)

Body Type And/Or  
 Engine Displacement

2-DOOR  
 HATCHBACK COUPE  
 1YY07

**Brakes - Service**

Description		Aluminum caliper with nodular iron reaction bracket; pad reaction thru bracket.			
Brake type (std., opt. n.a.)	Front (disc or drum)	Disc with sliding-head caliper, low drag			
	Rear (disc or drum)	Disc with sliding-head caliper, low drag			
Self-adjusting (std., opt., n.a.)		Standard			
Special valving	Type (proportion, delay, metering, other)	Proportioning, Integral with Master Cylinder			
Power brake (std., opt., n.a.)		Standard			
Booster type (remote, integral, vac. hyd., etc.)		Integral; lightweight with tru-bolt reaction system			
Vacuum source (inline, pump, etc.)		Inline (Intake Manifold)			
Vacuum reservoir (volume in <sup>3</sup> )		--			
Vacuum pump-type (elec., gear driven, belt driven, if other so state)		--			
Anti-skid device type (std., opt., n.a.) (F/R)		Not Available			
Effective area (cm <sup>2</sup> (in <sup>2</sup> ))*		322 (50.0)			
Gross lining area (cm <sup>2</sup> (in <sup>2</sup> )** (F/R)		300.4 (46.6)			
Swept area (cm <sup>2</sup> (in <sup>2</sup> ))*** (F/R)		2128 (329.9)			
Rotor	Outer working diameter	F/R	292 (11.5)/292 (11.5)		
	Inner working diameter	F/R	204 (8.0)/215 (8.5)		
	Thickness	F/R	20 (0.8)/20 (0.8)		
	Material & type (vented/solid)	F/R	Gray Cast Iron - Vented		
Drum	Diameter (nominal)	F/R	Not Applicable		
	Type and material	F/R	Not Applicable		
Wheel cylinder bore		54 (2.1)/40.5 (1.6)			
Master cylinder	Bore/stroke	F/R	20.6 (0.8)/13.8 (0.5) Primary, 19.0 (0.7) (Secondary)		
Pedal arc ratio		3.5:1			
Line pressure at 445 N (100 lb.) pedal load (kPa (psi))		9000 (1305) Front, 4600 (667) Rear			
Lining clearance per shoe		F/R	Self Adjusting		
Brake lining	Front wheel	Bonded or riveted (rivets/seg)		Integral Molded	
		Rivet size		None	
		Manufacturer		Japan Brake Industries	
		Lining code		JBH3H	
		Material		Semi-Metallic	
		****	Primary or out-board	44.2 (6.8) Pad Area	
		Size	Secondary or in-board	44.2 (6.8) Pad Area	
	Shoe thickness (no lining)		5.0 mm (0.2) Backing Plate		
	Rear wheel	Bonded or riveted (rivets/seg)		Integral Molded	
		Manufacturer		Japan Brake Industries	
		Lining code		JBH3H	
		Material		Semi-metallic	
		****	Primary or out-board	30.9 (4.8) Pad Area	
		Size	Secondary or in-board	30.9 (4.8) Pad Area	
Shoe thickness (no lining)		5.0 mm (0.2) Backing Plate			

\* Excludes rivet holes, grooves, chamfers, etc.

\*\* includes rivet holes, grooves, chamfers, etc.

\*\*\* Total swept area for four brakes (Drum brake: Widest lining contact width for each brake x its contact circumference) (Disc brake: Square of Outer Work ing Dia. minus Square of Inner Working Dia. multiplied by Pi/2 for each brake)

\*\*\*\* Size for drum brakes includes length x thickness

**MVMA Specifications Form**  
**Passenger Car**  
**METRIC (U.S. Customary)**

Car Line CORVETTE  
 Model Year 1984 Issued 1-10-83 Revised (\*) 4-83

Body Type And/Or  
 Engine Displacement

2.-Door  
 Hatchback Coupe  
 1YY07

**Tires And Wheels (Standard)**

Tires	Size (load range, ply)		P215/65R-15 B/W
	Type (bias, radial, etc)		Steel belted radial Eagle GT (Goodyear)
	Inflation pressure (cold) for recommended max vehicle load	Front (kPa (psi))	240 (35)
		Rear (kPa (psi))	240 (35)
	Rev/mile—at 70 km/h (45 mph)		472 (760)
Wheels	Type & material		Cast alloy road wheels
	Rim (size & flange type)		Front 15 x 7, Rear 15 x 7-1/2
	Wheel offset		17 mm frt, 25 mm rr
	Attachment	Type (bolt or stud)	Stud
		Circle diameter	120.7 (4.75)
Number & size		5 Hex nuts, M12x1.5-6H (one anti-theft for opt 16-inch wheels)	
Spare	Tire and wheel (same if other describe)		P155/80D-16, 16 x 4 steel wheel
	Storage position & location (describe)		Horizontal under fuel tank

**Tires And Wheels (Optional)**

Size (load range, ply)		Unidirectional P255/50VR16 B/W (RPO Z2D)
Type (bias, radial, etc)		Special high speed steel belted radial Eagle VR (Goodyear)
Wheel (type & material)		Left-Right aluminum alloy with specific vent design
Rim (size, flange type and offset)	*	16 x 8-1/2
Size (load range, ply)		Unidirectional P255/50VR16 B/W (RPO Z51)
Type (bias, radial, etc)		Special high speed steel belted radial Eagle VR (Goodyear)
Wheel (type & material)		Left-Right, frt-rr alum alloy with specific vent design
Rim (size, flange type and offset)	**	Front 16 x 8-1/2, Rear 16 x 9-1/2
Size (load range, ply)		
Type (bias, radial, etc)		
Wheel (type & material)		
Rim (size, flange type and offset)		
Size (load range, ply)		
Type (bias, radial, etc)		
Wheel (type & material)		
Rim (size, flange type and offset)		
Spare tire and wheel  (if configuration is different than road tire or wheel describe optional spare tire and/or wheel location & storage position)		T155/80D16 (aluminum 16 x 4 wheel with power seat and/or Performance Handling Package, RPO Z51)

**Brakes - Parking**

Type of control		Grip handle control
Location of control		Below the top of door sill, at the driver's left
Operates on		Rear brake drums, integral with disc rotor
If separate from service brakes	Type (internal or external)	Internal, manual duo-servo
	Drum diameter	177 (7.00)
	Lining size (length x width x thickness)	172.2 x 31.8 x 4.44 (6.78 x 1.25 x 0.175)

\* OFFSET - 32 mm front and rear,  
 \*\* OFFSET - 32 mm front, 38 mm rear

**MVMA Specifications Form**  
**Passenger Car**  
**METRIC (U.S. Customary)**

Car Line CORVETTE  
 Model Year 1984 Issued 1-10-83 Revised (\*) 4-83

Body Type And/Or  
 Engine Displacement

2-DOOR  
 HATCHBACK COUPE  
 1YY07

**Steering**

Manual (std., opt., n.a.)		Not Available	
Power (std., opt., n.a.)		Standard	
Adjustable steering wheel (tilt, swing, other)	Type and description	Black, leather-wrapped two-spoke steering wheel; Tilt and Telescopic	
	(Std., opt., n.a.)	Standard	
Wheel diameter	Manual	Not Available	
	Power	368 (14.5)	
Turning diameter m (ft.)	Outside front	Wall to wall (l & r)	12.6 (41.4)
		Curb to curb (l & r)	12.2 (40.1)
	Inside rear	Wall to wall (l & r)	7.6 (25.0)
		Curb to curb (l & r)	7.6 (25.0)
Scrub Radius			
Manual	Gear	Type	Not Available
		Make	--
		Ratios	Overall
	No wheel turns (stop to stop)		--
Power	Type (coaxial, linkage, etc.)		Alloy Rack and Pinion with integral damping
	Make		Saginaw Steering Gear; lt wt. transverse compact pump
	Gear	Type	End Take-Off
		Ratios	Overall
	Pump (drive)		Accessory Belt Driven
No wheel turns (stop to stop)		2.36 Turns-Base, 1.96 Turns-Z51 Handling Package	
Linkage	Type		End Take-Off
	Location (front or rear of wheels, other)		Front of Wheel
	Drag links (trans or longit)		--
Tie rods (one or two)		Two	
Steering axis	Inclination at camber (deg.)		8.744°
	Bearings (type)	Upper	Ball Joint(M/M W/anti-friction washer); anti-corrosive
		Lower	Ball Joint(M/M W/anti-friction washer); anti-corrosive
Thrust		Lower Ball joint	
Steering spindle & joint type		Upper and lower Ball joints; anti-corrosive	
Wheel spindle	Diameter	Inner bearing	51 mm (2.0 in)
		Outer bearing	51 mm (2.0 in)
	Thread (size)		Not Available
	Bearing (type)		Unit hub-Bearing Assembly with double row balls; anti-corrosive

**MVMA Specifications Form**  
**Passenger Car**  
**(METRIC (U.S. Customary))**

Car Line CORVETTE  
 Model Year 1984 Issued 1-10-83 Revised (\*) 4-83

Body Type And/Or  
 Engine Displacement

2-Door  
 Hatchback Coupe  
 1YY07

**Wheel Alignment**

Front wheel at curb mass (wt)	Service checking	Caster (deg)	3.0°, +/-0.8°
		Camber (deg)	0.8°, +/-0.5°
		Toe-in (deg)	0.15°, +/-0.15°
	Service reset*	Caster	--
		Camber	--
		Toe-in	--
	Periodic MV inspection	Caster	--
		Camber	--
		Toe-in	--
Rear wheel at curb mass (wt)	Service checking	Camber (deg)	0°, +/-0.5°
		Toe-in (deg)	0.15°, +/-0.06°
	Service reset*	Camber	--
		Toe-in	--
	Periodic MV inspection	Camber	--
		Toe-in	--

\* Indicates pre-set adjustable trend set or other

**Electrical - Instruments and Equipment \***

Speedometer	Type	Electronic liquid crystal-digital and analog
	Trip odometer (std. opt. na)	Standard
EGR maintenance indicator		Not available
Charge indicator	Type	Digital display
	Warning device	Standard-warning indicator and digital read-out
Temperature indicator	Type	Digital display
	Warning device	Standard-warning indicator and digital read-out
Oil pressure indicator	Type	Digital display
	Warning device	Standard-warning indicator and digital read-out
Fuel indicator	Type	Electric liquid crystal-analog
	Warning device	Standard-warning indicator signals-low fuel
Wind-shield wiper	Type (standard)	Intermittent control system
	Type (optional)	Not available
	Blade length	508 mm (20 in.)
	Swept area (cm <sup>2</sup> (in <sup>2</sup> ))	6920 (1072.9)
Wind-shield washer	Type (standard)	Push button-manual
	Type (optional)	Not available
	Fluid level indicator	Not available
Horn	Type	Vibrator
	Number used	Two

Other Tell-tale lights warning of unfastened seat belts (FASTEN BELTS), low brake line pressure or parking brake on (BRAKE), anti-theft alert (SECURITY), electronic control module malfunction (CHECK ENGINE), door ajar (DOOR AJAR), hatch ajar (HATCH AJAR), 4-speed manual overdrive engaged (OVERDRIVE ENGAGED). Drivers information system mileage range, instant and average MPG, and trip odometer also included as standard equipment.

\*English or Metric

**MVMA Specifications Form**  
**Passenger Car**  
**METRIC (U.S. Customary)**

Car Line CORVETTE  
 Model Year 1984 Issued 1-10-83 Revised (\*) 4-83

Engine Description/Carb.  
 Engine Code

5.7 Liter V6 (350 CID)  
 Cross-Fire Injection (CFI)  
 RPO 183

**Electrical - Supply System**

Battery	Make	Delco-Remy
	Model, std. (opt.)	75-500, Standard
	Voltage	12 Volts
	Amps at 0°F cold crank	550 cold cranking amps. (CCA)
	Minutes-reserve capacity	90 minute reserve capacity
	Amp-hrs - 20 hr rate	54 Amp-hrs.
	Location	Engine compartment directly behind left wheel opening
Generator or alternator	Type and rating	97 Amps
	Ratio (alt crank/rev)	3.24:1
	Optional (type & rating)	None
Regulator	Type	Micro circuit unit; integral with alternator

**Electrical - Starting System**

Start motor	Current drain at 0°F	350 Amps
Motor drive	Engagement type	Positive shift solenoid
	Pinion engages from (front/rear)	Rear

**Electrical - Ignition System**

Type	Conventional (std opt. n/a)	--	
	Electronic (std opt. n/a)	--	
	Other (specify)	High Energy Ignition (HEI)	
Coil	Make	Delco-Remy	
	Model	Integral with distributor	
	Current	Engine stopped - A	--
		Engine idling - A	--
Spark plug	Make	AC	
	Model	R45TS	
	Thread (mm)	M14 x 1.25	
	Tightening torque (N-m (lb ft))	9-20 (7-15)	
	Gap	1.143 (.045)	
Distributor	Make	Delco-Remy	
	Model	1103539	

**Electrical - Suppression**

Locations & type	Internal alternator capacitor, non-metallic high-tension cables, resistor spark plugs, ignition coil by-pass capacitor, internal AC blower motor by-pass capacitor & A/C compression diode, with radio provisions; hood grounding clip, engine to dash panel ground strap, fuse block capacitor and on "heater only" blower motors and coax capacitor.
------------------	--

**MVMA Specifications Form**  
**Passenger Car**  
**METRIC (U.S. Customary)**

Car Line CORVETTE  
 Model Year 1984 Issued 1-10-83 Revised (\*) 4-83

Body Type

2-DOOR  
 HATCHBACK COUPE  
 1Y07

**Body - Miscellaneous Information**

Type of finish (lacquer, enamel, other)		High solids acrylic enamel with final clear coat
Hood	Hinge location (front, rear)	Front
	Type (counterbalance, prop)	Hinged clamshell hood, w/upper wheelhouse attached (*)
	Release control (internal, external)	Internal
Trunk lid	Type (counterbalance, other)	--
	Internal release control (elec, mech, n/a)	--
Hatch back lid	Type (counterbalance, other)	Dual Gas Struts
	Internal release control (elec, mech, n/a)	Electric Release, Std (Each door and console glove box)
Bumper front	Bar material & mass (wt)	Fascia 4.6 (10.1)
	Reinforcement material & mass (wt)	Honeycomb and impact bar - 9.55 (21.1)
Bumper rear	Bar material & mass (wt)	Fascia 7.02 (15.5)
	Reinforcement material & mass (wt)	Alum. rear bumper extension and honeycomb - 18.2 (40.1)
Vent window control (crank, friction, pivot, power)	Front	None
	Rear	None
Seat cushion type	Front	Bucket Seat, full cloth trim w/wool pad comfort liner @
	Rear	None
	3rd seat	None
Seat back type	Front	Bucket Seat, full cloth trim w/wool pad comfort liner @
	Rear	None
	3rd seat	None
Vehicle ident no location		Top LH side of I.P. pad - visible from outside vehicle

(\*) gives easy access to engine and chassis components; folding prop rod hold open; SMC reinforced composite.

Type and description (separate frame, unitized frame, partially-unitized frame) All-welded steel body-frame construction, 100% galvanized. Bolt-on front crossmember to allow bottom loaded engine.

Glass @ - SMC reinforced composite frame for seat cushion and backrest.

Backlight slope angle (deg)	H121	72.5°
Windshield slope angle (deg)	H122	64.7°
Tumble-Home (deg)	W122	36.9°
Windshield glass exposed surface area (cm <sup>2</sup> (in <sup>2</sup> ))	S1	8710.0 (1350.4)
Side glass exposed surface area (cm <sup>2</sup> (in <sup>2</sup> ))	S2	4007.2 (621.3)
Backlight glass exposed surface area (cm <sup>2</sup> (in <sup>2</sup> ))	S3	6205.0 (962.0)
Total glass exposed surface area (cm <sup>2</sup> (in <sup>2</sup> ))	S4	18922.2 (2933.7)
Windshield glass (type)		Curved - Laminated Plate - Tinted
Side glass (type)		Curved - Tempered Plate - Tinted
Backlight glass (type)		Curved - Tempered Plate - Tinted



**MVMA Specifications Form  
Passenger Car**

Car Line CORVETTE  
 Model Year 1984 Issued 1-10-83 Revised (\*) 4-83

**METRIC (U.S. Customary)**  
**Car and Body Dimensions** See Key Sheets for definitions

Body Type

SAE Ref. No.	
--------------------	--

**Restraint System**

Active restraint system	Standard/ optional	
	Type and description	
	Location	
Passive seat belts	Standard/ optional	
	Power/ manual	
	2 or 3 point	
	Knee bar/ lap belt	



**MVMA Specifications Form**  
**Passenger Car**  
**METRIC (U.S. Customary)**

Car Line CORVETTE  
 Model Year 1984 Issued 1-10-83 Revised (\*) 4-83

**Car and Body Dimensions** See Key Sheets for definitions

\* All dimensions to ground are for comparative purposes only. Dimensions are to be shown for all base body models of each car line.  
 SAE Ref. no. refers to the definition published in SAE Recommended Practice.  
 J1100a "Motor Vehicle Dimensions," unless otherwise specified.

Body Type	SAE Ref. No.	2-DOOR HATCHBACK COUPE 1YY07
-----------	--------------	------------------------------------

**Width**

Tread (front)	W101	1513 (59.6)
Tread (rear)	W102	1534 (60.4)
Vehicle width	W103	1804 (71.0)
Body width at Sq RP (front)	-W117	1752 (69.0)
Vehicle width (front doors open)	W120	3706 (145.9)
Vehicle width (rear doors open)	W121	--

**Length**

Wheelbase	L101	2444 (96.2)
Vehicle length	L103	4483 (176.5)
Overhang (front)	L104	1030 (40.5)
Overhang (rear)	L105	1009 (39.7)
Upper structure length	L123	2309 (90.9)
Rear wheel C/L "X" coordinate	L127	1886 (74.2)
Cowl point "X" coordinate	L125	174 (6.8)

**Height \*\***

Passenger distribution (frt/rear)	PD1.2.3		**
Trunk/cargo load			**
Vehicle height	H101	1186 (46.7)	
Cowl point to ground	H114	852 (33.5)	
Deck point to ground	H138		
Rocker panel-front to ground	H112	183 (7.2)	
Bottom of door closed-front to grd	H133	256 (10.1)	
Rocker panel-rear to ground	H111	181 (7.1)	
Bottom of door closed-rear to grd	H135	--	

**Ground Clearance \*\***

Front bumper to ground	H102	133 (5.2)
Rear bumper to ground	H104	335 (13.2)
Bumper to ground (front at curb mass (wt))	H103	140 (5.5)
Bumper to ground (rear at curb mass (wt))	H105	350 (13.8)
Angle of approach	H106	11.4°
Angle of departure	H107	34.8°
Ramp breakover angle	H147	12.4°
Rear axle differential to ground	H153	172 (6.8)
Min. running ground clearance	H156	127 (5.0)
Location of min run grd clear		Catalytic Converter

All linear dimensions are in millimeters (inches) and all mass (weight) specifications are in kilograms (pounds)

**\*\* All Vehicle Height And Ground Clearances Are Made Using EPA Loaded Vehicle Weight, Loading Conditions.**

EPA LOADED VEHICLE WEIGHT Is The Base Vehicle Weight Plus All Coolant And Fluids Necessary For Operation Plus 100% Of The Fuel Capacity, Plus The Weight Of All Options And Accessories Which Weigh Three Pounds Or More And Which Are Sold On At Least 33% Of The Car Line, Plus Two Occupants.

# MVMA Specifications Form

## Passenger Car

Car Line CORVETTE  
 Model Year 1984 Issued 1-10-83 Revised (\*) 4-83

METRIC (U.S. Customary)

Car and Body Dimensions See Key Sheets for definitions

Body Type

<b>SAE Ref. No.</b>	2-DOOR HATCHBACK COUPE 1YY07
---------------------	------------------------------------

### Front Compartment

Sg RP front, "X" coordinate	L31	1150 (45.3)
Effective head room	H61	926 (36.4)
Max. eff. leg room (accelerator)	L34	1083 (42.6)
Sg RP (front to heel)	H30	188 (7.4)
Design H-point front travel	L17	146.5 (5.8)
Shoulder room	W3	1373 (54.0)
Hip room	W5	1253 (49.3)
Upper body opening to ground	H50	1099 (43.3)
Steering wheel angle	H18	18.4°
Back angle	L40	28.0°

### Rear Compartment

Sg RP Point couple distance	L50	
Effective head room	H63	
Min. effective leg room	L51	NOT
Sg RP (second to heel)	H31	
Knee clearance	L48	APPLICABLE
Compartment room	L3	
Shoulder room	W4	
Hip room	W6	
Upper body opening to ground	H51	

### Luggage Compartment

Usable luggage capacity (L cu ft)	V1	--
Liftover height	H195	906 (35.7)

All linear dimensions are in millimeters (inches)

# MVMA Specifications Form Passenger Car

METRIC (U.S. Customary)

Car and Body Dimensions See Key Sheets for definitions

Car Line CORVETTE  
 Model Year 1984 Issued 1-10-83 Revised (\*) 4-83

Body Type	SAE Ref. No.	2-DOOR HATCHBACK COUPE 1Y07
-----------	--------------	-----------------------------------

### Station Wagon - Third Seat

Shoulder room	W85	
Hip room	W86	NOT
Effective leg room	L86	APPLICABLE
Effective head room	H86	
Effective T-point head room	H89	
Seat facing direction	SD1	

### Station Wagon - Cargo Space

Cargo length (open front)	L200	
Cargo length (open second)	L201	
Cargo length (closed front)	L202	
Cargo length (closed second)	L203	NOT
Cargo length at belt (front)	L204	APPLICABLE
Cargo length at belt (second)	L205	
Cargo width (wheelhouse)	W201	
Rear opening width at floor	W203	
Opening width at belt	W204	
Max rear opening width above belt	W205	
Cargo height	H201	
Rear opening height	H202	
Tailgate to ground height	H250	
Front seat back to load floor height	H197	
Cargo volume index (m <sup>3</sup> (ft <sup>3</sup> ))	V2	
Hidden cargo volume (m <sup>3</sup> (ft <sup>3</sup> ))	V4	

### Hatchback - Cargo Space

Front seat back to load floor height	H197	454 (17.9)
Cargo length at front seat back height	L208	792 (31.2)
Cargo length at floor (front)	L209	838 (33.0)
Cargo volume index (m <sup>3</sup> (ft <sup>3</sup> ))	V3	508 (17.9)
Hidden cargo volume (m <sup>3</sup> (ft <sup>3</sup> ))	V4	--

### Aerodynamics\*

Wheel lip to ground front	
Wheel lip to ground rear	
Frontal area	

\* Describe measurement method.

A printed or computer tape supplement containing additional car and body dimensions and/or drawings (based in part on SAE J1100s "Motor Vehicle Dimensions") may be available from the manufacturer.

All dimensions are in millimeters (inches).

**MVMA Specifications Form**  
**Passenger Car**

Car Line CORVETTE  
 Model Year 1984 Issued 1-10-83 Revised (\*) 4-83

**METRIC (U.S. Customary)**  
**Car and Body Dimensions** See Key Sheets for definitions

Body Type	2-DOOR HATCHBACK COUPE 1YY07
-----------	------------------------------------

**Vehicle Fiducial Marks**

Fiducial Mark Number*		Define Coordinate Location
Front	X	Fiducial mark to vertical base grid line - front, measured horizontally from the base grid line to the front fiducial mark located on top of the front seat adjuster mounting bolt.
	Y	Fiducial mark to centerline of car - front, width measurement made from centerline of car to the fiducial mark located on top of the front seat adjuster mounting bolt.
	Z	Fiducial mark to horizontal base gridline - front, measured vertically from base grid line to front fiducial mark located on top of the front seat adjuster mounting bolt.
Rear	X	Fiducial mark to vertical base grid line - rear, measured horizontally from base grid line to the rear fiducial mark located on rear underbody crossbar.
	Y	Fiducial mark to centerline of car - rear, width measurement made from centerline of car to fiducial mark located on rear underbody crossbar.
	Z	Fiducial mark to horizontal base grid line - rear, measured vertically from base grid line to the rear fiducial mark located on rear underbody crossbar.
Front	W21	366 (14.4)
	L54	2831 (111.4)
	H81	422 (16.6)
	H161	180 (7.1)
	** H163	168 (6.6)
Rear	W22	546 (21.5)
	L55	4714 (185.6)
	H82	546 (21.5)
	H162	363 (14.3)
	** H164	346 (13.6)

\* Reference - SAE Recommended Practice, J182a, Motor Vehicle Fiducial Marks - September, 1973  
 All linear dimensions are in millimeters (inches)

\*\* EPA Loaded Vehicle Weight, Loading Conditions

# MVMA Specifications Form

## Passenger Car

METRIC (U.S. Customary)

Car and Body Dimensions See Key Sheets for definitions

Car Line CORVETTE  
 Model Year 1984 Issued 1-10-83 Revised (\*) 4-83

Body Type

<b>SAE Ref. No.</b>	2-DOOR HATCHBACK COUPE 1YY07
---------------------	------------------------------------

### Lamps and Headlamp Shape\*

Height above ground to center of bulb or marker	Headlamp (H127)	Highest**	664.9 (26.2)
		Lowest	--
	Taillamp (H128)	Highest**	765.1 (30.1)
		Lowest	762.7 (30.0)
	Sidemarker	Front	476.8 (18.8)
		Rear	555.5 (21.9)
Distance from C/L of car to center of bulb	Headlamp	Inside	--
		Outside**	544.0 (21.4)
	Taillamp	Inside	410.1 (16.1)
		Outside**	625.1 (24.6)
	Directional	Front	485.0 (19.1)
		Rear	625.1 (24.6)
Headlamp shape			Rectangular

\* Measured at curb mass (weight)  
 \*\* If single lamps are used enter here









# MVMA Specifications Form

## Passenger Car

METRIC (U.S. Customary)

### Exterior Car And Body Dimensions – Key Sheet

#### Exterior Width

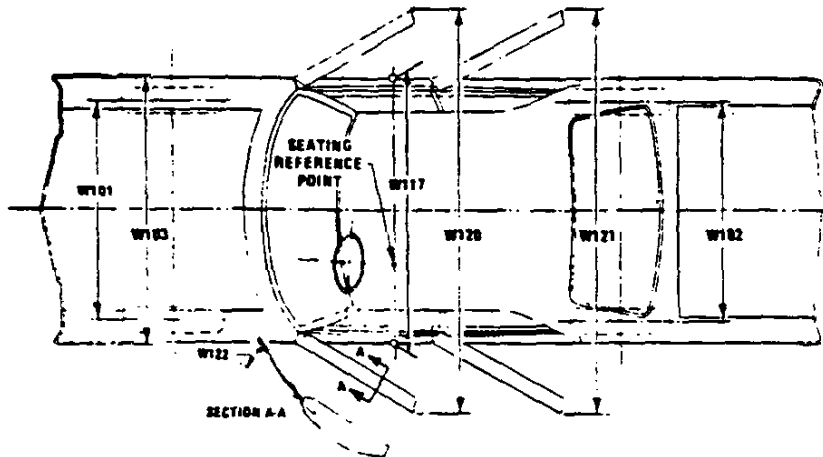

#### Exterior Length & Height

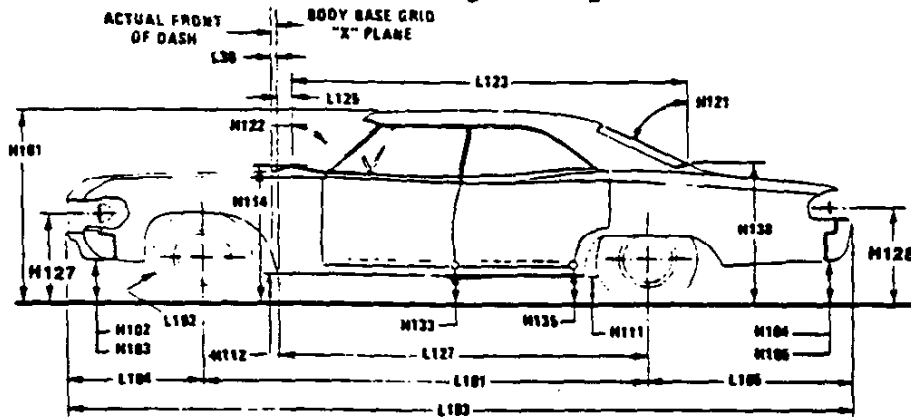

#### Exterior Ground Clearance



#### Cargo Space

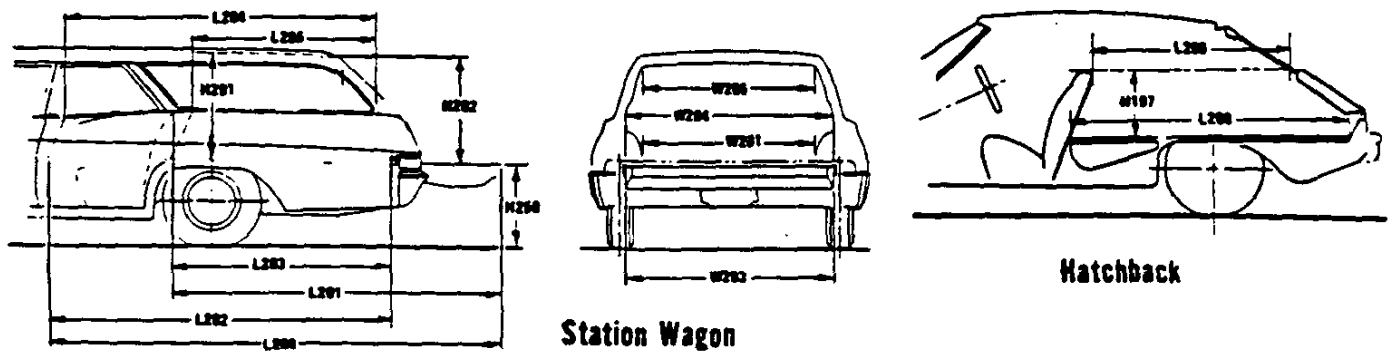

**MVMA Specifications Form**  
**Passenger Car**  
**METRIC (U.S. Customary)**

**Interior Car And Body Dimensions – Key Sheet**

**Front Compartment**

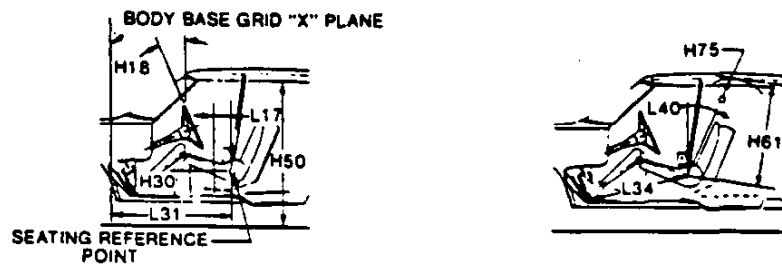

**Rear Compartment**

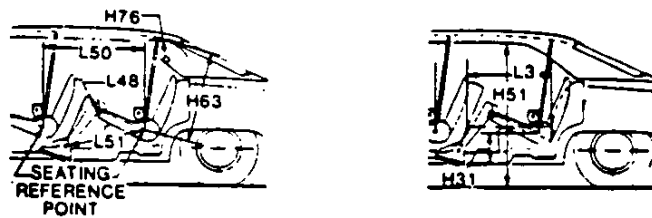

**Third Seat**

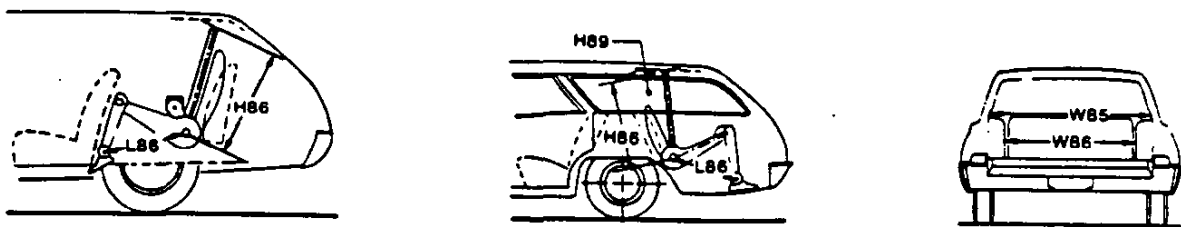

**Interior Width**

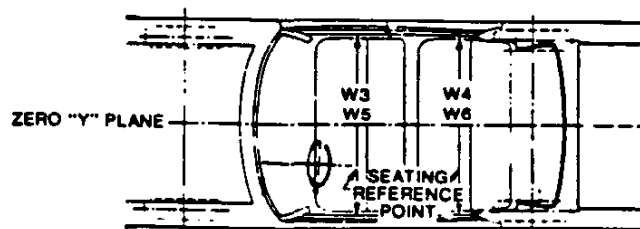

# MVMA Specifications Form

## Passenger Car

### METRIC (U.S. Customary)

#### Exterior Car And Body Dimensions — Key Sheet

##### Dimensions Definitions

##### Seating Reference Point

**SEATING REFERENCE POINT** means the manufacturer's design reference point which —

- (a) Establishes the rearmost normal design driving or riding position of each designated seating position in a vehicle;
- (b) Has coordinates established relative to the design vehicle structure;
- (c) Simulates the position of the pivot center of the human torso and thigh; and
- (d) Is the reference point employed to position the two dimensional templates described in SAE Recommended Practice J826, "Manikins for Use in Defining Vehicle Seating Accommodations," November 1962.

##### Width Dimensions

- W101 **TREAD—FRONT** The dimension measured between the tire centerlines at the ground
- W102 **TREAD—REAR** The dimension measured between the tire centerlines at the ground. In case of dual wheels, the dimension will be measured to the centerline of tire and wheel assemblies
- W103 **VEHICLE WIDTH** The maximum dimension measured between the widest point on the vehicle, excluding exterior mirrors, flexible mud flaps, marker lamps, but including bumpers, moldings, sheet metal protrusions or dual wheels, if standard equipment.
- W117 **BODY WIDTH AT SgRP—FRONT** The dimension measured laterally between the widest points on the body at the SgRP-front, excluding door handles, applied moldings, or appliques.
- W120 **VEHICLE WIDTH—FRONT DOORS OPEN** The dimension measured between the widest point on the front doors in maximum hold-open position
- W121 **VEHICLE WIDTH—REAR DOORS OPEN** The dimension measured between the widest point on the rear doors in maximum hold-open position. For vehicles with a rear door on only one side, this dimension is to the zero "Y" plane
- W122 **TUMBLE HOME STRAIGHT SIDE GLASS** The angle measured from a vertical to the outside surface of the front door glass at the SgRP "X" plane.  
**CURVED SIDE GLASS.** The angle measured from a vertical to a chord extending from the upper DLO to the lower DLO at the outside surface of the front door glass at the front SgRP "X" plane.

##### Length Dimensions

- L30 **FRONT OF DASH "X" COORDINATE** A minus (-) dimension indicates actual front of dash in forward of the zero "X" plane
- L101 **WHEELBASE (WB).** The dimension measured longitudinally between front and rear wheel centerlines. In case of dual rear axles, the dimension shall be to the midpoint of the centerlines of the rear wheels
- L102 **TIRE SIZE.** As specified by the manufacturer.
- L103 **VEHICLE LENGTH.** The maximum dimension measured longitudinally between the foremost point and the rearmost point on the vehicle, including bumper, bumper guards, tow hooks and/or rub strips, if standard equipment.
- L104 **OVERHANG—FRONT.** The dimension measured longitudinally from the centerline of the front wheels to the foremost point on the vehicle including bumper, bumper guards, tow hooks and/or rub strips, if standard equipment.

- L105 **OVERHANG—REAR** The dimension measured longitudinally from the centerline of the rear wheels, or in the case of dual rear axles, the dimension shall be the midpoint of the centerlines of the rear wheels, to the rearmost point on the vehicle, including rear bumpers, bumper guards, tow hooks and rub strips, if standard equipment.
- L123 **UPPER STRUCTURE LENGTH** The dimension measured longitudinally from the cowl point to the deck point
- L127 **REAR WHEEL CENTERLINE "X" COORDINATE** or in the case of dual rear axles, the coordinate shall be in the midpoint of the distance between the rear axle centerlines
- L125 **COWL POINT "X" COORDINATE.**

##### Height Dimensions

- H101 **VEHICLE HEIGHT** The dimension measured vertically from the highest point on the vehicle body to ground
- H114 **COWL POINT TO GROUND** Measured at zero "Y" plane
- H13B **DECK POINT TO GROUND.** Measured at zero "Y" plane
- H112 **ROCKER PANEL—FRONT TO GROUND** The dimension measured vertically from the foremost point on the bottom of the rocker panels, excluding flanges to ground
- H132 **BOTTOM OF DOOR OPEN—FRONT TO GROUND** The dimension measured vertically from the bottom outside corner of the door on the lock pillar side, maximum hold-open position, to ground
- H111 **ROCKER PANEL—REAR TO GROUND.** The dimension measured vertically from the bottom of the rocker or side quarter panel at the front of the rear wheel opening, excluding flanges, to ground
- H134 **BOTTOM OF DOOR OPEN—REAR TO GROUND** The dimension measured vertically from the bottom outside corner of the door on the lock pillar side, in maximum hold-open position, to ground
- H135 **BOTTOM OF DOOR CLOSED—REAR TO GROUND** The dimension measured vertically from the bottom outside corner of the door on the lock pillar side, in maximum closed position, to ground
- H121 **BACKLIGHT SLOPE ANGLE** The angle between the vertical reference line and the surface of backlight at vehicle zero "Y" plane. For curve backlight, the angle is to chord of backlight arc from lower DLO to upper DLO.
- H122 **WINDSHIELD SLOPE ANGLE** The angle between the vertical reference line and a chord of the windshield are running from the lower DLO to the upper DLO at the vehicle zero "Y" plane. In the case of wrap over glass, the angle to be measured will be formed by a chord 457 mm (18 0 in) long drawn from the lower DLO to the intersecting point on the windshield
- H127 **HEADLAMP TO GROUND—CURB MASS (WT)** The dimension measured vertically from the centerline of the lowest headlamp lens to ground
- H128 **TAILLAMP TO GROUND—CURB MASS (WT)** The dimension measured vertically from the centerline of the upper bulb to ground

##### Ground Clearance Dimensions

- H102 **FRONT BUMPER TO GROUND** The minimum dimension measured vertically from the lowest point on front bumper to ground, including bumper guards, if standard equipment

General Motors Corporation  
**CHEVROLET MOTOR DIVISION**

**PRODUCT DESCRIPTION MANUAL**

REF 11E  REF 11E  REF 11C  REF 11C

MASS INITIAL  MASS INITIAL  IMAGE  IMAGE  LISTING 65 PART #  LISTING 65 PART #

GM Assembly Division General Motors Corporation Warren, Michigan 48090

**PROCESS SHEET**

1	2	3	4

- REF 11E  SUPPORT-RADIATOR UPPER
- REF 11E  SUPPORT-RADIATOR LOWER
- REF 11C  Baffle-RADIATOR LOWER AIR
- REF 11C  Baffle-RADIATOR UPPER AIR

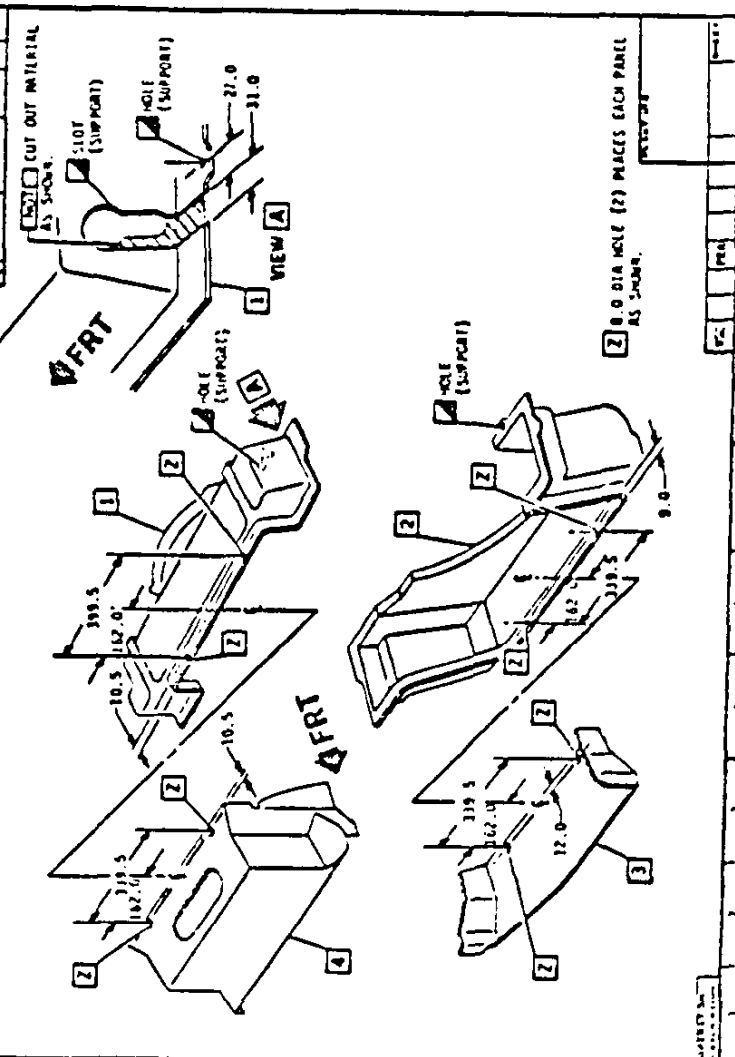

1984 Y PASSENGER 14062674	
ENGINE OIL COOLER RADIATOR SUPPORT & BAFFLE	
TA000 84C4 8ND1/NT7	
CHEVROLET	11-23382 (3)
ECR 26310	6G3
C/O ZPM02	SMIT
C1	C1



# PRODUCT DESCRIPTION MANUAL

1811000 03 PART 00

General Motors Corporation  
 CHEVROLET MOTOR DIVISION

GM Assembly Division General Motors Corporation Warren, Michigan 48090

## PROCESS SHEET

DATE: \_\_\_\_\_

REV: \_\_\_\_\_

BY: \_\_\_\_\_

CHKD BY: \_\_\_\_\_

DATE: \_\_\_\_\_

TIME: \_\_\_\_\_

SCALE: \_\_\_\_\_

UNIT: \_\_\_\_\_

PROJ: \_\_\_\_\_

WKS: \_\_\_\_\_

DAY: \_\_\_\_\_

MONTH: \_\_\_\_\_

YEAR: \_\_\_\_\_

TIME: \_\_\_\_\_

SCALE: \_\_\_\_\_

UNIT: \_\_\_\_\_

PROJ: \_\_\_\_\_

WKS: \_\_\_\_\_

DAY: \_\_\_\_\_

MONTH: \_\_\_\_\_

YEAR: \_\_\_\_\_

TIME: \_\_\_\_\_

SCALE: \_\_\_\_\_

UNIT: \_\_\_\_\_

PROJ: \_\_\_\_\_

WKS: \_\_\_\_\_

DAY: \_\_\_\_\_

MONTH: \_\_\_\_\_

YEAR: \_\_\_\_\_

TIME: \_\_\_\_\_

SCALE: \_\_\_\_\_

UNIT: \_\_\_\_\_

PROJ: \_\_\_\_\_

WKS: \_\_\_\_\_

DAY: \_\_\_\_\_

MONTH: \_\_\_\_\_

YEAR: \_\_\_\_\_

TIME: \_\_\_\_\_

SCALE: \_\_\_\_\_

UNIT: \_\_\_\_\_

PROJ: \_\_\_\_\_

WKS: \_\_\_\_\_

DAY: \_\_\_\_\_

MONTH: \_\_\_\_\_

YEAR: \_\_\_\_\_

TIME: \_\_\_\_\_

SCALE: \_\_\_\_\_

UNIT: \_\_\_\_\_

PROJ: \_\_\_\_\_

WKS: \_\_\_\_\_

DAY: \_\_\_\_\_

MONTH: \_\_\_\_\_

YEAR: \_\_\_\_\_

TIME: \_\_\_\_\_

SCALE: \_\_\_\_\_

UNIT: \_\_\_\_\_

PROJ: \_\_\_\_\_

WKS: \_\_\_\_\_

DAY: \_\_\_\_\_

MONTH: \_\_\_\_\_

YEAR: \_\_\_\_\_

TIME: \_\_\_\_\_

SCALE: \_\_\_\_\_

UNIT: \_\_\_\_\_

PROJ: \_\_\_\_\_

WKS: \_\_\_\_\_

DAY: \_\_\_\_\_

MONTH: \_\_\_\_\_

YEAR: \_\_\_\_\_

TIME: \_\_\_\_\_

SCALE: \_\_\_\_\_

UNIT: \_\_\_\_\_

PROJ: \_\_\_\_\_

WKS: \_\_\_\_\_

DAY: \_\_\_\_\_

MONTH: \_\_\_\_\_

YEAR: \_\_\_\_\_

TIME: \_\_\_\_\_

SCALE: \_\_\_\_\_

UNIT: \_\_\_\_\_

PROJ: \_\_\_\_\_

WKS: \_\_\_\_\_

DAY: \_\_\_\_\_

MONTH: \_\_\_\_\_

YEAR: \_\_\_\_\_

TIME: \_\_\_\_\_

SCALE: \_\_\_\_\_

UNIT: \_\_\_\_\_

PROJ: \_\_\_\_\_

WKS: \_\_\_\_\_

DAY: \_\_\_\_\_

MONTH: \_\_\_\_\_

YEAR: \_\_\_\_\_

TIME: \_\_\_\_\_

SCALE: \_\_\_\_\_

UNIT: \_\_\_\_\_

PROJ: \_\_\_\_\_

WKS: \_\_\_\_\_

DAY: \_\_\_\_\_

MONTH: \_\_\_\_\_

YEAR: \_\_\_\_\_

TIME: \_\_\_\_\_

SCALE: \_\_\_\_\_

UNIT: \_\_\_\_\_

PROJ: \_\_\_\_\_

WKS: \_\_\_\_\_

DAY: \_\_\_\_\_

MONTH: \_\_\_\_\_

YEAR: \_\_\_\_\_

TIME: \_\_\_\_\_

SCALE: \_\_\_\_\_

UNIT: \_\_\_\_\_

PROJ: \_\_\_\_\_

WKS: \_\_\_\_\_

DAY: \_\_\_\_\_

MONTH: \_\_\_\_\_

YEAR: \_\_\_\_\_

TIME: \_\_\_\_\_

SCALE: \_\_\_\_\_

UNIT: \_\_\_\_\_

PROJ: \_\_\_\_\_

WKS: \_\_\_\_\_

DAY: \_\_\_\_\_

MONTH: \_\_\_\_\_

YEAR: \_\_\_\_\_

TIME: \_\_\_\_\_

SCALE: \_\_\_\_\_

UNIT: \_\_\_\_\_

PROJ: \_\_\_\_\_

WKS: \_\_\_\_\_

DAY: \_\_\_\_\_

MONTH: \_\_\_\_\_

YEAR: \_\_\_\_\_

TIME: \_\_\_\_\_

SCALE: \_\_\_\_\_

UNIT: \_\_\_\_\_

PROJ: \_\_\_\_\_

WKS: \_\_\_\_\_

DAY: \_\_\_\_\_

MONTH: \_\_\_\_\_

YEAR: \_\_\_\_\_

TIME: \_\_\_\_\_

SCALE: \_\_\_\_\_

UNIT: \_\_\_\_\_

PROJ: \_\_\_\_\_

WKS: \_\_\_\_\_

DAY: \_\_\_\_\_

MONTH: \_\_\_\_\_

YEAR: \_\_\_\_\_

TIME: \_\_\_\_\_

SCALE: \_\_\_\_\_

UNIT: \_\_\_\_\_

PROJ: \_\_\_\_\_

WKS: \_\_\_\_\_

DAY: \_\_\_\_\_

MONTH: \_\_\_\_\_

YEAR: \_\_\_\_\_

TIME: \_\_\_\_\_

SCALE: \_\_\_\_\_

UNIT: \_\_\_\_\_

PROJ: \_\_\_\_\_

WKS: \_\_\_\_\_

DAY: \_\_\_\_\_

MONTH: \_\_\_\_\_

YEAR: \_\_\_\_\_

TIME: \_\_\_\_\_

SCALE: \_\_\_\_\_

UNIT: \_\_\_\_\_

PROJ: \_\_\_\_\_

WKS: \_\_\_\_\_

DAY: \_\_\_\_\_

MONTH: \_\_\_\_\_

YEAR: \_\_\_\_\_

TIME: \_\_\_\_\_

SCALE: \_\_\_\_\_

UNIT: \_\_\_\_\_

PROJ: \_\_\_\_\_

WKS: \_\_\_\_\_

DAY: \_\_\_\_\_

MONTH: \_\_\_\_\_

YEAR: \_\_\_\_\_

TIME: \_\_\_\_\_

SCALE: \_\_\_\_\_

UNIT: \_\_\_\_\_

PROJ: \_\_\_\_\_

WKS: \_\_\_\_\_

DAY: \_\_\_\_\_

MONTH: \_\_\_\_\_

YEAR: \_\_\_\_\_

TIME: \_\_\_\_\_

SCALE: \_\_\_\_\_

UNIT: \_\_\_\_\_

PROJ: \_\_\_\_\_

WKS: \_\_\_\_\_

DAY: \_\_\_\_\_

MONTH: \_\_\_\_\_

YEAR: \_\_\_\_\_

TIME: \_\_\_\_\_

SCALE: \_\_\_\_\_

UNIT: \_\_\_\_\_

PROJ: \_\_\_\_\_

WKS: \_\_\_\_\_

DAY: \_\_\_\_\_

MONTH: \_\_\_\_\_

YEAR: \_\_\_\_\_

TIME: \_\_\_\_\_

SCALE: \_\_\_\_\_

UNIT: \_\_\_\_\_

PROJ: \_\_\_\_\_

WKS: \_\_\_\_\_

DAY: \_\_\_\_\_

MONTH: \_\_\_\_\_

YEAR: \_\_\_\_\_

TIME: \_\_\_\_\_

SCALE: \_\_\_\_\_

UNIT: \_\_\_\_\_

PROJ: \_\_\_\_\_

WKS: \_\_\_\_\_

DAY: \_\_\_\_\_

MONTH: \_\_\_\_\_

YEAR: \_\_\_\_\_

TIME: \_\_\_\_\_

SCALE: \_\_\_\_\_

UNIT: \_\_\_\_\_

PROJ: \_\_\_\_\_

WKS: \_\_\_\_\_

DAY: \_\_\_\_\_

MONTH: \_\_\_\_\_

YEAR: \_\_\_\_\_

TIME: \_\_\_\_\_

SCALE: \_\_\_\_\_

UNIT: \_\_\_\_\_

PROJ: \_\_\_\_\_

WKS: \_\_\_\_\_

DAY: \_\_\_\_\_

MONTH: \_\_\_\_\_

YEAR: \_\_\_\_\_

TIME: \_\_\_\_\_

SCALE: \_\_\_\_\_

UNIT: \_\_\_\_\_

PROJ: \_\_\_\_\_

WKS: \_\_\_\_\_

DAY: \_\_\_\_\_

MONTH: \_\_\_\_\_

YEAR: \_\_\_\_\_

TIME: \_\_\_\_\_

SCALE: \_\_\_\_\_

UNIT: \_\_\_\_\_

PROJ: \_\_\_\_\_

WKS: \_\_\_\_\_

DAY: \_\_\_\_\_

MONTH: \_\_\_\_\_

YEAR: \_\_\_\_\_

TIME: \_\_\_\_\_

SCALE: \_\_\_\_\_

UNIT: \_\_\_\_\_

PROJ: \_\_\_\_\_

WKS: \_\_\_\_\_

DAY: \_\_\_\_\_

MONTH: \_\_\_\_\_

YEAR: \_\_\_\_\_

TIME: \_\_\_\_\_

SCALE: \_\_\_\_\_

UNIT: \_\_\_\_\_

PROJ: \_\_\_\_\_

WKS: \_\_\_\_\_

DAY: \_\_\_\_\_

MONTH: \_\_\_\_\_

YEAR: \_\_\_\_\_

TIME: \_\_\_\_\_

SCALE: \_\_\_\_\_

UNIT: \_\_\_\_\_

PROJ: \_\_\_\_\_

WKS: \_\_\_\_\_

DAY: \_\_\_\_\_

MONTH: \_\_\_\_\_

YEAR: \_\_\_\_\_

TIME: \_\_\_\_\_

SCALE: \_\_\_\_\_

UNIT: \_\_\_\_\_

PROJ: \_\_\_\_\_

WKS: \_\_\_\_\_

DAY: \_\_\_\_\_

MONTH: \_\_\_\_\_

YEAR: \_\_\_\_\_

TIME: \_\_\_\_\_

SCALE: \_\_\_\_\_



---

---



General Motors Corporation  
**CHEVROLET MOTOR DIVISION**

**PRODUCT DESCRIPTION MANUAL**

□ AIR BURNER ◇ MASS AIRFLOW △ THERMISTAN

GM Assembly Division General Motors Corporation Warren, Michigan 48090

**PROCESS SHEET**

REV	DATE	BY	CHKD

OFF LINE SUB-ASSEMBLY OPERATION:

(1) INSTALL 1.8 IN INSULATOR **5** IN BOTTOM RADIATOR SUPPORT-LOWER **3**. BEHIND INSULATOR **5** BY PULLING "CAMBROT" SEALING LIP INTO MOUNTING HOLE.  
**NOTE:** FLAT SIDE OF 1.8 IN INSULATOR **5** TO BE INSTALLED INWARDS.

(2) INSTALL "U" BUSH **2** TO HOLES IN TOP FLANGE OF RADIATOR SUPPORT **3** & "U" BUSH **4** TO HOLES IN SIDE AND BOTTOM FLANGE OF RADIATOR SUPPORT **3**.

(3) PLACE RADIATOR AND CONDENSER ASSEMBLY IN LOWER RADIATOR SUPPORT **3** AND FULLY SEAT OUTER ENDS ON INSULATOR.

ON LINE ASSEMBLY OPERATION:

(4) INSTALL LOWER RADIATOR SUPPORT **3** TO TOP OF FRAME SIDE RAILS AND SECURE WITH BUSH/SLEEVE **1**.

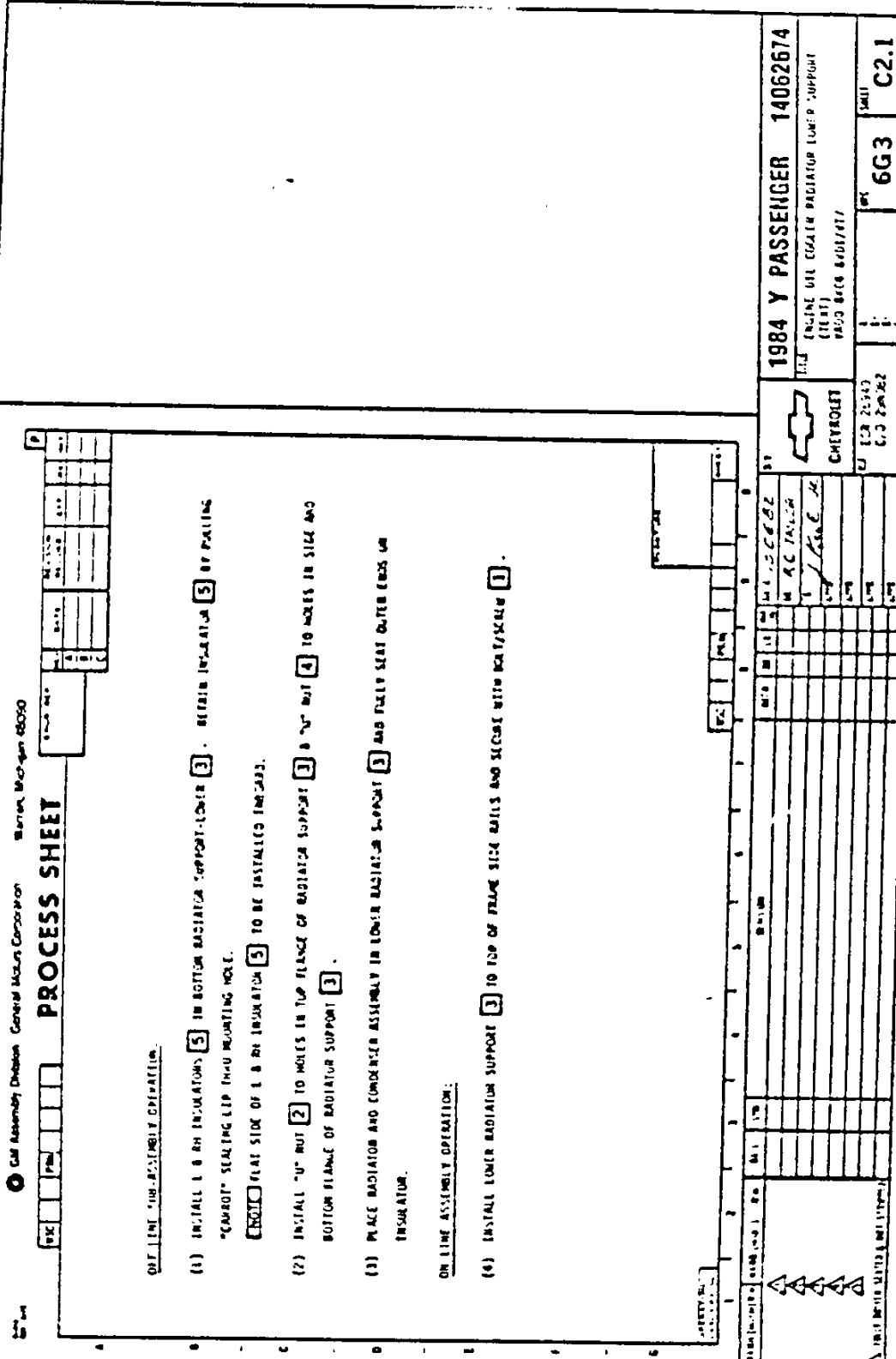

		<b>1984 Y PASSENGER 14062674</b>	
CHEVROLET		THIS ENGINE OIL GRADE RADIATOR LOWER SUPPORT (FEET)	
1984 Y PASSENGER		14062674	
1984 Y PASSENGER	14062674	6G3	C2.1

---

---



---

---



---

---





---

---



---

---























**PRODUCT DESCRIPTION MANUAL**

General Motors Corporation  
**CHEVROLET MOTOR DIVISION**



GM Assembly Division General Motors Corporation Warren, Michigan 48090

**PROCESS SHEET**

DATE	TIME	OPERATOR

- (1) LOOSELY ASSEMBLE OUTLET HOSE ASM [9] TO ADAPTER UPPER FITTING [8] & INLET HOSE ASM [10] TO ADAPTER LOWER FITTING [8].
- (2) POSITION INLET HOSE ASM [10] & OUTLET HOSE ASM [9] TO BRACKET ASM [13]. INSTALL CLAMP [12] & LOOSELY ATTACH TO BRACKET ASM [13] USING BOLT/SCREW [11].
- (3) ASSEMBLE CLIP [16] TO INLET HOSE ASM [10] & OUTLET HOSE ASM [9] AND POSITION AS SHOWN.
- (4) ATTACH CLIP [16] TO ENGINE SIDE RAIL WITH BOLT/SCREW [17].
- (5) SECURE ALL LOOSE ATTACHMENTS IN SEQUENCE OF ASSEMBLY.
- (6) ATTACH FRONT PORTION OF INLET HOSE ASM [10] & OUTLET HOSE ASM [9] TO INLET & OUTLET PIPES AND TORQUE.

OPERATOR	DATE	TIME	OPERATOR	DATE	TIME

		<b>1984 Y PASSENGER 14062674</b>	
CHEVROLET		ENGINE OIL COOLER HOSE ASM & OIL FILTER (TEXT) PADD BRACKET ASSEMBLY	
C/P (CH 26940 C/O 07JND)	P/C <b>6G3</b>	UNIT <b>C7.2</b>	PART

