

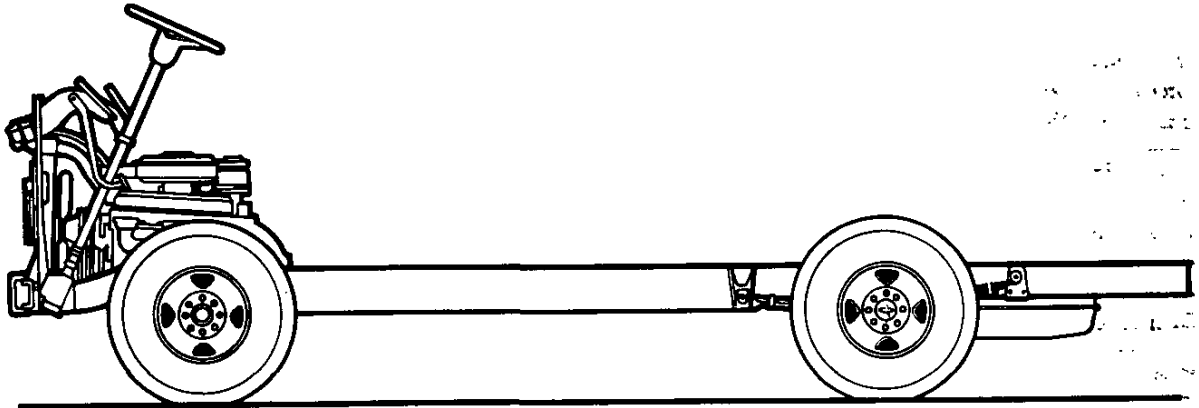

1984

# MOTOR HOME CHASSIS

## MOTOR HOME CHASSIS MODEL SELECTOR



SERIES	MODEL NUMBER				BODY ORDERING CODE	
	125" WB	137" WB	158.5" WB	178" WB	GASOLINE MODELS	DIESEL MODELS
P30/3500	P30832	P31132	P31432	*P31832	ZW9	ZW9/B3J

\*178" WB P31832 model not available with diesel engine.

**GASOLINE**

# MOTOR HOME CHASSIS

## STANDARD SPECIFICATIONS

(See Gray Tab Section for Specification Details)

Model	P30832, P31132, P31432	P31832
<b>Engine</b> .....	7.4 Liter 454 4-bbl. V8	
<b>Air Filter</b> .....	Polyurethane-wrapped Oiled-paper	
<b>Oil Filter</b> .....	Throwaway Type	
<b>Oil Cooler</b> .....	Standard	
<b>Exhaust System</b> .....	Dual; Aluminized	
<b>Emission Control Systems</b> .....	See Engine & Cooling Section for specific model applications	
<b>Suspension, Front</b> .....	Independent	
<b>Type</b> .....	Coil Springs with Auxiliary Air Springs	
<b>Capacity</b> .....	4300 lb.	5000 lb.
<b>Springs @ Ground</b> .....	2500 lb. ea.	
<b>Shock Absorbers</b> .....	35mm dia.	
<b>Stabilizer Bar</b> .....	1.25" dia.	
<b>Suspension, Rear</b> .....	Salisbury Axle, Hypoid Drive; Two-stage Multi-leaf Springs	
<b>Axle Capacity</b> .....	7900 lb.	10,000 lb.
<b>Axle Ratio</b> .....	4.10	4.56
<b>Springs @ Ground</b> .....	3100 lb. ea.	5000 lb. ea.
<b>Shock Absorbers</b> .....	32mm dia.	35mm dia.
<b>Stabilizer Bar</b> .....	1.75" dia.	1.75" dia.
<b>Brakes</b> .....	Hydraulic; Self-adjusting	
<b>Front</b> .....	Disc; 12.5" Rotor	Disc; 14.25" Rotor
<b>Rear</b> .....	Drum; 13" x 3.5"	Disc; 13.75" Rotor
<b>Booster</b> .....	Hydraulic Power	Hydraulic Power
<b>Parking</b> .....	Cable to Rear Wheels	Prop Shaft
<b>Electrical</b> .....	12 Volt; Negative Ground	
<b>Battery - Freedom Type</b> .....	515 CCA♦ @ 0°F.	
<b>- Reserve Capacity</b> .....	115 min. @ 80°F.	
<b>Delcotron Generator</b> .....	66 amp.	
<b>Frame</b> .....	Carbon Steel; 36,39,000 psi	
<b>Section Modulus</b> .....	125", 137" WB-5.26	6.12
	158.5" WB-6.12	
<b>Fuel Tank (nominal capacity)</b> .....	40 gal.	
<b>Permanent</b> .....	5 qt.	
<b>Temporary</b> .....		
<b>Steering Gear Type</b> .....	Integral Power	
<b>Steering Wheel</b> .....	Comfortilt	
<b>Transmission</b> .....	3-Speed Automatic	
<b>Shift Location</b> .....	Steering Column	
<b>Oil Cooler</b> .....	Standard; Integral with Radiator	
<b>Tires</b> .....	Tubeless	
<b>Front</b> .....	(2) LT215/85R16D (8PR)	(2) 8-19.5D (8PR)
<b>Rear</b> .....	(4) LT215/85R16C (6PR) (Dual)	(4) 8-19.5D (8PR) (Dual)
<b>Wheels</b> .....	(6) 16" x 6"	(6) 19.5" x 6.0"

♦CCA-Cold Cranking Amps

# MOTOR HOME CHASSIS

## STANDARD SPECIFICATIONS

**DIESEL**

(See Gray Tab Section for Specification Details)

Model▲	P30832, P31132, P31432
<b>Engine</b> <b>Air Filter</b> <b>Oil Filter</b> <b>Oil Cooler</b> <b>Exhaust System</b> <b>Emission Control Systems</b>	6.2 Liter 379 Cu. In. V8 Diesel Poly-wrapped Oiled-paper Element Throwaway Type Standard Dual; Aluminized See Engine & Cooling Section for specific model applications
<b>Suspension, Front</b> <b>Type</b> <b>Capacity</b> <b>Springs @ Ground</b> <b>Shock Absorbers</b> <b>Stabilizer Bar</b>	Independent Coil Springs with Auxiliary Air Springs 4300 lb. 2500 lb. ea. 35mm dia. 1.25" dia.
<b>Suspension, Rear</b> <b>Axle Capacity</b> <b>Axle Ratio</b> <b>Springs @ Ground</b> <b>Shock Absorbers</b> <b>Stabilizer Bar</b>	Salisbury Axle, Hypoid Drive; Two-stage Multi-leaf Springs 7900 lb. 4.10 3100 lb. ea. 32mm dia. 1.75" dia.
<b>Brakes</b> <b>Front</b> <b>Rear</b> <b>Booster</b> <b>Parking</b>	Hydraulic; Self-adjusting Disc; 12.5" Rotor Drum; 13" x 3.5" Hydraulic Power Cable to Rear Wheels
<b>Electrical</b> <b>Battery - Freedom Type</b> <b>- Reserve Capacity</b> <b>Delcotron Generator</b> <b>Engine Block Heater</b>	12 Volt; Negative Ground Two; 550 CCA♦ ea. @ 0°F. 115 min. ea. @ 80°F. 66 amp. 600 watts, 120 volts
<b>Frame</b> <b>Section Modulus</b>	Carbon Steel; 36,39,000 psi 125", 137" WB-5.26 158.5" WB-6.12
<b>Fuel Tank (nominal capacity)</b> <b>Permanent</b> <b>Temporary</b>	40 gal. 5 qt.
<b>Steering Gear Type</b> <b>Steering Wheel</b>	Integral Power Comfortilt
<b>Transmission</b> <b>Shift Location</b> <b>Oil Cooler</b>	3-Speed Automatic Steering Column Standard; Integral with Radiator
<b>Tires</b> <b>Front</b> <b>Rear</b>	Tubeless (2) LT215/85R16D (8PR) (4) LT215/85R16C (6PR) (Dual)
<b>Wheels</b>	(6) 16" x 6"

▲Note: Model P31832 not available with diesel engine

♦CCA-Cold Cranking Amps

**GASOLINE**

# MOTOR HOME CHASSIS

Body Ordering Code—ZW9

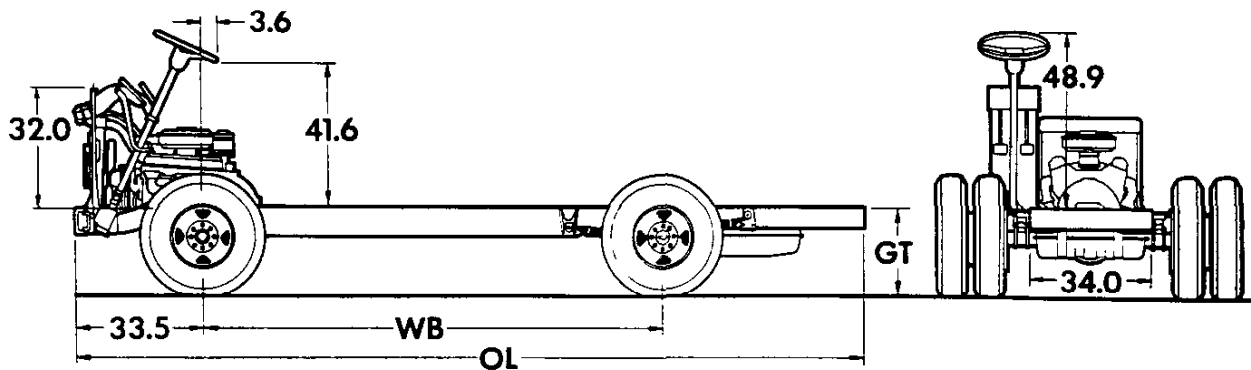

Model	Engine No. Cyl.	Body Length (ft)	Dimensions (in)★			Curb Weights (lb)†			Ground Clearance (in)★	
			WB	OL	GT	Front	Rear	Total	Front	Rear
<b>P30832</b>	8	18-20	125	206.3	27.9	2278	1623	3901	9.2	8
<b>P31132</b>	8	21-23	137	234.3	27.9	2284	1659	3943	9.2	8
<b>P31432</b>	8	24-26	158.5	259.4	27.9	2352	1745	4097	9.2	8
<b>P31832</b>	8	26-28	178	317.3	30.6	2442	2090	4532	10.2	8.9

★Dimensions with standard equipment, unloaded.

†Total Curb Weight may vary as much as  $\pm 50$  lbs. to allow for production build variation.

# MOTOR HOME CHASSIS

**DIESEL**

Body Ordering Code—ZW9/B3J

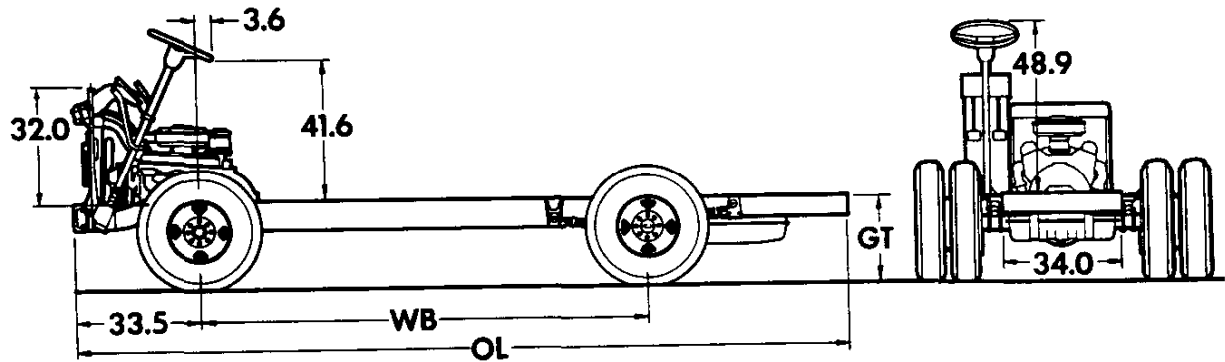

Model	Engine No. Cyl.	Body Length (ft)	Dimensions (in)★			Curb Weights (lb)†			Ground Clearance (in)★	
			WB	OL	GT	Front	Rear	Total	Front	Rear
<b>P30832</b>	8	18-20	125	206.3	27.9	2324	1679	4003	9.2	8
<b>P31132</b>	8	21-23	137	234.3	27.9	2327	1713	4040	9.2	8
<b>P31432</b>	8	24-26	158.5	259.4	27.9	2393	1803	4196	9.2	8

★Dimensions with standard equipment, unloaded.

†Total Curb Weight may vary as much as  $\pm 50$  lbs. to allow for production build variation.

# MOTOR HOME CHASSIS

## POWER TEAMS

### ALL STATES

**POWER TEAMS (MUST ORDER ENGINE, TRANSMISSION AND REAR AXLE)**  
 (Consult GVWR Selector and Tire Chart to insure tire capacity and availability)

**W/NA5 STANDARD (Satisfies High Altitude Emission Requirements)**  
**W/NA6 HIGH ALTITUDE OR YF5 CALIFORNIA EMISSIONS**

ENGINE	TRANSMISSION		AXLES				GVWR
	AUTO		*4.10	4.56	4.88	5.13	
<b>P30832-31132-31432 W/O 7.50-16/D (PE) Tires</b>							
#LE8 V8 7.4 Liter (454-4BBL)	MX1		*GQ1	—	—	—	10500
	MX1		*GQ1	—	—	—	11800
	MX1		—	*HF7	*HF8	—	%14500
■ LL4 Diesel 6.2 Liter V8 (379 Cu. In.)(Reqs B3J)	MX1		*GQ1	—	—	—	10500
	MX1		*GQ1	—	—	—	11800
	MX1		—	—	—	*HC7	%14500
<b>P30832-31132-31432 W/7.50-16/D (PE) Tires</b>							
#LE8 V8 7.4 Liter (454-4BBL)	MX1		*GQ1	HC4	—	—	10500
	MX1		*GQ1	HC4	—	—	11000
	MX1		*GQ1	HC4	—	—	11800
	MX1		*GQ1	HC4	—	—	12300
■ LL4 Diesel 6.2 Liter V8 (379 Cu.in.)(Reqs B3J)	MX1		—	GQ1	—	—	10500
	MX1		—	GQ1	—	—	11000
	MX1		—	GQ1	—	—	11800
	MX1		—	GQ1	—	—	12300
<b>P31832</b>							
#LE8 V8 7.4 Liter (454-4BBL)	MX1		—	GQ1	HF8	—	14500

\*N/A G80 Locking Differential

%CP31432 only

#N/A NA6 High Altitude Emissions. With NA5 Emissions  
 Satisfies High Altitude Requirements

■ High Altitude Emission Equipment (FOR EXHAUST SMOKE REDUCTION PURPOSES  
 AT HIGH ALTITUDE; NOT REQUIRED TO SATISFY HIGH ALTITUDE EMISSION REGULATIONS).

## ENGINE RATINGS

### ALL STATES EXCEPT CALIFORNIA

SAE Net Ratings	7.4 Liter 454 4-bbl V8	6.2 Liter 379 V8 Diesel
Net Horsepower.....	230 @ 3800 rpm	135 @ 3600 rpm
Net Torque, lb-ft.....	360 @ 2800 rpm	240 @ 2000 rpm

### CALIFORNIA ONLY

SAE Net Ratings	7.4 Liter 454 4-bbl V8	6.2 Liter 379 V8 Diesel
Net Horsepower.....	230 @ 3800 rpm	135 @ 3600 rpm
Net Torque, lb-ft.....	360 @ 2800 rpm	240 @ 2000 rpm

# MOTOR HOME CHASSIS

## GVWR SELECTOR—ALL STATES

GVW Rating (lbs)	†GAWR (lbs)		Minimum Equipment Required for GVW Rating		
	Front	Rear	Tire Capacity (lbs ea)		Chassis Equipment
			Front	Rear	
<b>125", 137", 158.5" WB Models</b>					
10,500	4300	6200	2315	1764	Standard
11,000	4880	6200	2440	2140	HD Front Suspension (F66)
11,800	4300	7500	2315	2105	HD Rear Springs (G50)
12,300	4880	7500	2440	2140	HD Front Suspension (F66); HD Rear Springs (G50)
●14,500	5000	9840	2800	2460	10,000-lb Rear Axle (HC7/HF7/HF8)
<b>178" WB Model</b>					
14,500	5000	9840	2800	2460	Standard

†GAWR's shown are the maximum for each axle with equipment listed. Other GAWR's are available, and they are determined as the minimum capacity of either axle, springs or tires.

●Available on 158.5" WB model only.

## FRONT AND REAR TIRE AVAILABILITY CHART—ALL STATES

Spare tire to match either front or rear tires available at extra cost

Description	Capacity (lbs each)		Highway		Spare
	Front	Dual Rear	Front	Dual Rear	
<b>125", 137", 158.5" WB Models</b>					
<b>TUBELESS</b>					
<b>LT215/85R16D</b> Steel Belted Radial	2315	2105	XYK	YYK	ZYK
<b>LT215/85R16C</b> Steel Belted Radial	—	1764	—	YYJ	ZYK
<b>157.5", 178" WB Models</b>					
<b>TUBELESS</b>					
<b>*8-19.5D</b> Polyester	2800	2460	XSN	YSN	ZSN
<b>125", 137", 158.5" WB Models</b>					
<b>TUBE-TYPE</b>					
<b>7.50-16D</b> Polyester	2440	2140	XPE	YPE	ZPE

\*Requires 10,000 lb. rear axle (HC7, HF7 or HF8) on 158.5" WB model.



## **MOTOR HOME CHASSIS**

### **THE FOLLOWING EQUIPMENT IS STANDARD ON DIESEL ENGINE MODELS (ALSO SEE STANDARD SPECIFICATIONS PAGES)**

- Low Coolant Sensor
- Poly-wrapped Paper Element Air Cleaner
- Power Steering
- Engine Block Heater
- Water/fuel separator unit which incorporates a water sensor and sending unit, a fuel filter, a fuel heater and water drain capability
- Dual 550 Cold Cranking Amp/115 min. Reserve Capacity Batteries
- HD Radiator
- Dual Exhaust System
- Warning Lights: Glow Plugs, Water-in-fuel (or fuel filter), and Low Coolant
- Diesel Engine Identification:
  - Nameplates
  - "Diesel Fuel Only" filler cap and label

# MOTOR HOME CHASSIS (10,500-lb - 14,500-lb GVW)

## 1984 VEHICLES WITH STANDARD EQUIPMENT

Prices shown are effective with vehicles produced on and after February 13, 1984

Description	Model Number	Body Code	Wheel Base	Factory D&H(a)	List Price	Mfr's Suggested Retail Price*	Group Number
<b>◆ 8 Cylinder 7.4 Liter (454 Cu. In.) 4 BBL V8 Gasoline Engine-Engine Ordering Code LE8</b>							
Motor Home Chassis . . . . .	CP/TP30832	ZW9	125"	.40	8889.00	8889.40	14
Motor Home Chassis . . . . .	CP/TP31132	ZW9	137"	.40	8973.00	8973.40	14
Motor Home Chassis . . . . .	CP/TP31432	ZW9	158.5"	.40	9119.00	9119.40	14
Motor Home Chassis . . . . .	CP/TP31832	ZW9	178"	6.54	10399.00	10405.54	14
<b>◆ 8-Cylinder 6.2 Liter (379 Cu. In.) H.D. Diesel V8 Engine-Engine Ordering Code LL4</b>							
Motor Home Chassis . . . . .	CP/TP30832	ZW9 & B3J	125"	.40	10620.00	10620.40	14
Motor Home Chassis . . . . .	CP/TP31132	ZW9 & B3J	137"	.40	10703.00	10703.40	14
Motor Home Chassis . . . . .	CP/TP31432	ZW9 & B3J	158.5"	.40	10848.00	10848.40	14

★ Manufacturer's Suggested Retail Prices do not include applicable destination charges, state and local taxes, license fees, optional equipment or accessories or special items or services.

◆ Refer to Dealer Order Guide for California Requirements.

### OPTIONS AND ACCESSORIES WHEN INSTALLED BY GENERAL MOTORS

Prices shown are effective with vehicles produced on and after February 13, 1984

Description	Option Number	Factory D&H(a)	List Price	Mfr's Suggested Retail Price◇
<b>Emission Systems:</b> Dealer Note - One of the following emission options must be specified.				
<i>California Emission Requirements:</i> Includes all testing, equipment and/or certification necessary for registration in the State of California. See Power Teams Chart for availability and complete specifications.				
Without B3J Diesel Equipment . . . . .	YF5	N.A.	235.00	235.00
With B3J Diesel Equipment . . . . .	YF5	N.A.	235.00	235.00
<i>High Altitude Emission Equipment.</i> Available only when B3J Diesel Equipment is specified. Not available when YF5 California Emission Requirements or NA5 Standard Emission Equipment is specified. . . . .				
	NA6	NO ADDITIONAL CHARGE		
<i>Standard Emissions Equipment.</i> Not available when YF5 California or NA6 High Altitude Emissions is specified . . . . .				
	NA5	NO ADDITIONAL CHARGE		
<b>Engines:</b> (See Power Teams Chart for availability and complete specifications)				
Gasoline.				
7.4 Liter (454 Cu. In.) 4 BBL V8. . . . .	LE8	NO ADDITIONAL CHARGE		
Diesel				
6.2 Liter (379 Cu. In.) H.D. V8 Diesel. Available only when B3J Diesel Equipment is specified. Not available on P31832 . . . . .				
	LL4	NO ADDITIONAL CHARGE		
<b>Transmission:</b> 3-Speed Automatic . . . . .				
	MX1	NO ADDITIONAL CHARGE		
<b>Axles, Rear:</b> (See Power Teams Chart for option number selection, availability and complete specifications)				
<i>Optional Ratio.</i> . . . . .				
		N.A.	36.00	36.00
<i>Capacity 10,000-lb. Heavy Duty.</i> P31432 available only when SN 8-19.5 Tires are specified. Not available on P30832 or P31132. Includes H.D. power 4-wheel disc brakes, 5000-lb capacity Positrim front suspension, 10,000-lb capacity rear springs and propeller shaft mounted parking brake.				
4.56 Ratio. Standard on 178" wheelbase. Not available when B3J Diesel Equipment is specified . . . . .	HF7	N.A.	1502.00	1502.00
4.88 Ratio. Not available when B3J Diesel Equipment is specified.				
158.5" wheelbase only . . . . .	HF8	N.A.	1502.00	1502.00
178" wheelbase only . . . . .	HF8	N.A.	36.00	36.00
5.13 Ratio. P31432 only. Available only when B3J Diesel Equipment is specified. . . . .	HC7	N.A.	1502.00	1502.00
Locking Differential. Not available on 178" wheelbase . . . . .	G80	N.A.	230.00	230.00

(a) D & H Charges on vehicle and optional equipment include reimbursement to ordering Division for any tax that it has paid, incurred or agreed to pay thereon.

◇ State and local taxes not included.

# MOTOR HOME CHASSIS

## OPTIONS AND ACCESSORIES WHEN INSTALLED BY GENERAL MOTORS

Prices shown are effective with vehicles produced on and after February 13, 1984

Description	Option Number	Factory D&H(a)	List Price	Mfr's Suggested Retail Price◇
<b>Tires:</b>				
TUBELESS P30832, P31132 or P31432 only.				
All rim sizes are 6.00"				
<b>LT215/85R16-C Steel Belted Highway Radial Blackwall</b>				
(Maximum Capacity Each. Dual Rear 1764-lbs)				
Rear. (Standard)	YYJ		NO ADDITIONAL CHARGE	
<b>LT215/85R16-D Steel Belted Highway Radial Blackwall</b>				
(Maximum Capacity Each. Front 2315-lbs) (Dual Rear 2105-lbs)				
Front. (Standard)	XYK		NO ADDITIONAL CHARGE	
Rear	YYK	.20	64.00	64.20
Spare	ZYK	.10	310.00	310.10
TUBELESS. P31432 or P31832 only. All 8-19.5 tires on P31432 available only when HC7, HF7 or HF8 10,000-lb Rear Axle is specified.				
<b>8-19.5/D Highway Polyester Blackwall</b>				
(Maximum Capacity Each. Front 2800-lbs) (Dual Rear 2460-lbs)				
Front				
P31432 only	XSN	1.98	(-96.00)	(-94.02)
P31832 only. (Standard)	XSN		NO ADDITIONAL CHARGE	
Rear				
P31432 only	YSN	4.16	(-128.00)	(-123.84)
P31832 only. (Standard)	YSN		NO ADDITIONAL CHARGE	
Spare	ZSN	1.09	262.00	263.09
TUBE-TYPE. P30832, P31132 or P31432.				
<b>7.50-16/D Highway Polyester Blackwall</b>				
(Maximum Capacity Each. Front 2440-lbs) (Dual Rear 2140-lbs)				
Front	XPE	(-.20)	(-176.00)	(-176.20)
Rear	YPE	(-.20)	(-288.00)	(-288.20)
Spare	ZPE		N.C.	222.00

### OTHER OPTIONS

<b>Heater, Engine Block:</b> 600 watts, 120 volts. Not available when B3J Diesel Equipment is specified	K05		31.00	31.00
<b>Preliminary Price Information</b>	B3W		N.A.	N.A.
<b>Springs:</b> Rear, Heavy-Duty. Capacity 3750-lb each. Available only when YK LT215/85R16D or PE 7.50-16 Rear Tires are specified. Not available on 178" wheelbase or when HC7, HF7 or HF8 10,000-lb Rear Axle is specified	G50		55.00	55.00
<b>Suspension:</b> Positrim. Front, Heavy-Duty. Available only when PE 7.50-16 Tires are specified. Not available on 178" wheelbase or when HC7, HF7 or HF8 10,000-lb Rear Axle is specified.	F66		478.00	478.00
<b>Wheel, Spare:</b> 19.5" x 6.00". P31432 or P31832 only. Available only when SN 8-19.5/D Tires are specified	Q34		75.00	75.00

(a) D & H Charges on vehicle and optional equipment include reimbursement to ordering Division for any tax that it has paid, incurred or agreed to pay thereon.  
 ◇ State and local taxes not included.

# **MOTOR HOME CHASSIS**

## **CHASSIS FEATURES**

# MOTOR HOME CHASSIS

## EXTERIOR FEATURES—STANDARD MODELS

The Standard models include the following items as standard equipment.

- **Color:** Chassis and components painted black
- **Emblem:** Bright Chevrolet/GMC letters (Furnished loose in parts box)
- **Front Frame Member:** Heavy channel reinforcement; painted black
- **Horn:** Single; low note; electric
- **Instruments:**
  - Gages: Speedometer, odometer, voltmeter, oil pressure, engine temperature and fuel
  - Switches: Main, for control of exterior lights and instrument lights; headlight beam (foot); ignition, direction signal with lane change position; and hazard warning
  - Warning lamps: service-parking brake, direction/hazard signal and high beam
  - NOTE: Ignition, direction signal, and hazard warning switches are installed; all other gages, switches and warning lamps are furnished loose in parts box*
- **Lights:** (Furnished loose in parts box)
  - Combination parking/direction/hazard
  - Headlamps: Two; Power Beam
- **Steering Wheel:** Six-position Comfortilt type; 16" diameter; 2-spoke, black soft vinyl
- **Tilt Steering Column:** Lever adjusting control (Six-position)
- **Wheels:** Painted white

## MOTOR HOME CHASSIS

125" WB

137" WB

158.5" WB

178" WB

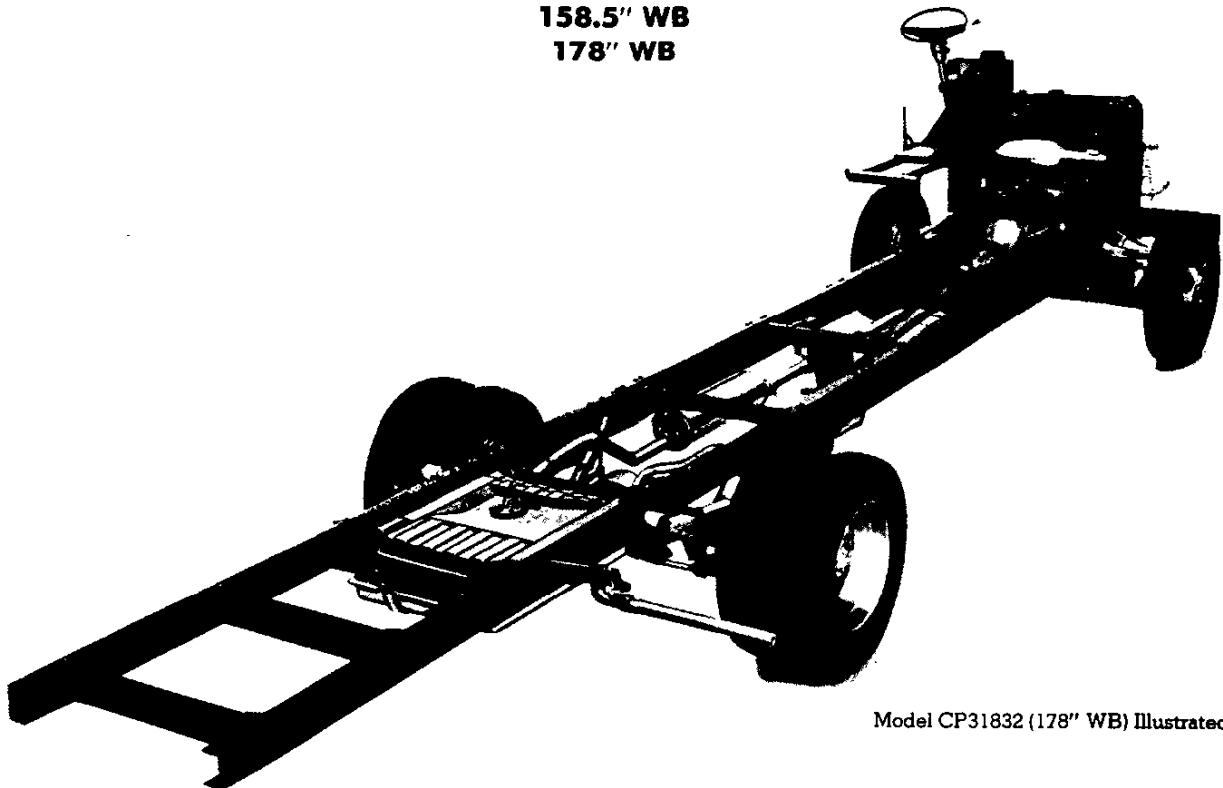

Model CP31832 (178" WB) Illustrated

## CUTAWAY VAN

### RALLY CAMPER SPECIAL & VANDURA SPECIAL

CUTAWAY VAN, VANDURA SPECIAL & RALLY CAMPER SPECIAL MODEL SELECTOR

★RV Cutaway Van & Rally Camper Special models, G31332 and G31632, are for recreational vehicle use only and are not to be used for the mounting of any type commercial body.

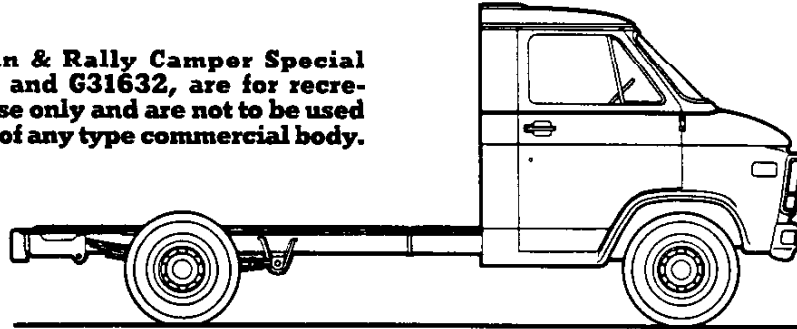

SERIES	MODEL NUMBER		BODY ORDERING CODE			
			GASOLINE MODELS		DIESEL MODELS	
	125" WB	146" WB	COMMERCIAL CUTAWAY VAN/ VANDURA SPECIAL	★RV CUTAWAY VAN/RALLY CAMPER SPECIAL	COMMERCIAL CUTAWAY VAN/ VANDURA SPECIAL	★RV CUTAWAY VAN/RALLY CAMPER SPECIAL
G30/3500	G31303	G31603	ZW9	—	ZW9/B3J	—
	G31332★	G31632★	—	ZW9	—	ZW9/B3J
G30/3500/ C7C	—	G31603	ZW9/C7C	—	ZW9/B3J/C7C	—

## HI-CUBE VAN/MAGNAVAN

### HI-CUBE VAN/MAGNAVAN MODEL SELECTOR

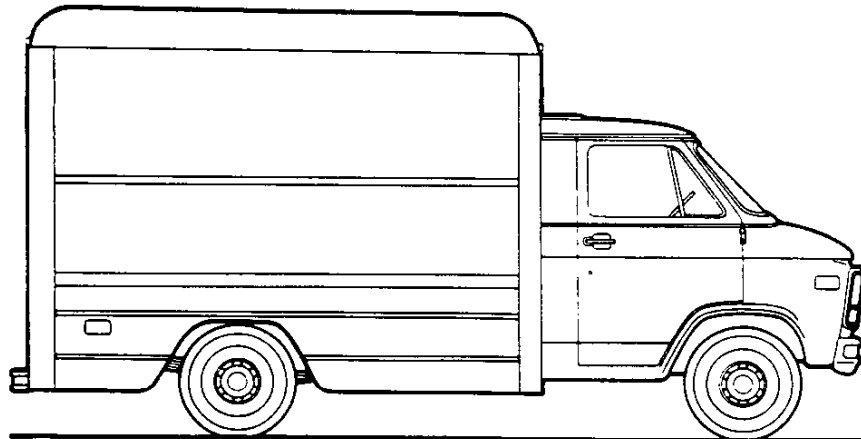

SERIES	MODEL NUMBER		BODY ORDERING CODE			
			STEEL		ALUMINUM	
	125" WB	146" WB	10' BODY	12' BODY	10' BODY	12' BODY
<b>GASOLINE MODELS</b>						
G30/3500	G31303	—	E31 (96" wide) E34 (82.5" wide)	—	E36	—
	—	G31603	—	E38	—	E39
<b>DIESEL MODELS</b>						
G30/3500	G31303	—	E31/B3J (96" wide) E34/B3J (82.5" wide)	—	E36/B3J	—
	—	G31603	—	E38/B3J	—	E39/B3J

# CUTAWAY VAN

## RALLY CAMPER SPECIAL & VANDURA SPECIAL

### STANDARD SPECIFICATIONS

**GASOLINE**

(See Gray Tab Section for Specification Details)

Model	G31303	G31332*	G31603	G31632*
<b>Engine</b>	5.7 Liter, 350 4-bbl. V8			
<b>Base Equip.</b>	Oiled-paper Element			
<b>Air Filter</b>	Throwaway Type			
<b>Oil Filter</b>	*Single; Aluminized			
<b>Exhaust System</b>	See Engine & Cooling Section for specific model applications			
<b>Emission Control Systems</b>				
<b>Suspension, Front</b>	Independent; Coil Springs			
<b>Capacity</b>	3900 lb.			
<b>Springs @ Ground</b>	1700 lb. ea.		1950 lb. ea.	
<b>Shock Absorbers</b>	25mm dia.		35mm dia.	
<b>Stabilizer Bar</b>	—		1.06" dia.	
<b>Suspension, Rear</b>	Salisbury Axle; Hypoid Drive; Two-stage Multi-leaf Springs			
<b>Axle Capacity</b>	5700 lb.		▲6200 lb.	7500 lb.
<b>Axle Ratio</b>	3.23	4.10	▲4.10	4.56
<b>Springs @ Ground</b>	2100 lb. ea.	3000 lb. ea.	3600 lb. ea.	
<b>Shock Absorbers</b>	25mm dia.		35mm dia.	
<b>Brakes</b>	Hydraulic; Self-adjusting			
<b>Front</b>	Disc; 12.5" Rotor			
<b>Rear</b>	Drum; 13" x 2.5"		Drum; 13" x 3.5"	
<b>Booster</b>	Dual Diaphragm		Hydro-Boost	
<b>Parking</b>	Cable to Rear Wheels			
<b>Electrical</b>	12 Volt; Negative Ground			
<b>Battery</b>	390 CCA♦ @ 0°F.		515 CCA♦ @ 0°F.	
<b>— Freedom Type</b>	90 min. @ 80°F.		115 min. @ 80°F.	
<b>— Reserve Capacity</b>	37 amp		66 amp	
<b>Delcotron Generator</b>				
<b>Frame</b>	Integral Body-frame			
<b>Fuel Tank (nominal capacity)</b>	22 gal.	33 gal.	22 gal.	33 gal.
<b>Steering</b>	Integral Power			
<b>Transmission</b>	3-Speed Automatic			
<b>Shift Location</b>	Steering Column			
<b>Oil Cooler</b>	Standard			
<b>Tires</b>	(4)8.75-16.5D(8PR)	(4)8.75-16.5E(10PR)	▲(6)8.00-16.5C(6PR)	(6)8.00-16.5D(8PR)
	(Single Rear)		(Dual Rear)	(Dual Rear)
<b>Wheels</b>	(4) 16.5" x 6.75"		(6) 16.5" x 6.0"	

•RV Cutaway Van models, G31332 and G31632, are for recreational vehicle use only and are not to be used for the mounting of any type commercial body.

\*Dual tailpipe on all models.

♦CCA-Cold Cranking Amps

■7500-lb rear axle with 4.56 ratio standard on G31603 with C7C.

▲(6)8.00-16.5D(8PR) tires standard on G31603 with C7C.

# CUTAWAY VAN

## RALLY CAMPER SPECIAL & VANDURA SPECIAL

### STANDARD SPECIFICATIONS

(See Gray Tab Section for Specification Details)

**DIESEL**

Model	G31303	G31332*	G31603	G31632*
<b>Engine</b>	6.2 Liter, 379 Cu. In. V8 Diesel			
<b>Base Equip.</b> .....	Poly-wrapped, Oiled-paper Element			
<b>Air Filter</b> .....	Throwaway Type			
<b>Oil Filter</b> .....	Standard			
<b>Oil Cooler</b> .....	Dual; Aluminized			
<b>Exhaust System</b> .....	See Engine & Cooling Section for specific model applications			
<b>Emission Control Systems</b> .....				
<b>Suspension, Front</b> .....	Independent; Coil Springs			
<b>Capacity</b> .....	3900 lb.			
<b>Springs @ Ground</b> .....	1700 lb. ea.		1950 lb. ea.	
<b>Shock Absorbers</b> .....	25mm dia.		35mm dia.	
<b>Stabilizer Bar</b> .....	—		1.06" dia.	
<b>Suspension, Rear</b> .....	Salisbury Axle; Hypoid Drive; Two-stage Multi-leaf Springs			
<b>Axle Capacity</b> .....	5700 lb.		■6200 lb.	7500 lb.
<b>Axle Ratio</b> .....	3.23	4.10	■4.10	4.56
<b>Springs @ Ground</b> .....	2100 lb. ea.	3000 lb. ea.	3600 lb. ea.	
<b>Shock Absorbers</b> .....	25mm dia.		35mm dia.	
<b>Brakes</b> .....	Hydraulic; Self-adjusting			
<b>Front</b> .....	Disc; 12.5" Rotor			
<b>Rear</b> .....	Drum; 13" x 2.5"		Drum; 13" x 3.5"	
<b>Booster</b> .....	Hydraulic Power			
<b>Parking</b> .....	Cable to Rear Wheels			
<b>Electrical</b> .....	12 Volt; Negative Ground			
<b>Battery</b> .....	Two; 550 CCA ♦ ea. @ 0°F.			
<b>— Freedom Type</b> .....	115 min. ea. @ 80°F.			
<b>— Reserve Capacity</b> .....	66 amp.			
<b>Delcotron Generator</b> .....	600 watts, 120 volts			
<b>Engine Block Heater</b> .....				
<b>Frame</b> .....	Integral Body-frame			
<b>Fuel Tank (nominal capacity)</b> .....	22 gal.	33 gal.	22 gal.	33 gal.
<b>Steering</b> .....	Integral Power			
<b>Transmission</b> .....	3-Speed Automatic			
<b>Shift Location</b> .....	Steering Column			
<b>Oil Cooler</b> .....	Standard			
<b>Tires</b> .....	(4)8.75-16.5D(8PR)	(4)8.75-16.5E(10PR)	▲(6)8.00-16.5C(6PR)	(6)8.00-16.5D(8PR)
	(Single Rear)		(Dual Rear)	(Dual Rear)
<b>Wheels</b> .....	(4) 16.5" x 6.75"		(6) 16.5" x 6.0"	

•RV Cutaway Van models, G31332 and G31632, are for recreational vehicle use only and are not to be used for the mounting of any type commercial body.

♦CCA-Cold Cranking Amps

■7500-lb rear axle with 4.56 ratio standard on G31603 with C7C.

▲(6)8.00-16.5D(8PR) tires standard on G31603 with C7C.



**GASOLINE**

# HI-CUBE VAN/MAGNAVAN

## STANDARD SPECIFICATIONS

(See Gray Tab Section for Specification Details)

Model	G31303		G31603	
	E34-10' Steel	E31-10' Steel E36-10' Aluminum	E38-12' Steel	E39-12' Aluminum
<b>Engine</b>	5.7 Liter, 350 4-bbl. V8 Oiled-paper Element Throwaway Type *Single; Aluminized  See Engine & Cooling Section for specific model applications			
Base Equip. ....				
Air Filter .....				
Oil Filter .....				
Exhaust System .....				
Emission Control System .....	See Engine & Cooling Section for specific model applications			
<b>Suspension, Front</b>	Independent; Coil Springs			
Capacity .....	3900 lb.			
Springs @ Ground .....	1700 lb. ea.		1950 lb. ea.	
Shock Absorbers .....	25mm dia.		35mm dia.	
Stabilizer Bar .....	—		1.06" dia.	
<b>Suspension, Rear</b>	Salisbury Axle; Hypoid Drive; Two-stage Multi-leaf Springs			
Axle Capacity .....	5700 lb.		6200 lb.	
Axle Ratio .....	3.23	4.10	4.10	
Springs @ Ground .....	2100 lb. ea.	3000 lb. ea.	3600 lb. ea.	
Shock Absorbers .....	25mm dia.		35mm dia.	
<b>Brakes</b>	Hydraulic; Self-adjusting			
Front .....	Disc; 12.5" Rotor			
Rear .....	Drum; 13" x 2.5"		Drum; 13" x 3.5"	
Booster .....	Dual Diaphragm		Hydro-Boost	
Parking .....	Cable to Rear Wheels			
<b>Electrical</b>	12 Volt; Negative Ground			
Battery .....	390 CCA ♦ @ 0°F.		515 CCA ♦ @ 0°F.	
— Freedom Type .....	90 min. @ 80°F.		115 min. @ 80°F.	
— Reserve Capacity .....	37 amp.		66 amp.	
Delcotron Generator .....				
<b>Frame</b> .....	Integral Body-frame			
<b>Fuel Tank (nominal capacity)</b> .....	22 gal.			
<b>Steering</b> .....	Integral Power			
<b>Transmission</b>	3-Speed Automatic			
Shift Location .....	Steering Column			
Oil Cooler .....	Standard			
<b>Tires</b> .....	(4) 8.75-16.5D (8PR) (Single Rear)		(6) 8.00-16.5C (6PR) (Dual Rear)	
<b>Wheels</b> .....	(4) 16.5" x 6.75"		(6) 16.5" x 6.0"	

\*Dual tailpipe on all models  
♦CCA-Cold Cranking Amps

# HI-CUBE VAN/MAGNAVAN

**DIESEL**

## STANDARD SPECIFICATIONS

(See Gray Tab Section for Specification Details)

Model	G31303		G31603	
Body Ordering Code	E34-10' Steel	E31-10' Steel E36-10' Aluminum	E38-12' Steel	E39-12' Aluminum
<b>Engine</b>	6.2 Liter, 379 Cu. In. V8 Diesel Poly-wrapped, Oiled-paper Element Thruaway Type Standard Dual; Aluminized  See Engine & Cooling Section for specific model applications			
Base Equip. ....				
Air Filter .....				
Oil Filter .....				
Oil Cooler .....				
Exhaust System .....	See Engine & Cooling Section for specific model applications			
Emission Control System .....	See Engine & Cooling Section for specific model applications			
<b>Suspension, Front</b>	Independent; Coil Springs			
Capacity .....	3900 lb.			
Springs @ Ground .....	1700 lb. ea.		1950 lb. ea.	
Shock Absorbers .....	25mm dia.		35mm dia.	
Stabilizer Bar .....	— 1.06" dia.			
<b>Suspension, Rear</b>	Salisbury Axle; Hypoid Drive; Two-stage Multi-leaf Springs			
Axle Capacity .....	5700 lb.		6200 lb.	
Axle Ratio .....	3.23		4.10	
Springs @ Ground .....	2100 lb. ea.		3600 lb. ea.	
Shock Absorbers .....	25mm dia.		35mm dia.	
<b>Brakes</b>	Hydraulic; Self-adjusting			
Front .....	Disc; 12.5" Rotor			
Rear .....	Drum; 13" x 2.5"	Drum; 13" x 3.5"		
Booster .....	Hydraulic Power			
Parking .....	Cable to Rear Wheels			
<b>Electrical</b>	12 Volt; Negative Ground			
Battery .....	Two; 550 CCA ♦ ea. @ 0°F.			
— Freedom Type .....	115 min. ea. @ 80°F.			
— Reserve Capacity .....	66 amp.			
Delcotron Generator .....	600 watts, 120 volts			
Engine Block Heater .....				
<b>Frame</b>	Integral Body-frame			
<b>Fuel Tank (nominal capacity)</b>	22 gal.			
<b>Steering</b>	Integral Power			
<b>Transmission</b>	3-Speed Automatic			
Shift Location .....	Steering Column			
Oil Cooler .....	Standard			
<b>Tires</b>	(4) 8.75-16.5D (8PR) (Single Rear)		(6) 8.00-16.5C (6PR) (Dual Rear)	
<b>Wheels</b>	(4) 16.5" x 6.75"		(6) 16.5" x 6.0"	

♦CCA-Cold Cranking Amps

# CUTAWAY VAN RALLY CAMPER SPECIAL & VANDURA SPECIAL

Body Ordering Code—ZW9

**GASOLINE**

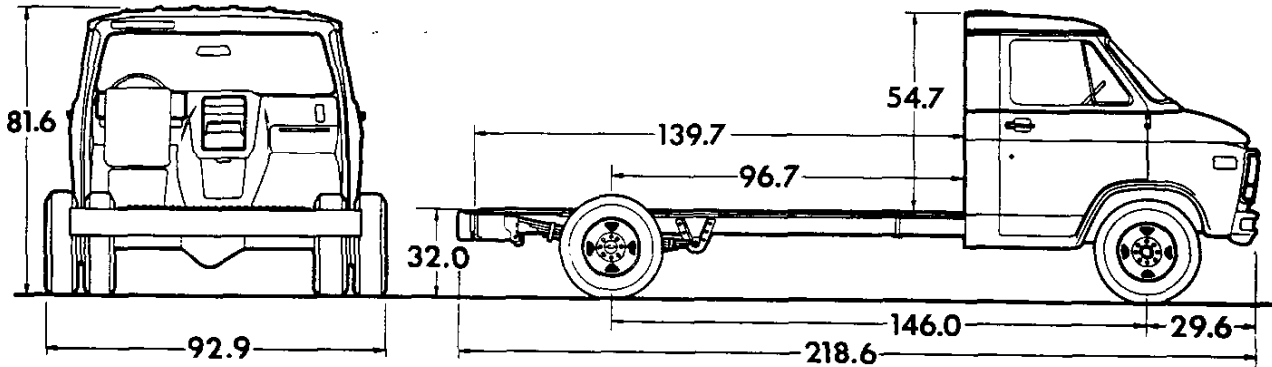
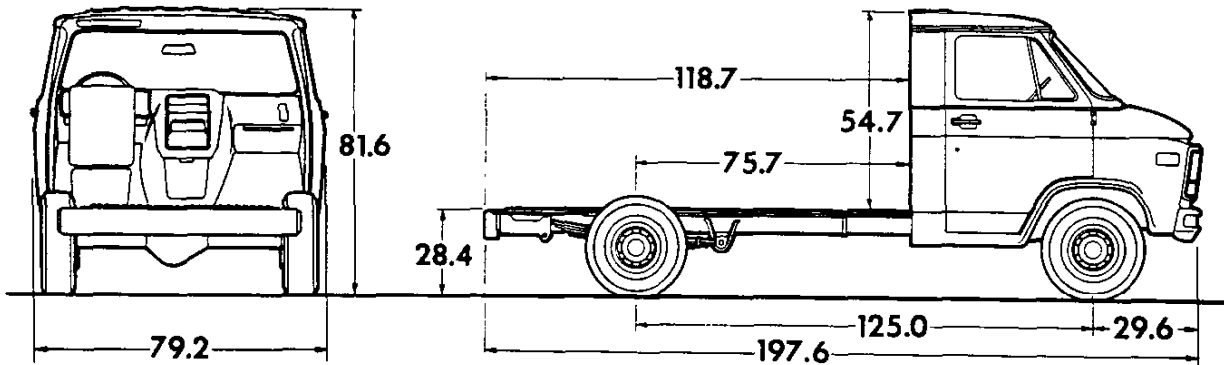

**Ground Clearance (in)★** — Front 9.0 in.; Rear 7.0 in.

Model	Engine No. Cyl.	Dimensions (in)★			Curb Weight (lb)			Model Weight (lb)*		
		WB	OL	OH	Front	Rear	Total	Front	Rear	Total
<b>G31303</b>	8	125	197.6	81.6	2386	1345	3731	2497	1384	3881
● <b>G31332</b>		125	197.6	81.6	2402	1503	3905	2513	1542	4055
<b>G31603</b>	8	146	218.6	81.6	2582	1589	4171	2699	1622	4321
<b>G31603 (w/C7C)</b>		146	218.6	81.6	2609	1656	4265	2726	1689	4415
● <b>G31632</b>		146	218.6	81.6	2588	1731	4319	2705	1764	4469

★ Dimensions with standard equipment, unloaded.

\*Model Weight includes Curb Weight plus occupants (standard seating capacity x 150 lb). Total Model Weight may vary as much as ±50 lbs. to allow for production build variation.

● RV Cutaway Van models, G31332 and G31632, are for recreational vehicle use only and are not to be used for the mounting of any type commercial body.

# CUTAWAY VAN RALLY CAMPER SPECIAL & VANDURA SPECIAL

Body Ordering Code—ZW9/B3J

**DIESEL**

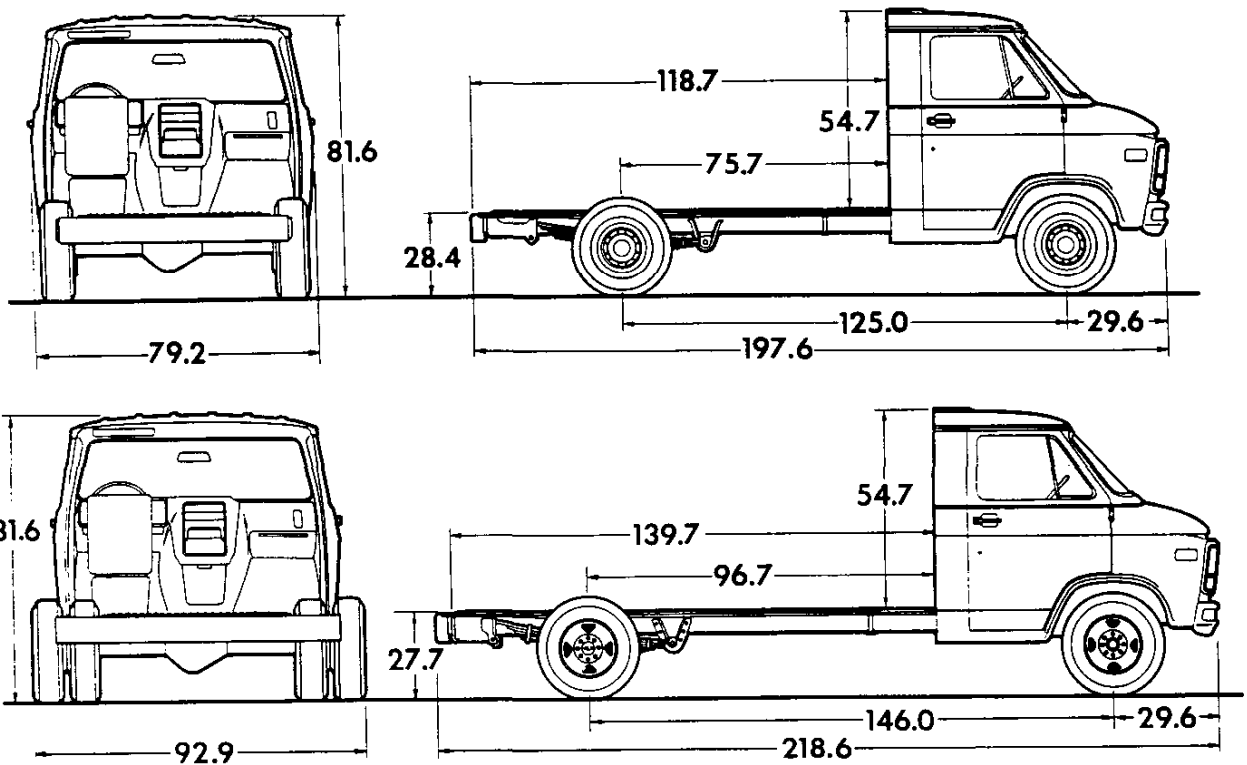

**Ground Clearance (in)★** — Front 9.0 in.; Rear 7.0 in.

Model	Engine No. Cyl.	Dimensions (in)★			Curb Weight (lb)			Model Weight (lb)*		
		WB	OL	OH	Front	Rear	Total	Front	Rear	Total
<b>G31303</b>	8	125	197.6	81.6	2687	1414	4101	2798	1453	4251
● <b>G31332</b>		125	197.6	81.6	2690	1575	4265	2801	1614	4415
<b>G31603</b>	8	146	218.6	81.6	2879	1658	4537	2996	1691	4687
<b>G31603 (w/C7C)</b>		146	218.6	81.6	2906	1725	4631	3023	1758	4781
● <b>G31632</b>		146	218.6	81.6	2872	1803	4675	2989	1836	4825

★ Dimensions with standard equipment, unloaded.

\*Model Weight includes Curb Weight plus occupants (standard seating capacity x 150 lb). Total Model Weight may vary as much as ±50 lbs. to allow for production build variation.

● RV Cutaway Van models, G31332 and G31632, are for recreational vehicle use only and are not to be used for the mounting of any type commercial body.

**GASOLINE**

# HI-CUBE VAN/MAGNAVAN

**Body Ordering Codes:**

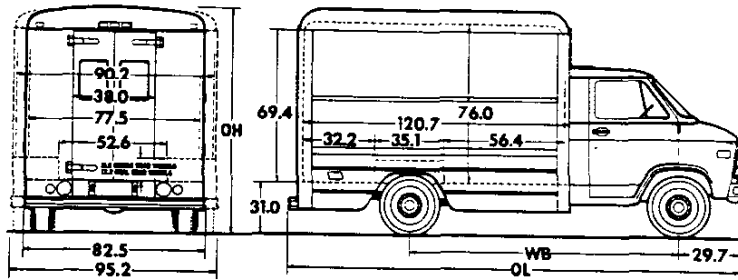

**10' Steel Body—E31 (95" wide)**

**10' Steel Body—E34 (82.5" wide)**

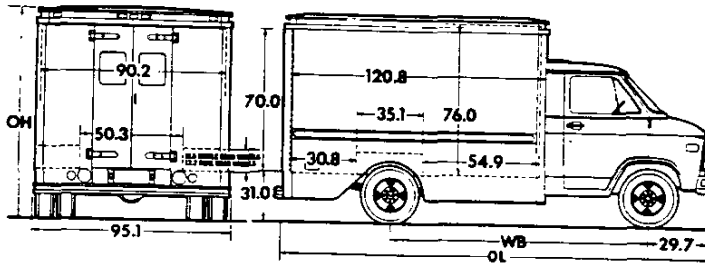

**10' Aluminum Body—E36**

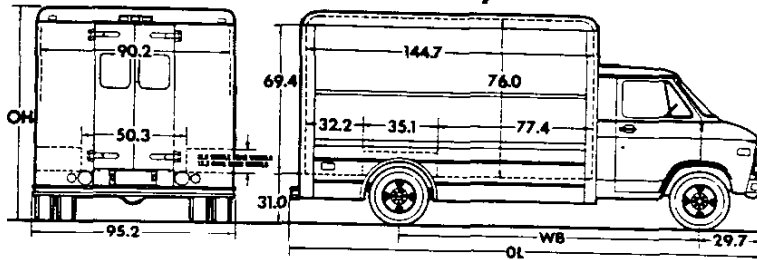

**12' Steel Body—E38**

**12' Aluminum Body—E39**

**See pages 10-11 for additional dimensional information**

**Ground Clearance (in.)★—Front 9.0 in; Rear 7.0 in.**

Model	Engine No. Cyl.	Body Ordering Code	Dimensions (in)★			Curb Weight (lb)			Model Weight (lb)*		
			WB	OL	OH	Front	Rear	Total	Front	Rear	Total
<b>G31303</b>	8	<b>E31</b> (10' Steel)	125	211.0	109.8	2674	2749	5423	2785	2788	5573
		<b>E34</b> (10' Steel)	125	211.0	109.8	2553	2501	5054	2664	2540	5204
		<b>E36</b> (10' Alum.)	125	214.0	109.5	2609	2339	4948	2720	2378	5098
<b>G31603</b>	8	<b>E38</b> (12' Steel)	146	235.0	109.8	2880	3011	5891	2997	3044	6041
		<b>E39</b> (12' Alum.)	146	238.0	109.5	2773	2560	5333	2890	2593	5483

★Dimensions with standard equipment, unloaded.

\*Model Weight includes Curb Weight plus occupants (standard seating capacity x 150 lb.). Total Model Weight may vary as much as ±50 lbs. to allow for production build variation.

# HI-CUBE VAN/MAGNAVAN

Body Ordering Codes:

**DIESEL**

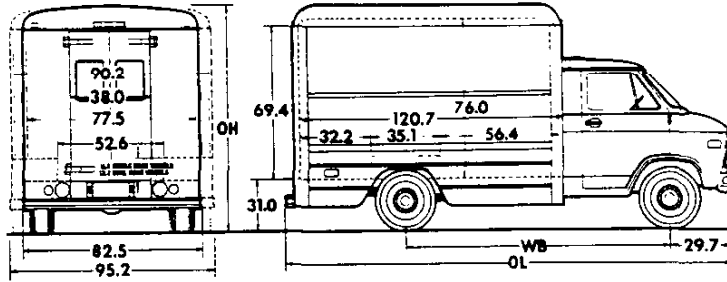

**10' Steel Body—E31/B3J (95" wide)**

**10' Steel Body—E34/B3J (82.5" wide)**

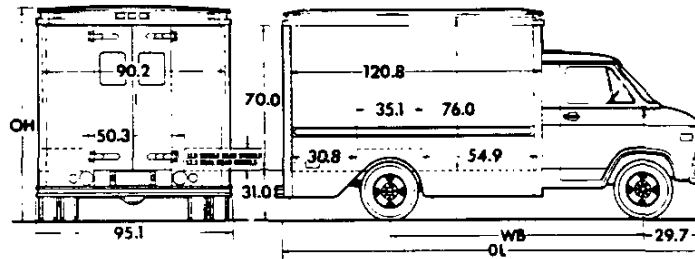

**10' Aluminum Body—E36/B3J**

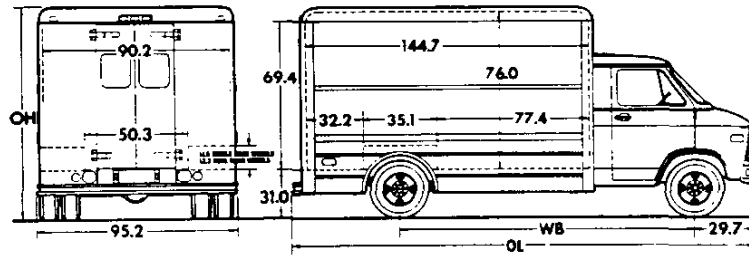

**12' Steel Body—E38/B3J**

**12' Aluminum Body—E39/B3J**

See pages 10-11 for additional dimensional information

Ground Clearance (in.)★—Front 9.0 in; Rear 7.0 in.

Model	Engine No. Cyl.	Body Ordering Code	Dimensions (in)★			Curb Weight (lb)			Model Weight (lb)*		
			WB	OL	OH	Front	Rear	Total	Front	Rear	Total
G31303	8	E31/B3J (10' Steel)	125	211.0	109.8	2999	2837	5836	3110	2876	5986
		E34/B3J (10' Steel)	125	211.0	109.8	2854	2570	5424	2965	2609	5574
		E36/B3J (10' Alum.)	125	214.0	109.5	2934	2427	5361	3045	2466	5511
G31603	8	E38/B3J (12' Steel)	146	235.0	109.8	3177	3080	6257	3294	3113	6407
		E39/B3J (12' Alum.)	146	238.0	109.5	3070	2629	5699	3187	2662	5849

★Dimensions with standard equipment, unloaded.

\*Model Weight includes Curb Weight plus occupants (standard seating capacity x 150 lb.). Total Model Weight may vary as much as ±50 lbs. to allow for production build variation.

# HI-CUBE VAN/MAGNAVAN

## STEEL BODIES DIMENSIONS

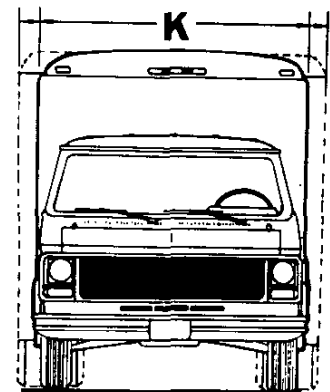
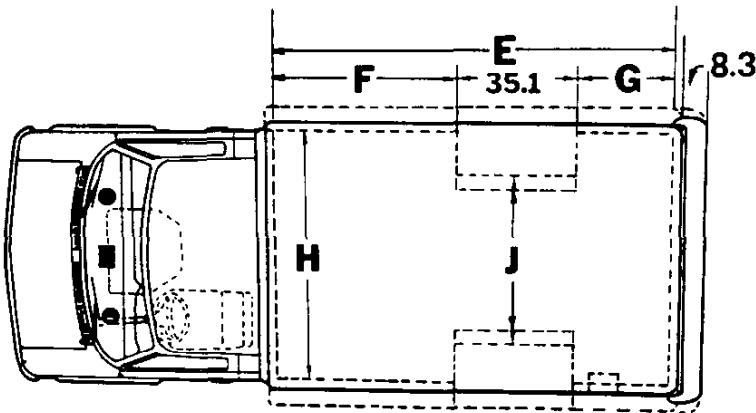
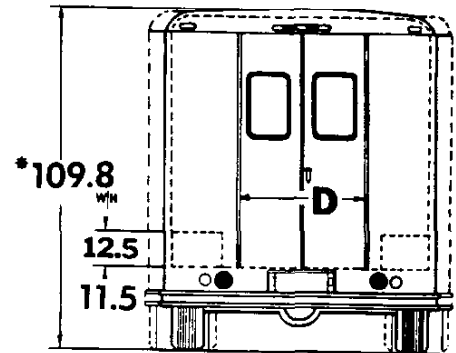
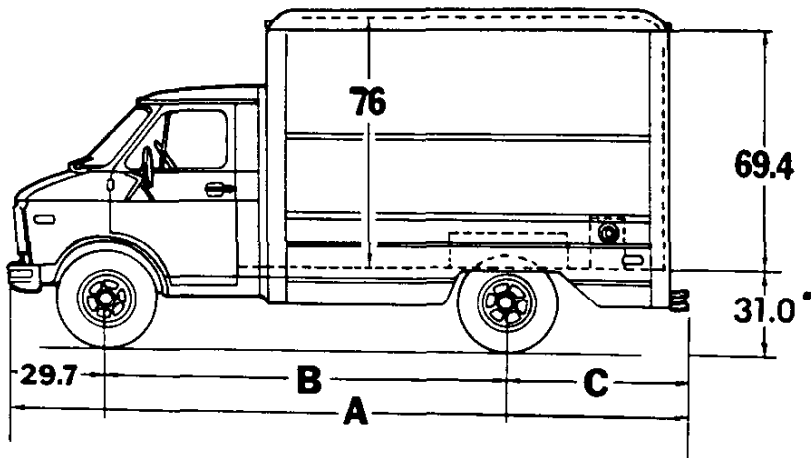

DIMENSIONS With Standard Equipment, Unloaded		LOAD SPACE LENGTH		
		Std. 10' (E31) (96" wide)	Std. 10' (E34) (82.5" wide)	Std. 12' (E38) (96" wide)
A	Overall Length (In)	211.6	211.6	235.6
B	Wheelbase (In)	125	125	146
C	Rear Overhang (In)	57	57	60
D	Standard Rear Door Width (In) Optional Rear Door Width (In)	38 60, 78.7	38 60, 66, 74.1	38 60, 78.7
E	Load Space Length (In)	120.7	120.7	144.7
F	Front of Wheelhousing (In)	56.4	56.4	77.4
G	Rear of Wheelhousing (In)	29.2	29.2	32.2
H	Load Space Width (In)	90.2	77.5	90.2
J	Width Between Wheelhousings (In)	50.3	52.6	50.3
K	Overall Width (In)	95.2	82.5	95.2
Cubic Capacity (Cu Ft)		469	406	564
Sign Panel Area (In x In)		54 x 118	54 x 118	54 x 142

\*This dimension varies depending on springs, tires and wheel size.

# HI-CUBE VAN/MAGNAVAN

## ALUMINUM BODIES DIMENSIONS

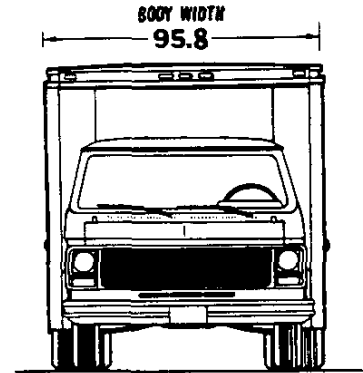
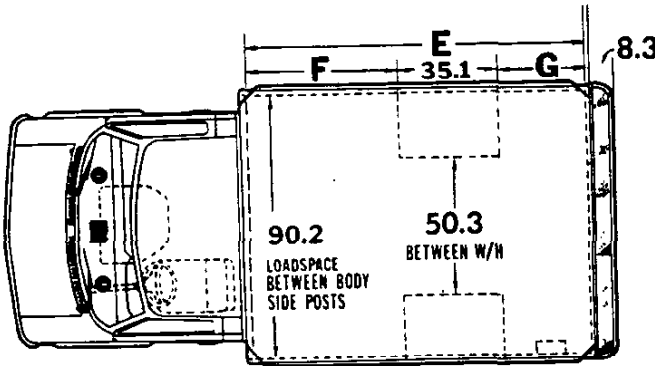
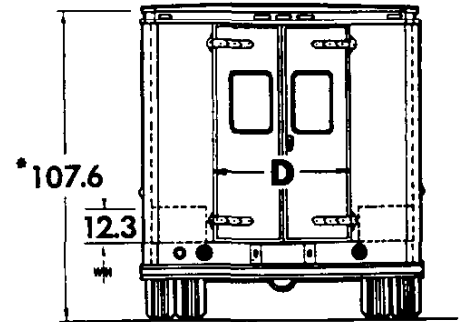
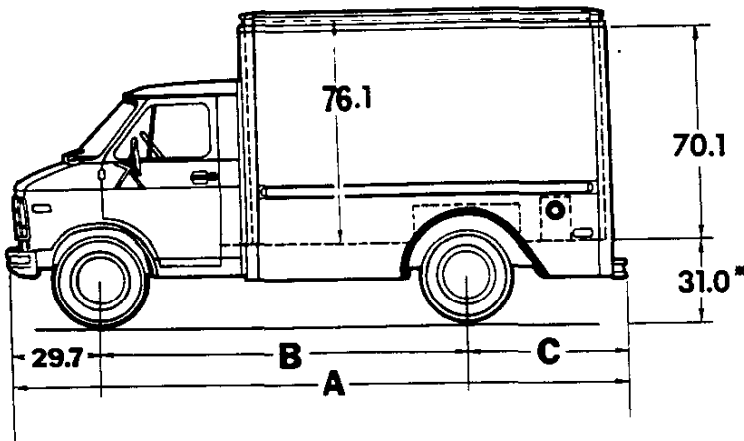

DIMENSIONS With Standard Equipment, Unloaded		LOAD SPACE LENGTH	
		Std. 10' (E36)	Std. 12' (E39)
A	Overall Length (In)	214.5	238.5
B	Wheelbase (In)	125	146
C	Rear Overhang (In)	59.9	62.9
D	Standard Rear Door Width (In) Optional Rear Door Widths (In)	38 60, 85.7	38 60, 85.7
E	Load Space Length (In)	120.8	144.8
F	Front of Wheelhousing (In)	54.9	75.9
G	Rear of Wheelhousing (In)	30.8	33.8
Cubic Capacity (Cu Ft)		475	570
Sign Panel Area (In x In)		54 x 118	54 x 142

\*This dimension varies depending on springs, tires and wheel size.



# CUTAWAY VAN & HI-CUBE VAN RALLY CAMPER SPECIAL, VANDURA SPECIAL & MAGNAVAN POWER TEAMS

## ALL STATES EXCEPT CALIFORNIA

NA5 Standard Emission Equipment Satisfies High Altitude Emission Requirements

### CUTAWAY VAN

**POWER TEAMS (MUST ORDER ENGINE, TRANSMISSION AND REAR AXLE)**  
(Consult GVWR Selector and Tire Chart to insure tire capacity and availability)

ENGINE	TRANSMISSION		AXLES				GVWR
	AUTO		#3.23	3.73	4.10	4.56	
<b>G31303 W/NA5 STANDARD OR NA6 HIGH ALTITUDE EMISSION EQUIPMENT</b>							
§LT9 V8 5.7 Liter (350-4 BBL)	MX1		#GQ1	GT4	—	—	7400
	MX1		—	—	GQ1	HC4	8600
	MX1		—	—	*GQ1	*HC4	8900
	MX1		—	—	*GT8	*HF7	%10000
■LL4 Diesel 6.2 Liter V8 (379 Cu. In.)(Reqs B3J)	MX1		#GQ1	GT4	—	—	7400
	MX1		—	—	GQ1	HC4	8600
	MX1		—	—	*GQ1	*HC4	8900
	MX1		—	—	*GT8	*HF7	%10000
<b>G31603 W/NA5 STANDARD, NA6 HIGH ALTITUDE</b>							
§LT9 V8 5.7 Liter (350-4BBL)	MX1		—	—	GQ1	HC4	8900
	MX1		—	—	GT8	HF7	10000
	MX1		—	—	GT8	GQ1	10500
■LL4 Diesel 6.2 Liter V8 (379 Cu. In.)(Reqs B3J)	MX1		—	—	GQ1	HC4	8900
	MX1		—	—	GT8	HF7	10000
	MX1		—	—	GT8	GQ1	10500

### HI-CUBE VAN

**POWER TEAMS (MUST ORDER ENGINE, TRANSMISSION AND REAR AXLE)**  
(Consult GVWR Selector and Tire Chart to insure tire capacity and availability)

ENGINE	TRANSMISSION		AXLES				GVWR
	AUTO		#3.23	3.73	4.10	4.56	
<b>G31303 W/NA5 STANDARD OR NA6 HIGH ALTITUDE EMISSION EQUIPMENT</b>							
§LT9 V8 5.7 Liter (350-4BBL)	MX1		#GQ1	GT4	—	—	7400
	MX1		—	—	GQ1	HC4	8600
	MX1		—	—	*GQ1	*HC4	8900
	MX1		—	—	—	—	7400
■LL4 Diesel 6.2 Liter V8 (379 Cu. In.)(Reqs B3J)	MX1		#GQ1	GT4	—	—	7400
	MX1		—	—	GQ1	HC4	8600
	MX1		—	—	*GQ1	*HC4	8900
	MX1		—	—	—	—	7400
<b>G31603 W/NA5 STANDARD, NA6 HIGH ALTITUDE</b>							
§LT9 V8 5.7 Liter (350-4BBL)	MX1		—	—	GQ1	HC4	8900
	MX1		—	—	GT8	HF7	10000
	MX1		—	—	GQ1	HC4	8900
■LL4 Diesel 6.2 Liter V8 (Reqs B3J) (379 Cu. In.)	MX1		—	—	GT8	HF7	10000
	MX1		—	—	—	—	7400
	MX1		—	—	GT8	HF7	10000

### RV CUTAWAY VAN

**POWER TEAMS (MUST ORDER ENGINE, TRANSMISSION AND REAR AXLE)**  
(Consult GVWR Selector and Tire Chart to insure tire capacity and availability)

ENGINE	TRANSMISSION		AXLES				GVWR
	AUTO		4.10	4.56			
<b>G31332 W/NA5 STANDARD OR NA6 HIGH ALTITUDE EMISSION EQUIPMENT</b>							
§LT9 V8 5.7 Liter (350-4BBL)	MX1				GQ1	HC4	8600
	MX1				*GQ1	*HC4	8900
	MX1				GQ1	HC4	8600
■LL4 Diesel 6.2 Liter V8 (379 Cu. In.)(Reqs B3J)	MX1				*GQ1	*HC4	8900
	MX1						
<b>G31632 W/NA5 STANDARD, NA6 HIGH ALTITUDE</b>							
§LT9 V8 5.7 Liter (350-4BBL)	MX1				GT8	GQ1	10500
	MX1				GT8	GQ1	10500

#N/A G50 Springs

\*N/A NA6 High Altitude Emissions. With NA5 Standard Emissions Satisfies High Altitude Requirements

%Reqs B3D School Bus Equipment

\*N/A G80 Locking Differential

■ High Altitude Emission Equipment (FOR EXHAUST SMOKE REDUCTION PURPOSES AT HIGH ALTITUDE; NOT REQUIRED TO SATISFY HIGH ALTITUDE EMISSION REGULATIONS).

# CUTAWAY VAN & HI-CUBE VAN RALLY CAMPER SPECIAL, VANDURA SPECIAL & MAGNAVAN POWER TEAMS

## CALIFORNIA ONLY

### CUTAWAY VAN

#### POWER TEAMS (MUST ORDER ENGINE, TRANSMISSION AND REAR AXLE)

(Consult GVWR Selector and Tire Chart to insure tire capacity and availability)

ENGINE	TRANSMISSION	AXLES				GVWR	
		AUTO	#3.23	3.73	4.10		4.56
<b>G31303 W/YF5 CALIFORNIA EMISSION REQUIREMENTS</b>							
*LT9 V8 5.7 Liter (350-488L)	MX1		—	—	GQ1	HC4	8600
	MX1		—	—	*GQ1	*HC4	8900
	MX1		—	—	*GT8	*HF7	%10000
LL4 Diesel 6.2 Liter V8 (379 Cu. In.)(Reqs B3J)	MX1		—	—	GQ1	HC4	8600
	MX1		—	—	*GQ1	*HC4	8900
	MX1		—	—	*GT8	*HF7	%10000
<b>G31603 W/YF5 CALIFORNIA EMISSIONS</b>							
*LT9 V8 5.7 Liter (350-488L)	MX1		—	—	GQ1	HC4	8900
	MX1		—	—	GT8	HF7	10000
	MX1		—	—	GT8	GQ1	10500
LL4 Diesel 6.2 Liter V8 (379 Cu. In.)(Reqs B3J)	MX1		—	—	GQ1	HC4	8900
	MX1		—	—	GT8	HF7	10000
	MX1		—	—	GT8	GQ1	10500

### HI-CUBE VAN

#### POWER TEAMS (MUST ORDER ENGINE, TRANSMISSION AND REAR AXLE)

(Consult GVWR Selector and Tire Chart to insure tire capacity and availability)

ENGINE	TRANSMISSION	AXLES				GVWR	
		AUTO	#3.23	3.73	4.10		4.56
<b>G31303 W/YF5 CALIFORNIA EMISSION REQUIREMENTS</b>							
*LT9 V8 5.7 Liter (350-488L)	MX1		—	—	GQ1	HC4	8600
	MX1		—	—	*GQ1	*HC4	8900
LL4 Diesel 6.2 Liter V8 (379 Cu. In.)(Reqs B3J)	MX1		—	—	GQ1	HC4	8600
	MX1		—	—	*GQ1	*HC4	8900
<b>G31603 W/YF5 CALIFORNIA EMISSIONS</b>							
*LT9 V8 5.7 Liter (350-488L)	MX1		—	—	GQ1	HC4	8900
	MX1		—	—	GT8	HF7	10000
LL4 Diesel 6.2 Liter V8 (Reqs B3J) (379 Cu. In.)	MX1		—	—	GQ1	HC4	8900
	MX1		—	—	GT8	HF7	10000

### RV CUTAWAY VAN

#### POWER TEAMS (MUST ORDER ENGINE, TRANSMISSION AND REAR AXLE)

(Consult GVWR Selector and Tire Chart to insure tire capacity and availability)

ENGINE	TRANSMISSION	AXLES		GVWR	
		AUTO	4.10		4.56
<b>G31332 W/YF5 CALIFORNIA EMISSION REQUIREMENTS</b>					
*LT9 V8 5.7 Liter (350-488L)	MX1		GQ1	HC4	8600
	MX1		*GQ1	*HC4	8900
	MX1		GQ1	HC4	8600
LL4 Diesel 6.2 Liter V8 (379 Cu. In.)(Reqs B3J)	MX1		*GQ1	*HC4	8900
	MX1				
<b>G31632 W/YF5 CALIFORNIA EMISSIONS</b>					
*LT9 V8 5.7 Liter (350-488L)	MX1		GT8	GQ1	10500
LL4 Diesel 6.2 Liter V8 (379 Cu. In.)(Reqs B3J)	MX1		GT8	GQ1	10500

#N/A G50 Springs  
 \$N/A NA6 High Altitude Emissions. With NA5 Standard Emissions Satisfies High Altitude Requirements  
 %Reqs B3D School Bus Equipment  
 \*N/A G80 Locking Differential

# CUTAWAY VAN & HI-CUBE VAN RALLY CAMPER SPECIAL, VANDURA SPECIAL & MAGNAVAN GVWR SELECTOR—ALL STATES

REFER TO FOREWORD—GENERAL INFORMATION SECTION, PAGE 13 FOR INCOMPLETE VEHICLE CURB WEIGHT AND FRONTAL AREA DATA.

GVW Rating (lbs)	+GAWR (lbs)		Minimum Equipment Required for GVW Rating			
			Tire Capacity (lbs ea)		Chassis Equipment	
	Front	Rear	Front	Rear		

### 125" WHEELBASE COMMERCIAL CUTAWAY VAN/VANDURA SPECIAL

■7400	3400	4200	2350	2350	Standard
■8600	3900	5360	2680	2680	Chassis Group (ZW1)
■8900	3400	6000	1730	1520 (Duals)	Chassis Group (ZW1), Dual Rear Wheel Provisions (R05)
10,000	3900	7200	2045	1800 (Duals)	7500-lb. Rear Axle (GT8 or HF7); School Bus Chassis Equipment (B3D); Dual Rear Wheel Provisions (R05)

### 146" WHEELBASE COMMERCIAL CUTAWAY VAN/VANDURA SPECIAL

■8900	3460	6080	1730	1520 (Duals)	Standard
10,000	3900	7200	2045	1800 (Duals)	7500-lb. Rear Axle (GT8 or HF7)
▲10,500	3900	7200	2045	1800 (Duals)	Standard on G31603/C7C

### ●125" WHEELBASE RV CUTAWAY VAN/RALLY CAMPER SPECIAL

■8600	3900	5360	2680	2680	Standard
■8900	3460	6000	1730	1520 (Duals)	Dual Rear Wheel Provisions (R05)

### ●146" WHEELBASE RV CUTAWAY VAN/RALLY CAMPER SPECIAL

10,500	3900	7200	2045	1800 (Duals)	Standard
--------	------	------	------	--------------	----------

### 125" WHEELBASE HI-CUBE VAN/MAGNAVAN

■7400	3400	4200	2350	2350	Standard
■8600	3900	5360	2680	2680	Chassis Group (ZW1), Steel (E34) Body
■8900	3400	6000	1730	1520 (Duals)	Not available on Steel (E34) body; Standard on Steel E31 and Aluminum E36 bodies.

### 146" WHEELBASE HI-CUBE VAN/MAGNAVAN

■8900	3460	6080	1730	1520 (Duals)	Standard
10,000	3900	7200	2045	1800 (Duals)	7500-lb. Rear Axle (GT8 or HF7)

\*GAWR's shown are the maximum for each axle with equipment listed. Other GAWR's are available, and they are determined as the minimum capacity of either axle, springs or tires.

■Not available in California.

●RV Cutaway Van/Rally Camper Special models, G31332 and G31632, are for recreational vehicle use only and are not to be used for the mounting of any type commercial body.

▲Standard and available only on model G31603/C7C.

## FRONT AND REAR TIRE AVAILABILITY CHART—ALL STATES

Spare tire to match either front or rear tires available at extra cost

	Capacity (lbs each)		Highway			On-Off Road	Spare
	Front/Single Rear	Dual Rear	Front	Single Rear	Dual Rear	Single Rear	
<b>TUBELESS</b>							
*8.00-16.5/C Nylon	1730	1520	XSC	—	YSC	—	ZSC
*8.00-16.9/C Polyester	1730	1520	XQC	—	YQC	—	ZQC
†8.00-16.5/C Polyester	1730	1520	XRQ	—	YRQ	—	ZRQ
*8.00-16.9/D Nylon	2045	1800	XSD	—	YSD	—	ZSD
*8.00-16.5/D Polyester	2045	1800	XRS	—	YRS	—	ZRS
*8.75-16.5/D Nylon	2350	—	XTE	YTE	—	—	ZTE
			—	—	—	YTF	ZTF
			—	—	—	—	ZTE
†8.75-16.5/E Nylon	2680	—	XTH	YTH	—	—	ZTH
†8.75R-16.5/E Steel Belted Radial	2680	—	XVD	YVD	—	—	ZVD

\*Not available RV Cutaway Van/Rally Camper Special.

†Available on 125" WB RV Cutaway Van/Rally Camper Special only.

■Requires 7500-lb. rear axle (GT8 or HF7) on Commercial Cutaway Vans/Vandura Special or 146" wheelbase Hi-Cube Van/Magnavan or RV Cutaway Van/Rally Camper Special.

†Available on 125" WB models only.

# CUTAWAY VAN & HI-CUBE VAN RALLY CAMPER SPECIAL, VANDURA SPECIAL & MAGNAVAN

## ENGINE RATINGS—ALL MODELS

### ALL STATES EXCEPT CALIFORNIA

SAE NET Ratings	5.7 Liter 350 4-bbl V8	6.2 Liter 379 V8 Diesel
Net Horsepower .....	160 @ 3800	135 @ 3600 rpm
Net Torque, lb-ft .....	250 @ 2800	240 @ 2000 rpm

### CALIFORNIA ONLY

SAE NET Ratings	5.7 Liter 350 4-bbl V8	6.2 Liter 379 V8 Diesel
Net Horsepower .....	155 @ 4000	135 @ 3600 rpm
Net Torque, lb-ft .....	240 @ 2800	240 @ 2000 rpm

**CUTAWAY VAN & HI-CUBE VAN  
RALLY CAMPER SPECIAL, VANDURA SPECIAL & MAGNAVAN  
THE FOLLOWING EQUIPMENT IS STANDARD ON DIESEL ENGINE MODELS  
(ALSO SEE STANDARD SPECIFICATIONS PAGES)**

- Low Coolant Sensor
- Poly-wrapped Paper Element Air Cleaner
- Auxiliary Engine Oil Cooler provided for 03/32 models with air conditioning and 4.56 ratio rear axle (in addition to cooler in radiator tank)
- Power Steering
- Engine Block Heater
- Water/fuel separator unit which incorporates a water sensor and sending unit, a fuel filter, a fuel heater and water drain capability
- Hydraulic Power-assisted Brakes
- K81 66-amp Generator
- Engine Oil Cooler (located in radiator tank)
- Dual 550 Cold Cranking Amp/115 min. Reserve Capacity Batteries
- HD Radiator
- Dual Exhaust System
- Warning Lights: Glow Plugs, Water-in-fuel (or fuel filter), and Low Coolant
- Diesel Engine Identification:
  - Fender nameplates
  - LH rear door nameplate (Hi-Cube models only)
  - “Diesel Fuel Only” filler cap and label

# CUTAWAY/VANDURA SPECIAL/RALLY CAMPER SPECIAL/MAGNAVAN AND HI-CUBE VAN (7400-lb - 10,500-lb GVW)

## 1984 VEHICLES WITH STANDARD EQUIPMENT

Prices shown are effective with vehicles produced on and after February 13, 1984

Description	Model Number	Body Code	Wheel Base	Factory D&H(a)	List Price	Mfr's Suggested Retail Price*	Group Number
<b>◆ 8-Cylinder 5.7 Liter (350 Cu. In.) 4 BBL V8 Gasoline Engine-Engine Ordering Code LT9</b>							
≠ Commercial Cutaway Van	CG/TG31303	ZW9	125"	N.A.	8655.00	8655.00	14
** Hi-Cube Van Steel (10-Ft) 82" Wide	CG/TG31303	E34	125"	N.A.	11725.00	11725.00	15
Commercial Cutaway Van	CG/TG31603	ZW9	146"	N.A.	9685.00	9685.00	14
H.D. Commercial Cutaway Van	CG/TG31603	ZW9 & C7C	146"	N.A.	10417.00	10417.00	14
RV Cutaway Van	CG/TG31332	ZW9	125"	.16	9157.00	9157.16	14
RV Cutaway Van	CG/TG31632	ZW9	146"	N.A.	10097.00	10097.00	14
** Hi-Cube Van Steel (10-Ft) 96" Wide	CG/TG31303	E31	125"	N.A.	12746.00	12746.00	15
Aluminum (10-Ft)	CG/TG31303	E36	125"	N.A.	14060.00	14060.00	15
Steel (12-Ft)	CG/TG31603	E38	146"	N.A.	13004.00	13004.00	15
Aluminum (12-Ft)	CG/TG31603	E39	146"	N.A.	14430.00	14430.00	15
<b>◆ 8-Cylinder 6.2 Liter (379 Cu. In.) H.D. Diesel V8 Engine-Engine Ordering Code LL4</b>							
≠ Commercial Cutaway Van	CG/TG31303	ZW9 & B3J	125"	N.A.	10873.00	10873.00	14
** Hi-Cube Van Steel (10-Ft) 82" Wide	CG/TG31303	E34 & B3J	125"	N.A.	13913.00	13913.00	15
Commercial Cutaway Van	CG/TG31603	ZW9 & B3J	146"	N.A.	11696.00	11696.00	14
H.D. Commercial Cutaway Van	CG/TG31603	ZW9 & C7C & B3J	146"	N.A.	12421.00	12421.00	14
RV Cutaway Van	CG/TG31332	ZW9 & B3J	125"	.16	11267.00	11267.16	14
RV Cutaway Van	CG/TG31632	ZW9 & B3J	146"	N.A.	12104.00	12104.00	14
** Hi-Cube Van Steel (10-Ft) 96" Wide	CG/TG31303	E31 & B3J	125"	N.A.	14727.00	14727.00	15
Aluminum (10-Ft)	CG/TG31303	E36 & B3J	125"	N.A.	16028.00	16028.00	15
Steel (12-Ft)	CG/TG31603	E38 & B3J	146"	N.A.	14982.00	14982.00	15
Aluminum (12-Ft)	CG/TG31603	E39 & B3J	146"	N.A.	16394.00	16394.00	15

\* Manufacturer's Suggested Retail Prices do not include applicable destination charges, state and local taxes, license fees, optional equipment or accessories or special items or services.

◆ Refer to Dealer Order Guide for California Requirements.

\*\* Van models will be shipped to Union City Body Co. where all body work will be done. These units will be serviced and conditioned for highway travel after body is installed.

≠ Factory D&H is not applicable and will not be reflected in the MSRP when B3D School Bus Chassis is specified.

Please Note: Anyone ordering a vehicle for completion or modification and use as a bus and/or school bus is solely responsible for assuring that such completed vehicle and associated equipment, which might be ordered for the vehicle, comply with all applicable Local, State, and Federal Government requirements.

(a) D & H Charges on vehicle and optional equipment include reimbursement to ordering Division for any tax that it has paid, incurred or agreed to pay thereon.  
◇ State and local taxes not included.

# CUTAWAY/VANDURA SPECIAL/RALLY CAMPER SPECIAL/MAGNAVAN AND HI-CUBE VAN

## OPTIONS AND ACCESSORIES WHEN INSTALLED BY GENERAL MOTORS

Prices shown are effective with vehicles produced on and after February 13, 1984

Description	Option Number	Factory D&H(a)	List Price	Mfr's Suggested Retail Price◇
<b>Seat Trim:</b> Driver and Passenger. (See Interior and Exterior Color Selection Chart for Ordering Information).				
<i>V**2 Standard Vinyl Bucket Seats</i> .....				
<i>V**4 Vinyl High Back Bucket Seats</i> .....				
Without A57 Auxiliary Seat .....				
With A57 Auxiliary Seat .....				
<i>X**4 Custom Vinyl High Back Bucket Seats.</i>				
Without Z73 Special Interior Trim.				
Without A57 Auxiliary Seat .....				
With A57 Auxiliary Seat .....				
With Z73 Special Interior Trim .....				
<i>K**4 Custom Cloth High Back Bucket Seats.</i> Available only when Z73 Special Interior Trim is specified .....				
<b>Trim, Special Exterior:</b> Includes V22 Deluxe Front Appearance, windshield moldings, headlight and front side marker lamp accents				
Without B3J Diesel Equipment .....				
With B3J Diesel Equipment .....				
<b>Trim, Special Interior:</b> (See Interior and Exterior Color Selection Chart for availability and ordering information) Includes A57 Front Auxiliary Seat, stepwell mats, two-way manual adjuster, RH armrest, seat belt, D20 Passenger Sunshade, front door trim panels, bright accents on instrument panel, dual horns, additional front wheelhouse and instrument panel insulation. (Added weight includes passenger weight allowance of 150-lbs per seating position on passenger seat only)				
Without RV Cutaway Van. Also includes U37 Cigarette Lighter .....				
With RV Cutaway Van .....				
G31332 .....				
G31632 .....				
<b>Paints, Exterior:</b> (See Interior and Exterior Color Selection Chart for Ordering Information and Paint Application). Solid.				
Cutaway Van or Steel Hi-Cube Van only .....				
Aluminum Hi-Cube Van only .....				
Two-Tone. Aluminum Hi-Cube Van only .....				
<b>Emission Systems:</b> Dealer Note - One of the following emission options must be specified. (See Power Teams Chart for availability and complete specifications)				
<i>California Emission Requirements.</i> Includes all testing, equipment and/or certification necessary for registration in the State of California.				
Without B3J Diesel Equipment .....				
With B3J Diesel Equipment .....				
<b>High Altitude Emission Equipment.</b> Available only when B3J Diesel Equipment is specified. Not available when YF5 California Emissions are specified. ....				
<b>Standard Emission Equipment.</b> Not available when NA6 High Altitude or YF5 California Emissions are specified .....				
<b>Engines:</b> (See Power Teams Chart for availability and complete specifications)				
Gasoline.				
5.7 Liter (350 Cu. In.) 4 BBL V8 .....				
Diesel				
6.2 Liter (379 Cu. In.) H.D. V8 Diesel. Available only when B3J Diesel Equipment is specified .....				
<b>Transmission:</b> 3-Speed Automatic. ....				

(a) D & H Charges on vehicle and optional equipment include reimbursement to ordering Division for any tax that it has paid, incurred or agreed to pay thereon.  
◇ State and local taxes not included.

# CUTAWAY/VANDURA SPECIAL/RALLY CAMPER SPECIAL/MAGNAVAN AND HI-CUBE VAN

## OPTIONS AND ACCESSORIES WHEN INSTALLED BY GENERAL MOTORS

Prices shown are effective with vehicles produced on and after February 13, 1984

Description	Option-Number	Factory D&H(a)	List Price	Mfr's Suggested Retail Price◇
<b>Axles, Rear:</b> (See Power Teams Chart for option number selection, availability and complete specifications)				
Optional Ratio .....		N.A.	36.00	36.00
<b>Capacity 7500-lb.</b>				
G31603 or G31632 only				
4.10 Ratio. Commercial Cutaway Van, Steel or Aluminum Hi-Cube Van available only when SD or RS 8.00-16.5/D Tires are specified.				
With Commercial Cutaway Van, Steel or Aluminum Hi-Cube Van .....	GT8	N.A.	123.00	123.00
With RV Cutaway Van or H.D. Commercial Cutaway Van/Vandura Special .....	GT8	N.A.	36.00	36.00
4.56 Ratio. Standard on RV Cutaway Van or H.D. Commercial Cutaway Van/Vandura Special, Commercial Cutaway Van, Steel or Aluminum Hi-Cube Van available only when SD or RS 8.00-16.5/D Tires are specified.				
G31603 .....	HF7	N.A.	159.00	159.00
G31303 Commercial Cutaway Van only. Available only when B3D School Bus Chassis Equipment is specified. Includes heavy-duty front springs.				
4.10 Ratio .....	GT8	N.A.	190.00	190.00
4.56 Ratio .....	HF7	N.A.	190.00	190.00
<b>Locking Differential.</b> G31303 or G31332 only. Not available when R05 Dual Rear Wheels, E31 or E36 Body is specified				
	G80	N.A.	230.00	230.00
<b>Tires:</b> (See Tire Charts for Tire Availability)				
All rim sizes are 6.75" without R05 Dual Rear Wheels				
All rim sizes are 6.00" with R05 Dual Rear Wheels				
<b>Dealer Note:</b> When dual rear tires are specified R05 Dual Rear Wheels will be applied to the order. THIS EQUIPMENT IS NOT PRICED IN THE TIRE OPTION AND WILL BE REFLECTED ON THE INVOICE SEPARATELY.				
For complete specifications and ordering information, see "OTHER OPTIONS" Section.				
<b>TUBELESS</b>				
<b>8.75-16.5/D Highway Nylon Blackwall</b>				
(Maximum Capacity Front and Single Rear 2350-lbs)				
G31303 Cutaway Van or E34 Steel Hi-Cube Van only.				
Front (Standard) .....	XTE			NO ADDITIONAL CHARGE
Rear (Standard) .....	YTE			NO ADDITIONAL CHARGE
Spare. Available on Hi-Cube Van only when P14 or P15 Spare Wheel Carrier is specified. ....	ZTE	N.C.	194.00	194.00
<b>8.75-16.5/D On-Off Road Nylon Blackwall</b>				
(Maximum Capacity 2350-lbs)				
G31303 Cutaway Van or E34 Steel Hi-Cube Van only.				
Rear .....	YTF	12	48.00	48.12
Spare. Available on Hi-Cube Van only when P14 or P15 Spare Wheel Carrier is specified. ....	ZTF	.06	218.00	218.06
<b>8.75-16.5/E Highway Nylon Blackwall</b>				
(Maximum Capacity Front and Single Rear 2680-lbs)				
G31303 Cutaway Van, E34 Steel Hi-Cube Van or G31332 RV Cutaway Van only.				
Front				
G31303 Cutaway Van or E34 Steel Hi-Cube Van ....	XTH	.08	34.00	34.08
G31332 RV Cutaway Van (Standard) .....	XTH			NO ADDITIONAL CHARGE
Rear				
G31303 Cutaway Van or E34 Steel Hi-Cube Van ....	YTH	.08	34.00	34.08
G31332 RV Cutaway Van (Standard) .....	YTH			NO ADDITIONAL CHARGE
Spare. Available on Hi-Cube Van only when P14 or P15 Spare Wheel Carrier is specified. ....	ZTH	.04	211.00	211.04
<b>8.75R-16.5/E Highway Steel Belted Blackwall</b>				
(Maximum Capacity Front and Single Rear 2680-lbs)				
G31332 RV Cutaway Van Only				
Front .....	XVD	1.50	144.00	145.50
Rear .....	YVD	1.50	144.00	145.50
Spare. ....	ZVD	.79	283.00	283.79

(a) D & H Charges on vehicle and optional equipment include reimbursement to ordering Division for any tax that it has paid, incurred or agreed to pay thereon.  
◇ State and local taxes not included.



# CUTAWAY/VANDURA SPECIAL/RALLY CAMPER SPECIAL/MAGNAVAN AND HI-CUBE VAN

## OPTIONS AND ACCESSORIES WHEN INSTALLED BY GENERAL MOTORS

Prices shown are effective with vehicles produced on and after February 13, 1984

Description	Option Number	Factory D&H(a)	List Price	Mfr's Suggested Retail Price◇
<b>Tires: (Continued)</b>				
<i>8.00-16.5/C Highway Nylon Blackwall</i>				
(Maximum Capacity, Front 1730-lbs) (Dual Rear 1520-lbs)				
Not available on E34 82" Wide Hi-Cube Van or RV Cutaway Van.				
Front.				
Without E31 Steel Body or E36 Aluminum Body				
Without B3D School Bus Chassis Equipment	XSC	N.C.	(-36.00)	(-36.00)
With B3D School Bus Chassis Equipment	XSC	N.C.	(-36.00)	(-36.00)
With E31 Steel Body, E36 Aluminum Body, G31603 Commercial Cutaway Van or Hi-Cube Van (Standard)				
	XSC	NO ADDITIONAL CHARGE		
Rear.				
G31303 or G31603 only				
Without E31 Steel Body or E36 Aluminum Body				
Without B3D School Bus Chassis Equipment	YSC	N.C.	316.00	316.00
With B3D School Bus Chassis Equipment	YSC	N.C.	316.00	316.00
With E31 Steel Body, E36 Aluminum Body, G31603 Commercial Cutaway Van or Hi-Cube Van (Standard)				
	YSC	NO ADDITIONAL CHARGE		
Spare				
G31303 Commercial Cutaway Van or G31303 Hi-Cube Van only. Available on Hi-Cube Van only when P14 or P15 Spare Wheel Carrier is specified.				
Without B3D School Bus Chassis Equipment	ZSC	N.C.	176.00	176.00
With B3D School Bus Chassis Equipment	ZSC	N.C.	176.00	176.00
G31603 Commercial Cutaway Van or Hi-Cube Van. Available on Hi-Cube Van only when P14 or P15 Spare Wheel Carrier is specified.				
	ZSC	N.C.	176.00	176.00
<i>8.00-16.5/C Highway Polyester Blackwall</i>				
(Maximum Capacity, Front 1730-lbs) (Dual Rear 1520-lbs)				
Not available on E34 Hi-Cube Van or RV Cutaway Van.				
Front				
Without E31 Steel Body or E36 Aluminum Body				
Without B3D School Bus Chassis Equipment	XQC	N.C.	(-16.00)	(-16.00)
With B3D School Bus Chassis Equipment	XQC	N.C.	(-16.00)	(-16.00)
G31303 E36 Aluminum or E31 Steel Hi-Cube Van only				
	XQC	N.C.	20.00	20.00
G31603 Commercial Cutaway Van or Hi-Cube Van				
	XQC	N.C.	20.00	20.00
Rear				
G31303 or G31603 only				
Without E31 Steel Body or E36 Aluminum Body				
Without B3D School Bus Chassis Equipment	YQC	N.C.	356.00	356.00
With B3D School Bus Chassis Equipment	YQC	N.C.	356.00	356.00
With E31 Steel Body or E36 Aluminum Body, G31603 Commercial Cutaway Van or Hi-Cube Van				
	YQC	N.C.	40.00	40.00
Spare				
G31303 Commercial Cutaway Van or G31303 Hi-Cube Van only. Available on Hi-Cube Van only when P14 or P15 Spare Wheel Carrier is specified.				
Without B3D School Bus Chassis Equipment	ZQC	N.C.	186.00	186.00
With B3D School Bus Chassis Equipment	ZQC	N.C.	186.00	186.00
G31603 Commercial Cutaway Van or Hi-Cube Van. Available on Hi-Cube Van only when P14 or P15 Spare Wheel Carrier is specified.				
	ZQC	N.C.	186.00	186.00
<i>8.00-16.5/C Highway Polyester Blackwall</i>				
(Maximum Capacity, Front 1730-lbs) (Dual Rear 1520-lbs)				
G31332 RV Cutaway Van only.				
Front	XRQ	(-.08)	(-50.00)	(-50.08)
Rear	YRQ	(-.08)	322.00	321.92
Spare	ZRQ	N.C.	186.00	186.00

(a) D & H Charges on vehicle and optional equipment include reimbursement to ordering Division for any tax that it has paid, incurred or agreed to pay thereon.  
◇ State and local taxes not included.

# CUTAWAY/VANDURA SPECIAL/RALLY CAMPER SPECIAL/MAGNAVAN AND HI-CUBE VAN

## OPTIONS AND ACCESSORIES WHEN INSTALLED BY GENERAL MOTORS

Prices shown are effective with vehicles produced on and after February 13, 1984

Description	Option Number	Factory D&H(a)	List Price	Mfr's Suggested Retail Price◇
<b>Tires: (Continued)</b>				
<i>8.00-16.5 /D Highway Nylon Blackwall</i>				
(Maximum Capacity, Front 2045-lbs) (Dual Rear 1800-lbs)				
Hi-Cube Van with 7500-lb. Rear Axle or G31603 Commercial Cutaway Van only.				
Front. Standard on G31603 H.D. Commercial Cutaway Van .....	XSD	N.C.	34.00	34.00
Rear. Standard on G31603 H.D. Commercial Cutaway Van .....	YSD	N.C.	68.00	68.00
Spare. Commercial Cutaway Van or Hi-Cube Van. Available on Hi-Cube Van only when P14 or P15 Spare Wheel Carrier is specified. ....	ZSD	N.C.	193.00	193.00
G31303 Commercial Cutaway Van only. Available only when B3D School Bus Chassis Equipment and GT8 or HF7 Axle are specified.				
Front .....	XSD	N.C.	(-2.00)	(-2.00)
Rear .....	YSD	N.C.	384.00	384.00
Spare .....	ZSD	N.C.	193.00	193.00
<i>8.00-16.5/D Highway Polyester Blackwall</i>				
(Maximum Capacity, Front 2045-lbs, Dual Rear 1800-lbs)				
G31603 or G31632 only				
Front				
G31603 Commercial Cutaway Van or Hi-Cube Van ..	XRS	N.C.	54.00	54.00
G31603 H.D. Commercial Cutaway Van .....	XRS	N.C.	20.00	20.00
G31632. (Standard) .....	XRS	<i>NO ADDITIONAL CHARGE</i>		
Rear				
G31603 Commercial Cutaway Van or Hi-Cube Van ..	YRS	N.C.	108.00	108.00
G31603 H.D. Commercial Cutaway Van .....	YRS	N.C.	40.00	40.00
G31632. (Standard) .....	YRS	<i>NO ADDITIONAL CHARGE</i>		
Spare. Available on Hi-Cube Van only when P14 or P15 Spare Wheel Carrier is specified. G31603 or RV Cutaway Van .....	ZRS	N.C.	203.00	203.00
G31303 Commercial Cutaway Van only. Available only when B3D School Bus Chassis Equipment and GT8 or HF7 Axle are specified.				
Front .....	XRS	N.C.	18.00	18.00
Rear .....	YRS	N.C.	424.00	424.00
Spare .....	ZRS	N.C.	203.00	203.00

### OTHER OPTIONS

**Air Conditioning: All-Weather.**

G31303 only.

Without ZW1 Chassis Group, B3J Diesel Equipment, E31 Steel or E36 Aluminum Hi-Cube Van. Includes K81 66-Amp Generator .....

C60

N.A.

845.00

845.00

With ZW1 Chassis Group, B3J Diesel Equipment, E31 Steel or E36 Aluminum Hi-Cube Van .....

C60

N.A.

785.00

785.00

G31332, G31603 or G31632 only .....

C60

N.A.

785.00

785.00

**Appearance, Deluxe Front:** Included when Z80 Special Exterior Trim is specified. Includes dark argent grille with bright trim.

Without B3J Diesel Equipment. Includes dual rectangular headlamps .....

V22

N.A.

114.00

114.00

With B3J Diesel Equipment. Also includes single rectangular headlamps .....

V22

N.A.

74.00

74.00

**Batteries: 12-Volt, 515 Cold Cranking Amps Delco Freedom.** Not available when B3J Diesel Equipment is specified.

**Auxiliary.** .....

TP2

N.A.

122.00

122.00

**Heavy-Duty.** Standard on E31 Steel, E36 Aluminum, G31603, G31632 or G31332. Included when ZW1 Chassis Group is specified .....

UA1

N.A.

50.00

50.00

(a) D & H Charges on vehicle and optional equipment include reimbursement to ordering Division for any tax that it has paid, incurred or agreed to pay thereon.

◇ State and local taxes not included.

# CUTAWAY/VANDURA SPECIAL/RALLY CAMPER SPECIAL/MAGNAVAN AND HI-CUBE VAN

## OPTIONS AND ACCESSORIES WHEN INSTALLED BY GENERAL MOTORS

Prices shown are effective with vehicles produced on and after February 13, 1984

Description	Option Number	Factory D&H(a)	List Price	Mfr's Suggested Retail Price◇
<b>OTHER OPTIONS</b>				
<b>Brake Warning Indicator:</b> Available only when B3D School Bus Equipment is specified	UJ1	N.A.	40.00	40.00
<b>Bumper Equipment:</b>				
<i>Bumper, Front.</i> Chromed. Standard on G31632 RV Cutaway Van	V46	N.A.	35.00	35.00
<i>Guards, Front.</i> Available only when V46 Front Bumper or G31632 RV Cutaway Van is specified	V31	N.A.	40.00	40.00
<b>Chassis Group, Heavy-Duty:</b> G31303 only. Included when E31 or E36 Body is specified on Hi-Cube Van.				
With ZW9 Commercial Cutaway Van or E34 Steel Hi-Cube Van.				
Without B3J Diesel Equipment.				
Without R05 Dual Rear Wheels. Available only when TH Tires are specified. Includes F60 H.D. Front Springs, G50 H.D. Rear Springs, F59 Stabilizer Bar, UA1 H.D. Battery and K81 66-Amp Generator	ZW1	N.A.	214.00	214.00
With R05 Dual Rear Wheels. Includes K81 66-Amp Generator and UA1 H.D. Battery	ZW1	N.A.	110.00	110.00
With B3J Diesel Equipment. Available only when TH Tires or R05 Dual Rear Wheels are specified.				
Without R05 Dual Rear Wheels. Includes F60 H.D. Front Springs, G50 H.D. Rear Springs and F59 Stabilizer Bar	ZW1	N.A.	104.00	104.00
With R05 Dual Rear Wheels. Includes F59 Stabilizer Bar	ZW1	NO ADDITIONAL CHARGE		
With E31 Steel or E36 Aluminum Hi-Cube Van	ZW1	NO ADDITIONAL CHARGE		
<b>Clock:</b> Quartz Electric	U35	N.A.	38.00	38.00
<b>Coolers:</b> Not available when B3J Diesel Equipment is specified.				
<i>Engine Oil.</i> Available only when V02 Transmission Oil Cooler is specified.	KC4	N.A.	116.00	116.00
<i>Transmission Oil, Heavy-Duty</i>	V02	N.A.	57.00	57.00
<b>Cooling System:</b> Heavy-Duty. Not available when C60 Air Conditioning or B3J Diesel Equipment is specified. Includes increased cooling capacity radiator and clutch type fan				
	V05	N.A.	51.00	51.00
<b>Floor Covering:</b> Mats Color-Keyed Front Floor. Available only when Z73 Special Interior Trim is specified				
	B32	N.A.	20.00	20.00
<b>Gages:</b> Voltmeter, Temperature and Oil Pressure. Standard on G31632 RV Cutaway Van				
	Z53	N.A.	38.00	38.00
<b>Generator:</b> 66-Amp Delcotron. G31303 only. Standard on G31603 or RV Cutaway Van. Included when ZW1 Chassis Group, E31 Steel or E36 Aluminum Body, B3J Diesel Equipment or C60 Air Conditioning is specified.				
	K81	N.A.	60.00	60.00
<b>Glass:</b> Tinted.				
<i>All Windows.</i> Includes A02 Windshield Glass	A01	N.A.	44.00	44.00
<i>Windshield only.</i> Included when A01 Glass is specified	A02	N.A.	35.00	35.00
<b>Headlamps:</b>				
<i>Halogen.</i> Not available with V22 Deluxe Front Appearance or Z80 Special Exterior Trim unless B3J Diesel Equipment is specified	TT4	N.A.	21.00	21.00
<i>Halogen Hi-Beam.</i> Available only when V22 Deluxe Front Appearance or Z80 Special Exterior Trim is specified. Not available when B3J Diesel Equipment is specified	TT5	N.A.	16.00	16.00
<b>Heater, Engine Block:</b> 600 watts, 120 volts. Not available when B3J Diesel Equipment is specified				
	K05	N.A.	31.00	31.00
<b>Lamps:</b> Rear Side Marker. Standard on Hi-Cube Van. Shipped loose for Body Company installation				
	U84	N.A.	11.00	11.00
<b>Lighter, Cigarette:</b> Standard on RV Cutaway Van. Included when Z73 Special Interior Trim is specified				
	U37	N.A.	29.00	29.00

(a) D & H Charges on vehicle and optional equipment include reimbursement to ordering Division for any tax that it has paid, incurred or agreed to pay thereon.  
◇ State and local taxes not included.

**CUTAWAY/VANDURA SPECIAL/RALLY CAMPER  
SPECIAL/MAGNAVAN AND HI-CUBE VAN  
OPTIONS AND ACCESSORIES WHEN INSTALLED BY GENERAL MOTORS**

Prices shown are effective with vehicles produced on and after February 13, 1984

Description	Option Number	Factory D&H(a)	List Price	Mfr's Suggested Retail Price◇
<b>OTHER OPTIONS</b>				
<b>Mirrors, Exterior:</b> LH and RH.				
<i>Below-Eye-Line Type.</i> 9" x 6.5". Painted. Commercial Cutaway Van only. Included when E34 Steel Hi-Cube Van is specified	D44	N.A.	63.00	63.00
<i>Camper Type.</i> 7.5" x 10.5".				
Painted. Standard on E36 or E39 Aluminum Hi-Cube Van, E31 Steel Hi-Cube Van or E38 Steel Hi-Cube Van. Not available on G31303 82" Wide E34 Steel Hi-Cube Van	DF1	N.A.	85.00	85.00
Stainless Steel. Not available when E34 Steel Hi-Cube Van is specified.				
Commercial Cutaway Van or RV Cutaway Van only . . . .	DF2	N.A.	98.00	98.00
E31 or E38 Steel Hi-Cube Van, E36 or E39 Aluminum Hi-Cube Van . . . . .	DF2	N.A.	13.00	13.00
<b>Preliminary Price Information</b> . . . . .	B3W	N.A.	N.A.	N.A.
<b>Radio Equipment:</b>				
<i>AM Radio.</i> Includes dual front speakers . . . . .	U63	N.A.	112.00	112.00
<i>AM/FM Radio</i> . . . . .	U69	N.A.	171.00	171.00
<i>AM/FM Stereo Radio</i> . . . . .	U58	N.A.	178.00	178.00
<i>AM/FM Stereo Radio with Stereo Cassette Tape</i> . . . . .	UN3	N.A.	278.00	278.00
<b>School Bus Chassis Equipment:</b> G31303 Cutaway Van only. Available only when F51 Shock Absorbers and R05 Dual Rear Wheels are specified. Includes 1950-lb each H.D. Front Springs. Also includes 3000-lb each H.D. rear springs unless HF7 or GT8 Rear Axle is specified. . . . .				
	B3D	N.A.	20.00	20.00
<b>Seat:</b> <i>Front Auxiliary.</i> Stationary Type. Included when Z73 Special Interior Trim is specified. Includes RH armrest, seat adjuster, seat belt and D20 Passenger Sunshade. (Added weight includes passenger weight allowance of 150-lbs per seating position. Refer to vehicle and option weight section of Data Book.) . . . . .				
	A57	N.A.	168.00	168.00
<b>Shock Absorbers:</b> <i>Front and Rear, Heavy-Duty.</i> G31303 or G31332 only . . . . .				
	F51	N.A.	32.00	32.00
<b>Speed Control, Electronic</b> . . . . .				
	K34	N.A.	185.00	185.00
<b>Springs:</b> <i>Heavy-Duty.</i> G31303 only. Standard on G31603 and RV Cutaway Van. Not available when R05 Dual Rear Wheels or E31 or E36 Body is specified. Included when ZW1 Chassis Group is specified.				
<i>Front.</i> Capacity 1950-lb each . . . . .	F60	N.A.	14.00	14.00
<i>Rear.</i> Capacity 3000-lb each. Not available when B3D School Bus Chassis is specified . . . . .	G50	N.A.	55.00	55.00
<b>Stabilizer Bar:</b> <i>Front.</i> G31303 only. Standard on G31603, G31332 or G31632. Included when ZW1 Chassis Group is specified . . . . .				
	F59	N.A.	35.00	35.00
<b>Steering Wheels:</b>				
<i>Comfortilt</i> . . . . .	N33	N.A.	110.00	110.00
<i>Custom</i> . . . . .	N31	N.A.	25.00	25.00
<b>Sunshade, Passenger:</b> Included when A57 Auxiliary Seat or Z73 Special Interior Trim is specified . . . . .				
	D20	N.A.	18.00	18.00
<b>Tank, Fuel:</b> Approximately 33-gallon capacity. Replaces standard fuel tank. Standard on RV Cutaway Van . . . . .				
	NL7	N.A.	85.00	85.00
<b>Wheel Trim:</b> <i>Bright Metal Wheel Covers.</i> Available only when R05 Dual Rear Wheels, E31 Steel or E36 Aluminum Body is specified . . . . .				
	P01	N.A.	52.00	52.00

(a) D & H Charges on vehicle and optional equipment include reimbursement to ordering Division for any tax that it has paid, incurred or agreed to pay thereon.  
◇ State and local taxes not included.

# CUTAWAY/VANDURA SPECIAL/RALLY CAMPER SPECIAL/MAGNAVAN AND HI-CUBE VAN

## OPTIONS AND ACCESSORIES WHEN INSTALLED BY GENERAL MOTORS

Prices shown are effective with vehicles produced on and after February 13, 1984

Description	Option Number	Factory D&H(a)	List Price	Mfr's Suggested Retail Price ◊
<b>OTHER OPTIONS</b>				
<b>Wheels, Dual Rear:</b> Standard on E31 Steel Hi-Cube Van or G31303 E36 Aluminum Hi-Cube Van, G31603 or G31632 only. Not available on E34 Steel Hi-Cube Van. Includes hydraulic power assisted brake system, 3400-lb capacity front springs, 6000-lb capacity rear springs, dual rear chassis provisions and 6200-lb capacity rear axle as reflected on Power Teams Chart.				
G31303 ZW9 Commercial Cutaway Van. Available only when ZW1 Chassis Group is specified. Not available when TE, TF or TH Tires are specified .....	R05	N.A.	431.00	431.00
G31332 RV Cutaway Van. Not available when TH or VD Tires are specified .....	R05	N.A.	341.00	341.00
<b>Wheels, Single Rear:</b> G31303 Commercial Cutaway Van or G31332 RV Cutaway Van only. Not available when R05 Dual Rear Wheels are specified .....	R04	NO ADDITIONAL CHARGE		
<b>Wheels, Spare:</b> 16.5" x 6.00" Included when spare tire is specified.				
Commercial Cutaway and RV Cutaway. Available only when R05 Dual Rear Wheels are specified on G31303 or G31332 .....	QE6	N.A.	46.00	46.00
Hi-Cube Van. Available only when P14 or P15 Spare Wheel Carrier is specified .....	QE6	N.A.	46.00	46.00
<b>Windows: Power</b> .....	A31	N.A.	180.00	180.00
<b>Windshield Wiper System: Intermittent</b> .....	CD4	N.A.	50.00	50.00

(a) D & H Charges on vehicle and optional equipment include reimbursement to ordering Division for any tax that it has paid, incurred or agreed to pay thereon.  
 ◊ State and local taxes not included.

# HI-CUBE VAN/MAGNAVAN

## OPTIONS AND ACCESSORIES WHEN INSTALLED BY UNION CITY BODY COMPANY

Prices shown are effective with vehicles produced on and after February 13, 1984

Description	Option Number	Factory D&H(a)	List Price	Mfr's Suggested Retail Price◇
<b>Dealer Note:</b> When ordering E31, E34, E36, E38 or E39 Body, one of the following options must be specified.				
Regular Body Options only .....	YJ1		NO ADDITIONAL CHARGE	
Special Body Options required .....	YJ2		NO ADDITIONAL CHARGE	
<b>Carrier, Spare Wheel: Inside Mounted.</b>				
LH Side .....	P14	N.A.	28.00	28.00
RH Side .....	P15	N.A.	28.00	28.00
<b>Doors, Rear:</b> Replacing standard double doors with 38" opening.				
60" opening. With strap hinges .....	E76	N.A.	87.00	87.00
66" opening. Overhead rear door with glass. Available on E34 Steel Hi-Cube Van only .....	E46	N.A.	442.00	442.00
74" opening with strap hinges. Available on E31, E34 or E38 Steel Hi-Cube Van only .....	E79	N.A.	195.00	195.00
78" opening. Overhead rear door with glass. Available on E31 or E38 Steel Hi-Cube Van only .....	E46	N.A.	442.00	442.00
85" opening. Overhead rear door with glass. Available on E36 or E39 Aluminum Hi-Cube Van only .....	E46	N.A.	442.00	442.00
87" Opening. Includes door glass. Available on E36 or E39 Aluminum Body Hi-Cube Van only .....	E53	N.A.	233.00	233.00
<b>Lock, Rear Door: Slam Type.</b> Available on E36 or E39 Aluminum Hi-Cube Van only. Not available when E46 Overhead Door is specified .....				
	AX9	N.A.	69.00	69.00
<b>Partitions: Expanded Metal.</b>				
Center Sliding Door .....	AX7	N.A.	378.00	378.00
Left-Hand Side only .....	AX5	N.A.	150.00	150.00
<b>Partition, Plywood: With Center Sliding Door .....</b>				
	AP7	N.A.	240.00	240.00
<b>Ventilator: Roof. Crank Type .....</b>				
	C55	N.A.	102.00	102.00

*For special body work not covered by the above options, refer to Union City Body Company Sales Department. Subsequent installation and payment for such special body work will be handled between the body company and the dealer.*

(a) D & H Charges on vehicle and optional equipment include reimbursement to ordering Division for any tax that it has paid, incurred or agreed to pay thereon.  
 ◇ State and local taxes not included.

# NOTES

**CUTAWAY VAN & HI-CUBE VAN  
RALLY CAMPER SPECIAL, VANDURA SPECIAL & MAGNAVAN**

**CAB & BODY FEATURES  
CHASSIS FEATURES  
COLOR & TRIM CHARTS  
TWO-TONES**



# CUTAWAY VAN RALLY CAMPER SPECIAL & VANDURA SPECIAL

## STANDARD MODEL—BODY ORDERING CODE—ZW9

The standard model includes the following items as standard equipment

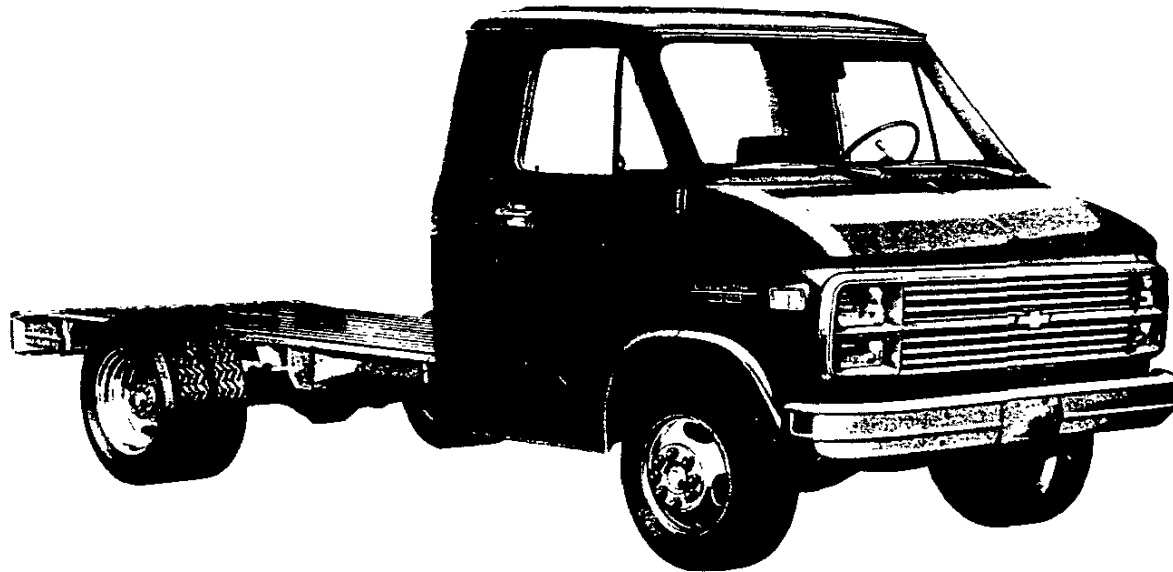

### EXTERIOR

- **Bumper:** Front only; painted silver (Model G31632 has chrome front bumper)
- **Colors:** See Interior and Exterior Color Selection Chart
- **Doors:** RH and LH front side doors
- **Door Opening and Locking Methods:**  
Outside pushbutton latch release in door handle with separate key lock; depression of inside pushbutton provides keyless outside locking feature
- **Glass:** Windshield; RH and LH front side door drop glass and pivoting ventpanes
- **Grille:** Molded plastic; painted light argent; integral Chevrolet emblem/GMC letters at center
- **Grille Frame:** Headlamp/parking lamp bezels plus upper and lower moldings joining extensions of lamp bezels; painted light argent
- **Horn:** Single, electric low-note (Models G31332, G31632 have second high note horn)
- **Hub Caps:** Bright metal with black trim (single rear wheel 125" WB only)
- **Keys:** Two-key system, with separate keys for ignition switch and door locks
- **Lights:**  
Headlamps: Two; Rectangular  
Combination parking/direction/hazard: Two front  
Side marker lamps with reflectors: Two front  
*NOTE: Wiring for rear lamps is included; with body portion coiled and wrapped*
- **Nameplates:** Bright "Chevy Van/Vandura" name and series plates on front fenders
- **Undercoating:** On step panels and front wheelhousings
- **Wheels:** Painted white
- **Windshield Wipers and Washers:** Electric, 2-speed wipers with matte finish on exposed metal portions; wet-arm design demand-type washer system

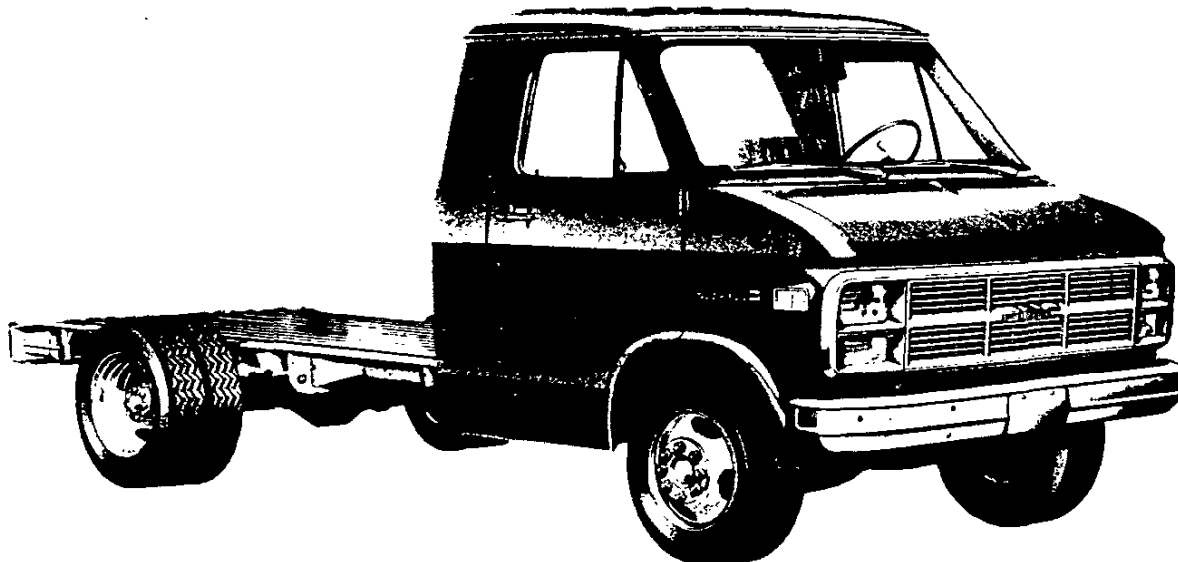

# CUTAWAY VAN RALLY CAMPER SPECIAL & VANDURA SPECIAL

## STANDARD MODEL—BODY ORDERING CODE—ZW9

The standard model includes the following items as standard equipment

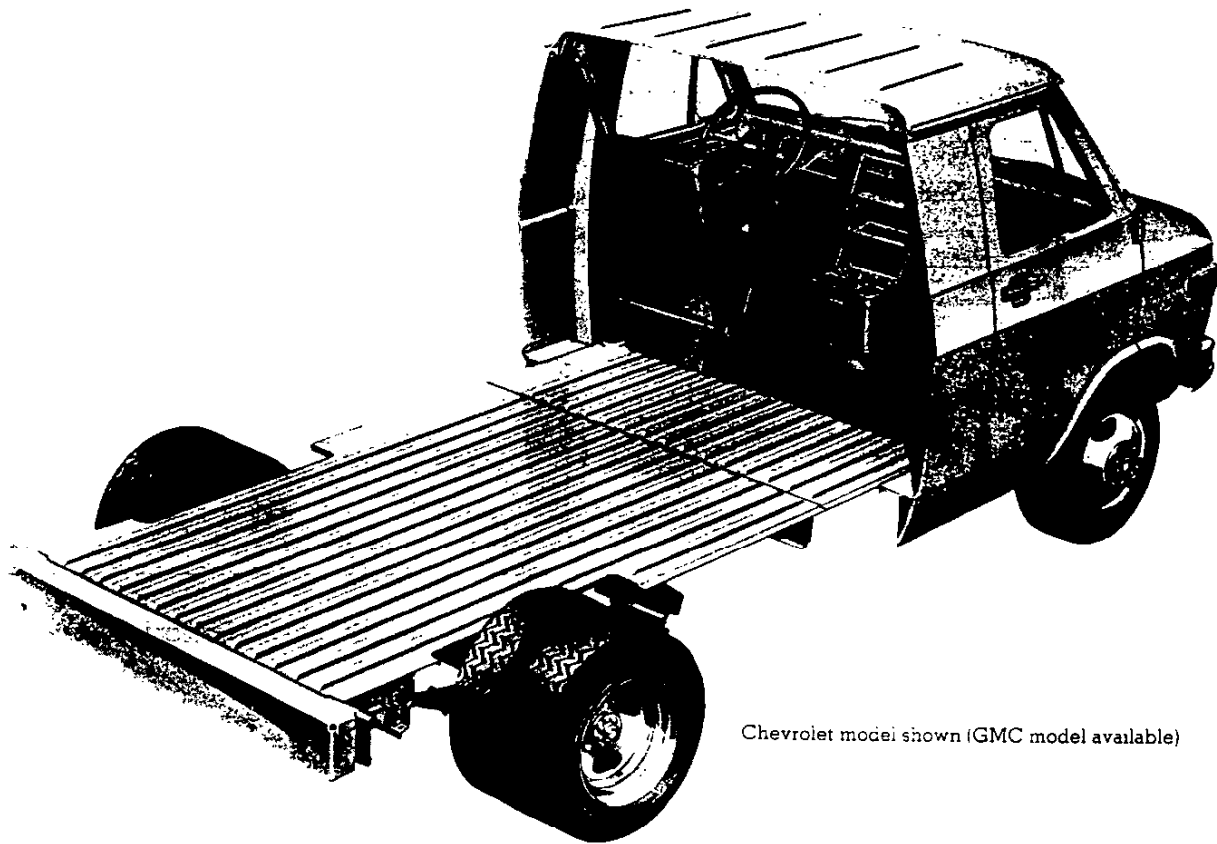

Chevrolet model shown (GMC model available)

### INTERIOR

- **Air Vents:** RH and LH; individually controlled
- **Armrest:** LH side door; padded
- **Ashtray:** At top of instrument panel extension; with door
- **Cigar Lighter:** RV Cutaway Van/Rally Camper Special models only; includes ash tray light
- **Colors:**  
Painted areas: Same as exterior primary color choice  
Interior trim: Coordinated with seat trim color choice
- **Dome Lamp:** In front compartment area.
- **Door Locks:** Inside pushbutton lock/release
- **Door Seals:** Latex foam rubber
- **Floor Covering:** Embossed black rubber mats on entire front floor area and wheelhousings
- **Headliner:** Mystic colored perforated hardboard with insulator (except Model G31332)
- **Heater and Defogger:** Deluxe-air
- **Hood Lock Release:** Handle located on LH side of instrument panel
- **Instruments:**  
Gages: Speedometer, odometer, and fuel (Model G31632 RV Cutaway Van/Rally Camper Special also has voltmeter, oil pressure gage, and engine temperature gage)  
Switches: Main, for control of exterior lights, dome light and instrument lights; multi-function switch on steering column for direction signals by moving lever up or down (includes lane change position), headlight beams by pulling lever toward driver, windshield wiper by turning band marked "WIPER" toward or away from driver, and windshield washer by pushing in the lever knob; ignition with key-in warning buzzer; hazard warning; heater fan; door-operated dome light (except Model G31332)

- Warning lights: Generator, oil pressure, engine temperature (except Model G31632—see "gages" above), service-parking brake, direction/hazard signal, and high beam
- **Instrument Panel:** Bright trim on gage bezels; black applique with bright trim on area below instrument cluster
- **Insulation and Sound Deadening Material:** Dash (firewall), entire front floor panel (except wheelhousings), inside engine cover, on engine cover front extension and under headliner (except Model G31332)
- **Lights:** Instrument and dome (except Model G31332)
- **Main Light Switch Control Knob:** Bright, with brushed finish and black graphic identification
- **Mirror, Rearview:** 10" prismatic with soft vinyl rim
- **Parcel Tray:** On top surface of instrument panel extension; includes beverage holder provisions
- **Safety Step Pads:** Front door step panels
- **Seat:** Front bucket, driver; all-vinyl trim; foam padded, adjustable. Also available at extra cost: High back driver and passenger seats in standard vinyl or custom vinyl. See Interior and Exterior Color Selection Chart for color and trim availability
- **Seat Belt:** Color-keyed with pushbutton release and outboard retractor
- **Steering Wheel and Column:** 15.25" diameter black soft vinyl wheel with 2 spokes; black energy-absorbing steering column with anti-theft locking feature
- **Storage Box:** In front face of instrument panel extension; with door
- **Sunshades:** LH padded, color-keyed
- **Trim Panels:** Painted metal with decorative embossments; front side doors

# HI-CUBE VAN/MAGNAVAN

## CUSTOM FEATURES—STANDARD MODEL

The standard model includes all items listed for the ZW9 Cutaway Van model plus the following additions or substitutions

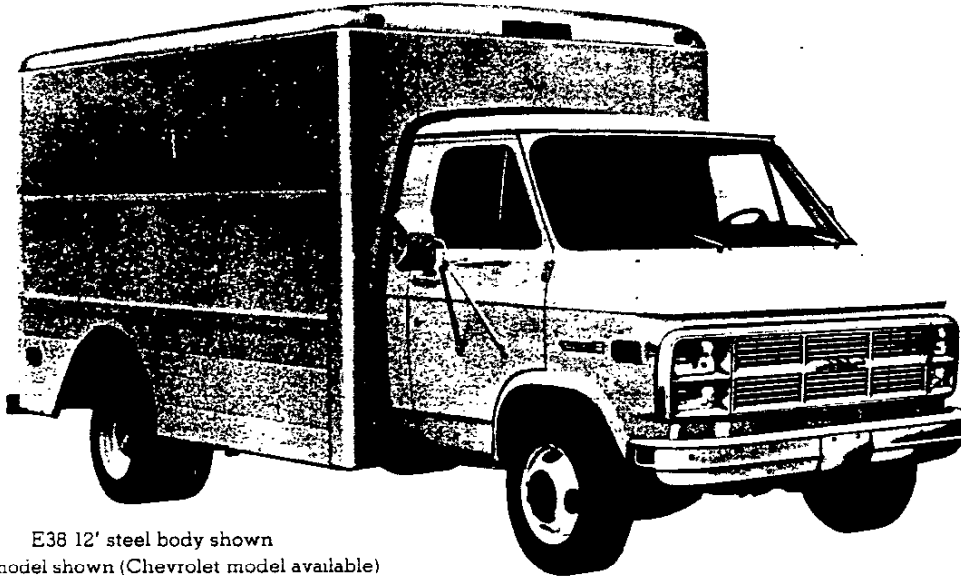

E38 12' steel body shown  
GMC model shown (Chevrolet model available)

### EXTERIOR

- **Body Panels and Framing:**  
With E31, E34 or E38 steel van body: Steel body panels, framing, and floor  
With E36 or E39 aluminum van body: Aluminum body panels and framing; steel floor
- **Bumper, Rear:** Step type; painted black
- **Door Body Protective Bumpers:** Rubber; mounted at rear of body to prevent damage when opening rear doors
- **Door Opening and Locking Method (Rear Doors):** RH and LH rear panel doors with glass; RH door contains inside and outside turn-handle latch release with key lock cylinder in outside handle; LH door opened by inside release at top of door.
- **Hub Caps:** Model G31303 with E34 only
- **Identification Decal:** "Chevrolet/GMC" letters on roof above rear identification lamps
- **Lights:**  
Backup lamps: Two rear  
Combination tail/stop/direction/hazard: Two rear  
License plate lamps; Two rear  
Side marker lamps and reflectors: Two rear  
Amber front identification and clearance lamps: Five  
Red rear identification and clearance lamps: Five
- **Mirrors:** RH and LH; painted white
- **Undercoating:** On side panels below floor and on rear wheel-housings

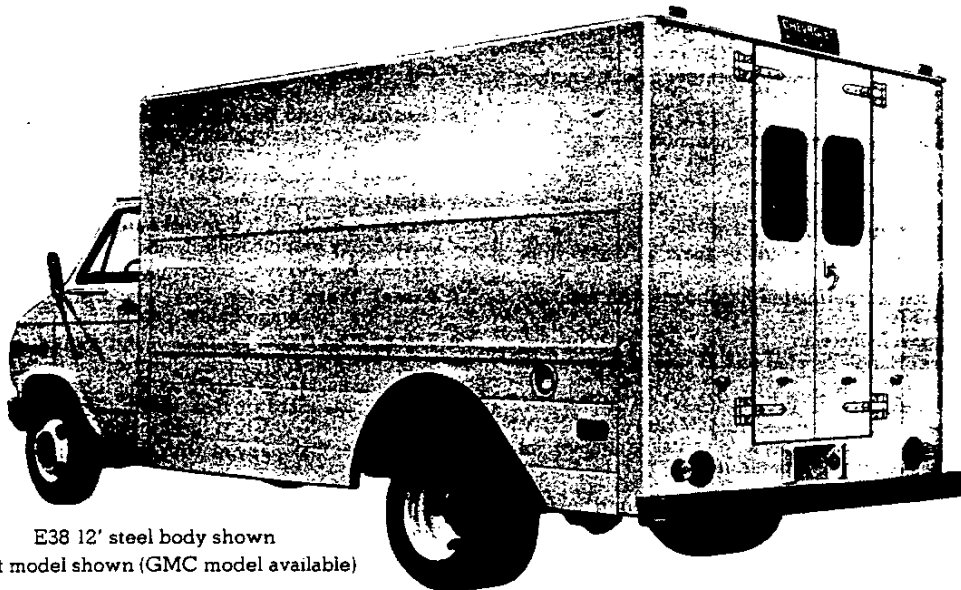

E38 12' steel body shown  
Chevrolet model shown (GMC model available)

# HI-CUBE VAN/MAGNAVAN

## CUSTOM FEATURES—STANDARD MODEL

The standard model includes all items listed for the ZW9 Cutaway Van model plus the following additions or substitutions

### INTERIOR—CAB

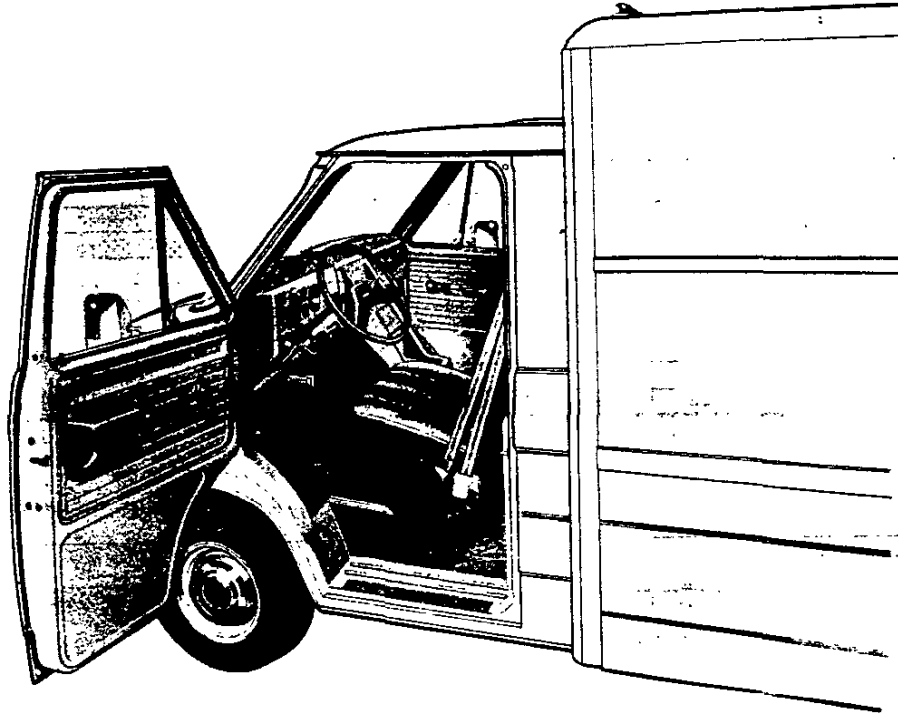

### INTERIOR—STEEL BODIES E31/E34/E38 (E38 12' steel body shown)

- **Cargo Area Lamp:** Activated via main light switch
- **Door Seals:** Closed cell sponge rubber
- **Floor:** 18-gage corrugated steel
- **Headliner:** Embossed steel; on entire interior roof area

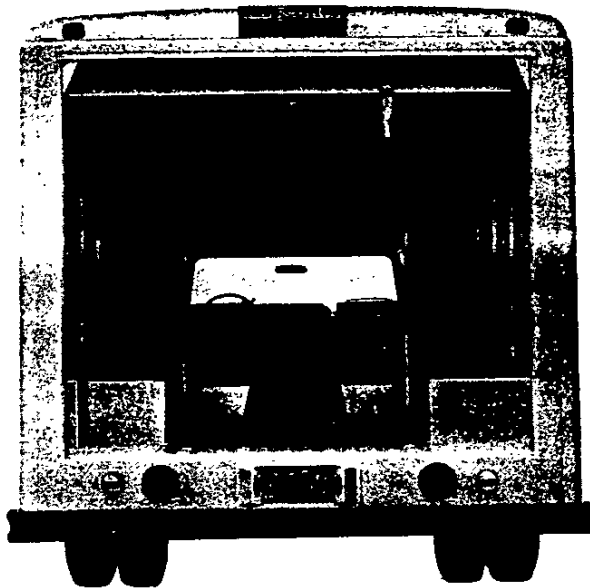

Optional 78" roll-up rear door shown in illustration  
GMC model shown (Chevrolet model available)

### INTERIOR—ALUMINUM BODIES E36/E39 (E39 12' aluminum body shown)

- **Cargo Area Lamp:** Activated via main light switch
- **Floor:** 18-gage corrugated steel

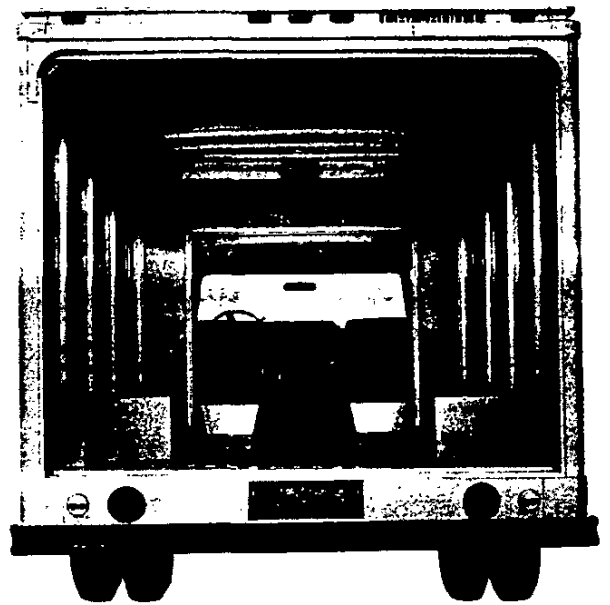

Optional 85" roll-up rear door shown in illustration  
Chevrolet model shown (GMC model available)

# CUTAWAY VAN & HI-CUBE VAN RALLY CAMPER SPECIAL, VANDURA SPECIAL & MAGNAVAN INTERIOR AND EXTERIOR COLOR AVAILABILITY CHART

**Please Note:** Below are the interior trim color and exterior paint combinations recommended by Chevrolet/GMC. The only available primary/secondary exterior color combinations are those shown in the chart below; however, any available interior trim color may be ordered with one of these exterior color combinations if that particular combination is desired by the customer.

INTERIOR COLORS		Decor	Black	Blue	Burgundy	Mahogany	Saddle Tan	Slate Gray
<b>STANDARD MODEL</b> (Two Seats w/A57)		Std.						
Vinyl Driver's Seat				VDD2			VSS2	
Vinyl High Back Bucket Driver's Seat				VDD4			VSS4	
Custom Vinyl High Back Bucket Driver's Seat			XBB4	XDD4	XEE4		XSS4	XTT4
<b>SPECIAL INTERIOR</b> (Includes Two Seats)		273						
Custom Vinyl High Back Bucket Seats				XDD4	XEE4		XSS4	XTT4
Custom Cloth High Back Bucket Seats				KDD4	KEE4	KNN4	KSS4	KTT4
EXTERIOR COLORS		Primary	Secondary	RECOMMENDED INTERIOR TRIM COLORS				
BLUE, LIGHT (Metallic)	21	21		X				X
BLUE, GALAXY (Metallic)	28	28		X				X
BRONZE, INDIAN (Metallic)	66	66				X	X	
RED, APPLE	72	72			X		X	
RED, AUTUMN (Metallic)	76	76			X			
SAND, DESERT (Metallic)	64	64				X	X	
SILVER (Metallic)	16	16	X	X	X			X
TAN, DOESKIN	61	61				X	X	
WHITE, FROST	12	12	X	X	X	X	X	X
WHITE, POLAR	93	93	X	X	X	X	X	X
YELLOW, COLONIAL	53	53				X	X	

## Paint Applications

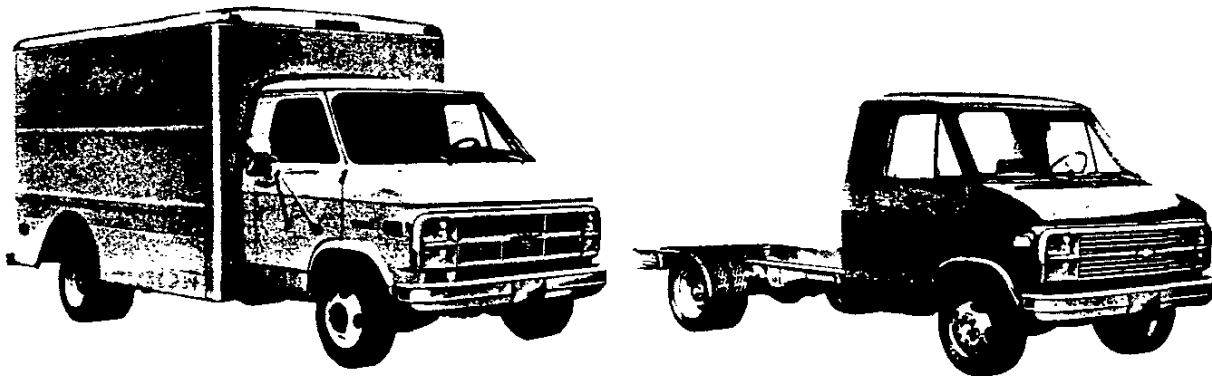

**Solid Color** paint (ZY1) is standard on Cutaway Vans and on steel Hi-Cube Van/Magnavan models and is available on aluminum Hi-Cube Van/Magnavan models. All painted areas of the cab or cab and van body are painted the same color.

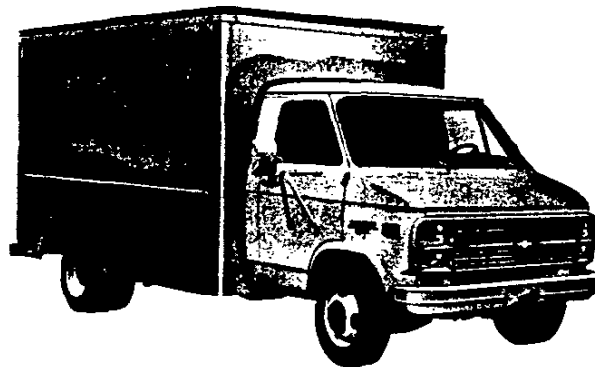

**Two-Tone** paint treatment (ZY2) is available on aluminum Hi-Cube Van/Magnavan models only. The cab is painted the selected primary color, and the aluminum van body is *unpainted*, bare aluminum (secondary color code 02 must be specified).

## STEP-VAN/VALUE VAN

### STEP-VAN/VALUE VAN & FC CHASSIS MODEL SELECTOR

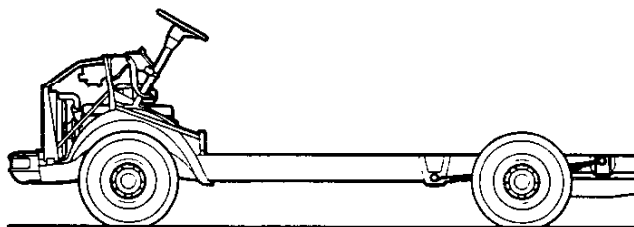

#### FC CHASSIS

Body Ordering Code—Gasoline Models—ZW9  
Body Ordering Code—Diesel Models—ZW9/B3J

SERIES	125" WB	133" WB	157" WB	178" WB
■P20/2500	P20842	P21042	—	—
P30/3500	P30842	P31042	P31442	P31842

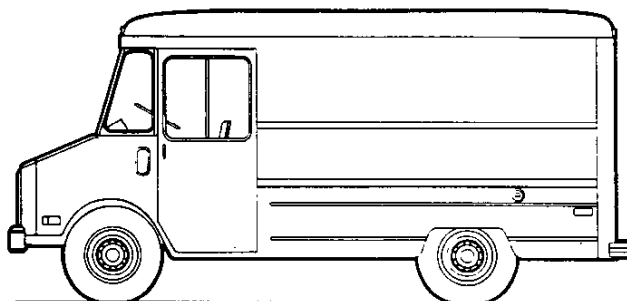

#### STEP-VAN/VALUE VAN—STEEL

Body Ordering Code—Gasoline Models—E32  
Body Ordering Code—Diesel Models—E32/B3J

SERIES	10'6" BODY	12'6" BODY	14'6" BODY
■P20/2500	P20842	P21042	—
P30/3500	P30842	P31042	P31442

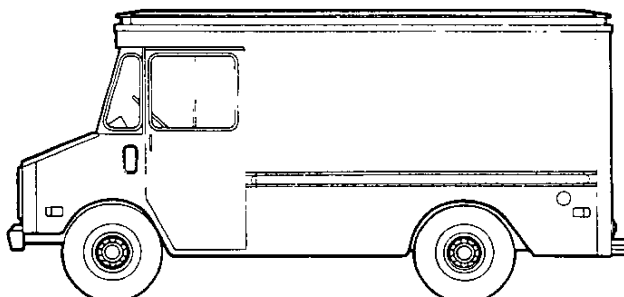

#### STEP-VAN/VALUE VAN—ALUMINUM

Body Ordering Code—Gasoline Models—E33  
Body Ordering Code—Diesel Models—E33/B3J

SERIES	10'6" BODY	12'6" BODY	14'6" BODY	18' BODY
■P20/2500	P20842	P21042	—	—
P30/3500	P30842	P31042	P31442	P31842

■P20/2500 models not available for registration in the State of California.

**GASOLINE**

## STEP-VAN/VALUE VAN

### STANDARD SPECIFICATIONS

(See Gray Tab Section for Specification Details)

Series	■P20/2500	P30/3500 (except P31842)	P31842
<b>Engine</b>	4.8 Liter, 292 l-bbl L6		
<b>Base Equip.</b> .....	11," 124 sq. in.		
<b>Clutch</b> .....	Poly-wrapped Oiled-paper Element		
<b>Air Filter</b> .....	Throwaway Type		
<b>Oil Filter</b> .....	Single; Aluminized		
<b>Exhaust System</b> .....	See Engine & Cooling Section for specific model application		
<b>Emission Control Systems</b> .....			
<b>Suspension, Front</b>	Independent; Coil Springs		
<b>Capacity</b> .....	3700 lb.	4000 lb.	4000 lb.
<b>Springs @ Ground</b> .....	1800 lb. ea.	2200 lb. ea.	2200 lb. ea.
<b>Shock Absorbers</b> .....	32mm dia.		
<b>Stabilizer Bar</b> .....	1.25" dia.		
<b>Suspension, Rear</b>	Salisbury Axle; Hypoid Drive; Two-stage Multi-leaf Springs		
<b>Axle Capacity</b> .....	5700 lb.	7900 lb.	7900 lb.
<b>Axle Ratio</b> .....	3.73	4.56	5.13
<b>Springs @ Ground</b> .....	2200 lb. ea.	3100 lb. ea.	4000 lb. ea.
<b>Shock Absorbers</b> .....	32mm dia.		
<b>Brakes</b>	Hydraulic; Self-adjusting		
<b>Front</b> .....	Disc; 12.5" Rotor		
<b>Rear</b> .....	Drum; 11.15" x 2.75"	Drum; 13" x 2.5"	Drum; 13" x 3.5"
<b>Booster</b> .....	Dual Diaphragm	Dual Diaphragm	Hydraulic Power
<b>Parking</b> .....	Cable to Rear Wheels		
<b>Electrical</b>	12 Volt; Negative Ground		
<b>Battery - Freedom Type</b> .....	390 CCA ♦ @ 0°F.		
<b>- Reserve Capacity</b> .....	90 min. @ 80°F.		
<b>Delcotron Generator</b> .....	42 amp.		
<b>Frame</b>	Carbon Steel; 36,39,000 psi		
<b>Section Modulus</b> .....	5.26	125," 133" WB-5.26 157" WB-6.12	6.12
<b>Fuel Tank (nominal capacity)</b>	40 gal.		
<b>Steering Gear Type</b>	Integral Power		
<b>Transmission</b>	4-Speed Manual		
<b>Shift Location</b> .....	Floor		
<b>Tires - Front</b> .....	(2) LT215/85R16C (6PR)	(2) LT215/85R16C (6PR)	(2) LT215/85R16C (6PR)
<b>- Rear</b> .....	(2) LT215/85R16C (6PR)	(2) LT215/85R16D (8PR)	(4) LT215/85R16C (6PR)
<b>Wheels</b>	(4) Disc 16" x 6.5"	(4) Disc 16" x 6.5"	(6) Disc 16" x 6.0"

■P20/2500 models not available for registration in the State of California.

♦CCA - Cold Cranking Amps

# STEP-VAN/VALUE VAN

## STANDARD SPECIFICATIONS

**DIESEL**

(See Gray Tab Section for Specification Details)

Series	■P20/2500	P30/3500 (except P31842)	P31842
<b>Engine</b>			
<b>Base Equip.</b> .....	6.2 Liter, 379 Cu. In. V8 Diesel		
<b>Clutch</b> .....	12," 150 sq. in.		
<b>Air Filter</b> .....	Poly-wrapped Oiled-paper Element		
<b>Oil Filter</b> .....	Throwaway Type		
<b>Oil Cooler</b> .....	Standard		
<b>Exhaust System</b> .....	Dual; Aluminized		
<b>Emission Control Systems</b> .....	See Engine & Cooling Section for specific model application		
<b>Suspension, Front</b> .....	Independent; Coil Springs		
<b>Capacity</b> .....	3700 lb.	4000 lb.	4000 lb.
<b>Springs @ Ground</b> .....	1800 lb. ea.	2200 lb. ea.	2200 lb. ea.
<b>Shock Absorbers</b> .....	32mm dia.		
<b>Stabilizer Bar</b> .....	1.25" dia.		
<b>Suspension, Rear</b> .....	Salisbury Axle; Hypoid Drive; Two-stage Multi-leaf Springs		
<b>Axle Capacity</b> .....	5700 lb.	7900 lb.	7900 lb.
<b>Axle Ratio</b> .....	3.73	3.73	4.10
<b>Springs, Main @ Ground</b> .....	2200 lb. ea.	3100 lb. ea.	4000 lb. ea.
<b>Shock Absorbers</b> .....	32mm dia.		
<b>Brakes</b> .....	Hydraulic; Self-adjusting		
<b>Front</b> .....	Disc; 12.5" Rotor		
<b>Rear</b> .....	Drum; 11.15" x 2.75"	Drum; 13" x 2.5"	Drum; 13" x 3.5"
<b>Booster</b> .....	Hydraulic Power		
<b>Parking</b> .....	Cable to Rear Wheels		
<b>Electrical</b> .....	12 Volt; Negative Ground		
<b>Battery—Freedom Type</b> .....	Two; 550 CCA ♦ ea. @ 0°F.		
<b>— Reserve Capacity</b> .....	115 min. ea. @ 80°F.		
<b>Delcotron Generator</b> .....	66 amp.		
<b>Engine Block Heater</b> .....	600 watts, 120 volts		
<b>Frame</b> .....	Carbon Steel; 36-39,000 psi		
<b>Section Modulus</b> .....	5.26	125," 133" WB—5.26 157" WB—6.12	6.12
<b>Fuel Tank (nominal capacity)</b> .....	40 gal.		
<b>Steering Gear Type</b> .....	Integral Power		
<b>Transmission</b> .....	4-Speed Manual		
<b>Shift Location</b> .....	Floor		
<b>Tires—Front</b> .....	*(2) LT215/85R16C (6PR)	(2) LT215/85R16C (6PR)	(2) LT215/85R16C (6PR)
<b>—Rear</b> .....	*(2) LT215/85R16C (6PR)	(2) LT215/85R16D (8PR)	(4) LT215/85R16C (6PR)
<b>Wheels</b> .....	(4) Disc 16" x 6.5"	(4) Disc 16" x 6.5"	(6) Disc 16" x 6.0"

■P20/2500 models not available for registration in the State of California.

♦CCA—Cold Cranking Amps

\*Steel body (E32/B3J) Step-Van models have D (8PR) tires.



**GASOLINE**

**STEP-VAN/VALUE VAN**  
**P20/2500-30/3500 SERIES—FC CHASSIS**

Body Ordering Code—ZW9

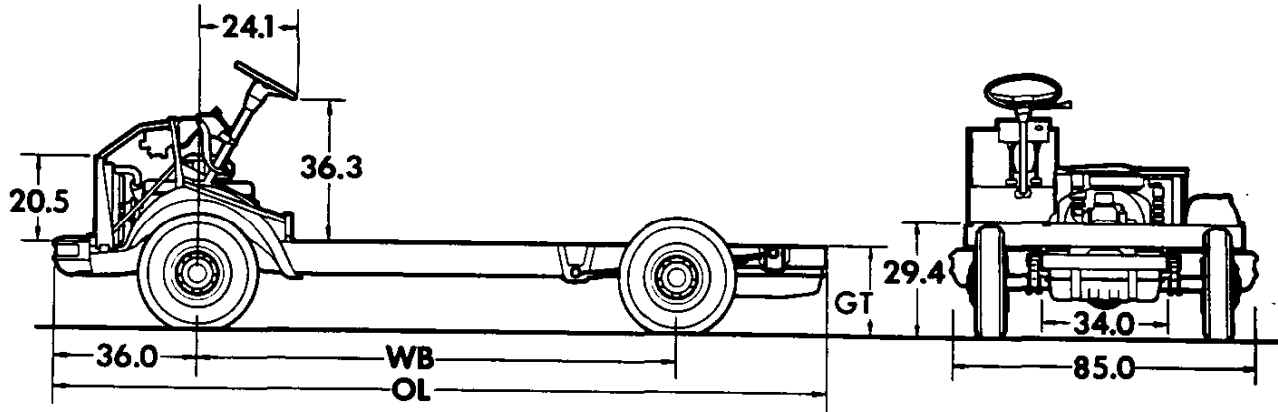

Model	Engine No. Cyl.	Dimensions (in)*			Curb Weight (lb)†			Ground Clearance (in)*	
		WB	OL	GT	Front	Rear	Total	Front	Rear

**■P20/2500 SERIES**

<b>P20842</b>	6	125	214.8	27.9	1868	1290	3158	8.5	6.9
<b>P21042</b>	6	133	238.8	27.9	1869	1302	3171	8.5	6.9

**P30/3500 SERIES**

<b>P30842</b>	6	125	214.8	29.1	1878	1418	3296	8.8	7.2
<b>P31042</b>	6	133	238.8	29.1	1882	1435	3317	8.8	7.2
<b>P31442</b>	6	157	262.8	29.1	1945	1480	3425	8.8	7.2
<b>P31842</b>	6	178	318.4	29.1	2009	1847	3856	8.8	7.2

\*Dimensions with standard equipment, unloaded.

†Total Curb Weight may vary as much as  $\pm 50$  lbs. to allow for production build variation.

■P20/2500 models not available for registration in the State of California.

# STEP-VAN/VALUE VAN

## P20/2500-30/3500 SERIES—FC CHASSIS

**DIESEL**

Body Ordering Code—ZW9/B3J

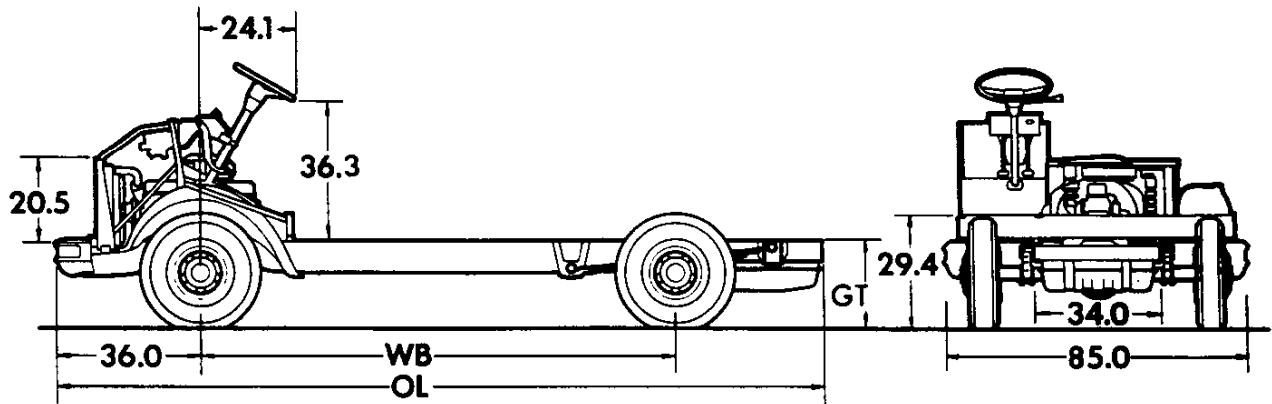

Model	Engine No. Cyl.	Dimensions (in) <sup>*</sup>			Curb Weight (lb) <sup>†</sup>			Ground Clearance (in) <sup>*</sup>	
		WB	OL	GT	Front	Rear	Total	Front	Rear

### ■ P20/2500 SERIES

<b>P20842</b>	8	125	214.8	27.9	2192	1276	3468	8.5	6.9
<b>P21042</b>	8	133	238.8	27.9	2193	1285	3478	8.5	6.9

### P30/3500 SERIES

<b>P30842</b>	8	125	214.8	29.1	2202	1404	3606	8.8	7.2
<b>P31042</b>	8	133	238.8	29.1	2206	1418	3624	8.8	7.2
<b>P31442</b>	8	157	262.8	29.1	2284	1460	3744	8.8	7.2
<b>P31842</b>	8	178	318.4	29.1	2338	1934	4272	8.8	7.2

<sup>\*</sup>Dimensions with standard equipment, unloaded.

<sup>†</sup>Total Curb Weight may vary as much as  $\pm 50$  lbs. to allow for production build variation.

■ P20/2500 models not available for registration in the State of California.

**GASOLINE**

**STEP-VAN/VALUE VAN**  
**STEP-VAN/VALUE VAN—STEEL BODY**

Body Ordering Code—E32

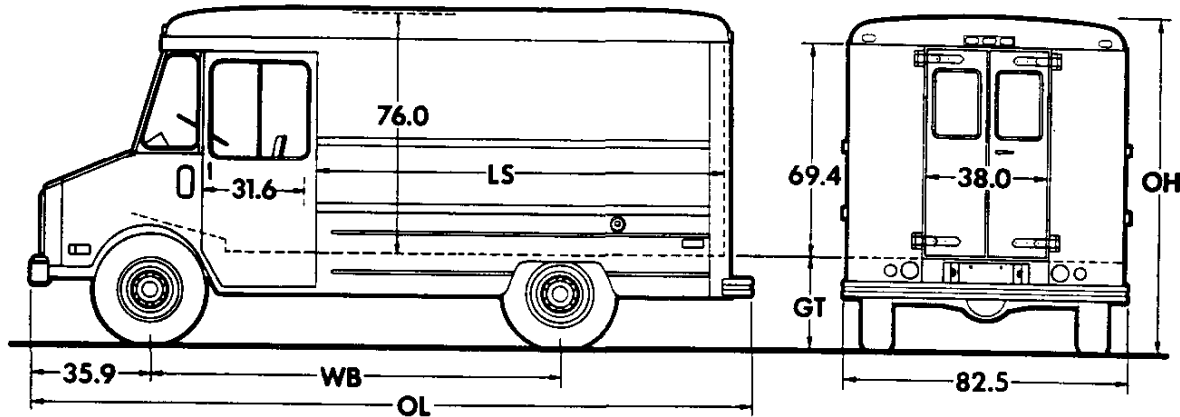

Series	Ground Clearance (in)★	
	Front	Rear
P2	8.5	6.9
P3	8.8	7.2

Model	Engine No. Cyl.	Dimensions (in)★					Curb Weight (lb)			Model Weight (lb)†			Body-Payload Wt. Dist.‡	
		WB	OL	LS	OH	GT	Front	Rear	Total	Front	Rear	Total	% Front	% Rear

**■P20/2500 SERIES**

<b>P20842</b>	6	125	226.8	128	109.5	26.9	2729	3131	5860	2838	3172	6010	9	91
<b>P21042</b>	6	133	250.8	152	109.5	26.7	2837	3285	6122	2949	3323	6272	6	94

**■P30/3500 SERIES**

<b>P30842</b>	6	125	226.8	128	109.5	27.2	2739	3259	5998	2848	3300	6148	9	91
<b>P31042</b>	6	133	250.8	152	109.5	27.2	2851	3418	6269	2963	3456	6419	6	94
<b>P31442</b>	6	157	274.8	176	109.5	26.9	3085	3535	6620	3203	3567	6770	12	88

★Dimensions with standard equipment, unloaded.

†Model Weight includes Curb Weight plus occupants (standard seating capacity x 150 lb). Total Model Weight may vary as much as ±50 lbs. to allow for production build variation.

\*Estimate based on water-level loading.

■P20/2500 models not available for registration in the State of California.

# STEP-VAN/VALUE VAN

## STEP-VAN/VALUE VAN—STEEL BODY

**DIESEL**

Body Ordering Code—E32

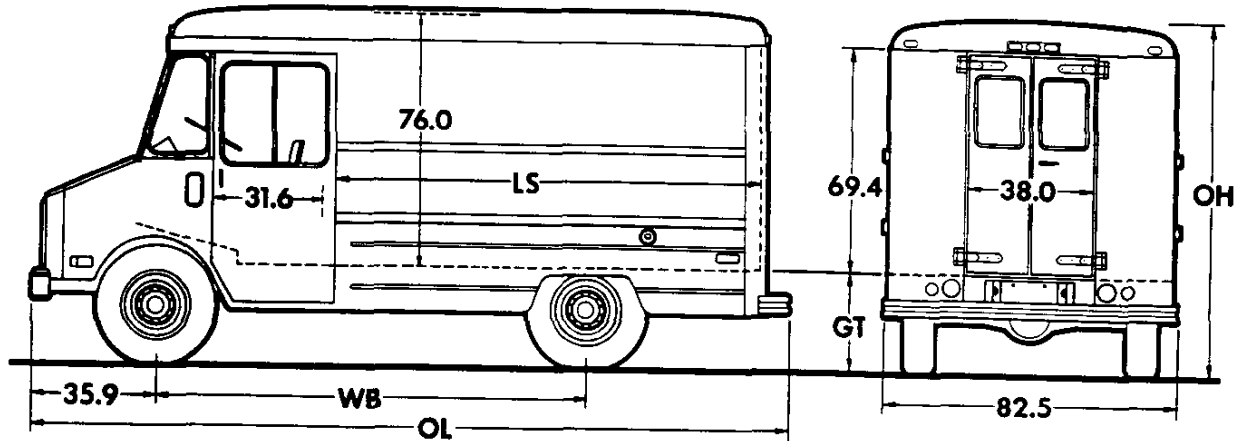

Series	Ground Clearance (in)★	
	Front	Rear
P2	8.5	6.9
P3	8.8	7.2

Model	Engine No. Cyl.	Dimensions (in)★					Curb Weight (lb)			Model Weight (lb)†			Body-Payload Wt. Dist.‡	
		WB	OL	LS	OH	GT	Front	Rear	Total	Front	Rear	Total	% Front	% Rear
<b>■P20/2500 SERIES</b>														
<b>P20842</b>	6	125	226.8	128	109.5	26.9	3137	3094	6231	3246	3135	6381	9	91
<b>P21042</b>	6	133	250.8	152	109.5	26.7	3244	3248	6492	3356	3286	6642	6	94
<b>■P30/3500 SERIES</b>														
<b>P30842</b>	6	125	226.8	128	109.5	27.2	3147	3210	6357	3256	3251	6507	9	91
<b>P31042</b>	6	133	250.8	152	109.5	27.2	3258	3369	6627	3370	3407	6777	6	94
<b>P31442</b>	6	157	274.8	176	109.5	26.9	3501	3487	6988	3619	3519	7138	12	88

★Dimensions with standard equipment, unloaded.

†Model Weight includes Curb Weight plus occupants (standard seating capacity x 150 lb). Total Model Weight may vary as much as ±50 lbs. to allow for production build variation.

‡Estimate based on water-level loading.

■P20/2500 models not available for registration in the State of California.

**GASOLINE**

**STEP-VAN/VALUE VAN**  
**STEP-VAN/VALUE VAN—ALUMINUM BODY**

Body Ordering Code—E33

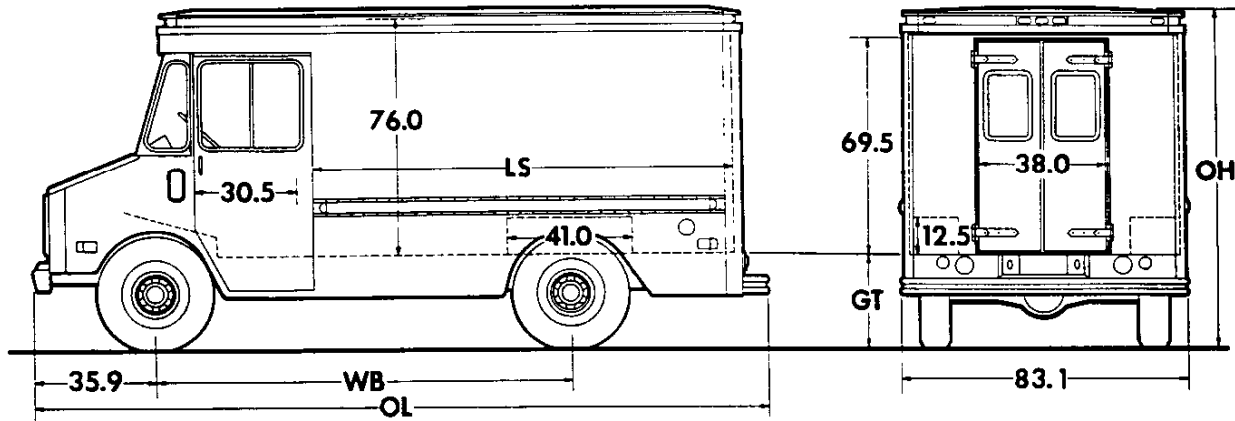

Series	Ground Clearance (in)★	
	Front	Rear
P20	8.5	6.9
P30	8.5	7

Model	Engine No. Cyl.	Dimensions (in)★					Curb Weight (lb)			Model Weight (lb)†			Body-Payload Wt. Dist.‡	
		WB	OL	LS	OH	GT	Front	Rear	Total	Front	Rear	Total	% Front	% Rear

**■P20/2500 SERIES**

<b>P20842</b>	6	125	226.8	129.6	110.0	27.4	2347	2492	4839	2456	2533	4989	9	91
<b>P21042</b>	6	133	250.8	153.6	110.0	27.2	2421	2507	4928	2533	2545	5078	6	94

**P30/3500 SERIES**

<b>P30842</b>	6	125	226.8	129.6	110.0	27.8	2357	2620	4977	2466	2661	5127	9	91
<b>P31042</b>	6	133	250.8	153.6	110.0	27.8	2435	2640	5075	2547	2678	5225	6	94
<b>P31442</b>	6	157	274.8	177.6	110.0	27.7	2553	2876	5429	2671	2908	5579	12	88
<b>P31842</b>	6	178	316.7	219.6	110.0	27.5	2706	3357	6063	2818	3395	6213	10	90

★Dimensions with standard equipment, unloaded.

†Model Weight includes Curb Weight plus occupants (standard seating capacity x 150 lb). Total Model Weight may vary as much as ±50 lbs. to allow for production build variation.

‡Estimate based on water-level loading.

■P20/2500 models not available for registration in the State of California.



# STEP-VAN/VALUE VAN

## POWER TEAMS

### ALL STATES EXCEPT CALIFORNIA

#### P20/2500 SERIES

**POWER TEAMS (MUST ORDER ENGINE, TRANSMISSION AND REAR AXLE)**  
(Consult GVWR Selector and Tire Chart to insure tire capacity and availability)

#### W/NA5 STANDARD OR NA6 HIGH ALTITUDE EMISSION EQUIPMENT

ENGINE	TRANSMISSION		AXLES				GVWR
	4-SP	AUTO	3.73	*4.10			
#L25 L6 4.8 Liter (292-1BBL)	MM4		GQ1	*GT5			6800
	MM4		—	*GQ1			75/8000
#LT9 V8 5.7 Liter (350-4 BBL)	MM4	MX1	GQ1	*GT5			ALL
■LL4 Diesel 6.2 Liter V8 (379 Cu. In.)(Reqs B3J)	MM4	MX1	GQ1	*GT5			6800
	MM4	MX1	GQ1	*GT5			7500
	MM4	MX1	GQ1	*GT5			8000

\*N/A G80 Locking Differential  
#N/A NA6 High Altitude Emissions. With NA5 Emissions  
Satisfies High Altitude Requirements

#### P30/3500 SERIES

**POWER TEAMS (MUST ORDER ENGINE, TRANSMISSION AND REAR AXLE)**  
(Consult GVWR Selector and Tire Chart to insure tire capacity and availability)

#### W/NA5 STANDARD OR NA6 HIGH ALTITUDE EMISSIONS

ENGINE	TRANSMISSION		AXLES					#GVWR
	4-SP	AUTO	3.73	*4.10	4.56	*5.13	*5.29	
§L25 L6 4.8 Liter (292-1BBL)	MM4	MX1	—	*GT5	GQ1	—	—	7600
	MM4	MX1	—	—	GQ1	—	—	8200
	MM4	MX1	—	—	GQ1	—	—	9000
	MM4	MX1	—	—	HC4	*GQ1	—	**9000
	MM4	MX1	—	—	HC4	*GQ1	—	10000
	MM4	MX1	—	—	—	*GQ1	—	11500
§LT9 V8 5.7 Liter (350-4BBL)	MM4	MX1	GQ1	*GT5	—	—	—	76/8200
	MM4	MX1	—	*GQ1	HC4	—	—	9/10000
	MM4	MX1	—	—	GQ1	—	—	11500
	MM4	MX1	—	—	—	—	§HA3	12/14000
	MM4	MX1	—	—	—	—	§HA3	14500
■LL4 Diesel 6.2 Liter V8 (379 Cu. In.)(Reqs B3J)	MM4	MX1	GQ1	*GT5	—	—	—	7600
	MM4	MX1	—	*GQ1	HC4	—	—	8200
	MM4	MX1	—	*GQ1	HC4	—	—	9/10000
	MM4	MX1	—	—	GQ1	*HC7	—	11500
	MM4	MX1	—	—	—	—	*HA3	12/14000
	MM4	MX1	—	—	—	—	*HA3	14500

#Consult GVWR Selector for availability and restrictions  
\*N/A G80 Locking Differential  
\*\*Reqs R05 Wheels  
§N/A G80 Locking Differential. (Reqs KC4 Cooler)  
(w/MM4 Trans Reqs V01 Cooling System)  
§§N/A NA6 High Altitude Emissions. With NA5 Emissions  
Satisfies High Altitude Requirements

■ High Altitude Emission Equipment (FOR EXHAUST SMOKE REDUCTION PURPOSES  
AT HIGH ALTITUDE; NOT REQUIRED TO SATISFY HIGH ALTITUDE EMISSION REGULATIONS).

2025  
SEP 1983

# STEP-VAN/VALUE VAN

## POWER TEAMS CALIFORNIA ONLY

### P30/3500-SERIES

### POWER TEAMS (MUST ORDER ENGINE, TRANSMISSION AND REAR AXLE)

(Consult GVWR Selector and Tire Chart to insure tire capacity and availability)

W/ YF5 CALIFORNIA EMISSIONS

W/ YF5 CALIFORNIA EMISSIONS									
ENGINE	TRANSMISSION			AXLES					#GVWR
	4-SP	AUTO		3.73	*4.10	4.56	*5.13	*5.29	
\$\$L25 L6 4.8 Liter (292-1BBL)	MM4	MX1		—	*GT5	GQ1	—	—	7600
	MM4	MX1		—	—	GQ1	—	—	8200
	MM4	MX1		—	—	GQ1	—	—	9000
	MM4	MX1		—	—	HC4	*GQ1	—	**9000
	MM4	MX1		—	—	HC4	*GQ1	—	10000
\$\$LT9 V8 5.7 Liter (350-4BBL)	MM4	MX1		GQ1	*GT5	—	—	—	76/8200
	MM4	MX1		—	*GQ1	HC4	—	—	9/10000
	MM4	MX1		—	—	GQ1	—	—	11500
	MM4	MX1		—	—	—	—	\$HA3	12/14000
	MM4	MX1		—	—	—	—	\$HA3	14500
LL4 Diesel 6.2 Liter V8 (379 Cu. In.)(Reqs B3J)	MM4	MX1		GQ1	*GT5	—	—	—	7600
	MM4	MX1		—	*GQ1	HC4	—	—	8200
	MM4	MX1		—	*GQ1	HC4	—	—	9/10000
	MM4	MX1		—	—	GQ1	*HC7	—	11500
	MM4	MX1		—	—	—	—	*HA3	12/14000
MM4	MX1		—	—	—	—	*HA3	14500	

#Consult GVWR Selector for availability and restrictions

\*N/A G80 Locking Differential

\*\*Reqs R05 Wheels

\$N/A G80 Locking Differential. (Reqs KC4 Cooler)  
(w/MM4 Trans Reqs V01 Cooling System)

\$\$N/A NA6 High Altitude Emissions. With NA5 Emissions  
Satisfies High Altitude Requirements

## ENGINE RATINGS

### ALL STATES EXCEPT CALIFORNIA

SAE Net Ratings	4.8 Liter 292 1-bbl L6	5.7 Liter 350 4-bbl V8	6.2 Liter 379 V8 Diesel
Net Horsepower	115 @ 3600 rpm	160 @ 3800 rpm	135 @ 3600 rpm
Net Torque, lb-ft	215 @ 1600 rpm	250 @ 2800 rpm	240 @ 2000 rpm

### CALIFORNIA ONLY

SAE Net Ratings	4.8 Liter 292 1-bbl L6	5.7 Liter 350 4-bbl V8	6.2 Liter 379 V8 Diesel
Net Horsepower	115 @ 3600 rpm	155 @ 4000 rpm	135 @ 3600 rpm
Net Torque, lb-ft	215 @ 1600 rpm	240 @ 2800 rpm	240 @ 2000 rpm



# STEP-VAN/VALUE VAN

## GVWR SELECTOR—ALL STATES EXCEPT CALIFORNIA

### P20/2500 SERIES (NOT AVAILABLE IN CALIFORNIA)

GVW Rating (lbs)	†GAWR (lbs)		Minimum Equipment Required for GVW Rating		
	Front	Rear	Tire Capacity (lbs ea)		Chassis Equipment
			Front	Rear	
●6800	3600	3880	1940	1940	Standard
7500	3880	4630	1940	2315	HD Rear Springs (G50); HD Power Brakes (J55)
8000	4000	5246	2623	2623	

†GAWR's shown are the maximum for each axle with equipment listed. Other GAWR's are available, and they are determined as the minimum capacity of either axle, springs or tires.

●Not available when E32 steel body is ordered with LL4 Diesel engine.

## FRONT AND REAR TIRE AVAILABILITY CHART—ALL STATES EXCEPT CALIFORNIA

Spare tire to match either front or rear tires available at extra cost  
P20/2500 SERIES

Description	Capacity (lbs ea)	Highway		On-Off Road	Spare
		Front	Rear	Rear	
<b>TUBELESS</b>					
LT215/85R16C	1940	XYJ	●YYJ	—	●ZYJ
LT215/85R16C	1940	XYJ	—	—	—
LT215/85R16D	2315	—	YYK	—	ZYK
		—	—	YYL YYL	ZYL ZYK
LT215/85R16D	2315	XYK	YYK	—	ZYK
		—	—	YYL YYL	ZYL ZYK
LT235/85R16D	2623	XYM	YYM	—	ZYM
<b>TUBE-TYPE</b>					
7.50-16C	2060	XPB	●YPB	—	ZPB
7.50-16C	2060	XPB	—	—	—
7.50-16D	2440	—	YPF	—	ZPF
		—	—	YPG YPG	ZPG ZPF
7.50-16E	2780	—	YPK	—	ZPK
7.50-16D	2440	XPF	YPF	—	ZPF
		—	—	YPG YPG	ZPG ZPF
7.50-16E	2780	XPK	YPK	—	ZPK

●Not available when E32 steel body is ordered with LL4 Diesel engine.

## STEP-VAN/VALUE VAN

### GVWR SELECTOR—ALL STATES

GVW Rating (lbs)	-GAWR (lbs)		Minimum Equipment Required for GVW Rating			
	Front	Rear	Tire Capacity (lbs ea)		Chassis Equipment	
			Front	Rear		

#### P30/3500 SERIES

♦ 7600	3880	4630	1940	2315	Standard
♦ 8200	4000	5246	2623	2623	
● 9000	4000	6084	3042	3042	HD Power Brakes (J55)
● 9000	3880	6200	1940	1764 (Dual)	Dual Rear Wheel Provisions (R05); HD Power Brakes (J55)
10,000	3880	7056	1940	1764 (Dual)	Dual Rear Wheel Provisions (R05); HD Rear Springs (G60); HD Power Brakes (J55)
10,000	3880	7056	1940	1764 (Dual)	Standard for P31842 only
● 11,500	3880	7900	1940	2105 (Dual)	Dual Rear Wheel Provisions (R05); HD Rear Springs (G60); School Bus Chassis Equipment (B3D)
‡12,000	4500	9840	2800	2460 (Dual)	11,000 lb Rear Axle (HA3)
‡14,000	4500	11,000	2800	2780 (Dual)	11,000 lb Rear Axle (HA3)
●‡14,500	4500	11,000	2800	2780 (Dual)	11,000 lb Rear Axle (HA3); School Bus Chassis Equipment (B3D)

+GAWR's shown are the maximum for each axle with equipment listed. Other GAWR's are available, and they are determined as the minimum capacity of either axle, springs or tires.

‡Requires V8 engine. ♦ Not available in California or on model P31842. ● Not available on model P31842.

#### FRONT AND REAR TIRE AVAILABILITY CHART—ALL STATES

Spare tire to match either front or rear tires available at extra cost  
P30/3500 SERIES

Description	Capacity (lbs each)		Highway			On-Off Road		Spare
	Front/ Single Rear	Dual Rear	Front	Single Rear	Dual Rear	Single Rear	Dual Rear	
<b>TUBELESS With 7900-lb Rear Axle</b>								
LT215/85R16C	1940	1764	XYJ	—	YYJ	—	—	ZYJ
LT215/85R16C	1940	—	XYJ	—	—	—	—	—
LT215/85R16D	—	2105	—	YYK	YYK	YYL	YYL	ZYK ZYL ZYK
LT215/85R16D	—	—	—	—	—	—	—	ZYK
LT215/85R16C	2315	—	XYK	—	YYJ	—	—	ZYK
LT215/85R16C	—	1764	—	—	—	—	—	—
LT215/85R16D	2315	2105	XYK	YYK	YYK	YYL	YYL	ZYK ZYL ZYK
LT215/85R16D	—	—	—	—	—	YYL	YYL	ZYK ZYL ZYK
LT235/85R16D	2623	—	XYM	YYM	—	—	—	ZYM
LT235/85R16D	2623	—	XYM	—	—	—	—	—
LT235/85R16E	3042	—	—	YYN	—	—	—	ZYN
LT235/85R16E	3042	—	XYN	YYN	—	—	—	ZYN
*8-19.5D	2800	2460	XSF	—	YSF	—	—	ZSF ZSE ZSF
	—	—	—	—	—	—	YSE	ZSE ZSF
	—	—	—	—	—	—	YSE	ZSE ZSF
<b>TUBE-TYPE With 7900-lb Rear Axle</b>								
7.50-16C	2060	1815	XPB	—	YPB	—	—	ZPB
7.50-16C	2060	—	XPB	—	—	—	—	—
7.50-16D	2440	2140	—	YPF	YPF	YPG	YPG	ZPF ZPG ZPF
7.50-16D	—	—	—	—	—	YPG	YPG	ZPF ZPG ZPF
7.50-16E	2780	—	—	YPK	—	—	—	ZPK
7.50-16D	2440	2140	XPF	YPF	YPF	YPG	YPG	ZPF ZPC ZPF
7.50-16D	—	—	—	—	—	YPG	YPG	ZPF ZPF
7.50-16C	—	1815	—	—	YPB	—	—	ZPF
7.50-16D	2440	—	XPF	—	—	—	—	—
7.50-16E	2780	—	—	YPK	—	—	—	ZPK
7.50-16D Polyester	2440	2140	XPE	YPE	YPE	—	—	ZPE
7.50-16E	2780	—	XPK	YPK	—	—	—	ZPK
<b>TUBELESS With 11,000-lb Rear Axle</b>								
*8-19.5D	2800	2460	XSF	—	YSF	—	—	ZSF ZSE ZSF
	—	—	—	—	—	—	YSE	ZSE ZSF
‡8-19.5E	—	2780	—	—	YSG	—	—	ZSG
‡8-19.5E	3170	2780	XSG	—	YSG	—	—	ZSG

\*Requires GQ1 axle with L25 engine.

‡Requires HA3 5.29 rear axle ratio.

## **STEP-VAN/VALUE VAN**

### **THE FOLLOWING EQUIPMENT IS STANDARD ON DIESEL ENGINE MODELS (ALSO SEE STANDARD SPECIFICATIONS PAGES)**

- Low Coolant Sensor
- Poly-wrapped Paper Element Air Cleaner
- Auxiliary Engine Oil Cooler (in addition to cooler in radiator tank) provided with 5.13 or 5.29 ratio rear axle on P30/3500 models only
- Power Steering
- Engine Block Heater
- Water/fuel separator unit which incorporates a water sensor and sending unit, a fuel filter, a fuel heater and water drain capability
- Hydraulic Power-assisted Brakes
- K81 66-amp Generator
- Engine Oil Cooler (located in radiator tank)
- Dual 550 Cold Cranking Amp/115 min. Reserve Capacity Batteries
- HD Radiator
- Dual Exhaust System
- Additional Insulation (on Van models only):
  - Special engine housing cover with triple layer inner insulator and single piece rubber floor seal
  - Fiberglass dash mat
  - Black rubber mats on dash and floor panel
  - Perforated driver compartment headliner with fiberglass backing
  - Fiberglass front quarter panel insulation
  - Additional body sealing measures
- Warning Lights: Glow Plugs, Water-in-fuel (or fuel filter), and Low Coolant
- Diesel Engine Identification:
  - Nameplate on rear door
  - “Diesel Fuel Only” filler cap and label

# STEP-VAN/VALUE VAN OR F.C. CHASSIS (6800-lb - 10,000-lb GVW)

For P3 Series equipped with 11,000-lb rear axle or B3D see pages entitled:

\*P3 SERIES STEP-VAN/VALUE VAN AND F.C. CHASSIS (12,000-lb-14,000-lb GVW) or P3 Series F.C. Chassis with B3D School Bus Chassis  
(11,500-lb-14,500-lb GVW)\*

## 1984 VEHICLES WITH STANDARD EQUIPMENT

Prices shown are effective with vehicles produced on and after February 13, 1984

Description	Model Number	Body Code	Wheel Base	Factory D&H(a)	List Price	Mfr's Suggested Retail Price*	Group Number
<b>◆ 6-Cylinder 4.8 Liter (292 Cu. In.) 1 BBL L6 Gasoline Engine—Engine Ordering Code L25</b>							
<b>P20/P2500 Series</b>							
** Step-Van/Value Van Steel (10 1/2 ft) ...	CP/TP20842	E32	125"	.20	12698.00	12698.20	15
F.C. Chassis ...	CP/TP20842	ZW9	125"	.20	7479.00	7479.20	14
** Step-Van/Value Van Aluminum (10 1/2 ft) ...	CP/TP20842	E33	125"	.20	14570.00	14570.20	15
** Step-Van/Value Van Steel (12 1/2 ft) ...	CP/TP21042	E32	133"	.20	12966.00	12966.20	15
F.C. Chassis ...	CP/TP21042	ZW9	133"	.20	7542.00	7542.20	14
** Step-Van/Value Van Aluminum (12 1/2 ft) ...	CP/TP21042	E33	133"	.20	15073.00	15073.20	15
<b>P30/P3500 Series</b>							
** Step-Van/Value Van Steel (10 1/2 ft) ...	CP/TP30842	E32	125"	.30	12777.00	12777.30	15
F.C. Chassis ...	CP/TP30842	ZW9	125"	.30	7558.00	7558.30	14
** Step-Van/Value Van Aluminum (10 1/2 ft) ...	CP/TP30842	E33	125"	.30	14649.00	14649.30	15
** Step-Van/Value Van Steel (12 1/2 ft) ...	CP/TP31042	E32	133"	.30	13046.00	13046.30	15
F.C. Chassis ...	CP/TP31042	ZW9	133"	.30	7622.00	7622.30	14
** Step-Van/Value Van Aluminum (12 1/2 ft) ...	CP/TP31042	E33	133"	.30	15153.00	15153.30	15
** Step-Van/Value Van Steel (14 1/2 ft) ...	CP/TP31442	E32	157"	.30	13288.00	13288.30	15
F.C. Chassis ...	CP/TP31442	ZW9	157"	.30	7686.00	7686.30	14
** Step-Van/Value Van Aluminum (14 1/2 ft) ...	CP/TP31442	E33	157"	.30	15672.00	15672.30	15
F.C. Chassis ...	CP/TP31842	ZW9	178"	.30	9055.00	9055.30	14
** Step-Van/Value Van Aluminum (18 ft) ...	CP/TP31842	E33	178"	.30	18004.00	18004.30	15

★ Manufacturer's Suggested Retail Prices do not include applicable destination charges, state and local taxes, license fees, optional equipment or accessories or special items or services.

◆ Refer to Dealer Order Guide for California Requirements.

\*\* Van models will be shipped to Union City Body Co. where all body work will be done. These units will be serviced and conditioned for highway travel after body is installed.

**MODELS CONTINUED ON FOLLOWING PAGE**

(a) D & H Charges on vehicle and optional equipment include reimbursement to ordering Division for any tax that it has paid, incurred or agreed to pay thereon.

# STEP-VAN/VALUE VAN OR F.C. CHASSIS

## 1984 VEHICLES WITH STANDARD EQUIPMENT

Prices shown are effective with vehicles produced on and after February 13, 1984

Description	Model Number	Body Code	Wheel Base	Factory D&H(a)	List Price	Mfr's Suggested Retail Price★	Group Number
<b>◆ 8-Cylinder 6.2 Liter (379 Cu. In.) H.D Diesel Engine-Engine Ordering Code LL4</b>							
<b>P20/P2500 Series</b>							
** Step-Van/Value Van Steel (10 1/2 ft) ...	CP/TP20842	E32 & B3J	125"	.30	15090.00	15090.30	15
F.C. Chassis .....	CP/TP20842	ZW9 & B3J	125"	.20	9635.00	9635.20	14
** Step-Van/Value Van Aluminum (10 1/2 ft) ...	CP/TP20842	E33 & B3J	125"	.20	16912.00	16912.20	15
** Step-Van/Value Van Steel (12 1/2 ft) ...	CP/TP21042	E32 & B3J	133"	.30	15356.00	15356.30	15
F.C. Chassis .....	CP/TP21042	ZW9 & B3J	133"	.20	9697.00	9697.20	14
** Step-Van/Value Van Aluminum (12 1/2 ft) ...	CP/TP21042	E33 & B3J	133"	.20	17410.00	17410.20	15
<b>P30/P3500 Series</b>							
** Step-Van/Value Van Steel (10 1/2 ft) ...	CP/TP30842	E32 & B3J	125"	.30	15136.00	15136.30	15
F.C. Chassis .....	CP/TP30842	ZW9 & B3J	125"	.30	9713.00	9713.30	14
** Step-Van/Value Van Aluminum (10 1/2 ft) ...	CP/TP30842	E33 & B3J	125"	.30	16990.00	16990.30	15
** Step-Van/Value Van Steel (12 1/2 ft) ...	CP/TP31042	E32 & B3J	133"	.30	15403.00	15403.30	15
F.C. Chassis .....	CP/TP31042	ZW9 & B3J	133"	.30	9776.00	9776.30	14
** Step-Van/Value Van Aluminum (12 1/2 ft) ...	CP/TP31042	E33 & B3J	133"	.30	17489.00	17489.30	15
** Step-Van/Value Van Steel (14 1/2 ft) ...	CP/TP31442	E32 & B3J	157"	.30	15642.00	15642.30	15
F.C. Chassis .....	CP/TP31442	ZW9 & B3J	157"	.30	9840.00	9840.30	14
** Step-Van/Value Van Aluminum (14 1/2 ft) ...	CP/TP31442	E33 & B3J	157"	.30	18003.00	18003.30	15
** Step-Van/Value Van Aluminum (18 ft) ...	CP/TP31842	E33 & B3J	178"	.30	11042.00	11042.30	14
				.30	20159.00	20159.30	15

★ Manufacturer's Suggested Retail Prices do not include applicable destination charges, state and local taxes, license fees, optional equipment or accessories or special items or services.

◆ Refer to Dealer Order Guide for California Requirements.

\*\* Van models will be shipped to Union City Body Co. where all body work will be done. These units will be serviced and conditioned for highway travel after body is installed.

## OPTIONS AND ACCESSORIES WHEN INSTALLED BY GENERAL MOTORS

Prices shown are effective with vehicles produced on and after February 13, 1984

Description	Option Number	Factory D&H(a)	List Price	Mfr's Suggested Retail Price◇
<b>Emission Systems: Dealer Note - One of the following emission options must be specified. (See Power Teams Chart for availability and complete specifications).</b>				
<b>California Emission Requirements.</b> P3 Series only. Includes all testing, equipment and/or certification necessary for registration in the State of California. Available only when 9000-lb GVWR or greater is achieved				
Without B3J Diesel Equipment .....	YF5	N.A.	235.00	235.00
With B3J Diesel Equipment .....	YF5	N.A.	235.00	235.00
<b>High Altitude Emission Equipment.</b> Available only when B3J Diesel Equipment is specified. Not available when YF5 California Emissions or NA5 Standard Emission Requirements is specified .....				
	NA6	NO ADDITIONAL CHARGE		
<b>Standard Emission Equipment.</b> Not available when NA6 High Altitude or YF5 California Emission Requirements are specified. ....				
	NA5	NO ADDITIONAL CHARGE		

(a) D & H Charges on vehicle and optional equipment include reimbursement to ordering Division for any tax that it has paid, incurred or agreed to pay thereon.

◇ State and local taxes not included.

# STEP-VAN/VALUE VAN OR F.C. CHASSIS

## OPTIONS AND ACCESSORIES WHEN INSTALLED BY GENERAL MOTORS

Prices shown are effective with vehicles produced on and after February 13, 1984

Description	Option Number	Factory D&H(a)	List Price	Mfr's Suggested Retail Price◇
<b>Engines:</b> (See Power Teams Chart for availability and complete specifications)				
Gasoline.				
4.8 Liter (292 Cu. In.) 1 BBL L6 .....	L25	NO ADDITIONAL CHARGE		
5.7 Liter (350 Cu. In.) 4 BBL V8 .....	LT9	N.A.	500.00	500.00
Diesel.				
6.2 Liter (379 Cu. In.) H.D. V8 Diesel. Available only when B3J Diesel Equipment is specified .....	LL4	NO ADDITIONAL CHARGE		
<b>Transmissions:</b>				
3-Speed Automatic. Includes extra cooling.				
P2 Series only .....	MX1	N.A.	492.00	492.00
P3 Series only .....	MX1	N.A.	492.00	492.00
4-Speed Manual .....	MM4	NO ADDITIONAL CHARGE		
<b>Axles, Rear:</b> (See Power Teams Chart for option number selection, availability and complete specifications)				
Optional Ratio .....	...	N.A.	36.00	36.00
Locking Differential .....	G80	N.A.	230.00	230.00
Capacity 11,000-lb. For P3 Series equipped with 11,000-lb rear axle, see pages entitled: "P3 Series Step-Van/Value Van or F.C. Chassis (11,500-lb-14,500-lb GVW), or P3 Series F.C. Chassis with B3D School Bus Chassis (11,500-lb-14,500-lb GVW)"				
<b>Tires:</b> (See Tire Charts for Tire Availability)				
All rim sizes are 6.50" on P2 Series and P3 Series without R05 Dual Rear Wheels.				
All rim sizes are 6.00" on P3 Series with R05 Dual Rear Wheels.				
<b>Dealer Note:</b> When dual rear tires are specified, R05 Dual Rear Wheels will be applied to the order.				
THIS EQUIPMENT IS NOT PRICED IN THE TIRE OPTION AND WILL BE REFLECTED ON THE INVOICE SEPARATELY.				
For complete specifications and ordering information, see "OTHER OPTIONS" Section.				
TUBELESS				
LT215/85R16-C Steel Belted Radial Ply Blackwall				
(Maximum Capacity Front and Single Rear 1940-lbs)				
(Maximum Capacity Dual Rear 1764-lbs)				
Front				
P2 Series (Standard) .....	XYJ	NO ADDITIONAL CHARGE		
P3-Series without R05 Dual Rear Wheels (Standard) ..	XYJ	NO ADDITIONAL CHARGE		
P3 Series with R05 Dual Rear Wheels except P31842 ..	XYJ	N.C.	22.00	22.00
P31842 only (Standard) .....	XYJ	NO ADDITIONAL CHARGE		
Rear				
P2 Series and P31842 only. (Standard) Not available on E32 Steel Body when B3J Diesel Equipment is specified .....	YYJ	NO ADDITIONAL CHARGE		
P3 Series only except P31842 .....	YYJ	N.C.	578.00	578.00
Spare. Available on Step-Van/Value Van only when P14 or P15 Spare Wheel Carrier is specified.				
P2 Series only. Not available on E32 Steel Body when B3J Diesel Equipment is specified .....	ZYJ	.05	283.00	283.05
P3 Series only .....	ZYJ	.05	294.00	294.05

(a) D & H Charges on vehicle and optional equipment include reimbursement to ordering Division for any tax that it has paid, incurred or agreed to pay thereon.  
 ◇ State and local taxes not included.

# STEP-VAN/VALUE VAN OR F.C. CHASSIS

## OPTIONS AND ACCESSORIES WHEN INSTALLED BY GENERAL MOTORS

Prices shown are effective with vehicles produced on and after February 13, 1984

Description	Option Number	Factory D&H(a)	List Price	Mfr's Suggested Retail Price ◇
<b>Tires: (Continued)</b>				
<i>LT235 /85R16-E Steel Belted Radial Ply Blackwall</i>				
(Maximum Capacity 3042-lbs)				
P3 Series only.				
Front .....	XYN	1.94	116.00	117.94
Rear .....	YYN	1.94	84.00	85.94
Spare. Available on Step-Van/Value Van only when P14 or P15 Spare Wheel Carrier is specified .....				
	ZYN	1.02	341.00	342.02
<i>LT215/85R16-D Steel Belted Radial Ply Blackwall</i>				
(Maximum Capacity Front and Single Rear 2315-lbs)				
(Maximum Capacity Dual Rear 2105-lbs)				
Front				
P2 Series .....	XYK	.10	32.00	32.10
P3 Series without R05 Dual Rear Wheels or P31842 .....	XYK	.10	32.00	32.10
P3 Series with R05 Dual Rear Wheels .....	XYK	.10	54.00	54.10
P31842 only .....	XYK	.10	32.00	32.10
Rear				
P2 Series				
With ZW9 or E33 Aluminum Body .....	YYK	.10	32.00	32.10
With E32 Steel Body				
Without B3J Diesel Equipment .....	YYK	.10	32.00	32.10
With B3J diesel Equipment .....	YYK	NO ADDITIONAL CHARGE		
P3 Series.				
With single rear wheels (Standard) .....	YYK	NO ADDITIONAL CHARGE		
With R05 Dual Rear Wheels except P31842 .....	YYK	.30	642.00	642.30
P31842 .....	YYK	.20	64.00	64.20
Spare. Available on Step-Van/Value Van only when P14 or P15 Spare Wheel Carrier is specified.				
P2-3 Series without R05 Dual Rear Wheels or P31842 .....	ZYK	.10	299.00	299.10
P3 Series with R05 Dual Rear Wheels or P31842 .....	ZYK	.10	310.00	310.10
<i>LT215/85R16-D On-Off Road Steel Belted Radial Ply Blackwall</i>				
Rear				
P2 Series only				
With ZW9 or E33 Aluminum Body .....	YYL	.46	86.00	86.46
With E32 Steel Body				
Without B3J diesel Equipment .....	YYL	.46	86.00	86.46
With B3J Diesel Equipment .....	YYL	.36	54.00	54.36
P3 Series without R05 Dual Rear Wheels .....	YYL	.36	54.00	54.36
P3 Series with R05 Dual Rear Wheels except P31842 .....	YYL	.92	750.00	750.92
P31842 .....	YYL	.92	172.00	172.92
Spare. Available on Step-Van/Value Van only when P14 or P15 Spare Wheel Carrier is specified.				
P2-3 Series without R05 Dual Rear Wheels or P31842 .....	ZYL	.28	326.00	326.28
P3 Series with R05 Dual Rear Wheels or P31842 .....	ZYL	.28	337.00	337.28

(a) D & H Charges on vehicle and optional equipment include reimbursement to ordering Division for any tax that it has paid, incurred or agreed to pay thereon.  
 ◇ State and local taxes not included.

# STEP-VAN/VALUE VAN OR F.C. CHASSIS

## OPTIONS AND ACCESSORIES WHEN INSTALLED BY GENERAL MOTORS

Prices shown are effective with vehicles produced on and after February 13, 1984

Description	Option Number	Factory D&H(a)	List Price	Mfr's Suggested Retail Price◇
<b>Tires: (Continued)</b>				
<i>LT235 /85R16-D Steel Belted Radial Ply Blackwall</i>				
(Maximum Capacity 2623-lbs)				
Front				
Rear	XYM	1.80	84.00	85.80
P2 Series with ZW9 Chassis or E33 Aluminum Body	YYM	1.80	84.00	85.80
P2 Series with E32 Steel Body				
Without B3J Diesel Equipment	YYM	1.80	84.00	85.80
With Diesel Equipment	YYM	1.70	52.00	53.70
P3 Series	YYM	1.70	52.00	53.70
Spare. Available on Step-Van/Value Van only when P14 or P15 Spare Wheel Carrier is specified.	ZYM	.95	325.00	325.95
<i>8-19.5/D Highway Nylon Blackwall</i>				
(Maximum Capacity, Front 2800-lbs) (Dual Rear 2460-lbs)				
With L25 4.8 Liter Engine available only when GQ1 Axle is specified. With LT9 5.7 Liter Engine or B3J Diesel Equipment not available with 4.10 rear axle ratio.				
Front				
All except P31842	XSF	2.08	(-62.00)	(-59.92)
P31842 only	XSF	2.08	(-84.00)	(-81.92)
Rear				
All except P31842	YSF	4.16	410.00	414.16
P31842 only	YSF	4.16	(-168.00)	(-163.84)
Spare. Available on Step-Van/Value Van only when P14 or P15 Spare Wheel Carrier is specified	ZSF	1.09	252.00	253.09
<i>8-19.5/D On-Off Road Nylon Blackwall</i>				
(Maximum Capacity, Dual Rear 2460-lbs)				
Rear				
All except P31842	YSE	7.52	526.00	533.52
P31842 only	YSE	7.52	(-52.00)	(-44.48)
Spare. Available on Step-Van/Value Van only when P14 or P15 Spare Wheel Carrier is specified.	ZSE	1.93	281.00	282.93
<b>TUBE-TYPE</b>				
<i>7.50-16/C Highway Nylon Ply Blackwall</i>				
(Maximum Capacity Front and Single Rear 2060-lbs)				
(Maximum Capacity Dual Rear 1815 lbs)				
Front				
P2-3 Series without R05 Dual Rear Wheels or P31842	XPB	(-.10)	(-222.00)	(-222.10)
P3 Series with R05 Dual Rear Wheels	XPB	(-.10)	(-200.00)	(-200.10)
Rear				
P2 Series. Not available on E32 Steel Step-Van when B3J Diesel Equipment is specified	YPB	(-.10)	(-222.00)	(-222.10)
P3 Series with R05 Dual Rear Wheels except P31842	YPB	(-.20)	134.00	133.80
P31842	YPB	(-.20)	(-444.00)	(-444.20)
Spare. Available on Step-Van/Value Van only when P14 or P15 Spare Wheel Carrier is specified.				
P2 Series only	ZPB	N.C.	172.00	172.00
P3 Series with Dual Rear Wheels or P31842	ZPB	N.C.	183.00	183.00
<i>7.50-16/D Highway Nylon Ply Blackwall</i>				
(Maximum Capacity Front and Single Rear 2440-lbs)				
(Maximum Capacity Dual Rear 2140-lbs)				
Front				
P2-3 Series without R05 Dual Rear Wheels or P31842	XPF	(-.10)	(-190.00)	(-190.10)
P3 Series with R05 Dual Rear Wheels	XPF	(-.10)	(-168.00)	(-168.10)
Rear				
P2 Series only				
With ZW9 Chassis or E33 Aluminum Body	YPF	(-.10)	(-190.00)	(-190.10)
With E32 Steel Body				
Without B3J Diesel Equipment	YPF	(-.10)	(-190.00)	(-190.10)
With B3J Diesel Equipment	YPF	(-.20)	(-222.00)	(-222.20)
P3 Series without R05 Dual Rear Wheels	YPF	(-.20)	(-222.00)	(-222.20)
P3 Series with R05 Dual Rear Wheels except P31842	YPF	(-.20)	198.00	197.80
P31842 only	YPF	(-.20)	(-380.00)	(-380.20)
Spare. Available on Step-Van/Value Van only when P14 or P15 Spare Wheel Carrier is specified.				
P2-3 Series without R05 Dual Rear Wheels	ZPF	N.C.	188.00	188.00
P3 Series with R05 Dual Rear Wheels or P31842	ZPF	N.C.	199.00	199.00

(a) D & H Charges on vehicle and optional equipment include reimbursement to ordering Division for any tax that it has paid, incurred or agreed to pay thereon.  
 ◇ State and local taxes not included.



# STEP-VAN/VALUE VAN OR F.C. CHASSIS

## OPTIONS AND ACCESSORIES WHEN INSTALLED BY GENERAL MOTORS

Prices shown are effective with vehicles produced on and after February 13, 1984

Description	Option Number	Factory D&H(a)	List Price	Mfr's Suggested Retail Price ◊
<b>Tires: (Continued)</b>				
<i>7.50-16/D On-Off Road Nylon Ply Blackwall</i>				
(Maximum Capacity Front and Single Rear 2440-lbs)				
(Maximum Capacity Dual Rear 2140-lbs)				
Rear				
P2 Series only				
With ZW9 Chassis or E33 Aluminum Body	YPG	(-.02)	(-132.00)	(-132.02)
With E32 Steel Body				
Without B3J Diesel Equipment	YPG	(-.02)	(-132.00)	(-132.02)
With B3J Diesel Equipment	YPG	(-.12)	(-164.00)	(-164.12)
P3 Series without R05 Dual Rear Wheels	YPG	(-.12)	(-164.00)	(-164.12)
P3 Series with R05 Dual Rear Wheels except P31842	YPG	(-.04)	314.00	313.96
P31842 only	YPG	(-.04)	(-264.00)	(-264.04)
Spare. Available on Step-Van/Value Van only when P14 or P15 Spare Wheel Carrier is specified.				
P2-3 Series without R05 Dual Rear Wheels	ZPG	.04	217.00	217.04
P3 Series with R05 Dual Rear Wheels or P31842	ZPG	.04	228.00	228.04
<i>7.50-16/D Highway Polyester Ply Blackwall</i>				
(Maximum Capacity Front and Single Rear 2440-lbs)				
(Maximum Capacity Dual Rear 2140-lbs)				
Front				
P3 Series without R05 Dual Rear Wheels or P31842	XPE	(-.10)	(-144.00)	(-144.10)
P3 Series with R05 Dual Rear Wheels	XPE	(-.10)	(-122.00)	(-122.10)
Rear				
P3 Series without R05 Dual Rear Wheels	YPE	(-.20)	(-176.00)	(-176.20)
P3 Series with R05 Dual Rear Wheels except P31842	YPE	(-.20)	290.00	289.80
P31842 only	YPE	(-.20)	(-288.00)	(-288.20)
Spare. Available on Step-Van/Value Van only when P14 or P15 Spare Wheel Carrier is specified.				
P3 Series without R05 Dual Rear Wheels	ZPE	N.C.	211.00	211.00
P3 Series with R05 Dual Rear Wheels or P31842	ZPE	N.C.	222.00	222.00
<i>7.50-16/E Highway Nylon Ply Blackwall</i>				
(Maximum Capacity 2780-lbs)				
Front				
Rear				
P2 Series only				
With ZW9 Chassis or E33 Aluminum Body	YPK	.02	(-158.00)	(-157.98)
With E32 Steel Body				
Without B3J Diesel Equipment	YPK	.02	(-158.00)	(-157.98)
With B3J Diesel Equipment	YPK	(-.08)	(-190.00)	(-190.08)
P3 Series only	YPK	(-.08)	(-190.00)	(-190.08)
Spare. Available on Step-Van/Value Van only when P14 or P15 Spare Wheel Carrier is specified.				
	ZPK	.06	204.00	204.06

### OTHER OPTIONS

**Air Conditioning:** Available only when E32 Steel or E33 Aluminum Body.

Without B3J Diesel Equipment. Also includes K81 Generator and V01 H.D. Radiator is specified

With B3J Diesel Equipment

**Battery:** *Heavy-Duty*. 12-volt. 515 Cold Cranking Amps Delco Freedom. Not available when B3J Diesel Equipment is specified

**Brakes:** *Heavy-Duty Power*. Standard on 178" wheelbase.

**Cooler System:** *Engine Oil*. Available only when LT9 5.7 Liter Engine is specified

Without B3J Diesel Equipment	C60	N.A.	1095.00	1095.00
With B3J Diesel Equipment	C60	N.A.	1074.00	1074.00
Without B3J Diesel Equipment	UA1	N.A.	50.00	50.00
With B3J Diesel Equipment	UA1	N.A.	50.00	50.00
P2 Series only	J55	N.A.	105.00	105.00
P3 Series only	J55	N.A.	105.00	105.00
Without B3J Diesel Equipment	J55	N.A.	218.00	218.00
With B3J Diesel Equipment	J55	N.A.	57.00	57.00
Without B3J Diesel Equipment	KC4	N.A.	116.00	116.00
With B3J Diesel Equipment	KC4	N.A.	116.00	116.00

(a) D & H Charges on vehicle and optional equipment include reimbursement to ordering Division for any tax that it has paid, incurred or agreed to pay thereon.  
 ◊ State and local taxes not included.



# STEP-VAN/VALUE VAN (STEEL) (6800-lb-10,000-lb GVW)

## OPTIONS AND ACCESSORIES WHEN INSTALLED BY UNION CITY BODY COMPANY

Prices shown are effective with vehicles produced on and after February 13, 1984

Description	Option Number	Factory D&H(a)	List Price	Mfr's Suggested Retail Price◇
<b>Dealer Note:</b> When ordering E32 Body, one of the following options must be specified.				
Regular Body Options only .....	YJ1		NO ADDITIONAL CHARGE	
Special Body Options required .....	YJ2		NO ADDITIONAL CHARGE	
<b>Air Vent: Passenger Side.</b> Not available when C60 Air Conditioning is specified .....				
	C56	N.A.	41.00	41.00
<b>Ashtray and Cigarette Lighter:</b> Not available when B3J Diesel Equipment is specified .....				
	DT4	N.A.	36.00	36.00
<b>Bumper: Painted Rear Step with Recessed Lights.</b> Not available on P20842 or P30842 .....				
	V35	N.A.	160.00	160.00
<b>Carrier, Spare Wheel:</b> Inside Mounted.				
Left-hand .....	P14	N.A.	28.00	28.00
Right-hand .....	P15	N.A.	28.00	28.00
<b>Doors, Rear:</b> Specify opening width and door type. (Replacing standard double doors with 38" opening)				
Double Doors. 60" Opening. Includes door glass .....	E76	N.A.	87.00	87.00
Overhead Door. 66" Opening. Includes door glass .....	E46	N.A.	442.00	442.00
Wraparound Double Doors. 74" Opening. Includes door glass .....	E79	N.A.	195.00	195.00
<b>Floor, Cargo:</b> Smooth Steel, 11 Gage .....	E71	N.A.	129.00	129.00
<b>Mirrors:</b>				
Exterior, Wide-Angle. Bright .....	D77	N.A.	46.00	46.00
Interior, Rearview .....	D31	N.A.	36.00	36.00
<b>Paints, Exterior:</b> (See Interior and Exterior Color Selection Chart for ordering information).				
Solid (Chevrolet/GMC option) .....	ZY1		NO ADDITIONAL CHARGE	
Special Applications. Contact Union City Body Company for prices.				
<b>Panel, Sealed:</b> Includes sliding window. Replaces LH side door .....				
	E89	N.A.	69.00	69.00
<b>Partitions: Expanded metal.</b>				
Right-hand Sliding Door .....	AX6	N.A.	388.00	388.00
Center Sliding Door .....	AX7	N.A.	410.00	410.00
Left-hand Side only .....	AX5	N.A.	150.00	150.00
<b>Partition, Plywood:</b> With Sliding Door. Located between driver's seat and load compartment .....				
	AP7	N.A.	252.00	252.00
<b>Radio Equipment:</b>				
AM Radio .....	U63	N.A.	178.00	178.00
AM/FM Radio .....	U69	N.A.	282.00	282.00
<b>Seat Equipment:</b> (Added weight includes passenger weight allowance of 150-lb per seating position. Refer to vehicle and option weight section of Data Book.)				
Front, Auxiliary. Same as standard driver's seat. Not available when AS1 or AX8 Seat is specified. Includes D20 Sunshade .....				
Driver, Deluxe Bucket .....	A57	N.A.	168.00	168.00
Driver, Deluxe Bucket with fixed pedestal .....	AS1	N.A.	114.00	114.00
Passenger, Deluxe Bucket. Available only when AS1 or AX8 Bucket Seat is specified. Includes D20 Sunshade .....	AX8	N.A.	176.00	176.00
	AS2	N.A.	217.00	217.00
<b>Sunshade, Passenger:</b> Included when A57 Auxiliary or AS2 Bucket Seat is specified .....				
	D20	N.A.	43.00	43.00
<b>Ventilator: Roof. Crank Type</b> .....				
	C55	N.A.	102.00	102.00
<b>Wheelhousing: Dual Rear Type.</b> P3 Series only. Available only when R05 Dual Rear Wheels are specified .....				
	E70	N.A.	67.00	67.00
<b>Window, Sliding: Right Front Door.</b> .....				
	AC2	N.A.	89.00	89.00

For special body work not covered by the above options, refer to Union City Body Company Sales Department. Subsequent installation and payment for such special body work will be handled between the body company and the dealer.

(a) D & H Charges on vehicle and optional equipment include reimbursement to ordering Division for any tax that it has paid, incurred or agreed to pay thereon.  
 ◇ State and local taxes not included.

# STEP-VAN/VALUE VAN (ALUMINUM) (6800-lb-10,000-lb GVW)

## OPTIONS AND ACCESSORIES WHEN INSTALLED BY UNION CITY BODY COMPANY

Prices shown are effective with vehicles produced on and after February 13, 1984

Description	Option Number	Factory D&H(a)	List Price	Mfr's Suggested Retail Price ◊
<b>Dealer Note:</b> When ordering E33 Body, one of the following options must be specified.				
Regular Body Options only	YJ1		NO ADDITIONAL CHARGE	
Special Body Options required	YJ2		NO ADDITIONAL CHARGE	
<b>Air Vent:</b> Passenger Side. Not available when C60 Air Conditioning is specified	C56	N.A.	41.00	41.00
<b>Ashtray and Cigarette Lighter:</b> Not available when B3J Diesel Equipment is specified	DT4	N.A.	36.00	36.00
<b>Bumper:</b> Painted. Rear Step with Recessed Lights. Not available on P20842 or P30842.	V35	N.A.	160.00	160.00
<b>Carrier, Spare Wheel:</b> Inside Mounted.				
Left-Hand	P14	N.A.	28.00	28.00
Right-Hand	P15	N.A.	28.00	28.00
<b>Doors, Rear:</b> Specify opening width and door type (Replacing standard double doors with 38" opening).				
<b>Double Doors.</b> 60" Opening with strap hinges. Includes door glass	E76	N.A.	87.00	87.00
<b>Overhead Door.</b> Includes door glass.				
73" Opening	E46	N.A.	442.00	442.00
82" Opening. Available only when E73 9" Body Width Addition is specified	E46	N.A.	442.00	442.00
85" Opening. Available only when E74 13" Body Width Addition is specified	E46	N.A.	442.00	442.00
<b>Wraparound Double Doors.</b> Includes door glass. Not available when E73 9" or E74 13" Body Width Addition is specified.				
74" Opening	E79	N.A.	195.00	195.00
83" Opening. Available only when E73 9" Body Width Addition is specified	E52	N.A.	217.00	217.00
87" Opening. Available only when E74 13" Body Width Addition is specified	E53	N.A.	233.00	233.00
<b>Height Addition, Body:</b> 80" Inside. With 10 1/2 ft body only	E65	N.A.	206.00	206.00
<b>Length Extensions, Body:</b> P31442 only.				
12" Extension	E67	N.A.	336.00	336.00
18" Extension	E72	N.A.	450.00	450.00
<b>Lock, Rear Door:</b> Slam-Type. Not available when E46 Overhead Rear Door is specified	AX9	N.A.	69.00	69.00
<b>Mirrors:</b>				
Exterior, Wide Angle. Bright	D77	N.A.	46.00	46.00
Interior, Rearview	D31	N.A.	36.00	36.00
<b>Paints, Exterior:</b> (See Interior and Exterior Color Selection Chart for ordering information).				
Solid (Chevrolet/GMC option)	ZY1	N.A.	337.00	337.00
Special Applications. Contact Union City Body Company for prices.				
<b>Panel, Sealed:</b> Includes sliding window. Replaces LH side door	E89			NO ADDITIONAL CHARGE
<b>Partitions:</b> Expanded Metal.				
Right-Hand Sliding Door	AX6	N.A.	388.00	388.00
Center Sliding Door	AX7	N.A.	410.00	410.00
Left-Hand side only	AX5	N.A.	150.00	150.00
<b>Partition, Plywood:</b> With Sliding Door. Located between driver's seat and load compartment	AP7	N.A.	252.00	252.00
<b>Radio Equipment:</b>				
AM Radio	U63	N.A.	178.00	178.00
AM/FM Radio	U69	N.A.	282.00	282.00
<b>Seat Equipment:</b> (Added weight includes passenger weight allowance of 150-lb per seating position. Refer to vehicle and option weight section of Data Book.)				
<b>Front Auxiliary.</b> Same as standard driver's seat. Not available when AS1 or AX8 Seat is specified. Includes D20 Sunshade	A57	N.A.	168.00	168.00
Driver, Deluxe Bucket	AS1	N.A.	114.00	114.00
Driver, Deluxe Bucket with fixed pedestal	AX8	N.A.	176.00	176.00
Passenger, Deluxe Bucket. Available only when AS1 or AX8 Bucket Seat is specified. Includes D20 Sunshade	AS2	N.A.	217.00	217.00

(a) D & H Charges on vehicle and optional equipment include reimbursement to ordering Division for any tax that it has paid, incurred or agreed to pay thereon.  
 ◊ State and local taxes not included.



# STEP-VAN/VALUE VAN OR F.C. CHASSIS WITH OPTIONAL 11,000-lb REAR AXLE (12,000-lb or 14,000-lb GVW)

## 1984 VEHICLES WITH STANDARD EQUIPMENT

Prices shown are effective with vehicles produced on and after February 13, 1984

Description	Model Number	Body Code	Wheel Base	Factory D&H(a)	List Price	Mfr's Suggested Retail Price*	Group Number
<b>◆ 6-Cylinder 4.8 Liter (292 Cu. In.) 1 BBL L6 Gasoline Engine-Engine Ordering Code L25</b>							
** Step Van/Value Van Steel (10 1/2 ft) ...	CP/TP30842	E32	125"	.30	12777.00	12777.30	15
F.C. Chassis .....	CP/TP30842	ZW9	125"	.30	7558.00	7558.30	14
** Step-Van/Value Van Aluminum (10 1/2 ft) ...	CP/TP30842	E33	125"	.30	14649.00	14649.30	15
** Step Van/Value Van Steel (12 1/2 ft) ...	CP/TP31042	E32	133"	.30	13046.00	13046.30	15
F.C. Chassis .....	CP/TP31042	ZW9	133"	.30	7622.00	7622.30	14
** Step-Van/Value Van Aluminum (12 1/2 ft) ...	CP/TP31042	E33	133"	.30	15153.00	15153.30	15
** Step Van/Value Van Steel (14 1/2 ft) ...	CP/TP31442	E32	157"	.30	13288.00	13288.30	15
F.C. Chassis .....	CP/TP31442	ZW9	157"	.30	7686.00	7686.30	14
** Step-Van/Value Van Aluminum (14 1/2 ft) ...	CP/TP31442	E33	157"	.30	15672.00	15672.30	15
F.C. Chassis .....	CP/TP31842	ZW9	178"	.30	9055.00	9055.30	14
** Step-Van/Value Van Aluminum (18 ft) ...	CP/TP31842	E33	178"	.30	18004.00	18004.30	15
<b>◆ 8-Cylinder 6.2 Liter (379 Cu. In.) H.D. Diesel V8 Engine-Engine Code LL4</b>							
** Step Van/Value Van Steel (10 1/2 ft) ...	CP/TP30842	E32 & B3J	125"	.30	15136.00	15136.30	15
F.C. Chassis .....	CP/TP30842	ZW9 & B3J	125"	.30	9713.00	9713.30	14
** Step-Van/Value Van Aluminum (10 1/2 ft) ...	CP/TP30842	E33 & B3J	125"	.30	16990.00	16990.30	15
** Step Van/Value Van Steel (12 1/2 ft) ...	CP/TP31042	E32 & B3J	133"	.30	15403.00	15403.30	15
F.C. Chassis .....	CP/TP31042	ZW9 & B3J	133"	.30	9776.00	9776.30	14
** Step-Van/Value Van Aluminum (12 1/2 ft) ...	CP/TP31042	E33 & B3J	133"	.30	17489.00	17489.30	15
** Step Van/Value Van Steel (14 1/2 ft) ...	CP/TP31442	E32 & B3J	157"	.30	15642.00	15642.30	15
F.C. Chassis .....	CP/TP31442	ZW9 & B3J	157"	.30	9840.00	9840.30	14
** Step-Van/Value Van Aluminum (14 1/2 ft) ...	CP/TP31442	E33 & B3J	157"	.30	18003.00	18003.30	15
F.C. Chassis .....	CP/TP31842	ZW9 & B3J	178"	.30	11042.00	11042.30	14
** Step-Van/Value Van Aluminum (18 ft) ...	CP/TP31842	E33 & B3J	178"	.30	20159.00	20159.30	15

★ Manufacturer's Suggested Retail Prices do not include applicable destination charges, state and local taxes, license fees, optional equipment or accessories or special items or services.

◆ Refer to Dealer Order Guide for California Requirements.

\*\* Van models will be shipped to Union City Body Co. where all body work will be done. These units will be serviced and conditioned for highway travel after body is installed.

**Dealer Note:** Be advised that to attain a 12,000-14,000 lb. GVW rating, these models require 11,000-lb. rear axle and V8 engine.

(a) D & H Charges on vehicle and optional equipment include reimbursement to ordering Division for any tax that it has paid, incurred or agreed to pay thereon.

◇ State and local taxes not included.

# STEP-VAN/VALUE VAN OR F.C. CHASSIS WITH OPTIONAL 11,000-lb REAR AXLE

## OPTIONS AND ACCESSORIES WHEN INSTALLED BY GENERAL MOTORS

Prices shown are effective with vehicles produced on and after February 13, 1984

Description	Option Number	Factory D&H(a)	List Price	Mfr's Suggested Retail Price◇
<b>Emission Systems:</b> Dealer Note - One of the following emission options must be specified. (See Power Teams Chart for availability and complete specifications). California Emission Requirements. Includes all testing, equipment and/or certification necessary for registration in the State of California.				
Without B3J Diesel Equipment .....	YF5	N.A.	235.00	235.00
With B3J Diesel Equipment .....	YF5	N.A.	235.00	235.00
<b>High Altitude Emission Equipment.</b> Not available when YF5 California Emission Requirements are specified. Available only when B3J Diesel Equipment is specified .....				
NA6		NO ADDITIONAL CHARGE		
<b>Standard Emission Equipment.</b> Not available when NA6 High Altitude or YF5 California Emission Requirements are specified.....				
NA5		NO ADDITIONAL CHARGE		
<b>Engines:</b> (See Power Teams Chart for availability and complete specifications)				
<b>Gasoline</b>				
5.7 Liter (350 Cu. In.) 4 BBL V8 Gasoline. ....	LT9	N.A.	500.00	500.00
<b>Diesel</b>				
6.2 Liter (379 Cu. In.) H.D. V8 Diesel. Available only when B3J Diesel Equipment is specified .....	LL4		NO ADDITIONAL CHARGE	
<b>Transmissions:</b>				
<b>3-Speed Automatic.</b> Includes extra cooling				
Without HA3 11,000-lb Capacity Rear Axle .....	MX1	N.A.	492.00	492.00
With HA3 11,000-lb Capacity Rear Axle .....	MX1	N.A.	1070.00	1070.00
<b>4-Speed Manual</b> .....				
MM4		NO ADDITIONAL CHARGE		
<b>Axles, Rear:</b> (See Power Teams Chart for option number selection, availability and complete specifications)				
<b>Capacity 11,000-lb. 5.29 Ratio.</b> Not available when L25 4.8 Liter Engine is specified. Available only when R05 Dual Rear Wheels, SF, SE or SG 8-19.5 Tubeless Tires are specified. KC4 Engine Oil Cooler required when LT9 5.7 Liter Engine is specified. MM4 4-Speed Transmission with LT9 5.7 Liter Engine is available only when V01 H.D. Radiator or C60 Air Conditioning is specified. Includes H.D. power 4-wheel disc brakes, 4500-lb front axle, 5000-lb front springs and 5900-lb each main and auxiliary rear springs and propshaft parking brake.				
All except P31842 .....	HA3	N.A.	1866.00	1866.00
P31842 only .....	HA3	N.A.	1648.00	1648.00
<b>Tires:</b> (See Tire Charts for Tire Availability) All rim sizes are 6.00"				
<b>Dealer Note:</b> When dual rear tires are specified, R05 Dual Rear Wheels will be applied to the order. <b>THIS EQUIPMENT IS NOT PRICED IN THE TIRE OPTION AND WILL BE REFLECTED ON THE INVOICE SEPARATELY.</b> For complete specifications and ordering information, see "OTHER OPTIONS" Section.				
<b>TUBELESS</b>				
<b>8-19.5/D Highway Nylon Ply Blackwall</b> (Maximum Capacity, Front 2800-lbs) (Dual Rear 2460-lbs)				
<b>Front</b>				
All except P31842 .....	XSF	2.08	(-62.00)	(-59.92)
P31842 only .....	XSF	2.08	(-84.00)	(-81.92)
<b>Rear</b>				
All except P31842 .....	YSF	4.16	410.00	414.16
P31842 .....	YSF	4.16	(-168.00)	(-163.84)
<b>Spare.</b> Available on Step-Van/Value Van only when P14 or P15 Spare Wheel Carrier is specified. ....				
ZSF		1.09	252.00	253.09
<b>8-19.5/D On-Off Road Nylon Ply Blackwall</b> (Maximum Capacity, Dual Rear 2460-lbs)				
<b>Rear</b>				
All except P31842 .....	YSE	7.52	526.00	533.52
P31842 only .....	YSE	7.52	(-52.00)	(-44.48)
<b>Spare.</b> Available on Step-Van/Value Van only when P14 or P15 Spare Wheel Carrier is specified. ....				
ZSE		1.93	281.00	282.93

(a) D & H Charges on vehicle and optional equipment include reimbursement to ordering Division for any tax that it has paid, incurred or agreed to pay thereon.  
◇ State and local taxes not included.

# STEP-VAN/VALUE VAN OR F.C. CHASSIS WITH OPTIONAL 11,000-lb REAR AXLE

## OPTIONS AND ACCESSORIES WHEN INSTALLED BY GENERAL MOTORS

Prices shown are effective with vehicles produced on and after February 13, 1984

Description	Option Number	Factory D&H(a)	List Price	Mfr's Suggested Retail Price◇
<b>Tires: (Continued)</b>				
<i>8-19.5/E Highway Nylon Ply Blackwall</i>				
<i>(Maximum Capacity, Front 3170-lbs) (Dual Rear 2780-lbs)</i>				
Front				
All except P31842 .....	XSG	2.54	46.00	48.54
P31842 only .....	XSG	2.54	24.00	26.54
Rear				
All except P31842 .....	YSG	5.08	626.00	631.08
P31842 only .....	YSG	5.08	48.00	53.08
Spare. Available on Step-Van/Value Van only when P14 or P15 Spare Wheel Carrier is specified. ....	ZSG	1.32	306.00	307.32

### OTHER OPTIONS

<b>Air Conditioning:</b> Available only when E32 Steel or E33 Aluminum Body is specified. Without B3J Diesel Equipment. Also includes K81 Generator and V01 H.D. Radiator .....	C60	N.A.	1095.00	1095.00
With B3J Diesel Equipment .....	C60	N.A.	1074.00	1074.00
<b>Battery:</b> <i>Heavy-Duty</i> . 12-volt, 515 Cold Cranking Amps Delco Freedom. Not available when B3J Diesel Equipment is specified .....	UA1	N.A.	50.00	50.00
<b>Cooler:</b> <i>Engine Oil</i> . Available only when LT9 5.7 Liter Engine is specified .....	KC4	N.A.	116.00	116.00
<b>Cooling System:</b> <i>Radiator, Heavy-Duty</i> . Not available when B3J Diesel Equipment is specified Included when C60 Air Conditioning is specified. ....	V01	N.A.	51.00	51.00
<b>Generator:</b> <i>66-Amp Delcotron</i> . Included when B3J Diesel Equipment or C60 Air Conditioning is specified .....	K81	N.A.	21.00	21.00
<b>Heater, Engine Block:</b> <i>600 watts, 120 volts</i> . Not available when B3J Diesel Equipment is specified. ....	K05	N.A.	31.00	31.00
<b>Non-School Bus Usage Option:</b> F.C. Chassis only. Not available on 178" wheelbase .....	B3U	NO ADDITIONAL CHARGE		
<b>Wheels, Dual Rear:</b> Standard on CP31842. E32 Steel or E33 Aluminum Body available only when E70 Wheelhousings are specified. Includes dual rear chassis provisions .....	R05	N.A.	72.00	72.00
<b>Wheels, Spare:</b> 19.5" x 6.00" .....	Q34	N.A.	75.00	75.00

(a) D & H Charges on vehicle and optional equipment include reimbursement to ordering Division for any tax that it has paid, incurred or agreed to pay thereon.  
◇ State and local taxes not included.



# STEP-VAN/VALUE VAN (STEEL) WITH OPTIONAL 11,000-lb REAR AXLE (12,000-lb or 14,000-lb GVW)

## OPTIONS AND ACCESSORIES WHEN INSTALLED BY UNION CITY BODY COMPANY

Prices shown are effective with vehicles produced on and after February 13, 1984

Description	Option Number	Factory D&H(a)	List Price	Mfr's Suggested Retail Price◇
<b>Dealer Note:</b> When ordering E32 Body, one of the following options must be specified.				
Regular Body Options only	YJ1		NO ADDITIONAL CHARGE	
Special Body Options required	YJ2		NO ADDITIONAL CHARGE	
<b>Air Vent:</b> Passenger Side. Not available when C60 Air Conditioning is specified				
	C56	N.A.	41.00	41.00
<b>Ashtray and Cigarette Lighter:</b> Not available when B3J Diesel Equipment is specified				
	DT4	N.A.	36.00	36.00
<b>Bumper:</b> Painted. Rear Step with Recessed Lights. Not available on P30842.				
	V35	N.A.	160.00	160.00
<b>Carrier, Spare Wheel:</b> Inside mounted.				
Left-Hand	P14	N.A.	28.00	28.00
Right-Hand	P15	N.A.	28.00	28.00
<b>Doors, Rear:</b> Specify opening width and door type. (Replacing standard double doors with 38" opening). Includes door glass				
Double Doors. 60" opening with strap hinges.	E76	N.A.	87.00	87.00
Overhead Door. 66" Opening.	E46	N.A.	442.00	442.00
Wraparound Double Doors. 74" opening with strap hinges.	E79	N.A.	195.00	195.00
<b>Floor, Cargo:</b> Smooth Steel	E71	N.A.	129.00	129.00
<b>Mirrors:</b>				
Exterior, Wide-Angle. Bright	D77	N.A.	46.00	46.00
Interior, Rearview	D31	N.A.	36.00	36.00
<b>Paints, Exterior:</b> (See Interior and Exterior Color Selection Chart for ordering information)				
Solid (Chevrolet/GMC option)	ZY1		NO ADDITIONAL CHARGE	
Special Applications. Contact Union City Body Company for prices.				
<b>Panel, Sealed:</b> Includes sliding window. Replaces LH side door.				
	E89	N.A.	69.00	69.00
<b>Partitions:</b> Expanded metal.				
Right-Hand Sliding Door	AX6	N.A.	388.00	388.00
Center Sliding Door	AX7	N.A.	410.00	410.00
Left-Hand side only	AX5	N.A.	150.00	150.00
<b>Partition, Plywood:</b> With sliding door. Located between driver's seat and load compartment				
	AP7	N.A.	252.00	252.00
<b>Radio Equipment:</b>				
AM Radio	U63	N.A.	178.00	178.00
AM/FM Radio	U69	N.A.	282.00	282.00
<b>Seat Equipment:</b> (Added weight includes passenger weight allowance of 150-lb per seating position. Refer to vehicle and option weight section of Data Book.)				
Front, Auxiliary. Same as standard driver's seat. Not available when AS1 or AX8 Bucket Seat is specified. Includes D20 Sunshade.				
Driver, Deluxe Bucket	A57	N.A.	168.00	168.00
Driver, Deluxe Bucket with fixed pedestal	AS1	N.A.	114.00	114.00
Passenger, Deluxe Bucket. Available only when AS1 or AX8 Bucket Seat is specified. Includes D20 Sunshade	AX8	N.A.	176.00	176.00
	AS2	N.A.	217.00	217.00
<b>Sunshade, Passenger:</b> Included when A57 Auxiliary Seat or AS2 Bucket Seats is specified				
	D20	N.A.	43.00	43.00
<b>Ventilator:</b> Roof. Crank Type				
	C55	N.A.	102.00	102.00
<b>Wheelhousing:</b> Dual Rear Type. Available only when R05 Dual Rear Wheelc are specified				
	E70	N.A.	67.00	67.00

(a) D & H Charges on vehicle and optional equipment include reimbursement to ordering Division for any tax that it has paid, incurred or agreed to pay thereon.  
◇ State and local taxes not included.



# STEP-VAN/VALUE VAN (ALUMINUM) WITH OPTIONAL 11,000-lb REAR AXLE (12,000-lb or 14,000-lb GVW)

## OPTIONS AND ACCESSORIES WHEN INSTALLED BY UNION CITY BODY COMPANY

Prices shown are effective with vehicles produced on and after February 13, 1984

Description	Option Number	Factory D&H(a)	List Price	Mfr's Suggested Retail Price◇
<b>Dealer Note:</b> When ordering E33 Body, one of the following options must be specified.				
Regular Body Options only .....	YJ1		NO ADDITIONAL CHARGE	
Special Body Options required .....	YJ2		NO ADDITIONAL CHARGE	
<b>Air Vent:</b> Passenger Side. Not available when C60 Air Conditioning is specified .....				
	C56	N.A.	41.00	41.00
<b>Ashtray and Cigarette Lighter:</b> Not available when B3J Diesel Equipment is specified .....				
	DT4	N.A.	36.00	36.00
<b>Bumper:</b> Painted. Rear Step with Recessed Lights. Not available on P30842 .....				
	V35	N.A.	160.00	160.00
<b>Carrier, Spare Wheel:</b> Inside mounted.				
Left-Hand .....	P14	N.A.	28.00	28.00
Right-Hand .....	P15	N.A.	28.00	28.00
<b>Doors, Rear:</b> Specify opening width and door type. (Replacing standard double doors with 38" opening). Includes door glass.				
Double Doors. 60" opening .....	E76	N.A.	87.00	87.00
Overhead Door.				
73" Opening .....	E46	N.A.	442.00	442.00
82" Opening. Available only when E73 9" Body Width Addition is specified .....	E46	N.A.	442.00	442.00
85" Opening. Available only when E74 13" Body Width Addition is specified .....	E46	N.A.	442.00	442.00
Wraparound Double Doors. Includes door glass				
74" Opening .....	E79	N.A.	195.00	195.00
83" Opening. Available only when E73 9" Body Width Addition is specified .....	E52	N.A.	217.00	217.00
87" Opening. Available only when E74 13" Body Width Addition is specified .....	E53	N.A.	233.00	233.00
	E65	N.A.	206.00	206.00
<b>Height Addition, Body 80" Inside .....</b>				
<b>Length Extensions, Body: P31442 only.</b>				
12" Extension .....	E67	N.A.	336.00	336.00
18" Extension .....	E72	N.A.	450.00	450.00
<b>Lock, Rear Door: Slam Type.</b> Not available when E46 Overhead Rear Door is specified .....				
	AX9	N.A.	69.00	69.00
<b>Mirrors:</b>				
Exterior, Wide Angle. Bright .....	D77	N.A.	46.00	46.00
Interior, Rearview .....	D31	N.A.	36.00	36.00
<b>Paints, Exterior:</b> (See Interior and Exterior Color Selection Chart for ordering information).				
Solid (Chevrolet/GMC option) .....	ZY1	N.A.	337.00	337.00
Special Applications. Contact Union City Body Company for prices.				
<b>Panel, Sealed:</b> Includes sliding window. Replaces LH side door .....				
	E89		NO ADDITIONAL CHARGE	
<b>Partitions:</b> Expanded metal.				
Right-Hand Sliding Door .....	AX6	N.A.	388.00	388.00
Center Sliding Door .....	AX7	N.A.	410.00	410.00
Left-Hand side only .....	AX5	N.A.	150.00	150.00
<b>Partition, Plywood:</b> With sliding door. Located between driver's seat and load compartment .....				
	AP7	N.A.	252.00	252.00
<b>Radio Equipment:</b>				
AM Radio .....	U63	N.A.	178.00	178.00
AM/FM Radio .....	U69	N.A.	282.00	282.00

(a) D & H Charges on vehicle and optional equipment include reimbursement to ordering Division for any tax that it has paid, incurred or agreed to pay thereon.  
◇ State and local taxes not included.



# F.C. CHASSIS WITH B3D SCHOOL BUS CHASSIS (11,500-lb - 14,500-lb GVW)

## 1984 VEHICLES WITH STANDARD EQUIPMENT

Prices shown are effective with vehicles produced on and after February 13, 1984

Description	Model Number	Body Code	Wheel Base	Factory D&H(a)	List Price	Mfr's Suggested Retail Price★	Group Number
<b>◆ 6-Cylinder 4.8 Liter (292 Cu. In.) 1 BBL L6 Gasoline Engine-Engine Ordering Code L25</b>							
F.C. Chassis	CP/TP30842	ZW9	125"	N.A.	7558.00	7558.00	14
F.C. Chassis	CP/TP31042	ZW9	133"	N.A.	7822.00	7822.00	14
F.C. Chassis	CP/TP31442	ZW9	157"	N.A.	7686.00	7686.00	14
<b>◆ 8-Cylinder 6.2 Liter (379 Cu. In.) H.D. Diesel V8 Engine-Engine Ordering Code LL4</b>							
F.C. Chassis	CP/TP30842	ZW9 & B3J	125"	N.A.	9713.00	9713.00	14
F.C. Chassis	CP/TP31042	ZW9 & B3J	133"	N.A.	9776.00	9776.00	14
F.C. Chassis	CP/TP31442	ZW9 & B3J	157"	N.A.	9840.00	9840.00	14

- ★ Manufacturer's Suggested Retail Prices do not include applicable destination charges, state and local taxes, license fees, optional equipment or accessories or special items or services.
- ◆ Refer to Dealer Order Guide for California Requirements.

**Dealer Note:** Be advised that to attain a 11,500-14,500 lb. GVW rating, these models require B3D School Bus Chassis.

Please Note: Anyone ordering a vehicle for completion or modification and use as a bus and/or school bus is solely responsible for assuring that such completed vehicle and associated equipment, which might be ordered for the vehicle, comply with all applicable Local, State and Federal Government requirements.

## OPTIONS AND ACCESSORIES WHEN INSTALLED BY GENERAL MOTORS

Prices shown are effective with vehicles produced on and after February 13, 1984

Description	Option Number	Factory D&H(a)	List Price	Mfr's Suggested Retail Price◇
<b>Emission Systems:</b> Dealer Note - One of the following emission options must be specified. (See Power Teams Chart for availability and complete specifications)				
<i>California Emission Requirements.</i> Includes all testing, equipment and/or certification necessary for registration in the State of California.				
Without B3J Diesel Equipment	YF5	N.A.	235.00	235.00
With B3J Diesel Equipment	YF5	N.A.	235.00	235.00
<i>High Altitude Emission Requirements.</i> Available only when B3J Diesel Equipment is specified. Not available when YF5 California Emission or NA5 Standard Emission Requirements is specified				
Standard Emission Equipment. Not available when NA6 High Altitude or YF5 California Emission Requirements are specified	NA6		NO ADDITIONAL CHARGE	
	NA5		NO ADDITIONAL CHARGE	
<b>Engines:</b> (See Power Teams Chart for availability and complete specifications)				
<i>Gasoline.</i>				
4.8 Liter (292 Cu. In.) 1 BBL L6	L25		NO ADDITIONAL CHARGE	
5.7 Liter (350 Cu. In.) 4 BBL V8	LT9	N.A.	500.00	500.00
<i>Diesel</i>				
6.2 liter (379 Cu. In.) H.D. V8 Diesel. Available only when B3J Diesel Equipment is specified	LL4		NO ADDITIONAL CHARGE	
<b>Transmission:</b>				
<i>3-Speed Automatic.</i> Includes extra cooling.				
Without HA3 11,000-lb Capacity Rear Axle	MX1	N.A.	492.00	492.00
With HA3 11,000-lb Capacity Rear Axle	MX1	N.A.	1070.00	1070.00
4-Speed Manual	MM4		NO ADDITIONAL CHARGE	

(a) D & H Charges on vehicle and optional equipment include reimbursement to ordering Division for any tax that it has paid, incurred or agreed to pay thereon.  
◇ State and local taxes not included.

# F.C. CHASSIS WITH B3D SCHOOL BUS CHASSIS

## OPTIONS AND ACCESSORIES WHEN INSTALLED BY GENERAL MOTORS

Prices shown are effective with vehicles produced on and after February 13, 1984

Description	Option Number	Factory D&H(a)	List Price	Mfr's Suggested Retail Price ◇
<b>Axles, Rear:</b> (See Power Teams Chart for option number selection, availability and complete specifications)				
Optional Ratio .....				
Locking Differential. Available only when 4.56 Rear Axle Ratio is specified .....		N.A.	36.00	36.00
Capacity 11,000-lb. 5.29 Ratio. Not available when L25 4.8 Liter Engine is specified. Available only when R05 Dual Rear Wheels and SG 8-19.5 Tubeless Tires are specified. KC4 Engine Oil Cooler required when LT9 5.7 Liter Engine is specified. When MM4 4-Speed Transmission and LT9 5.7 Liter Engine are specified, available only when V01 H.D. Radiator is specified. Includes H.D. power 4-wheel disc brakes, 5000-lb front springs and 5900-lb each main and auxiliary rear springs and prop shaft parking brake .....	G80	N.A.	230.00	230.00
	HA3	N.A.	1866.00	1866.00
<b>Tires:</b> (See Tire Charts for Tire Availability) All rim sizes are 6.00"				
<b>Dealer Note:</b> When dual rear tires are specified, R05 Dual Rear Wheels will be applied to the order. <b>THIS EQUIPMENT IS NOT PRICED IN THE TIRE OPTION AND WILL BE REFLECTED ON THE INVOICE SEPARATELY.</b> For complete specifications and ordering information, see "OTHER OPTIONS" Section.				
<b>TUBE-TYPE</b>				
<b>7.50-16/C Highway Nylon Ply Blackwall</b> (Maximum Capacity Each. Front 2060-lbs)				
Front .....	XPB	N.C.	(-200.00)	(-200.00)
<b>7.50-16/D Highway Nylon Ply Blackwall</b> (Maximum Capacity Each. Front 2440-lbs) (Dual Rear 2140-lbs)				
Front .....	XPF	N.C.	(-168.00)	(-168.00)
Rear .....	YPF	N.C.	198.00	198.00
Spare .....	ZPF	N.C.	199.00	199.00
<b>7.50-16/D Highway Polyester Ply Blackwall</b> (Maximum Capacity Each. Front 2440-lbs)(Dual Rear 2140-lbs)				
Front .....	XPE	N.C.	(-122.00)	(-122.00)
Rear .....	YPE	N.C.	290.00	280.00
Spare .....	ZPE	N.C.	222.00	222.00
<b>7.50-16/D On-Off Road Nylon Ply Blackwall</b> (Maximum Capacity Each. Dual Rear 2140-lbs)				
Rear .....	YPG	N.C.	314.00	314.00
Spare .....	ZPG	N.C.	228.00	228.00
<b>TUBELESS</b>				
<b>8-19.5/D Highway Nylon Ply Blackwall</b> (Maximum Capacity Each. Front 2800-lbs)(Dual Rear 2460-lbs)				
Front .....	XSF	N.C.	(-62.00)	(-62.00)
Rear .....	YSF	N.C.	410.00	410.00
Spare .....	ZSF	N.C.	252.00	252.00
<b>8-19.5/D On-Off Road Nylon Ply Blackwall</b> (Maximum Capacity Each. Dual Rear 2460-lbs)				
Rear .....	YSE	N.C.	526.00	526.00
Spare .....	ZSE	N.C.	281.00	281.00
<b>8-19.5/E Highway Nylon Ply Blackwall</b> (Maximum Capacity Each. Front 3170-lbs)(Dual Rear 2780-lbs)				
Front .....	XSG	N.C.	46.00	46.00
Rear .....	YSG	N.C.	626.00	626.00
Spare .....	ZSG	N.C.	306.00	306.00
<b>LT215/85R16-C Highway Steel Belted Radial Ply Blackwall</b> (Maximum Capacity Each. Front 1940-lbs)				
Front .....	XYJ	N.C.	22.00	22.00
<b>LT215/85R16/D Highway Steel Belted Radial Ply Blackwall</b> (Maximum Capacity Each. Front 2315-lbs)(Dual Rear 2105-lbs)				
Front .....	XYK	N.C.	54.00	54.00
Rear .....	YYK	N.C.	642.00	642.00
Spare .....	ZYK	N.C.	310.00	310.00
<b>LT215/85R16/D On-Off Road Steel Belted Radial Blackwall</b> (Maximum Capacity Each. Dual Rear 2105-lbs)				
Rear .....	YYL	N.C.	750.00	750.00
Spare .....	ZYL	N.C.	337.00	337.00

(a) D & H Charges on vehicle and optional equipment include reimbursement to ordering Division for any tax that it has paid, incurred or agreed to pay thereon.  
◇ State and local taxes not included.

# F.C. CHASSIS WITH B3D SCHOOL BUS CHASSIS

## OPTIONS AND ACCESSORIES WHEN INSTALLED BY GENERAL MOTORS

Prices shown are effective with vehicles produced on and after February 13, 1984

Description	Option Number	Factory D&H(a)	List Price	Mfr's Suggested Retail Price◇
<b>OTHER OPTIONS</b>				
<b>Battery:</b> <i>Heavy-Duty</i> . 12-volt, 515 Cold Cranking Amps Delco Freedom. Not available when B3J Diesel Equipment is specified .....	UA1	N.A.	50.00	50.00
<b>Brake Warning Indicator</b> .....	UJ1	N.A.	40.00	40.00
<b>Brakes:</b> <i>Heavy-Duty Power</i> . Not available when HA3 Rear Axle is specified				
Without B3J Diesel Equipment .....	J55	N.A.	218.00	218.00
With B3J Diesel Equipment .....	J55	N.A.	57.00	57.00
<b>Cooler:</b> <i>Engine Oil</i> . Available only when LT9 5.7 Liter Engine is specified .....	KC4	N.A.	116.00	116.00
<b>Cooling System:</b> <i>Radiator, Heavy-Duty</i> . Not available when B3J Diesel Equipment is specified .....	V01	N.A.	51.00	51.00
<b>Generator:</b> <i>66-Amp Delcotron</i> . Not available when B3M Deluxe School Bus Chassis Equipment is specified. Included when B3J Diesel Equipment is specified .....	K81	N.A.	21.00	21.00
<b>Heater, Engine Block:</b> <i>600 watts, 120 volts</i> . Not available when B3J Diesel Equipment is specified .....	K05	N.A.	31.00	31.00
<b>Preliminary Price Information</b>	B3W	N.A.	N.A.	N.A.
<b>School Bus Chassis Equipment:</b> Available only when HA3 Rear Axle and YSG 8-19.5/E Rear Tires are specified or when G60 Rear Springs and R05 Dual Rear Wheels are specified. Includes 30-gallon shielded rear mounted fuel tank and rear frame alterations .....	B3D	N.A.	249.00	249.00
<b>School Bus Chassis Equipment:</b> <i>Deluxe</i> . Available only when B3D School Bus Equipment is specified. Not available when K81 66-Amp Generator is specified. Includes prop shaft guard, 80-Amp Generator, 100-amp connector for body electrical system, high-note horn (in addition to standard low-note horn) and black painted wheels and front bumper				
Without Diesel Equipment .....	B3M	N.A.	325.00	325.00
With Diesel Equipment .....	B3M	N.A.	260.00	260.00
<b>Springs:</b> <i>Rear, Main and Auxiliary</i> . Capacity 4000-lb each. Not available when HA3 11,000-lb Capacity Rear Axle is specified .....	G60	N.A.	149.00	149.00
<b>Wheels, Dual Rear:</b> Available only when J55 H.D. Brakes or HA3 Rear Axle is specified .....	R05	N.A.	72.00	72.00
<b>Wheel, Spare:</b> <i>19.5" x 6.00"</i> . Available only when SF or SE 8-19.5/D or SG 8-19.5/E Tires are specified .....	Q34	N.A.	75.00	75.00

(a) D & H Charges on vehicle and optional equipment include reimbursement to ordering Division for any tax that it has paid, incurred or agreed to pay thereon.  
 ◇ State and local taxes not included.

# **STEP-VAN/VALUE VAN**

**CAB & BODY FEATURES  
CHASSIS FEATURES  
BODY CONSTRUCTION  
COLOR & TRIM CHARTS**



# STEP-VAN/VALUE VAN

## EXTERIOR FEATURES—STANDARD MODELS

The Standard models include the following items as standard equipment.

### FC CHASSIS

- **Bumper:** Front; painted white
  - **Color:** Chassis and components painted black
  - **Emblem:** Bright Chevrolet emblem/GMC letters (furnished loose in parts box)
  - **Horn:** Single; low note; electric
  - **Hub Caps:** Bright metal with black and ochre trim (single rear wheels only)
  - **Instruments:**
    - Gages: Speedometer, odometer, fuel, voltmeter, oil pressure, and engine temperature
    - Switches: Exterior lights; instrument lights; headlight beam (foot); ignition; direction signal with lane change position; and hazard warning
    - Warning lights: Service-parking brake system; direction/hazard signals, and high beam
- NOTE: Ignition, direction signal, and hazard warning switches are installed; all other gages, switches, and warning lamps are furnished loose in parts box
- **Lights:** Furnished loose in parts box
    - Combination parking/direction/hazard: Two front
    - Combination tail/stop/direction/hazard: Two rear
    - Headlamps: Two; Power Beam
    - License Plate: Two rear
  - **Steering Wheel:** 16" diameter; 2-spoke; black soft vinyl
  - **Wheels:** Painted white

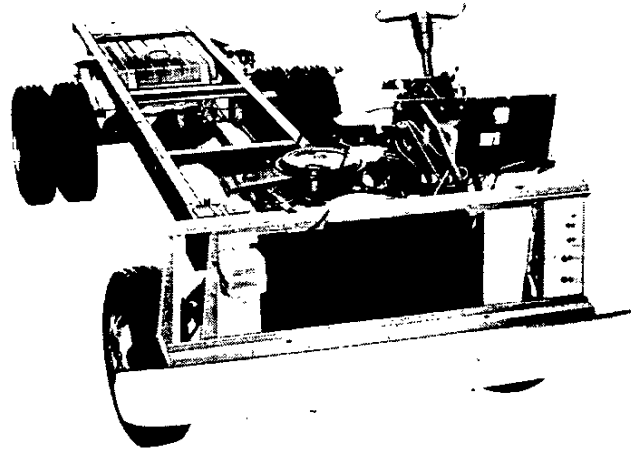

FC CHASSIS

### ALL STEP-VANS/VALUE VANS

- **Bright Appearance Items:**
  - Combination Step-Van/Value Van/Senes Nameplate: Front side panel
- **Bumpers:** Front painted white and rear painted black; top surface of rear step bumper is slip resistant
- **Color:** See Exterior and Interior Color Selection Chart
- **Door Body Protection Bumpers:** Rubber, mounted at rear of body to prevent body damage when opening rear doors
- **Door Opening and Locking Methods:**
  - Front sliding side doors: RH & LH; rotary latch pushbutton release; outside key lock cylinder in RH side door
  - Rear Panel Doors: RH & LH; RH door contains turn handle latch release and outside key lock cylinder; LH door opened by inside release at top of door
- **Front Hood:** Access to battery, radiator, oil filler and dipstick and brake master cylinder
- **Glass:**
  - Two piece windshield; tinted
  - Stationary front quarter glass: Between front windshield pillar and side door opening on each side
  - Sliding side glass in LH side door; stationary glass in RH side door
  - Stationary glass in each rear door panel
- **Horn:** Single; low note; electric
- **Hub Caps:** Bright metal with black and ochre trim (single rear wheels only)
- **Identification:** "CHEVROLET/GMC" on roof over rear doors
- **Instruments:** Same as for FC Chassis, except that all switches, gages and lamps are installed
- **Keys:** Two-key system with separate keys for ignition switch and doors
- **Lights:**
  - Back-up lamps: Two rear
  - Combination parking/direction/hazard: Two front
  - Combination tail/stop/direction/hazard: Two rear
  - Headlamps: Two; Power Beam
  - License Plate: Two rear
  - Side Marker and Reflectors: Two front and two rear
  - Five amber front identification and clearance lamps
  - Five red rear identification and clearance lamps
- **Mirrors:** RH & LH; painted white; adjustable arm with two separate adjustable heads; one with flat glass and one with convex glass
- **Steering Wheel:** 16" diameter; 2 spoke, black soft vinyl
- **Undercoating:** Fully coated under floor, on side panels below floor, and on wheel housings
- **Wheels:** Painted white
- **Windshield Wipers and Washers:** Electric; 2-speed wipers; coordinated washers

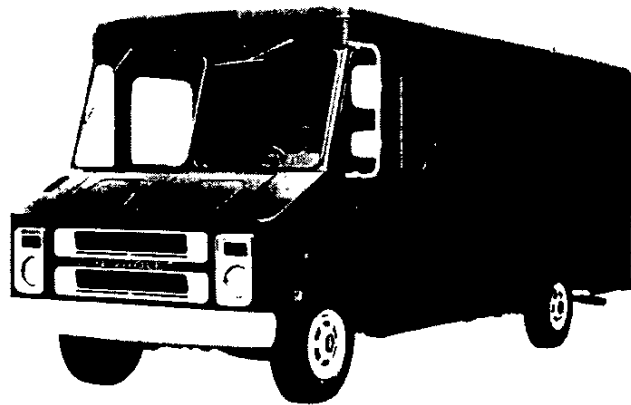

STEEL STEP-VAN/VALUE VAN

Chevrolet model shown (GMC model available)

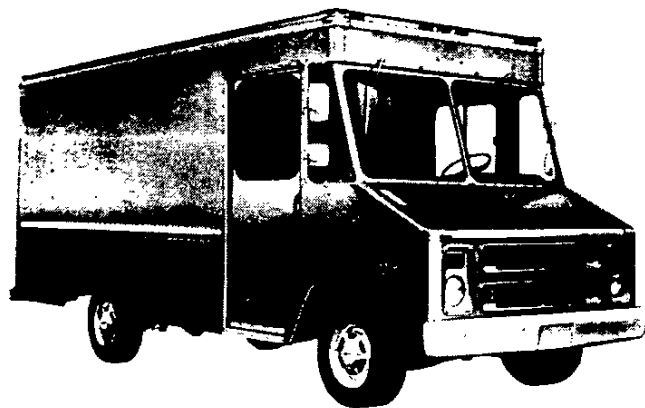

ALUMINUM STEP-VAN/VALUE VAN

GMC model shown (Chevrolet model available)

# STEP-VAN/VALUE VAN

## EXTERIOR FEATURES—STANDARD MODELS

The Standard models include the following items as standard equipment.

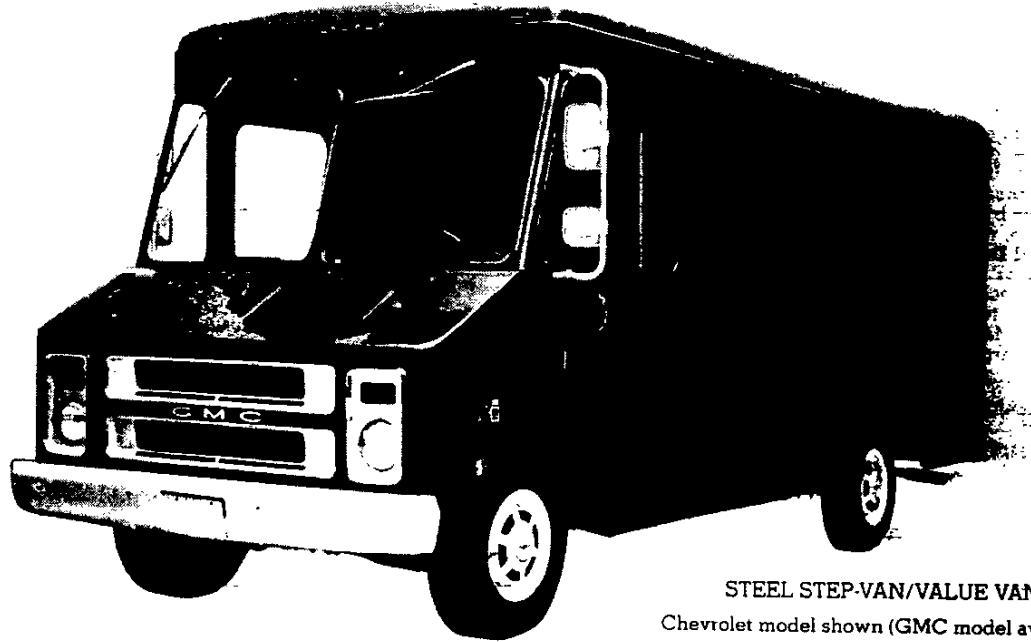

STEEL STEP-VAN/VALUE VAN

Chevrolet model shown (GMC model available)

### STEEL STEP-VANS/VALUE VANS

In addition to those items listed on the preceding page for all Step-Vans/Value Vans, the following items are also standard equipment:

- **Body Panels and Framing:** Painted steel
- **Grille Area:**
  - Grille Panel Openings: Painted white
  - Headlamp—Parking Lamp Bezels: Painted silver
  - Lettering: Painted white or black, depending upon exterior color
  - Moldings: Bright

### ALUMINUM STEP-VANS/VALUE VANS

In addition to those items listed on the preceding page for all Step-Vans/Value Vans, the following items are also standard equipment:

- **Body Panels and Framing:** Aluminum
- **Grille Area:**
  - Grille Panel: Aluminum
  - Grille Panel Openings: Aluminum
  - Headlamp—Parking Lamp Bezels: Bright brushed aluminum
- Moldings: Bright

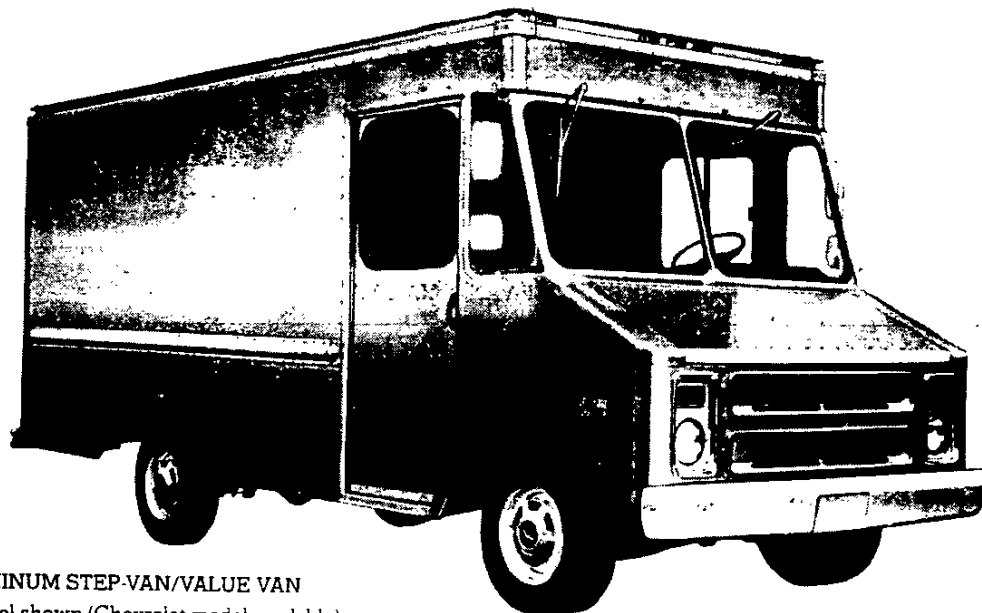

ALUMINUM STEP-VAN/VALUE VAN

GMC model shown (Chevrolet model available)

# STEP-VAN/VALUE VAN

## INTERIOR FEATURES—STANDARD MODELS

The standard models include the following items as standard equipment

### ALL STEP-VANS/VALUE VANS

- **Air Vent:** Integral with Deluxe-air heater and vent with door on driver's side
- **Colors:** Driver area painted with Dark Blue non-reflective paint; area covers entire front-end interior in driver's line of vision. Remainder of interior painted Silver Gray (steel vans only)
- **Door Locks:** Inside lever lock/release
- **Engine Access Cover:** One piece molded fiberglass cover is held down by two rubber T-handles and catches and is entirely removable; with fiberglass insulation and rubber edge seals
- **Heater and Defogger:** Deluxe-air; two speed blower
- **Instruments:**
  - Gages: Speedometer, odometer, fuel, voltmeter, oil pressure, and engine temperature
  - Switches: Main, for control of exterior lights; instrument lights; front and cargo compartment dome lights; wiper-washer; headlight beam (foot); ignition; direction signal with lane change position; hazard warning; and heater fan
- **Warning lights:** Service-parking brake system; direction/hazard signals, and high beam
- **Interior Lights:** Instrument, front and rear compartment dome operated by main light switch
- **Parcel Tray:** Top of engine housing with raised edge
- **Seat:** Individual driver, foam padded, Dark Red grained vinyl; pedestal-mounted, fold-forward type; pedestal lock secures seat in driving position; fully-adjustable: forward, backward, up, or down
- **Seat Belt:** Includes belt holder loops on seat frame; pushbutton release
- **Steering Wheel:** 16" diameter; 2-spoke; black soft vinyl
- **Visor:** Driver's side, 8" x 10" tinted plexiglass, adjustable

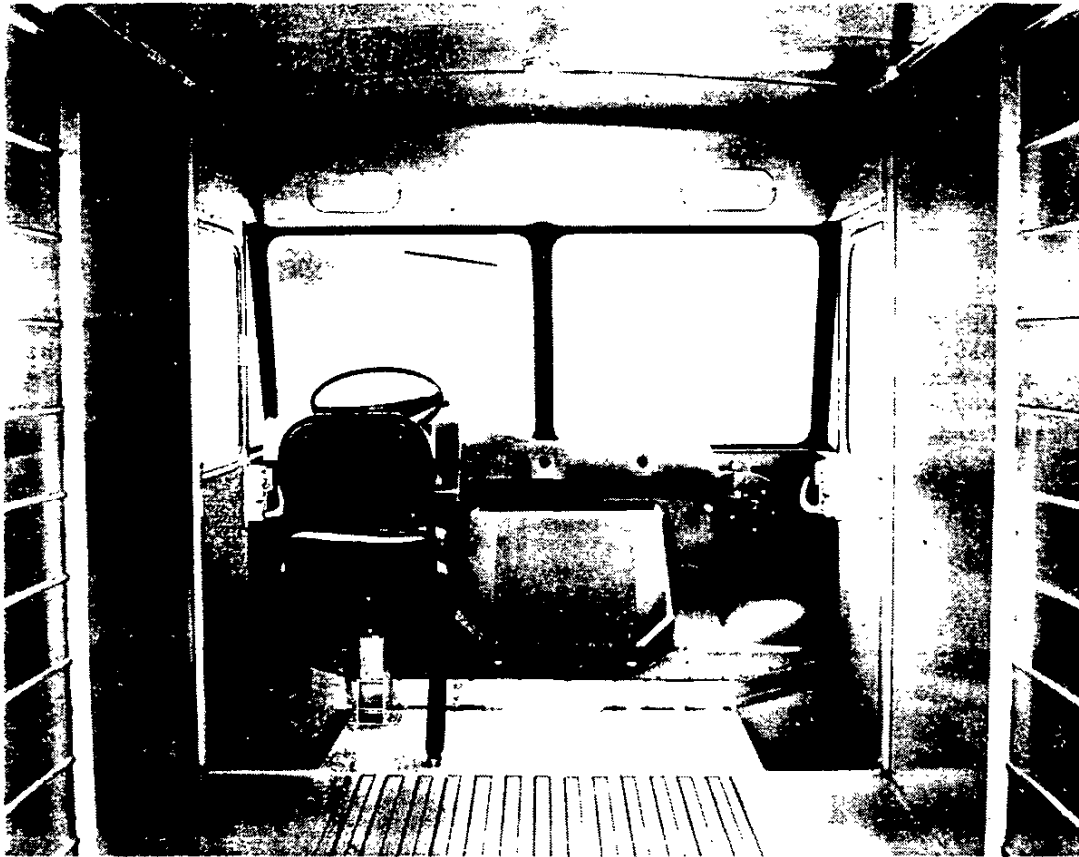

STEEL STEP-VAN/VALUE VAN

### STEEL STEP-VAN/VALUE VAN

In addition to the items listed above for all Step-Vans/Value Vans, the following items are also included

- **Door Seals:** Molded rubber; forward edge of front doors
- **Floor Area:**
  - Driver floor: Smooth steel
  - Floor between seat and load area and stepwells: Steel treadplate
  - Load area: Corrugated 18-gage steel
- **Inner Trim Panels:** Covers inner side walls, rear end, and entire roof area (ribbed steel on sidewalls, smooth on roof)
- **Insulation and Sound Deadening Material:** Between outer and inner panels, the area is lined with 1" fiberglass; engine access cover underside fully insulated with fiberglass

# STEP-VAN/VALUE VAN

## INTERIOR FEATURES—STANDARD MODELS

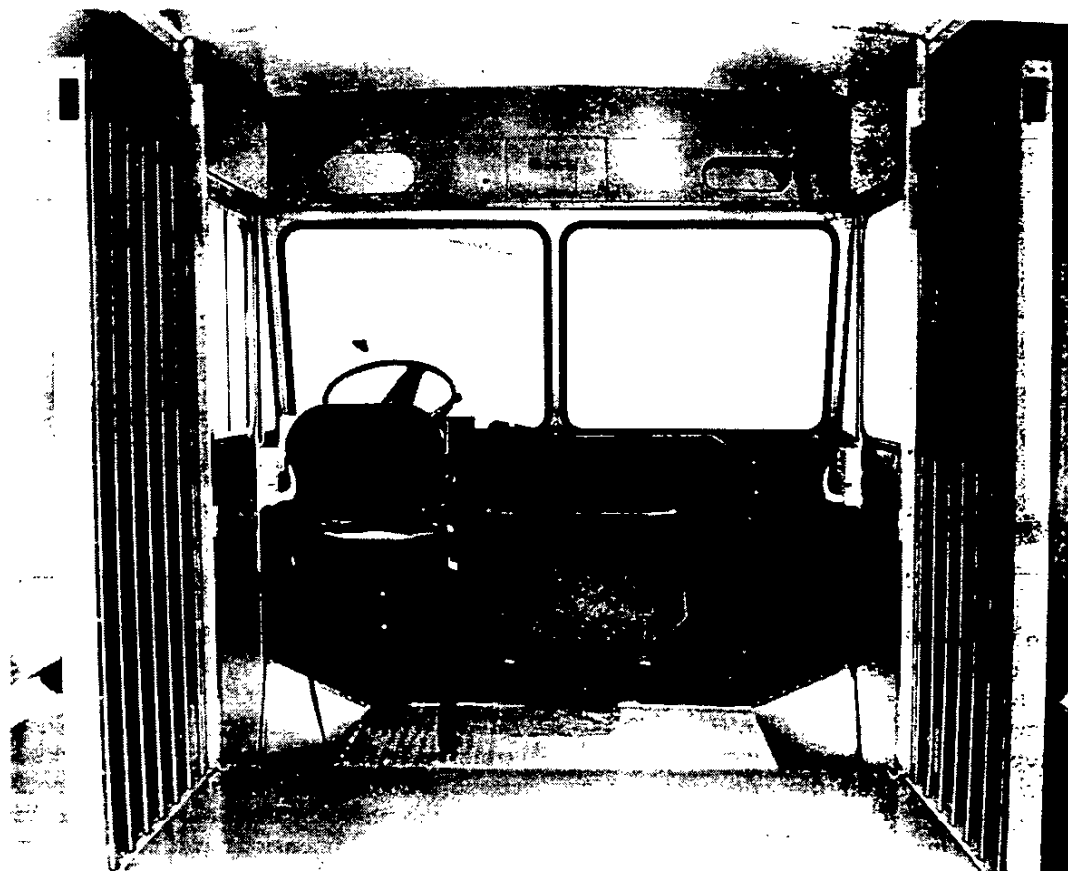

ALUMINUM STEP-VAN/VALUE VAN

### ALUMINUM STEP-VAN/VALUE VAN

In addition to the items listed for all Step-Vans/Value Vans on the preceding page, the following items are also included:

- **Door Seals:** Foam rubber; recessed in the extrusion at the front of the side door opening; compresses against the front edge of the side door when door is closed
- **Floor Area:**
  - Driver area: Smooth steel
  - Load area: Smooth aluminum
  - Floor between seat and load area and stepwells: Aluminum treadplate
- **Inner Roof Trim Panel:** Embossed aluminum; covers entire roof area
- **Insulation and Sound Deadening Material:** Between outer and inner roof panels the area is lined with 1" fiberglass; engine access cover underside fully insulated with fiberglass
- **Side Sliding Door Guide:** Aluminum extrusions; mounted on bottom of door opening; contains polypropylene inserts to guide opening of door; provides weather seal and eliminates door rattles
- **Side Sliding Door Pockets:** Corrugated rigid aluminum; completely encloses door when opened

# STEP-VAN/VALUE VAN

## STEP-VAN/VALUE VAN—STEEL GENERAL FEATURES

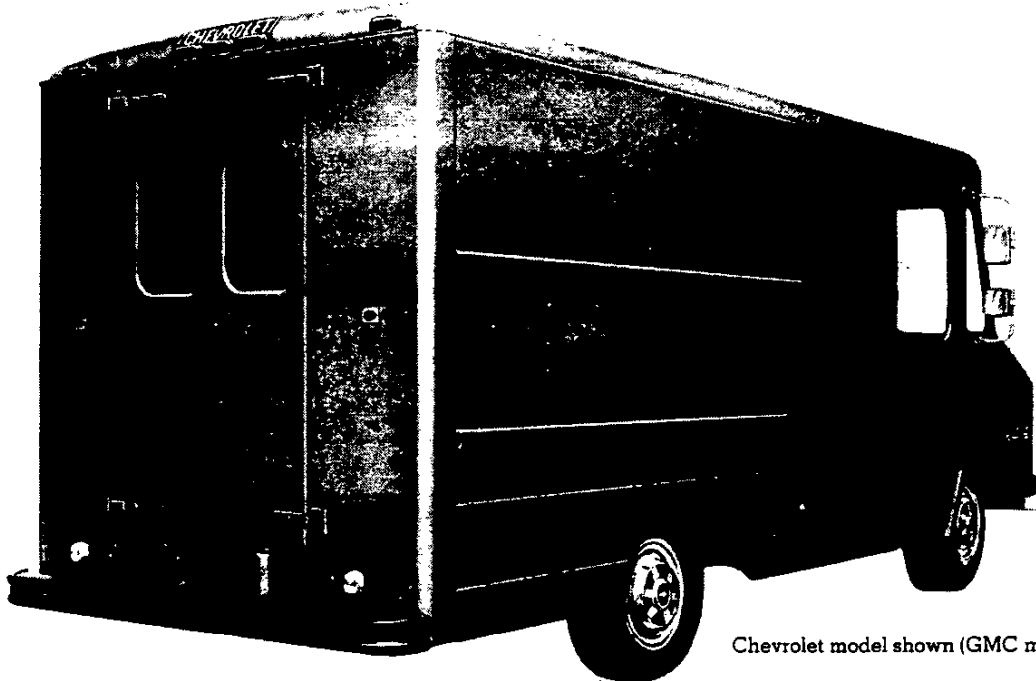

Chevrolet model shown (GMC model available)

Step-Van/Value Van models are available in three standard nominal lengths of ten feet six inches, twelve feet six inches and fourteen feet six inches. The fourteen-foot six inch model is available only in the 30/3500 Series. All Step-Van/Value Van steel bodies feature rugged welded and bolted all-steel construction for maximum strength.

Front and rear side marker lights and roof-mounted identification and clearance lights are provided as stan-

dard equipment, mounted below the roof line for protection. Left- and right-hand dual-head outside rearview mirrors and rear door glass are also standard.

One-piece steel bathtub-type front wheelhousings help to protect the body from corrosion, and thick steel radiator supports help to strengthen overall structural rigidity.

See the chart on the Step-Van/Value Van dimension page for dimensions and cubic capacities of all the bodies.

## SERVICE FEATURES



GMC model shown  
(Chevrolet model available)

The design features a front opening hood for better service access to the engine, battery, radiator, and other chassis items.

*Note: See white tabs Special Equipment for Union City Bodies and Special Equipment Options for a listing of special items.*

## STEP-VAN/VALUE VAN

### STEP-VAN/VALUE VAN—STEEL

#### BODY FEATURES

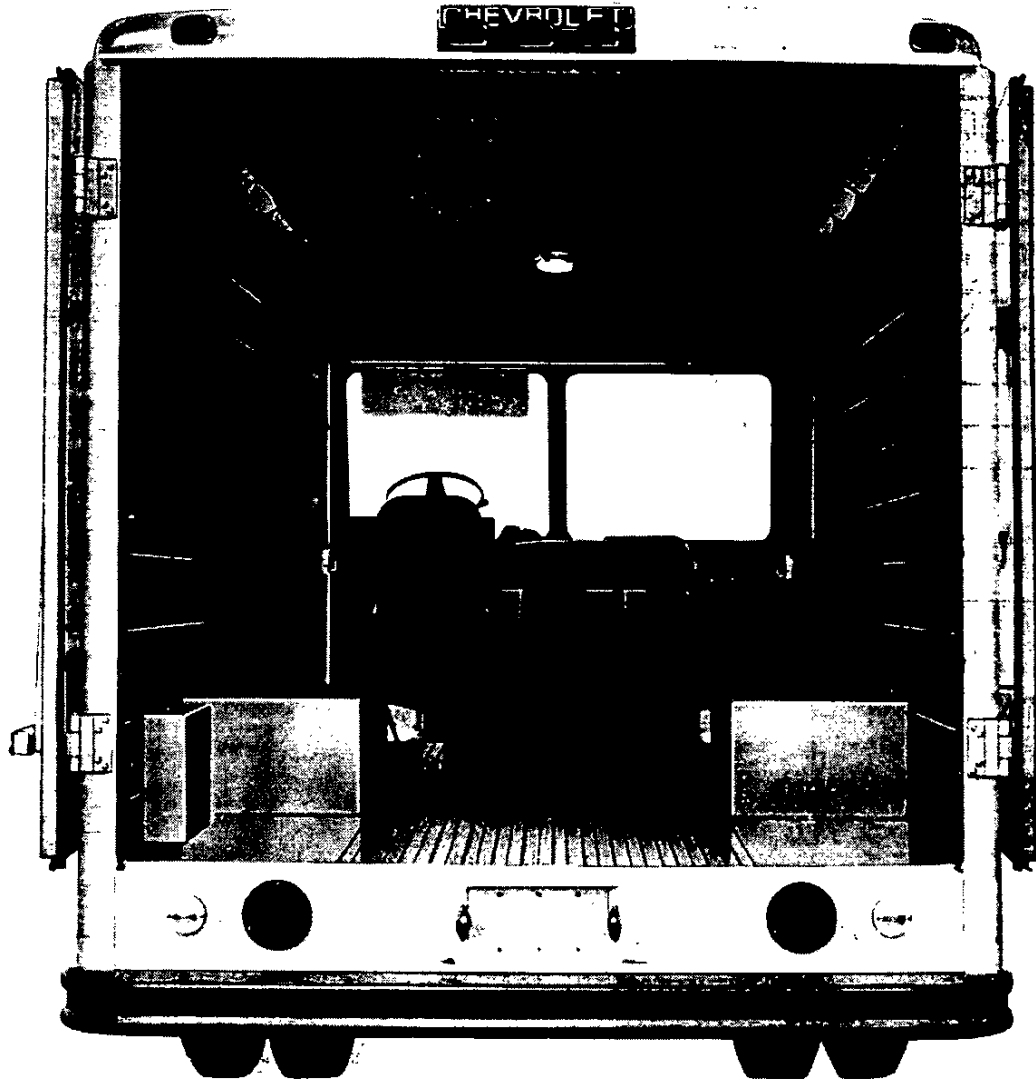

Steel panels line the body interior, providing a smooth surface that is both durable and practical. One inch thick fiberglass pads are used between the inner and outer panels of the sides, rear end and roof for sound deadening and insulation against heat and cold. The load compartment floor is constructed of 18-gage steel with corrugated center panel for rugged strength and ease in sliding loads in and out. The wheelhousings are rectangular for simplicity when loading all around them. A smooth floor of 11-gage steel is also available optionally.

The double-wall constructed sliding front doors are completely enclosed in door pockets when opened, which prevent objects from wedging or interfering with their sliding operation. An outside key lock is provided for the passenger side door. The glass in the driver side door is the aluminum-framed sliding type while the passenger side has fixed glass. Sliding glass is available for this window as an option.

The rear bumper has a treadplate type upper surface to give safer footing while climbing in and out of the load space.

Double rear doors with a window in each and a total width of 38" are standard. The right-hand door has an inside latch which engages at both the top and bottom and can be operated either by an inside handle or an outside key-locking handle. The left hand door has an inside latch at the top. Optional rear doors include double rear doors similar to the standard ones, but with a 60" width. Also available is a 74" wide wrap-around door option with strap hinges. Extensive corrosion protection measures are employed, including use of corrosion-resistant steels, special sealers, corrosion-resistant coatings or fasteners, and underbody coatings.

# STEP-VAN/VALUE VAN

## STEP-VAN/VALUE VAN—STEEL

### DIMENSIONS

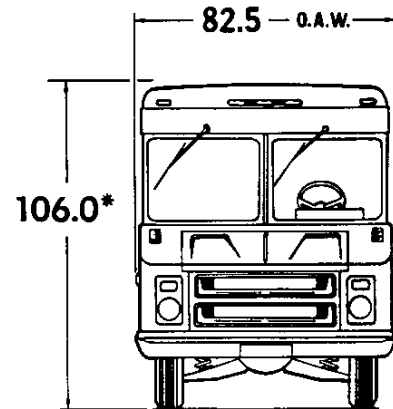
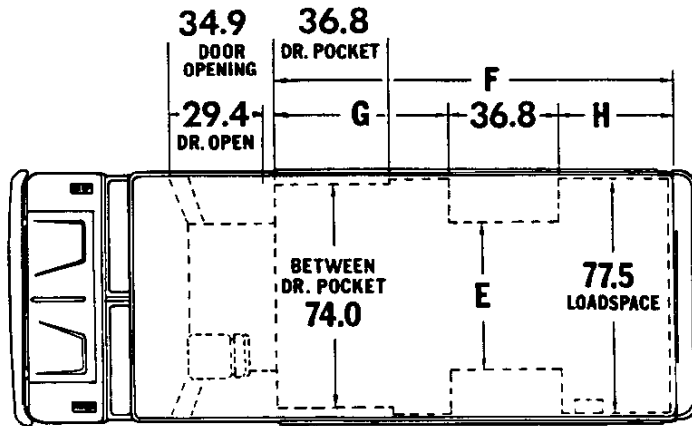
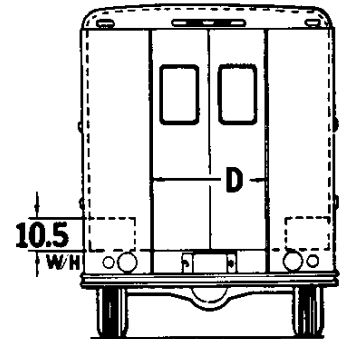
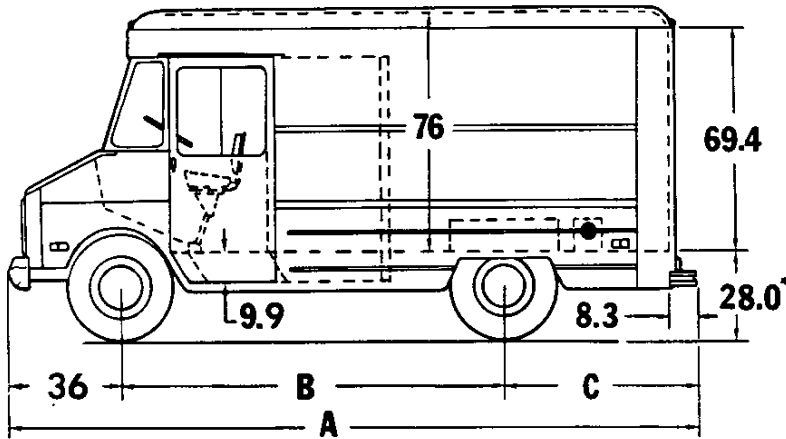

DIMENSIONS With Standard Equipment, Unloaded	Model Availability		
	Body Ordering Code - E32		
	P208-30842	P210-31042	P31442
	Body Length		
	Std 10'6"	Std 12'6"	Std 14'6"
A Overall Length (In)	226.7	250.7	274.7
B Wheelbase (In)	125	133	157
C Rear Overhang (In)	65.7	81.7	81.7
D Standard Rear Door Width (In)	38	38	38
Optional Rear Door Width (In)	60	60	60
Optional Rear Door Width (In)	74.1	74.1	74.1
E Width Between Wheelhousings—Single Rear (In)	48	48	48
Optional—with Dual Rear Wheels (In)	40	40	40
F Overall Load Space Length (In)	129.6	153.6	177.6
G Front of Wheelhousing (In)	55.6	63.6	87.6
H Rear of Wheelhousing (In)	37.2	53.2	53.2
Cubic Capacity (Cu Ft)	415.5	496.5	577.5
Sign Panel Area (In x In)	54 x 125.5	54 x 149.5	54 x 173.5

\*This dimension varies depending on spring, tire and wheel size.

## STEP-VAN/VALUE VAN

### STEP-VAN/VALUE VAN—ALUMINUM

#### GENERAL FEATURES

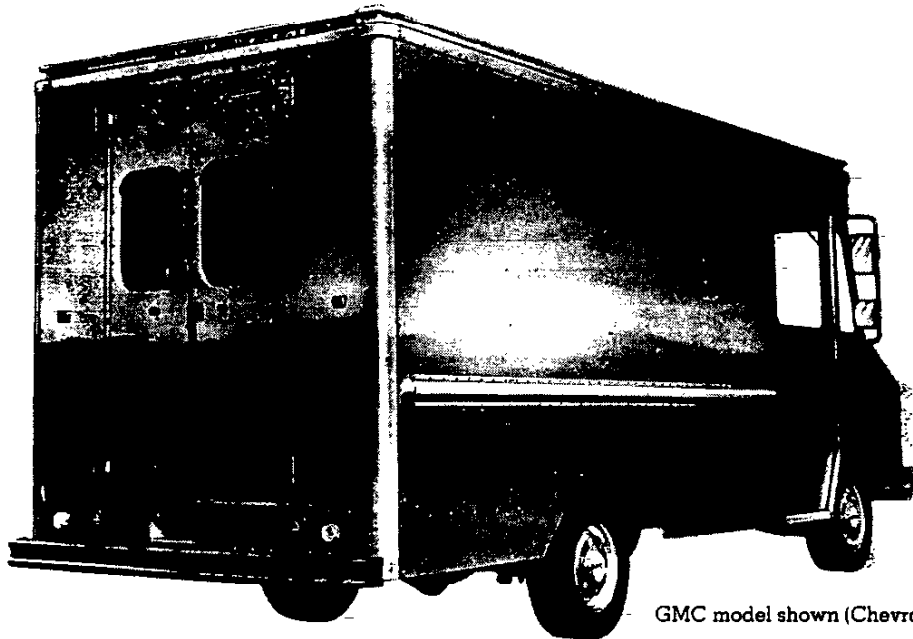

GMC model shown (Chevrolet model available)

Step-Van/Value Van Aluminum models are available in standard nominal lengths of ten feet six inches and twelve feet six inches on P20/2500 Series and ten feet six inches, twelve feet six inches, and fourteen feet six inches on P30/3500 Series. Body construction is of aluminum extrusions forming a rigid integral framework, covered with riveted heavy-gage aluminum panels which can be removed for repair or replacement if damaged. The light weight and freedom from rust offer more efficient transport of goods and lower body maintenance costs. Payload capacity is greater than that of a comparable steel van.

All Step-Van/Value Van Aluminum models feature square front end styling with a front opening hood for better engine access. Front and rear side marker

lights, roof-mounted identification and clearance lights are standard as are left-hand and right-hand outside dual-head rearview mirrors and rear door glass.

One-piece steel bathtub-type front wheelhousings help to protect the body from road splash, and a one-piece steel radiator support helps to strengthen overall structural rigidity. The hood panel is thick aluminum with liberal reinforcement by especially designed extrusions, and is secured by a two-position plunger automotive type latch.

Optional increases in width and height are available, either separately or in combination with each other, making a total of six possible body sizes on each wheelbase. See the chart on the dimension page for dimensions and cubic capacities of all the bodies.

#### SERVICE FEATURES

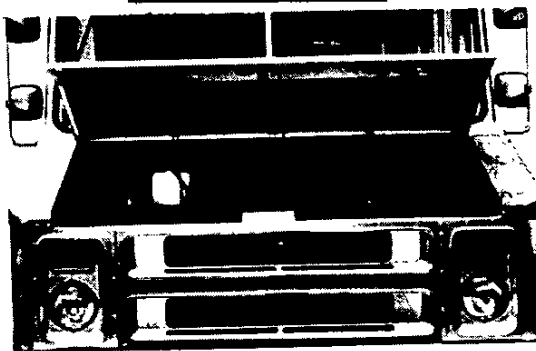

Chevrolet model shown  
(GMC model available)

The design features a front opening hood for better service access to the engine, battery, radiator and other chassis items.

*Note: See white tabs Special Equipment For Union City Bodies and Special Equipment Options for a listing of special items.*



# STEP-VAN/VALUE VAN

## STEP-VAN/VALUE VAN—ALUMINUM BODY FEATURES



Embossed aluminum headlining with 1" insulation is standard. Driver's compartment header trim panels with access plates provide a finished appearance without reducing service ease. Unobstructed load space features rectangular wheelhousings for simplicity in loading. The load compartment floor is smooth for ease in sliding loads in and out.

The solid laminate sliding front doors are completely enclosed in rigid corrugated door pockets when opened, which prevent objects from wedging or interfering with their sliding operation.

An aluminum-framed sliding window is standard in the driver's side door, while the passenger's side has fixed glass. Sliding glass is available for this window as an option.

The steel rear bumper has a treadplate-type upper surface to give safer footing while entering or leaving the load space.

Double rear doors with a window in each and a total width of 38" are standard. The left-hand door has an inside latch at the top, while the right-hand door utilizes a latch which engages at both the top and bottom and can be operated either by an inside handle or an outside key-locking handle. Heavy-duty hardware is standard and both the right side and rear doors have outside key locks keyed alike. Rugged heavy-duty strap hinges are also standard.

Optional rear doors include double rear doors similar to the standard doors but with a 60" width. Also available are three wrap-around door options in widths of 74," 83," and 87." The 83" door option is available only with the optional 9" additional body width, while the 87" door option is available only with the optional 13" additional body width.

The underside of the body, front and rear wheelhousings, and side panels below floor level are fully undercoated.

# STEP-VAN/VALUE VAN

## STEP-VAN/VALUE VAN—ALUMINUM

### DIMENSIONS

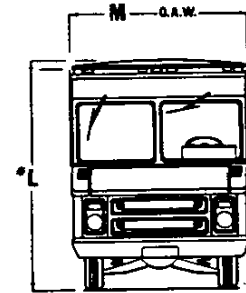
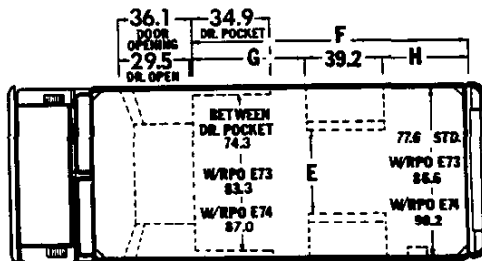
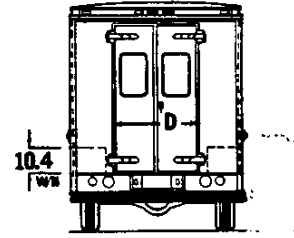
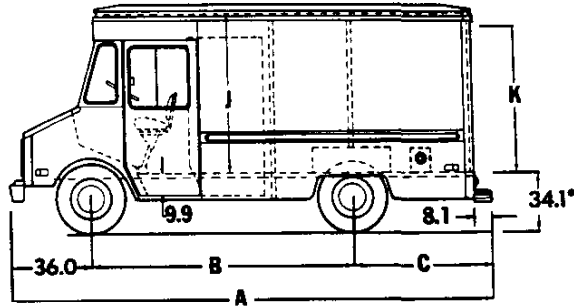

<b>DIMENSIONS</b> With Standard Equipment, Unloaded	<b>Model Availability</b>			
	<b>Body Ordering Code - E33</b>			
	<b>P208-30842</b>	<b>P210-31042</b>	<b>P31442</b>	<b>P31842</b>
	<b>Body Length</b>			
	<b>Std 10'6"</b>	<b>Std 12'6"</b>	<b>Std 14'6"</b>	<b>Std 18'</b>
A Overall Length (In)	226.6	250.6	274.6	316.6
B Wheelbase (In)	125	133	157	178
C Rear Overhang (In)	65.6	81.6	81.6	102.6
D Standard Rear Door Width (In) Optional Rear Door Widths (In)	38 60, 73, 82, 85.7	38 60, 73, 82, 85.7	38 60, 73, 82, 85.7	38 60, 73, 82, 85.7
E Width Between Wheelhousings—Single Rear (In) Optional—with Dual Rear Wheels (In)	48 40	48 40	48 40	— 40
F Overall Loadspace Length (In)	128	152	176	218
G Front of Wheelhousing (In)	54.5	62.5	86.5	107.5
H Rear of Wheelhousing (In)	34.3	50.3	50.3	71.3
J Standard Interior Height (In) Optional Interior Height (In)	76.2 80.2	76.2 80.2	76.2 80.2	76.2 80.2
K Standard Rear Door Height (In) With Optional 80" Interior Height (In)	70 74	70 74	70 74	70 74
*L Standard Overall Height (In) With Optional 80" Interior Height (In)	113.7 117.7	113.7 117.7	113.7 117.7	113.7 117.7
M Standard Overall Width (In) With Optional 9" Additional Width With Optional 13" Additional Width	83.1 92.1 95.8	83.1 92.1 95.8	83.1 92.1 95.8	83.1 92.1 95.8
Cubic Capacity (Ft)			<b>Std 14'6"</b> <b>Opt 15'6"</b> <b>Opt 16'</b>	
With Standard 76" Interior Height	421.5	501.5	583.5   624.4   644.9	726.5
With 9" Additional Body Width	469.5	560.5	652.5   698.1   720.9	811.5
With 13" Additional Body Width	488.5	583.5	679.5   727.3   751.1	845.5
With Optional 80" Interior Height	443.5	529.5	615.5   658.6   680.1	765.5
With 9" Additional Body Width	493.5	590.5	686.5   734.5   758.5	853.5
With 13" Additional Body Width	515.5	615.5	715.5   765.8   790.9	890.5
Standard Sign Panel Area (In x In) With Optional 80" Interior Height (In x In)	54 x 125.5 58 x 125.5	54 x 149.5 58 x 149.5	54 x 173.5 58 x 173.5	54 x 215.5 58 x 215.5

\*This dimension varies depending on spring, tires and wheel size.

# STEP-VAN/VALUE VAN

## STEP-VAN/VALUE VAN BODY CONSTRUCTION

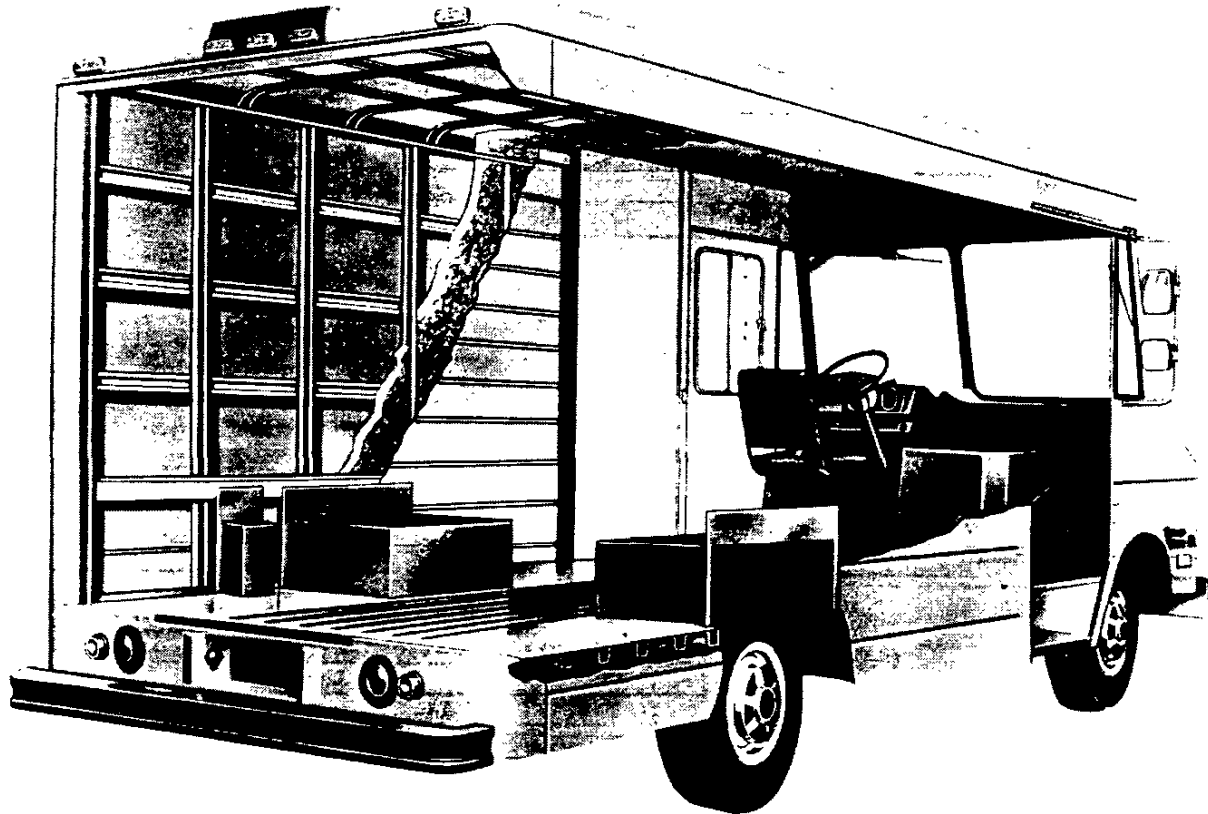

### STEEL BODIES

The Step-Van/Value Van Steel bodies consist of six major fabricated assemblies; the front end, floor, right and lefthand sides, roof, and rear end. Each of these assemblies consists of a rigid framework of heavy, stamped structural members with the outer skin panels joined to them by welding. The six major assemblies are positioned in massive welding fixtures that align and hold all structural members and panels rigidly and accurately to insure uniformity during final welding and assembly.

Prior to final assembly the sub-assemblies are run through a three-stage acid, phosphate and water wash to remove oil and prepare the surfaces for painting. Any areas which will be hidden during the assembly process are then primed, which includes most of the inner surfaces and the underfloor structure.

To resist corrosion, extensive use is made of weld-through primers and all coach seams and joints are thoroughly sealed. The exterior body panels, front

stepwells and rear wheelhouses are fabricated of iron-zinc alloy steel, and the chassis splash fenders are integrated into the front end structure to afford additional protection from road splash. Corrosion-resistant coatings are used on fasteners, with cadmium-plated rear door strap hinges.

The major body assemblies are then mounted on the chassis, and are joined by bolting, welding and riveting. Mastic is applied to the inside of the body shell and one inch-thick fiberglass mats applied in the roof, sides and rear end. Steel interior trim panels are primed on both sides before installation.

The Step-Van/Value Van body is then primed and baked in a two-stage oven before the finish coat is applied. The interior is finished in grey hammertone and the exterior is finished in highgloss enamel and are again baked in two-stage ovens. The underbody is then undercoated in its entirety, and rustproofing compound applied to the interior and side doors to inhibit corrosion.

# STEP-VAN/VALUE VAN

## STEP-VAN/VALUE VAN

### BODY CONSTRUCTION

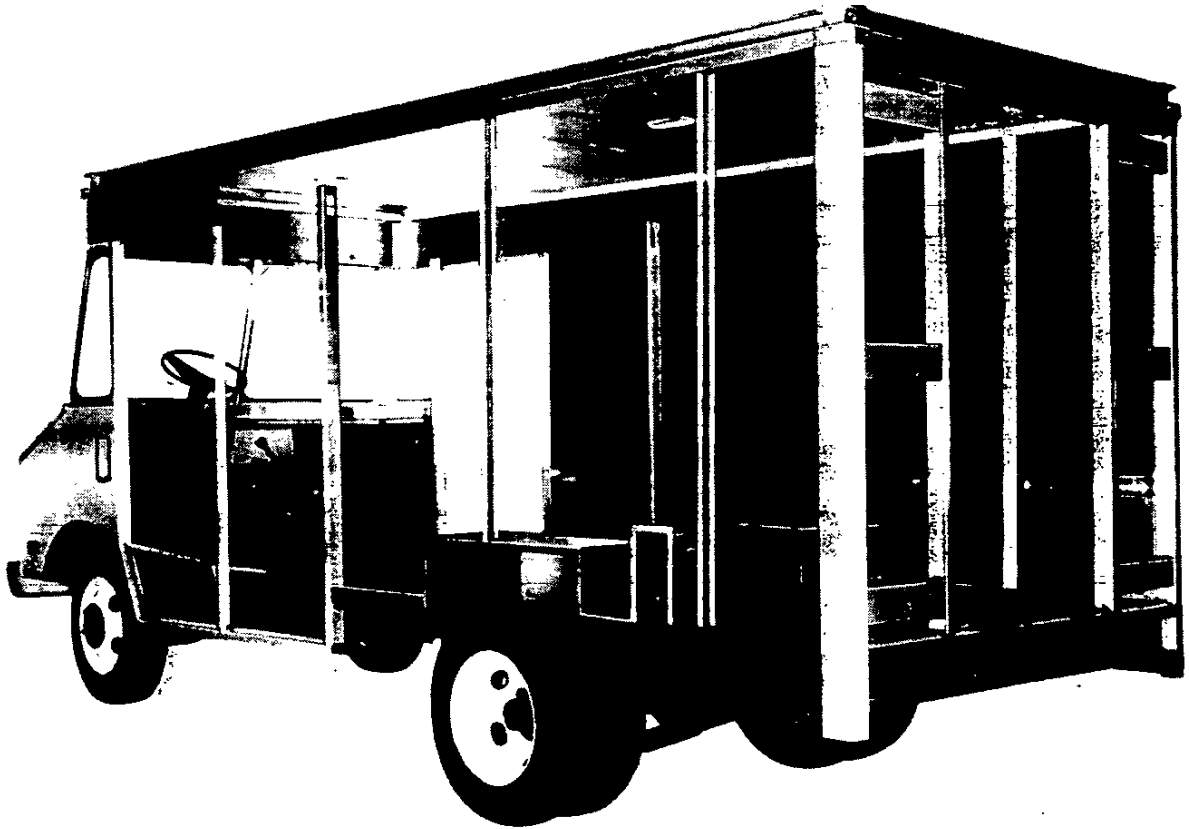

### ALUMINUM BODIES

The Step-Van/Value Van Aluminum with aluminum body features complete framing of the body with aluminum extrusions. All extrusions are joined, by riveting or welding, to form an extremely rigid integral framework. These extrusions are designed for their specific application.

Special alloy body panels are riveted to this extrusion framework and can be removed for repair or replacement.

The aluminum load floor panels are smooth. Wheelhousing structure is of heavy aluminum sheet reinforced and welded together to form a strong rectangular box. Floor panels are welded to transverse cross-sills of sturdy hat-shaped aluminum extrusions, with the wheelhousings riveted into the assembly. Cross-sill spacing is closer at the rear of the loadspace floor, where loading impacts are greatest.

The front end structure consists of specially designed aluminum extrusions, riveted and welded together to form a rugged framework. The outer skin of aluminum sheet is riveted to the frame structure. The front opening hood is reinforced aluminum. The driver's compartment floor rearward of the seat and step area of the stepwells are of aluminum treadplate.

The sides are of frame and skin construction. Special alloy aluminum sheet panels are riveted to the extrusion framework, wheelhousings, floor, and a sturdy half-round crash rail to form rigid structures.

The roof is built around symmetrical side, front and rear extrusions. At each corner the extrusions bolt to castings designed to fit this complex shape. The outer skin is a flat sheet which is rolled over the extrusion flanges around its outer edge, with all rivets being outside the roof structure to prevent leaks. Transverse roof bows of H-shaped extrusions provide support for the outer skin.

The rear end is a riveted and welded assembly of aluminum panels and heavy-duty extrusions. The rear door frames are special complex shaped extrusions, miter cut and welded. Thick aluminum exterior panels are riveted to these frames, and inner reinforcements support door hinges and hold-open stops.

A sturdy steel transmission cross-sill assembly and one-piece steel bathtub front wheelhousings are shared with the steel Step-Van/Value Van and afford even greater rigidity and protection to the front end assembly.

## STEP-VAN/VALUE VAN

### INTERIOR AND EXTERIOR COLOR AVAILABILITY CHART

**Note:** For Special Paint Applications Please Contact the Zone Office. When dealer arrangements for special paint have been made with Union City Body Company, Code 0101 must be added to the primary and secondary paint area of dealer order. Seat(s) are trimmed in Dark Red grained vinyl.

EXTERIOR COLORS	Primary	Secondary	Interior Color Silver
BLUE, GALAXY (Metallic)	28	28	X
BLUE, LIGHT (Metallic)	21	21	X
BRONZE, INDIAN (Metallic)	66	66	X
RED, APPLE	72	72	X
RED, AUTUMN (Metallic)	76	76	X
SAND, DESERT (Metallic)	64	64	X
SILVER (Metallic)	16	16	X
TAN, DOESKIN	61	61	X
WHITE, FROST	12	12	X
YELLOW, COLONIAL	53	53	X
BODY, BARE ALUMINUM (Aluminum Step-Van/Value Van Only)	02	02	X
BODY IN PRIME	00	00	X

### SOLID PAINT—ZY1

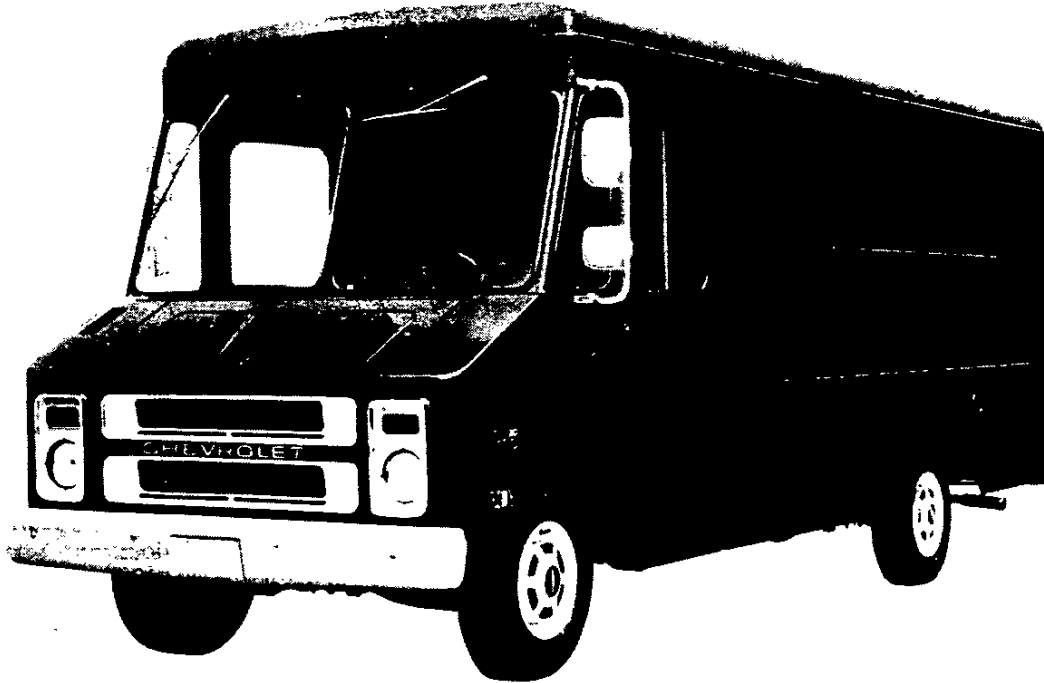

### FC CHASSIS EXTERIOR COLOR CODE CHART

EXTERIOR COLOR	Primary	Secondary
SPECIAL PAINT	01	01

