

MVMA Specifications Form Passenger Car

METRIC (U.S. Customary)

Car Line CHEVROLET
 Model Year 1987 Issued 6-86 Revised (e) _____

Car Models

Model Description & Drive (FWD/RWD)	Introduction Date	Make, Car Line, Series, Body Type (Mfr's Model Code)	No. of Designated Seating Positions (Front/Rear)		Max. Trunk/Cargo Load-Kilograms (Pounds)
Rear Wheel Drive Chevrolet		Model Number	Front/Rear-3rd		
Caprice					
4-Door Sedan		1BL69	3	3	90.7 (200.0)
4-Door Station Wagon, 3-Seat		1BL35	3	3-2	0 (0)
Caprice Classic					
4-Door Sedan		1BN69	3	3	90.7 (200.0)
2-Door Coupe		1BN47	3	3	90.7 (200.0)
4-Door Station Wagon, 3-Seat		1BN35	3	3-2	0 (0)
Caprice Classic Brougham 4-Door Sedan		1BU69	3	3	90.7 (200.0)

NOTE: Any Specifications on the following pages specific to California requirements are indicated accordingly.

MVMA Specifications Form Passenger Car

Car Line CHEVROLET
 Model Year 1987 Issued 6-86 Revised (●) 9-86

METRIC (U.S. Customary)

Power Teams (Indicate whether standard or optional)

SAE J1349 Net bhp (brake horsepower) and net torque corrected to 77°F/25° C and 29.61 in. Hg/100 kPa atmospheric pressure.

SERIES AVAILABILITY	ENGINE					E x h a u s t S D	TRANSMISSION/ TRANSAXLE	DRIVE RATIOS (:1) AXLE RATIO @			
	Displ. Liters (in ³)	Carb. (Barrels, FI, etc.)	Compr. Ratio	SAE Net at RPM				Base Veh. Drive	Opt. Veh. Drive	Overall Opt. Veh. Drive	Overall Opt. Veh. Drive
Power kW (bhp)				Torque N·m (lb. ft.)							
Base - All States Sedans & Coupe	V6 4.3Liter (262CID) LB4	EFI *	9.3:1	(140	(225	S	Auto '200-3c' Base (MV9)	2.56	2.56	--	--
				@ 4200)	@ 2000)		Auto '700-R4' Opt. (MD8)	2.56	1.79	3.08\$	2.16
Optional All States Sedans & Coupe	V8 5.0Liter (305CID) LG4	4- Bbl	9.3:1	(170	(250	S	Auto-700-R4 - Base (MD8)	2.56	1.79	3.08\$	2.16
				@ 4400)	@ 2800)		Auto-200-4R - Opt. (MW9)	2.73	1.83	3.08\$	2.06
Base - All States Wagons Only	V8 5.0Liter (307CID) LV2	4- Bbl	8.0	(140 @ 3200)	(255 @ 2000)	S	Auto-'200-4R' Base (MW9)	2.73	1.83	3.08\$	2.06 3.23\$ 2.16
<p>@ - 191mm (7-1/2") ring gear for coupe and sedans with base axles; 216 mm (8-1/2") ring gear for wagons, seo vehicles, limited slip axles and optional axle ratios. * - Electronic Fuel Injection. \$ - Optional Axle Ratio</p>											

MVMA Specifications Form Passenger Car

Car Line CHEVROLET
Model Year 1987 Issued 6-86 Revised (e) 9-86

METRIC (U.S. Customary)

Engine Description/Carb.
Engine Code

4.3 Liter V6 (262 CID)
(Electronic Fuel Injection)
RPO LB4

ENGINE - GENERAL

Type & description (inline, V, angle, flat, location, front, mid, rear, transverse, longitudinal, sohc, dohc, ohv, hemi, wedge, pre-camber, etc.)	90° "V" - Front - Longitudinal Number of mounting points Two - Front One - Rear	
Manufacturer	Chevrolet	
No. of cylinders	6	
Bore	101.60 (4.00)	
Stroke	88.39 (3.48)	
Bore spacing (C/L to C/L)	111.80 (4.4)	
Cylinder block material & mass kg (lbs.) (machined)	Cast alloy iron 46.500 (102.5) (machined)	
Cylinder block deck height	Not Available	
Cylinder block length	Not Available	
Deck clearance (minimum) (above or below block)	Not Available	
Cylinder head material & mass kg (lbs.)	Cast alloy iron 16.330 (36.0)	
Cylinder head volume (cm ³)	Not Available	
Cylinder liner material	Not Available	
Head gasket thickness (compressed)	.0210	
Minimum combustion chamber total volume (cm ³)	Not Available	
Cyl. no. system (front to rear)*	L. Bank	1-3-5
	R. Bank	2-4-6
Firing order	1-6-5-4-3-2	
Intake manifold material & mass [kg (lbs.)]**	Cast aluminum/5.000 (11.0)	
Exhaust manifold material & mass [kg (lbs.)]**	Stainless steel/3.146 (6.9) R.H., 2.141 (4.7) L.H.	
Recommended fuel (leaded, unleaded, diesel)	Unleaded	
Fuel antiknock index (R + M) 2	87	
Total dressed engine mass (wt) dry***	216.1 (476.4)	

Engine - Pistons

Material & mass, g (weight, oz.) - piston only	Cast aluminum alloy .598 (1.318)
--	-------------------------------------

Engine - Camshaft

Location	In block above crankshaft	
Material & mass kg (weight, lbs.)	Steel/3.171 (7.0)	
Drive type	Chain / belt	Chain
	Width / pitch	Not Available

* Rear of engine - drive takeoff. View from drive takeoff end to determine left & right side of engine.

** Finished state.

*** Dressed engine mass (weight) includes the following:

MVMA Specifications Form Passenger Car

Car Line CHEVROLET
 Model Year 1987 Issued 6-86 Revised (●) 9-86

METRIC (U.S. Customary)

Engine Description/Carb.
 Engine Code

5.0 Liter V8 (305 CID)
 4-Bbl. Carburetor
 RPO LG4

ENGINE - GENERAL

Type & description (inline, V, angle, flat, location, front, mid, rear, transverse, longitudinal, sohc, dohc, ohv, hemi, wedge, pre-camber, etc.)	90° "V" - Front - Longitudinal	
	Number of mounting points	
	Two - Front	
	One - Rear	
Manufacturer	Chevrolet	
No. of cylinders	8	
Bore	94.89 (3.74)	
Stroke	88.39 (3.48)	
Bore spacing (C/L to C/L)	111.8 (4.40)	
Cylinder block material & mass kg (lbs.) (machined)	Cast alloy iron 68.674 (151.4)	
Cylinder block deck height	229.4 (9.025)	
Cylinder block length	Not Available	
Deck clearance (minimum) (above or below block)	.635 (.025) below	
Cylinder head material & mass kg (lbs.)	Cast alloy iron 19.800 (43.7)	
Cylinder head volume (cm ³)	Not Applicable	
Cylinder liner material	Not Available	
Head gasket thickness (compressed)	.533 (.021)	
Minimum combustion chamber total volume (cm ³)	Not Available	
Cyl. no. system (front to rear)*	L. Bank	1-3-5-7
	R. Bank	2-4-6-8
Firing order	1-8-4-3-6-5-7-2	
Intake manifold material & mass [kg (lbs.)]**	Iron 18.733 (41.3)	
Exhaust manifold material & mass [kg (lbs.)]**	Cast iron 3.900 (8.6) L.H., 3.800 (8.4) R.H.	
Recommended fuel (leaded, unleaded, diesel)	Unleaded	
Fuel antiknock index (R + M)	87	
	2	
Total dressed engine mass (wt) dry***	262.7 (579.1)	

Engine - Pistons

Material & mass, g (weight, oz.) - piston only	Cast aluminum alloy .502 (1.107)
--	-------------------------------------

Engine - Camshaft

Location	In block above crankshaft	
Material & mass kg (weight, lbs.)	Steel 4.124 (9.1)	
Drive type	Chain / belt	Chain
	Width / pitch	15.87 (.625) / 12.7 (.500)

* Rear of engine - drive takeoff. View from drive takeoff end to determine left & right side of engine.

** Finished state.

*** Dressed engine mass (weight) includes the following:

All those items necessary to make the engine a complete ready-to-run unit.

Aluminum Intake

MVMA Specifications Form Passenger Car

Car Line CHEVROLET
 Model Year 1987 Issued 6-86 Revised (*) 9-86

METRIC (U.S. Customary)

Engine Description/Carb.
 Engine Code

5.0 Liter V8 (307 CID)
 4-Bbl. Carburetor
 RPO LV2

ENGINE - GENERAL

Type & description (inline, V, angle, flat, location, front, mid, rear, transverse, longitudinal, sohc, dohc, ohv, hemi, wedge, pre-camber, etc.)		90° "V", Front, Longitudinal
Manufacturer		Oldsmobile
No. of cylinders		8
Bore		96.50 (3.800)
Stroke		85.98 (3.385)
Bore spacing (C/L to C/L)		117.5 (4.625)
Cylinder block material & mass kg (lbs.) (machined)		Cast iron 72.600 (160.1)
Cylinder block deck height		237 (9.330)
Cylinder block length		Not Available
Deck clearance (minimum) (above or below block)		.29 below (.0116 in.)
Cylinder head material & mass kg (lbs.)		Cast iron 22.00 (48.5)
Cylinder head volume (cm ³)		63.45 (3.87)
Cylinder liner material		Not Available
Head gasket thickness (compressed)		1.07 (.042 +/- .002)
Minimum combustion chamber total volume (cm ³)		86.05 (5.25)
Cyl. no. system (front to rear)*	L. Bank	1-3-5-7
	R. Bank	2-4-6-8
Firing order		1-8-4-3-6-5-7-2
Intake manifold material & mass [kg (lbs.)]**		Aluminum 8.650 (19.1)
Exhaust manifold material & mass [kg (lbs.)]**		Steel L.H. 2.120 (4.7), R.H. 3.150 (6.9)
Recommended fuel (leaded, unleaded, diesel)		Unleaded
Fuel antiknock index (R + M)	2	87
Total dressed engine mass (wt) dry***		285.4 (629.2)

Engine - Pistons

Material & mass, g (weight, oz.) - piston only	Aluminum alloy 564.2 (19.9)
--	--------------------------------

Engine - Camshaft

Location	Center	
Material & mass kg (weight, lbs.)	Cast iron 5.000 (11.0)	
Drive type	Chain / belt	Gear to gear; direct drive
	Width / pitch	18.29-19.05 (.720-.750)/12.7 (.500)

* Rear of engine - drive takeoff. View from drive takeoff end to determine left & right side of engine.
 ** Finished state.
 *** Dressed engine mass (weight) includes the following:

MVMA Specifications Form Passenger Car

Car Line CHEVROLET
 Model Year 1987 Issued 6-86 Revised (e) _____

METRIC (U.S. Customary)

Engine Description/Carb.
 Engine Code

4.3 Liter V6 (262 CID)
 (Electronic Fuel Injection)
 RPO LB4

Engine - Valve System

Hydraulic lifters (std., opt., NA)	Standard	
Valves	Number intake / exhaust	6/6
	Head O.D. intake / exhaust	49.28 (1.94)/38.10 (1.50)

Engine - Connecting Rods

Material & mass [kg., (weight, lbs.)]*	1141 Steel/forging/.388 (0.85)
--	--------------------------------

Engine - Crankshaft

Material & mass [kg., (weight, lbs.)]*	Nodular cast iron/17.500 (38.6)	
End thrust taken by bearing (no.)	4	
Number of main bearings	4	
Seal (material, one, two piece design, etc.)	Front	
	Rear	

Engine - Lubrication System

Normal oil pressure [kPa (psi) at engine rpm]	345-488 (50-65 @ 2000)
Type oil intake (floating, stationary)	Stationary
Oil filter system (full flow, part, other)	Full flow
Capacity of c/case, less filter-refill-L (qt.)	3.8 (4.0)

Engine - Diesel Information

Diesel engine manufacturer		
Glow plug, current drain at 0°F		Not
Injector nozzle	Type	
	Opening pressure (kPa (psi))	Applicable
Pre-chamber design		
Fuel injection pump	Manufacturer	
	Type	
Fuel injection pump drive (belt, chain, gear)		
Supplementary vacuum source (type)		
Fuel heater (yes/no)		
Water separator, description (std., opt.)		
Turbo manufacturer		
Oil cooler-type (oil to engine coolant; oil to ambient air)		
Oil filter		

Engine - Intake System

Turbo charger - manufacturer	Not
Super charger - manufacturer	Applicable
Charge cooler	--

*Finished State

MVMA Specifications Form Passenger Car

Car Line CHEVROLET
 Model Year 1987 Issued 6-86 Revised (●) _____

METRIC (U.S. Customary)

Engine Description/Carb.
Engine Code

5.0 Liter V8 (305 CID)
4-Bbl. Carburetor
RPO LG4

Engine - Valve System

Hydraulic lifters (std., opt., NA)	Standard
Valves	Number intake / exhaust
	Head O.D. intake / exhaust

8/8
46.74(1.84)/38.10(1.50)

Engine - Connecting Rods

Material & mass [kg., (weight, lbs.)]*	1037 or 1038 steel/.388 (.855)
--	--------------------------------

Engine - Crankshaft

Material & mass [kg., (weight, lbs.)]*	Nodular Cast Iron/23.360(51.50)
End thrust taken by bearing (no.)	5
Number of main bearings	5
Seal (material, one, two piece design, etc.)	Front
	Rear

Engine - Lubrication System

Normal oil pressure [kPa (psi) at engine rpm]	345-488 (50-65) @ 2000
Type oil intake (floating, stationary)	Stationary
Oil filter system (full flow, part, other)	Full flow
Capacity of c/case, less filter-refill-L (qt.)	4.5 (5.0)

Engine - Diesel Information

Diesel engine manufacturer		
Glow plug, current drain at 0°F		
Injector nozzle	Type	Not Applicable
	Opening pressure [kPa (psi)]	
Pre-chamber design		
Fuel injection pump	Manufacturer	
	Type	
Fuel injection pump drive (belt, chain, gear)		
Supplementary vacuum source (type)		
Fuel heater (yes/no)		
Water separator, description (std., opt.)		
Turbo manufacturer		
Oil cooler-type (oil to engine coolant; oil to ambient air)		
Oil filter		

Engine - Intake System

Turbo charger - manufacturer	Not
Super charger - manufacturer	Applicable
Charge cooler	

*Finished State

MVMA Specifications Form Passenger Car

Car Line CHEVROLET
 Model Year 1987 Issued 6-86 Revised (•) 9-86

METRIC (U.S. Customary)

Engine Description/Carb.
 Engine Code

5.0 Liter V8 (307 CID)
 4-Bbl. Carburetor
 RPO LV2

Engine - Valve System

Hydraulic lifters (std., opt., NA)		Standard
Valves	Number intake / exhaust	8/8
	Head O.D. intake / exhaust	44.45(1.75)/38.15(1.502)

Engine - Connecting Rods

Material & mass (kg., (weight, lbs.))*	Steel SAE #1140 .625 (1.4)
--	----------------------------

Engine - Crankshaft

Material & mass (kg., (weight, lbs.))*	Steel 22.400 (49.4)	
End thrust taken by bearing (no.)	3	
Number of main bearings	5	
Seal (material, one, two piece design, etc.)	Front	
	Rear	

Engine - Lubrication System

Normal oil pressure (kPa (psi) at engine rpm)	207-310 (30-45) @ 1500 RPM
Type oil intake (floating, stationary)	Stationary
Oil filter system (full flow, part, other)	Full flow
Capacity of c/case, less filter-refill-L (qt.)	3.75 (4.0) - 5 Qts. w/filter

Engine - Diesel Information

Diesel engine manufacturer	
Glow plug, current drain at 0°F	Not Applicable
Injector nozzle	Type
	Opening pressure (kPa (psi))
Pre-chamber design	
Fuel injection pump	Manufacturer
	Type
Fuel injection pump drive (belt, chain, gear)	
Supplementary vacuum source (type)	
Fuel heater (yes/no)	
Water separator, description (std., opt.)	
Turbo manufacturer	
Oil cooler-type (oil to engine coolant; oil to ambient air)	
Oil filter	

Engine - Intake System

Turbo charger - manufacturer	Not
Super charger - manufacturer	Applicable
Charge cooler	--

*Finished State

MVMA Specifications Form Passenger Car

Car Line CHEVROLET
 Model Year 1987 Issued 6-86 Revised (e) _____

METRIC (U.S. Customary)

Engine Description/Carb.
 Engine Code

4.3 Liter V6 (262 CID)
 (Electronic Fuel Injection)
 RPO LB4

Engine - Cooling System

Coolant recovery system (std., opt., n.a.)		Standard		
Coolant fill location (rad., bottle)		Bottle		
Radiator cap relief valve pressure [kPa (psi)]		103.4 (15.0)		
Circulation thermostat	Type (choke, bypass)	Choke		
	Starts to open at °C (°F)	91 (195)		
Water pump	Type (centrifugal, other)	Centrifugal		
	GPM 1000 pump rpm	--		
	Number of pumps	One		
	Drive (V-belt, other)	V-belt		
	Bearing type	Sealed double row ball		
	Impeller material			
	Housing material			
By-pass recirculation [type (inter., ext.)]		Internal		
Cooling system capacity	With heater-L.(qt.)	11.51 (12.2)		
	With air cond.-L.(qt.)	11.43 (12.1)		
	Opt. equipment (specify-L.(qt.))	11.89 (12.6)		
Water jackets full length of cyl. (yes, no)		Yes		
Water all around cylinder (yes, no)		Yes		
Water jackets open at head face (yes, no)				
Radiator core	Std., A/C, HD	Std.	A/C	H.D.
	Type (cross-flow, etc.)	Cross flow		
	Construction (fin & tube mechanical, braze, etc.)			
	Material, mass [kg (wtg. lbs.)]	Copper-brass, high efficiency radiator		
	Width	529.1	529.1	529.1
	Height	429.7	429.7	429.7
	Thickness	25.0	25.0	40.2
	Fins per inch *	2.5	3.0	3.0
Radiator end tank material				
Fan	Std., elec., opt.	Std.	A/C	
	Number of blades & type (flex, solid, material)	4, Steel, Solid	5, Aluminum, Solid	
	Diameter & projected width	482.6	508.0	
	Ratio (fan to crankshaft rev.)	--	--	
	Fan cutout type	--	Clutch	
	Drive type (direct, remote)	V-Belt	V-Belt	
	RPM at idle (elec.)	--	--	
	Motor rating (wattage) (elec.)	--	--	
	Motor switch (type & location) (elec.)	--	--	
	Switch point (temp., pressure) (elec.)	--	--	
	Fan shroud (material)	Plastic	Plastic	

* - Distance between top of fins

MVMA Specifications Form Passenger Car

Car Line CHEVROLET
 Model Year 1987 Issued 6-86 Revised (•) _____

METRIC (U.S. Customary)

Engine Description/Carb. 5.0 Liter V8 (305 CID)
 Engine Code 4-Bbl. Carburetor
RPO LG4

Engine - Cooling System

Coolant recovery system (std., opt., n.a.)		Standard		
Coolant fill location (rad., bottle)		Bottle		
Radiator cap relief valve pressure [kPa (psi)]		103.4 (15.0)		
Circulation thermostat	Type (choke, bypass)	Choke		
	Starts to open at °C (°F)	91 (195)		
Water pump	Type (centrifugal, other)	Centrifugal		
	GPM 1000 pump rpm	14		
	Number of pumps	One		
	Drive (V-belt, other)	V-belt		
	Bearing type	Sealed double row ball		
	Impeller material			
	Housing material			
By-pass recirculation [type (inter., ext.)]		Internal		
Cooling system capacity	With heater—L(qt.)	15.04 (15.89)		
	With air cond.—L(qt.)	14.97 (15.82)		
	Opt. equipment [specify—L(qt.)]	15.69 (16.58)		
Water jackets full length of cyl. (yes, no)		Yes		
Water all around cylinder (yes, no)		Yes		
Water jackets open at head face (yes, no)				
Radiator core	Std., A/C, HD	Std.	A/C	H.D.
	Type (cross-flow, etc.)	Cross flow		
	Construction (fin & tube mechanical, braze, etc.)			
	Material, mass [kg (wgt, lbs.)]	copper-brass, high efficiency radiator		
	Width <u>27"</u>	668.0	668.0	668.0
	Height <u>17 1/2"</u>	429.7	429.7	429.7
	Thickness <u>1"</u>	25.0	25.0	40.2
	Fins per inch *	4.0	2.5	2.5
Radiator end tank material				
Fan	Std., elec., opt.	Std.		A/C
	Number of blades & type (flex. solid, material)	4, Steel, Solid		5, Alum., Solid
	Diameter & projected width	482.6		508.0
	Ratio (fan to crankshaft rev.)	1.096:1		1.25:1
	Fan cutout type	--		Clutch
	Drive type (direct, remote)	V-Belt		V-Belt
	RPM at idle (elec.)	--		--
	Motor rating (wattage) (elec.)	--		--
	Motor switch (type & location) (elec.)	--		--
	Switch point (temp., pressure) (elec.)	--		--
	Fan shroud (material)	Plastic		Plastic

* - Distance between top of fins

MVMA Specifications Form Passenger Car

Car Line CHEVROLET
Model Year 1987 Issued 6-86 Revised (•) _____

METRIC (U.S. Customary)

Engine Description/Carb.
Engine Code

5.0 Liter V8 (307 CID)
4-Bbl. Carburetor
RPO LV2

Engine - Cooling System

Coolant recovery system (std., opt., n.a.)		Standard	
Coolant fill location (rad., bottle)		Bottle	
Radiator cap relief valve pressure [kPa (psi)]		104 (15)	
Circulation thermostat	Type (choke, bypass)	Choke	
	Starts to open at °C (°F)	91 (195)	
Water pump	Type (centrifugal, other)	Centrifugal	
	GPM 1000 pump rpm	22 GPM	
	Number of pumps	One	
	Drive (V-belt, other)	V-belt	
	Bearing type	Ball	
	Impeller material		
Housing material			
By-pass recirculation [type (inter., ext.)]		External	
Cooling system capacity	With heater—L.(qt.)	See Below	
	With air cond.—L.(qt.)	See Below	
	Opt. equipment [specify—L.(qt.)]		
Water jackets full length of cyl. (yes, no)		Yes	
Water all around cylinder (yes, no)		Yes	
Water jackets open at head face (yes, no)			
Radiator core	Std., A/C, HD	Std., A/C, H.D.	
	Type (cross-flow, etc.)	Cross flow	
	Construction (fin & tube mechanical, braze, etc.)		
	Material, mass [kg (wtg. lbs.)]	Copper-brass, high efficiency radiator	
	Width	718.8	
	Height	429.7	
	Thickness	25.0	
Fins per inch *	2.5		
Radiator end tank material			
Fan	Std., elec., opt.	Std.	A/c
	Number of blades & type (flex, solid, material)	4-Steel, solid	5-Alum., solid
	Diameter & projected width	482.6 (19.0)	
	Ratio (fan to crankshaft rev.)	.85	1.4
	Fan cutout type	Spacer	Clutch
	Drive type (direct, remote)	V-Belt	
	RPM at idle (elec.)	--	
	Motor rating (wattage) (elec.)	--	
	Motor switch (type & location) (elec.)	--	
	Switch point (temp., pressure) (elec.)	--	
	Fan shroud (material)	Plastic	

LV2 - 14.8 (15.6) C41, 14.5 (15.3) C60/C65, 15.4 (16.3) V03, 15.2 (16.1) V08

* - Distance between top of fins.

MVMA Specifications Form Passenger Car

Car Line CHEVROLET
 Model Year 1987 Issued 6-86 Revised (*) 9-86

METRIC (U.S. Customary)

Engine Description/Carb.
Engine Code

4.3 Liter V6 (262 CID)
 Electronic Fuel Injection
 RPO LB4

Engine - Fuel System (See supplemental page for details of Fuel Injection, Supercharger, Turbocharger, etc. if used)

Induction type: carburetor, fuel injection system, etc.		Fuel Injection	
Manufacturer		--	
Carburetor	Choke (type)	None	
	Idle spd.-rpm (spec. neutral or drive and propane if used)	Manual	"
		Automatic	"
Idle A/F mix.		Preset - no adjustment provided	
Fuel injection	Point of injection (no.)	Throttle body	
	Constant, pulse, flow	Pulse	
	Control (electronic, mech.)	Electronic	
	System pressure [kPa (psi)]	--	
Intake manifold heat control (exhaust or water thermostatic or fixed)		Exhaust	
Air cleaner type	Standard	Replaceable paper element, single snorkel	
	Optional	Not Available	
Fuel pump	Type (elec. or mech.)	Electrical	
	Location (eng., tank)	Fuel Tank	
	Pressure range [kPa (psi)]	--	

Fuel Tank

Capacity (refill L (gallons))		93 (24.5)*cpe & sed; 83.3 (22.0) - s.w. (approximately)
Location (describe)		Underbody behind rear axle
Attachment		Two straps to underbody
Material & Mass (kg (weight lbs))		Steel 11.448 (25.2)
Filler pipe	Location & material	Center, Coupe and sedan; L.R. quarter panel - station wagon
	Connection to tank	Solder
Fuel line (material)		Steel
Fuel hose (material)		Elastomer hose
Return line (material)		Not Available
Vapor line (material)		Steel
Extended range tank	Opt., n.a.	Not Available
	Capacity [L (gallons)]	"
	Location & material	"
	Attachment	"
Auxiliary tank	Opt., n.a.	"
	Capacity [L (gallons)]	"
	Location & material	"
	Attachment	"
	Selector switch or valve	"
Separate fill		"

*95 (25.0) with 5.0 liter 4-bbl. V8 engine.

MVMA Specifications Form Passenger Car

Car Line CHEVROLET
 Model Year 1987 Issued 6-86 Revised (*) 9-86

METRIC (U.S. Customary)

Engine Description/Carb.
 Engine Code

5.0 Liter V8 (305 CID)
 4-Bbl. Carburetor
 RPO LG4

Engine - Fuel System (See supplemental page for details of Fuel Injection, Supercharger, Turbocharger, etc. if used)

Induction type: carburetor, fuel injection system, etc.		Carburetor	
Manufacturer		Rochester	
Carburetor	Choke (type)	Electric	
	Idle spd.-rpm (spec. neutral or drive and propane if used)	Manual	Not Available
		Automatic	500 RPM (Drive)
			--
Idle A/F mix.		Preset - no adjustment provided	
Fuel injection	Point of injection (no.)	--	
	Constant, pulse, flow	--	
	Control (electronic, mech.)	--	
	System pressure [kPa (psi)]	--	
Intake manifold heat control (exhaust or water thermostatic or fixed)		Exhaust	
Air cleaner type	Standard	Replaceable paper element, single snorkel	
	Optional	None	
Fuel pump	Type (elec. or mech.)	Mechanical	
	Location (eng., tank)	Lower - right front	
	Pressure range [kPa (psi)]	38.0-48.5 (5.5-7.0)	

Fuel Tank

Capacity (refill L (gallons))		95 (25.0) cpe & sed; 83.3 (22.0) - s.w. (approximately)
Location (describe)		Underbody behind rear axle
Attachment		Two straps to underbody
Material & Mass [kg (weight lbs)]		Steel 11.680 (25.7)
Filler pipe	Location & material	Rear - coupe and sedan; L.R. quarter panel - station wagon
	Connection to tank	Solder
Fuel line (material)		Steel
Fuel hose (material)		Rubber
Return line (material)		Steel
Vapor line (material)		Steel
Extended range tank	Opt., n.a.	Not Available
	Capacity [L (gallons)]	"
	Location & material	"
	Attachment	"
Auxiliary tank	Opt., n.a.	"
	Capacity [L (gallons)]	"
	Location & material	"
	Attachment	"
	Selector switch or valve	"
	Separate fill	"

MVMA Specifications Form Passenger Car

Car Line CHEVROLET
 Model Year 1987 Issued 6-86 Revised (•) 9-86

METRIC (U.S. Customary)

Engine Description/Carb.
 Engine Code

5.0 Liter V8 (307 CID)
 4-Bbl. Carburetor
 RPO LV2

Engine - Fuel System (See supplemental page for details of Fuel Injection, Supercharger, Turbocharger, etc. if used)

Induction type: carburetor, fuel injection system, etc.		Carburetor	
Manufacturer		Rochester	
Carburetor	Choke (type)	Electric	
	Idle spd.-rpm (spec. neutral or drive and propane if used)	Manual	Not Available
			--
		Automatic	--
Idle A/F mix.		Preset - no adjustment provided	
Fuel injection	Point of injection (no.)	--	
	Constant, pulse, flow	--	
	Control (electronic, mech.)	--	
	System pressure [kPa (psi)]	--	
Intake manifold heat control (exhaust or water thermostatic or fixed)		Exhaust	
Air cleaner type	Standard	Replaceable paper element, single snorkel	
	Optional	None	
Fuel pump	Type (elec. or mech.)	Mechanical	
	Location (eng., tank)	Right-Front engine	
	Pressure range [kPa (psi)]	41.37 - 51.71 (6.0 - 7.5)	

Fuel Tank

Capacity (refill L (gallons))		83.3 (22.0) wagon
Location (describe)		Left rear quarter
Attachment		Underbody strap
Material & Mass [kg (weight lbs)]		Steel 11.680 (25.7)
Filler pipe	Location & material	Left rear quarter
	Connection to tank	Solder
Fuel line (material)		Steel SAE #1008 or #1010
Fuel hose (material)		Rubber
Return line (material)		Steel SAE #1008 or #1010
Vapor line (material)		Steel SAE #1008 or #1010
Extended range tank	Opt., n.a.	Not Available
	Capacity [L (gallons)]	"
	Location & material	"
	Attachment	"
Auxiliary tank	Opt., n.a.	"
	Capacity [L (gallons)]	"
	Location & material	"
	Attachment	"
	Selector switch or valve	"
Separate fill		"

MVMA Specifications Form Passenger Car

METRIC (U.S. Customary)

Car Line CHEVROLET
Model Year 1987 Issued 6-86 Revised (e) 9-86

Engine Description/Carb.
Engine Code

4.3 Liter V6 (262 CID)
Electronic Fuel Injection
RPO LB4

Vehicle Emission Control

Exhaust Emission Control	Type (air injection, engine modifications, other)		Air injection w/computer command control
	Air Injection	Pump or pulse	Pump
		Driven by	V-Belt
		Air distribution (head, manifold, etc.)	Exhaust manifold and catalytic converter
		Point of entry	Exhaust manifold
	Exhaust Gas Recirculation	Type (controlled flow, open orifice, other)	--
		Exhaust source	--
		Point of exhaust injection (spacer, carburetor, manifold, other)	Inlet Manifold
	Catalytic Converter	Type	Dual bed ox & red
		Number of	One
Location(s)		Beneath RF underbody	
Volume [L (in ³)]		2.78 (170)	
Substrate type		Monolith	
Crankcase Emission Control	Type (ventilates to atmosphere, induction system, other)		Induction system
	Energy source (manifold vacuum, carburetor, other)		Manifold vacuum
	Discharges (to intake manifold, other)		Intake manifold
	Air inlet (breather cap, other)		Carburetor air cleaner
Evaporative Emission Control	Vapor vented to (crankcase, canister, other)	Fuel tank	Canister
		Carburetor	--
	Vapor storage provision		Canister
Electronic system	Closed loop (yes no)		Yes
	Open loop (yes no)		No

Engine - Exhaust System

Type (single, single with cross-over, dual, other)		Single	
★	Muffler no. & type (reverse flow, straight thru, separate resonator) Material & Mass [kg (weight lbs)]	One, Reverse flow	
	Resonator no. & type	None	
★	Exhaust pipe	Branch o.d., wall thickness	50.8 x 1.14 (2.0 x 0.04)
		Main o.d., wall thickness	57.15 x 1.40 (2.25 x 0.05)
		Material & Mass [kg (weight lbs)]	Stainless steel
★	Intermediate pipe	o.d. & wall thickness	57.15 x 1.40 (2.25 x 0.05)
		Material & Mass [kg (weight lbs)]	Steel tubing
★	Tail pipe	o.d. & wall thickness	50.8 x 1.10 (2.0 x 0.04)
		Material & Mass [kg (weight lbs)]	Aluminum coated steel 3.231 (7.1)

* Purchased as unit: 8.785 (19.4)

MVMA Specifications Form Passenger Car

Car Line CHEVROLET
 Model Year 1987 Issued 6-86 Revised (e) 9-86

METRIC (U.S. Customary)

Engine Description/Carb.
 Engine Code

5.0 Liter V8 (305 CID) 4-Bbl. Carburetor RPO LG4	5.0 Liter V8 (307 CID) 4-Bbl. Carburetor RPO LV2
--	--

Vehicle Emission Control

Exhaust Emission Control	Type (air injection, engine modifications, other)		Air injection w/ Computer Command Control
	Air Injection	Pump or pulse	Pump vane
		Driven by	V-Belt
		Air distribution (head, manifold, etc.)	Exh.manifold & cat.conv.
		Point of entry	Exh. manifold takedown
	Exhaust Gas Recirculation	Type (controlled flow, open orifice, other)	Pulse width, modulated
		Exhaust source	Manifold exhaust crossover
		Point of exhaust injection (spacer, carburetor, manifold, other)	Inlet manifold
	Catalytic Converter	Type	Dual bed (a)
		Number of	One
Location(s)		Beneath RF underbody	
Volume [L (in³)]		2.78 (169.8)	
Substrate type		Monolith	
Crankcase Emission Control	Type (ventilates to atmosphere, induction system, other)		Induction system
	Energy source (manifold vacuum, carburetor, other)		Manifold vacuum
	Discharges (to intake manifold, other)		Inlet manifold
	Air inlet (breather cap, other)		Carburetor air cleaner
Evaporative Emission Control	Vapor vented to (crankcase, canister, other)	Fuel tank	Canister
		Carburetor	Canister
	Vapor storage provision		Canister
Electronic system	Closed loop (yes/no)		Yes
	Open loop (yes/no)		No

Engine - Exhaust System

Type (single, single with cross-over, dual, other)		Single w/crossover
Muffler no. & type (reverse flow, straight thru, separate resonator) Material & Mass [kg (weight lbs)]		One, Reverse flow
Resonator no. & type		None
Exhaust pipe	Branch o.d., wall thickness	50.8x.86 (2.0x.034) (b)
	Main o.d., wall thickness	57.15x1.8 (2.25x.071) (c)
	Material & Mass [kg (weight lbs)]	(b) & (c)
Intermediate pipe	o.d. & wall thickness	63.5 x 1.4 (2.50 x .055) (d) 57.15 x 1.8 (2.25 x .071) (d)
	Material & Mass [kg (weight lbs)]	Steel tubing
Tail pipe	o.d. & wall thickness	63.5 x 1.4 (2.50 x .055) (d)
	Material & Mass [kg (weight lbs)]	Alum. coated steel tubing (e)

- (a) - Oxidizing and reducing.
- (b) - Laminated tubing - steel inner, stainless steel outer.
- (c) - Stainless steel tubing.
- (d) - Aluminum coated steel.
- (e) - LG4 4.536 (10.0), LV2 3.231 (7.1)
- * - Purchased as unit LG4 9.072 (20.0), LV2 7.439 (16.4)

MVMA Specifications Form Passenger Car

Car Line CHEVROLET
 Model Year 1987 Issued 6-86 Revised (●) _____

METRIC (U.S. Customary)

Engine Description/Carb.
 Engine Code

4.3L V6 262 CID RPO LB4	5.0L V8 305 CID RPO LG4	5.0L V8 307 CID RPO LV2
-------------------------------	-------------------------------	-------------------------------

Transmissions/Transaxle

Manual 3-speed (std., opt., n.a.) (mfr.)	Not available
Manual 4-speed (std., opt., n.a.) (mfr.)	Not available
Manual 5-speed (std., opt., n.a.) (mfr.)	Not available
Manual overdrive (std., opt., n.a.) (mfr.)	Not available
Automatic (std., opt., n.a.) (mfr.)	Standard
Automatic overdrive (std., opt., n.a.) (mfr.)	Standard

Manual Transmission/Transaxle

Number of forward speeds			
Transmission ratios	In first		
	In second	Not	
	In third	Available	
	In fourth		
	In fifth		
	In overdrive		
	In reverse		
Synchronous meshing (specify gears)			
Shift lever location			
Lubricant	Capacity [L (pt.)]		
	Type recommended		
	SAE viscosity number	Summer	
		Winter	
Extreme cold			

Clutch (Manual Transmission)

Make, type, engagement (describe) – (hydraulic, cable, rod)		
Assist (yes, no / percent)		
Type pressure plate springs		Not
Total spring load [N (lb.)]		Available
No. of clutch driven discs		
Clutch facing	Material	
	Manufacturer	
	Part number	
	Rivets-plate	
	Rivet size	
	Outside & inside dia.	
	Total eff. area [cm ² (in. ²)]	
	Thickness	
Engagement cushion method		
Release bearing	Type & method of lubrication	
Torsional damping	Method: springs, friction material	

MVMA Specifications Form Passenger Car

Car Line CHEVROLET
 Model Year 1987 Issued 6-86 Revised (●) 9-86

METRIC (U.S. Customary)

Engine Description/Carb.
 Engine Code

4.3 Liter V6 (262 CID)
 Electronic Fuel Injection
 RPO LB4

Automatic Transmission/Transaxle

Trade name		3-Speed Automatic
Type and special features (describe)		Torque converter with planetary gears '200c'
Selector	Location	Steering column
	Ltr./No. designation	P-R-N-D-2-1
Gear ratios	1st	2.74
	2nd	1.57
	3rd	1.00*
	4th	Not Available
	Reverse	2.07
Max. upshift speed - drive range [km/h (mph)]		1-2=69(43), 2-3=113(70)
Max. kickdown speed - drive range [km/h (mph)]		3-2=107(66.5), 2-1=60 (37)
Min. overdrive speed [km/h (mph)]		Not Applicable
Torque converter	Number of elements	3
	Max. ratio at stall	1.91:1
	Type of cooling (air, liquid)	Liquid
	Nominal diameter	298 (11.75)
Lubricant	Capacity [refill L (pt.)]	3.0 (6.0)
	Type Recommended	Dexron II
Oil cooler (std., opt., NA, internal, external, air, liquid)		Standard, integral with radiator *Converter Clutch engagement

Axle or Front Wheel Drive Unit

Type (front, rear)		Rear	
Description		Semi-floating axle, overhung hypoid drive pinion and ring gear	
Limited slip differential (type)		Disc clutch	
Drive pinion offset		7.5" R.G.-38.1 (1.50); 8.50" R.G.-44 (1.75)	
Drive pinion (type)		Hypoid gear	
No. of differential pinions		Two	
Pinion / differential adjustment (shim, other)		Shim	
Pinion / differential bearing adjustment (shim, other)		Collapsible Sleeve	
Driving wheel bearing (type)		Direct or Single Row Cylindrical	
Lubricant	Capacity [L (pt.)]	7.5" R.G.-1.6 (3.5); 8.50" R.G. 2.0 (4.3)	
	Type recommended	GL-5 Gear Lubricant	
	SAE viscosity number	Summer	80W or 80W-90
		Winter	80W or 80W-90
Extreme cold		80W or 80W-90	

Axle or Transaxle Ratio and Tooth Combinations (See 'Power Teams' for axle ratio usage.)

Axle ratio (or overall top gear ratio)		2.56	3.08
No. of teeth	Pinion	16	13
	Ring gear or gear	41	40
Ring gear o.d.		191 (7.50)	216 (8.50)
Transaxle	Transfer gear ratio	--	--
	Final drive ratio	--	--

MVMA Specifications Form Passenger Car

Car Line CHEVROLET
Model Year 1987 Issued 6-86 Revised (*) 9-86

METRIC (U.S. Customary)

Engine Description/Carb.
Engine Code

5.0 Liter V8 (305 CID)
4-Bbl. Carburetor
RPO LG4

Automatic Transmission/Transaxle (See Power Teams for transmission usage)

Trade name		4-Speed Automatic	
Type and special features (describe)		Torque converter with planetary gears '700-R4 '200-4R'	
Selector	Location	Steering column	
	Ltr./No. designation	P-R-N- D -D-2-1	
Gear ratios	1st	3.06	2.74
	2nd	1.63*	1.57
	3rd	1.00*	1.00*
	4th	0.70*	0.67*
	Reverse	2.29	2.07
Max. upshift speed - drive range [km/h (mph)]		1-2=60(37.5), 2-3=(108(67))	Not Avail.
Max. kickdown speed - drive range [km/h (mph)]		3-2=100(62), 2-1=45(28)	"
Min. overdrive speed [km/h (mph)]		67 (41.5)	"
Torque converter	Number of elements	3	
	Max. ratio at stall	5.8:1	Not Available
	Type of cooling (air, liquid)	Liquid	
	Nominal diameter	298 (11.75)	
Lubricant	Capacity (refill L (pt.))	3.0 (6.0)	
	Type Recommended	Dexron II	
Oil cooler (std., opt., NA, internal, external, air, liquid)		Standard, integral with radiator	

Axle or Front Wheel Drive Unit

Type (front, rear)		Rear		
Description		Semi-floating axle, overhung hypoid drive pinion and ring gear		
Limited slip differential (type)		Disc clutch		
Drive pinion offset		7.5" R.G.-38.1 (1.50); 8.50" R.G.-44 (1.75)		
Drive pinion (type)		Hypoid gear		
No. of differential pinions		Two		
Pinion / differential adjustment (shim, other)		Shim		
Pinion / differential bearing adjustment (shim, other)		Collapsible Sleeve		
Driving wheel bearing (type)		Direct or Single Row Cylindrical		
Lubricant	Capacity [L (pt.)]	7.5" R.G.-1.6 (3.5); 8.50" R.G. 2.0 (5.4)		
	Type recommended	GL-5 Gear Lubricant		
	SAE viscosity number	Summer	80W or 80W-90	
		Winter	80W or 80W-90	
Extreme cold		80W or 80W-90		

Axle or Transaxle Ratio and Tooth Combinations (See 'Power Teams' for axle ratio usage.)

Axle ratio (or overall top gear ratio)		2.73	3.08	2.56
No. of teeth	Pinion	15	13	16
	Ring gear or gear	41	40	41
Ring gear o.d.		191(7.50)(b)	216(8.50)	191(7.50)
Transaxle	Transfer gear ratio			
	Final drive ratio			

* - Converter clutch engagement
(b) - Limited slip wagon - 216 (8.50)

MVMA Specifications Form Passenger Car

Car Line CHEVROLET
 Model Year 1987 Issued 6-86 Revised (*) 9-86

METRIC (U.S. Customary)

Engine Description/Carb.
 Engine Code

5.0 Liter V8 (307 CID)
 4-8bl. Carburetor
 RPO LV2

Automatic Transmission/Transaxle (See Power Teams for transmission usage)

Trade name		4-Speed Automatic
Type and special features (describe)		Torque converter with planetary gears 200-4R
Selector	Location	Steering column
	Ltr./No. designation	P-R-N- D -0-2-1
Gear ratios	1st	2.74
	2nd	1.57
	3rd	1.00*
	4th	0.67*
	Reverse	2.07
Max. upshift speed - drive range [km/h (mph)]		72 (35), 129 (60)
Max. kickdown speed - drive range [km/h (mph)]		56 (29), 124 (57), 136 (85)
Min. overdrive speed [km/h (mph)]		28
Torque converter	Number of elements	Three
	Max. ratio at stall	1.9
	Type of cooling (air, liquid)	Liquid
	Nominal diameter	298.5 (11.75)
Lubricant	Capacity (refill L (pt.))	5L
	Type Recommended	Dextron II
Oil cooler (std., opt., NA, internal, external, air, liquid)		Standard, integral with radiator

Axle or Front Wheel Drive Unit

Type (front, rear)		Rear	
Description		Semi-floating axle, overhung hypoid drive pinion and ring gear	
Limited slip differential (type)		Disc clutch	
Drive pinion offset		8.50" R.G. - 44.0 (1.75)	
Drive pinion (type)		Hypoid gear	
No. of differential pinions		Two	
Pinion / differential adjustment (shim, other)		Shim	
Pinion / differential bearing adjustment (shim, other)		Collapsible sleeve	
Driving wheel bearing (type)		Direct or single row cylindrical	
Lubricant	Capacity [L (pt.)]	8.50" R.G. 2.0 (5.4)	
	Type recommended	GL-5 gear lubricant	
	SAE viscosity number	Summer	80W or 80W-90
		Winter	80W or 80W-90
		Extreme cold	80W or 80W-90

Axle or Transaxle Ratio and Tooth Combinations (See 'Power Teams' for axle ratio usage.)

Axle ratio (or overall top gear ratio)		2.73 (Std.)	3.08 (Opt.)	3.23 (Opt.)
No. of teeth	Pinion	15	13	13
	Ring gear or gear	41	40	42
Ring gear o.d.		8.50	8.50	8.50
Transaxle	Transfer gear ratio			
	Final drive ratio			

* - Converter clutch engagement

MVMA Specifications Form
Passenger Car
METRIC (U.S. Customary)

Car Line CHEVROLET
 Model Year 1987 Issued 6-86 Revised (•) _____

Engine Description/Carb.
 Engine Code

4.3 Liter V6 (262 CID)
 Electronic Fuel Injection
 RPO LB4

Propeller Shaft – Rear Wheel Drive

Manufacturer Type (straight tube, tube-in-tube, internal-external damper, etc.)		Straight tube	
Outer diam. x length* x wall thickness	Manual 3-speed trans.	Not Available	
	Manual 4-speed trans.	"	
	Manual 5-speed trans.	"	
	Overdrive	"	
	Automatic transmission	(3), (4)	
Inter- mediate bearing	Type (plain, anti-friction)	None	
	Lubrication (fitting, prepack)	--	
Slip yoke	Type	Splined	
	Number of teeth	27	
	Spline o.d.	29.858-29.883 (1.1755-1.1765)	
Universal joints	Make and mfg. no.	Front	Saginaw 44
		Rear	Saginaw 44
	Number used	Two	
	Type (ball and trunnion, cross)	Cross	
	Rear attach (u-bolt, clamp, etc.)	Strap & bolt	
	Bearing	Type (plain, anti-friction)	Anti-friction
Lubrication (fitting, prepack)		Prepacked	
Drive taken through (torque tube, arms or springs)		Control arm	
Torque taken through (torque tube, arms or springs)		Torque tube	

* Centerline to centerline of universal joints, or to centerline of rear attachment.

- 76.2x1384.0x1.65mm (3.0x54.49x.065 in) 3.08 axle with and w/o limited slip differential.
- 69.9x1484.9x1.65-Sedans & Coupes without limited slip differential.
- 76.2x1464.3x1.65-Sedans & Coupes with limited slip differential.

MVMA Specifications Form Passenger Car

Car Line CHEVROLET
 Model Year 1987 Issued 6-86 Revised (e) _____

METRIC (U.S. Customary)

Engine Description/Carb.
 Engine Code

5.0 Liter V8 (305 CID)
 4-Bbl. Carburetor
 RPO LG4

Propeller Shaft – Rear Wheel Drive

Manufacturer Type (straight tube, tube-in-tube, internal-external damper, etc.)		Straight tube	
Outer diam. x length* x wall thickness	Manual 3-speed trans.	Not Available	
	Manual 4-speed trans.	"	
	Manual 5-speed trans.	"	
	Overdrive	"	
	Automatic transmission	(3)	(4)
Inter- mediate bearing	Type (plain, anti-friction)	None	
	Lubrication (fitting, prepack)	--	
Slip yoke	Type	Splined	
	Number of teeth	27	
	Spline o.d.	29.858-29.883 (1.1755-1.1765)	
Universal joints	Make and mfg. no.	Front	Saginaw 44
		Rear	Saginaw 44
	Number used	Two	
	Type (ball and trunnion, cross)	Cross	
	Rear attach (u-bolt, clamp, etc.)	Strap & Bolt	
	Bearing	Type (plain, anti-friction)	Anti-Friction
Lubrication (fitting, prepack)		Prepacked	
Drive taken through (torque tube, arms or springs)		Control Arm	
Torque taken through (torque tube, arms or springs)		Control Arm	

- (3) 76.2x1410.7x1.65mm (3.0x55.45x.065 in) 2.73 axle without Limited Slip Differential.
 76.2x1384.0x1.65mm (3.0x54.49x.065 in) 2.73 axle with Limited Slip Differential.
 * Centerline to centerline of universal joints, or to centerline of rear attachment.
 3.08 axle with and w/o Limited Slip Differential.
 All Station Wagons.
- (4) 69.9x1484.9x1.65 - Sedan & Coupe without Limited Slip.
 76.2x1464.3x1.65 - Sedan & Coupe with Limited Slip.
 - All Station Wagons.

MVMA Specifications Form Passenger Car

Car Line CHEVROLET
 Model Year 1987 Issued 6-86 Revised (•) _____

METRIC (U.S. Customary)

Engine Description/Carb.
 Engine Code

5.0 Liter V8 (307 CID)
 4-Bbl. Caruburetor
 RPO LV2

Propeller Shaft – Rear Wheel Drive

Manufacturer Type (straight tube, tube-in-tube, internal-external damper, etc.)		Straight tube	
Outer diam. x length* x wall thickness	Manual 3-speed trans.	Not Available	
	Manual 4-speed trans.	"	
	Manual 5-speed trans.	"	
	Overdrive	"	
	Automatic transmission	69.85x1485x1.64 76.20x1464x1.64 82.55x1485x1.64 (2.75x58.46x.065) (3.00x57.65x.065) (3.25x58.46x.065)	
Inter- mediate bearing	Type (plain, anti-friction)	None	
	Lubrication (fitting, prepack)	None	
Slip yoke	Type	Splined	
	Number of teeth	27	
	Spline o.d.	1.175	
Universal joints	Make and mfg. no.	Front	Saginaw Steerin Gear
		Rear	Saginaw Steering Gear
	Number used	Two	
	Type (ball and trunnion, cross)	Cross	
	Rear attach (u-bolt, clamp, etc.)	Strap & Bolt	
	Bearing	Type (plain, anti-friction)	Anti-Friction
Lubrication (fitting, prepack)		Prepacked	
Drive taken through (torque tube, arms or springs)		Control Arm	
Torque taken through (torque tube, arms or springs)		Control Arm	

* Centerline to centerline of universal joints, or to centerline of rear attachment.

MVMA Specifications Form Passenger Car

Car Line CHEVROLET
 Model Year 1987 Issued 6-86 Revised (•) 9-86

METRIC (U.S. Customary)

Body Type And/Or
Engine Displacement

Sedans & Coupe	Station Wagon
----------------	---------------

Suspension - General

Car leveling	Std./opt./n.a.	Not Available	Optional (rear only)
	Type (air, hyd., etc.)	Not Available	Air
	Manual/auto. controlled	Not Available	Manual
Provision for brake dip control		Front suspension geometry	
Provision for accel. squat control		Rear suspension geometry	
Provisions for car jacking		Side lift frame jack body bolt access holes on each side of frame about 2 feet from each wheel centerline	
Shock absorber (front & rear)	Type	Direct, double acting, hydraulic	
	Make	Delco	
	Piston diameter	25 (1.0)	
	Rod diameter	13.49 (0.53)	

Suspension - Front

Type and description		Independent - SLA	
Travel	Full jounce	90.3mm (3.56 in)	
	Full rebound	197.7mm (4.24 in)	
Spring	Type (coil, leaf, other) & material	Coil-Steel Alloy	
	Insulators (type & material)	Ring Type Natural Rubber	
	Size (coil design height & i.d., bar length x dia.)	241.3x102.9x3347.15.8 (9.5x4.05x131.7x0.622)	241.3x102.9x2762.2x16.1 (9.5x4.05x108.7x0.634)
	Spring rate [N/mm (lb./in.)]	V6-47.0(268.0) V8-52.5(300.0)	
	Rate at wheel [N/mm (lb./in.)]	V6-14.4(82.3), V8-15.8(90.3)	
Stabilizer	Type (link, linkless, frameless)	Link	
	Material & bar diameter	Tubular Steel-28(1.1);29(1.14)(a) Steel-28 (1.1)	

Suspension - Rear

Type and description		Salisbury 4-link	
Travel	Full jounce	123.0mm (4.8 in)	101mm (3.98 in)
	Full rebound	114.0mm (4.5 in)	112mm (4.41 in)
Spring	Type (coil, leaf, other) & material	Coil-Steel Alloy	
	Size (length x width, coil design height & i.d., bar length & dia.)	254x139.7x2961.3x13.44 (10.0x5.5x116.6x0.529)	254x139.7x2585.7x15.5 (10.0x5.5x101.8x0.609)
	Spring rate [N/mm (lb./in.)]	17.5(100.0), w/F40&41-27.1(155.0)	
	Rate at wheel [N/mm (lb./in.)]	19.4(110.0), w/F40&41-27.2(155.0)	
	Insulators (type & material)	Ring Type Butyl Rubber	
If leaf	No. of leaves	--	
	Shackle (comp. or tens.)	--	
Stabilizer	Type (link, linkless, frameless)	Linkless (a)	None
	Material & bar diameter	Steel - 25 (1.0)	--
Track bar (type)		None	

(a) Used with RPO F41 sport suspension

MVMA Specifications Form
Passenger Car
METRIC (U.S. Customary)

Car Line CHEVROLET
 Model Year 1987 Issued 6-86 Revised (e) _____

Body Type And/Or
 Engine Displacement

Sedans & Coupe	Station Wagon
----------------	---------------

Brakes - Service

Description		Single caliper disc front, duo-servo drum rear.			
Manufacturer and brake type (std., opt., n.a.)	Front (disc or drum)	Disc			
	Rear (disc or drum)	Drum			
Self-adjusting (std., opt., n.a.)		Standard			
Special valving	Type (proportion, delay, metering, other)	Metering and Proportioning			
Power brake (std., opt., n.a.)		Standard			
Booster type (remote, integral, vac., hyd., etc.)		Integral low - vacuum warning switch	Electric (a)		
Vacuum source (inline, pump, etc.)		Inline (Intake Manifold)	--		
Vacuum reservoir (volume in. ³)		--	--		
Vacuum pump-type (elec, gear driven, belt driven, if other so state)		--	--		
Anti-lock device type (std., opt., n.a.) (F/R)		Not Available			
Effective area [cm ² (in. ²)]*		648 (100.5)	717 (111.1)		
Gross lining area [cm ² (in. ²)]**(F/R)		717 (111.1)	792 (122.9)		
Swept area [cm ² (in. ²)]**(F/R)		2127 (329.8)	2420 (375.1)		
Rotor	Outerworking diameter	F/R	279.1 (11.0)/--		
	Inner working diameter	F/R	177.8 (7.0)/--		
	Thickness	F/R	26.2 (1.03)/--		
	Material & type (vented solid)	F/R	Cast Iron, Vented/--		
Drum	Diameter & width	F/R	--/241.3 (9.5)/V8-279 (11.0) --/279.4 (11.0)		
	Type and material	F/R	--/Cast Iron Finned		
Wheel cylinder bore			74.7 (2.94)/22.22 (.875) 74.7 (2.94)/25.0 (.98)		
Master cylinder	Bore stroke	F/R	28.6 (1.13)/39.6 (1.56)(b) 31.75 (1.25)		
Pedal arc ratio			3.5:1 4.23:1		
Line pressure at 445 N(100 lb.) pedal load [kPa (psi)]			--		
Lining clearance		F/R	Self-adjusting/Self-adjusting		
Brake lining	Front wheel	Bonded or riveted (rivets seg.)		Riveted; 8	
		Rivet size		5.33 x 9.12 (.210 x .359)	
		Manufacturer		Delco Moraine	
		Lining code*****			
		Material		Semi-metallic 7161A	
		****	Primary or out-board	137 x 48.8 x 11.81 (5.40 x 1.92 x 0.465)	
		Size	Secondary or in-board	137 x 48.8 x 11.81 (5.40 x 1.92 x 0.465)	
	Shoe thickness (no lining)		Inboard 15.75 (.620); Outboard 14.0 (.550)		
	Rear wheel	Bonded or riveted (rivets/seg.)		Riveted; 10-primary, 12-secondary	
		Manufacturer		Inland	
		Lining Code*****		PRIM/SEC 224FF/235FE	
		Material		PRIM/SEC Organic 4035/4050	
		****	Primary or out-board	192.5x50.8x4.98 (7.58x2.0x.196) 225x50.8x5.6 (8.86x2.0x0.22)	
		Size	Secondary or in-board	249.7x50.8x6.73 (9.83x2.0x.265) 291.0x50.8x6.6(11.5x2.0x0.26)	
Shoe thickness (no lining)		Prim-7.6(.301); Sec-9.4(.370) Prim 8.3(.330); Sec-9.1(.370)			

*Excludes rivet holes, grooves, chamfers, etc.

**Includes rivet holes, grooves, chamfers, etc.

***Total swept area for four brakes. (Drum brake: Widest lining contact width for each brake x its contact circumference.)
 (Disc brake: Square of Outer Working Dia. minus Square of inner Working Dia. multiplied by Pi/2 for each brake.)

****Size for drum brakes includes length x width x thickness.

*****Manufacturer I.D., catalog or formulation designation and coefficient of friction classification.

(a) Electro-hydraulic booster on wagons. (b) V8 engine 23.8 (.934)

MVMA Specifications Form Passenger Car

Car Line CHEVROLET
 Model Year 1987 Issued 6-86 Revised (e) _____

METRIC (U.S. Customary)

Body Type And/Or
Engine Displacement

Sedans & Coupe	Station Wagon
----------------	---------------

Tires And Wheels (Standard)

Tires	Size (load range, ply)	P205/75R15 (B/W*)		P225/75R15 (B/W*)		
	Type (bias, radial, etc.)	Steel belted radial				
	Inflation pressure (cold) for recommended max. vehicle load	Front (kPa (psi))	240 (35)		205 (30)	
		Rear (kPa (psi))	240 (35)		240 (35)	
	Rev./mile—at 70 km/h (45 mph)	478		458		
Wheels	Type & material	Short spoke disc, steel				
	Rim (size & flange type)	15 x 6		15 x 7		
	Wheel offset	5.08-8.13 (0.20-0.32)		7.5 (0.30)		
	Attachment	Type (bolt or stud)	Stud			
		Circle diameter	120.6 (4.75)		127.0 (5.00)	
Number & size		5-7/16-20 UNF-2B hex nuts		5-1/2-20 UNF-2B hex nuts		
Spare	Tire and wheel (same, if other describe)	16x4 compact spare, T125/80D16 (without positraction) 16x4 compact spare, T145/80D16 (with Positraction and wagons)				
	Storage position & location (describe)	Sedans—horizontal front center of trunk compartment. Station wagon, vertical right rear quarter panel.				

Tires And Wheels (Optional) *Tires are "All Season" mud and snow, 4th generation, GM TPG tires

Size (load range, ply)	P205/75R15 (W/W*,+)	P225/75R15(W/W*,+)
Type (bias, radial, etc.)	Steel belted radial	Steel belted radial
Wheel (type & material)	Short spoke disc, steel	Short spoke disc, steel
Rim (size, flange type and offset)	15x6, Opt. 15x7, 5.0, 8.13(0.20-0.32)	15x7, 7.5 (0.30)
Size (load range, ply)		
Type (bias, radial, etc.)		
Wheel (type & material)		
Rim (size, flange type and offset)	P225/70R15 (w/w) (*,+)(a)	
Size (load range, ply)	Steel belted radial	
Type (bias, radial, etc.)	Short spoke disc, steel	
Wheel (type & material)	15x7; 5.08-8.13 (0.20-0.32)	
Rim (size, flange type and offset)		
Size (load range, ply)		
Type (bias, radial, etc.)		
Wheel (type & material)		
Rim (size, flange type and offset)		
Spare tire and wheel (if configuration is different than road tire or wheel, describe optional spare tire and/or wheel location & storage position)		

(+)-Sealant tire option available with w/w tire.
 (a)-Requires performance handling package, RPO F41.

Brakes - Parking

Type of control	Foot pedal application; "T" Handle release	
Location of control	Under instrument panel; left of steering column	
Operates on	Rear service brakes	
If separate from service brakes	Type (internal or external)	--
	Drum diameter	--
	Lining size (length x width x thickness)	--

MVMA Specifications Form Passenger Car

Car Line CHEVROLET
 Model Year 1987 Issued 6-86 Revised (•) _____

METRIC (U.S. Customary)

Body Type And/Or Engine Displacement	Sedans & Coupe	Station Wagon
--------------------------------------	----------------	---------------

Steering

Manual (std., opt., n.a.)		Not available		
Power (std., opt., n.a.)		Standard and includes quick prime feature		
Adjustable steering wheel/column (tilt, telescope, other)	Type	Tilt-universal jointed strg. shaft at base of strg. whl. 6 posn.		
	Manufacturer			
	(Std., opt., n.a.)	Optional		
Wheel diameter** (W9) SAE J1100	Manual	Not Available		
	Power	387 (15.25)		
Turning diameter m (ft.)	Outside front	Wall to wall (l. & r.)	13.6 (44.6) 13.8 (45.3)	
		Curb to curb (l. & r.)	11.8 (38.7) 12.1 (39.7)	
	Inside rear	Wall to wall (l. & r.)	Not Available	
		Curb to curb (l. & r.)	"	
Scrub Radius*		"		
Manual	Gear	Type	Not Available	
		Manufacturer	"	
		Ratios	"	
	No. wheel turns (stop to stop)	Gear	"	
		Overall	"	
Power	Type (coaxial, linkage, etc.)		Integral gear with power piston & vane type pump	
	Manufacturer		Saginaw Steering Gear	
	Gear	Type	Semi-reversible recirculating ball nut	
		Ratios	Gear	14:1 (a) 13/16:1 (b)
			Overall	16.5 (a) 18.8:1 on center (b)
	Pump (drive)		'V' belt	
No. wheel turns (stop to stop)		3.16	3.3	
Linkage	Type		Parallelogram	
	Location (front or rear of wheels, other)		Front	
	Tie rods (one or two)		Two	
Steering axis	Inclination at camber (deg.)		9.785 @1	
	Bearings (type)	Upper	Ball stud with non-metallic surfaces	
		Lower	Ball stud with non-metallic surfaces	
		Thrust	None	
Steering spindle & joint type		"		
Wheel spindle/hub	Diameter	Inner bearing	31.7 (1.25)	
		Outer bearing	19.0 (0.75)	
	Thread (size)		3/4-20	
	Bearing (type)		Tapered roller	

*The horizontal distance in the front elevation between wheel centerline and kingpin (ball joint) axis at ground.

**See Page 21.

- (a) V8 sedans and coupes
- (b) V6 sedans and coupes, V8 wagons

MVMA Specifications Form Passenger Car

Car Line CHEVROLET
Model Year 1987 Issued 6-86 Revised (•) _____

METRIC (U.S. Customary)

Body Type And/Or
Engine Displacement

Sedans & Coupe	Station Wagon
----------------	---------------

Wheel Alignment

Wheel Location	Service	Alignment	
		Parameter	Specification
Front wheel at curb mass (wt.)	Service checking	Caster (deg.)	+2° to +4°
		Camber (deg.)	0° to +1.6°
		Toe-in (outside track-mm (in.))	+0.5° to +0.25° (1/16" to +1/4")
	Service reset*	Caster	+3° +/- 0.5°
		Camber	+0.8° +/- 0.5°
		Toe-in	+ .15 +/- .05° (+1/8" +/- 1/16")
	Periodic M.V. inspection	Caster	+1° to +5°
		Camber	-0.7° to +2.3°
		Toe-in	-0.15° to +0.55° (-3/16" to +9/16")
Rear wheel at curb mass (wt.)	Service checking	Camber (deg.)	Not Applicable
		Toe-in (outside track-mm (in.))	"
	Service reset*	Camber	"
		Toe-in	"
	Periodic M.V. inspection	Camber	"
		Toe-in	"

* Indicates pre-set, adjustable, trend set or other.

Electrical - Instruments and Equipment

Speedometer	Type (analog, digital, std., opt.)	Rectangular dial with pointer (A)
	Trip odometer (std., opt., n.a.)	Optional (A)
EGR maintenance indicator		Not Available
Charge indicator	Type	Tell-Tale warning light
	Warning device (light, audible)	Not Available
Temperature indicator	Type	Tell-Tale warning light (A)
	Warning device (light, audible)	Not Available
Oil pressure indicator	Type	Tell-Tale warning light
	Warning device (light, audible)	Not Available
Fuel indicator	Type	Electric gauge, pointer gauge
	Warning device (light, audible)	Not Available
Windshield wiper	Type (standard)	Electric, two-speed
	Type (optional)	Intermittent control type
	Blade length	457.2 (18.0 in)
	Swept area (cm ² (in. ²))	6107 (946.8 in ²)
Windshield washer	Type (standard)	Push button* fluidic nozzle
	Type (optional)	Not Available
	Fluid level indicator (light, audible)	"
Rear window wiper, wiper/washer (std., opt., n.a.)		Not Available
Horn	Type	Vibrator
	Number used	Dual-1BNO0 models: one (low note) on 1BLO0 models
Other		Restraint system warning light and buzzer. Parking brake and brake failure warning light. "Tailgate ajar" lamp for station wagon. "Headlamp-on" chime for 1BNO0 models.

(A) Optional gage package includes circular speedometer, trip odometer, coolant temperature gage, and fuel economy (vacuum) gage.

(B) Buzzer for 1BLO0, Chime for 1BNO0.

MVMA Specifications Form Passenger Car

Car Line CHEVROLET
 Model Year 1987 Issued 6-86 Revised (e) _____

METRIC (U.S. Customary)

Engine Description/Carb. Engine Code	4.3L V6	5.0L V8
	262 CID	305 CID
	RPO LB4	RPO LG4

Electrical – Supply System

Battery	Manufacturer	Delco Remy	
	Model, std., (opt.)	75-630	70-525 Base, 75-570 H.D.
	Voltage	12 Volts	
	Amps at 0°F cold crank	630	525 Base, 570 H.D.
	Minutes-reserve capacity	90	75 Base, 90 H.D.
	Amp/hrs. - 20 hr. rate	--	
	Location	Engine Compartment	
Alternator	Manufacturer	Delco Remy	
	Rating	56	56
	Ratio (alt. crank/rev.)	2.36:1	
	Optional (type & rating)	None	
Regulator	Type	Micro circuit units, integral with alternator	

Electrical – Starting System

Start, motor	Current drain at 0°F		420 @ -20°F
Motor drive	Engagement type	Positive shift solenoid	
	Pinion engages from (front, rear)		Rear

Electrical – Ignition System

Type	Electronic (std., opt., n.a.)	--		
	Other (specify)	High Energy Ignition, (H.E.I.)		
Coil	Make	Delco Remy		
	Model	Integral with distributor		
	Current	Engine stopped - A	--	
		Engine idling - A	--	
Spark plug	Make	AC		
	Model	R43TS	R43TS	
	Thread (mm)	14 x 1.25		
	Tightening torque (N·m (lb. ft))	9-20 (7-15)		
	Gap	0.81 (.035)	0.81 (0.035)	
	Number per cylinder	One		
Distributor	Make	Delco Remy		
	Model	1103460		

Electrical – Suppression

Locations & type	Internal alternator capacitor, non-metallic high-tension ignition cables, resistor spark plugs, ignition coil by-pass capacitor, internal AC blower motor by-pass capacitor & A/C compression diode, with radio provisions; hood grounding clip, engine to dash panel ground strap, fuse block capacitor and on "heater only" blower motors and coax capacitor.
------------------	---

MVMA Specifications Form Passenger Car

Car Line CHEVROLET
Model Year 1987 Issued 6-86 Revised (e) _____

METRIC (U.S. Customary)

Engine Description/Carb.
Engine Code

5.0L
(307) V8
RPO LV2

Electrical - Supply System

Battery	Manufacturer	Delco Remy
	Model, std., (opt.)	Std. - Freedom Battery
	Voltage	12 Volts
	Amps at 0°F cold crank	525 Base, 570 H.D.
	Minutes-reserve capacity	75 Base, 90 H.D.
	Amp/hrs. - 20 hr. rate	54
Alternator	Location	Engine Compartment
	Manufacturer	Delco Remy
	Rating	78 Amp
	Ratio (alt. crank/rev.)	3.44
Regulator	Optional (type & rating)	None
	Type	Micro circuit units, integral with alternator

Electrical - Starting System

Start, motor	Current drain at 0°F	325 Amps @ -20°F
Motor drive	Engagement type	Positive
	Pinion engages from (front, rear)	Front

Electrical - Ignition System

Type	Electronic (std., opt., n.a.)	Std.	
	Other (specify)	High Energy Ignition	
Coil	Make	Delco Remy	
	Model	Integral with distributor	
	Current	Engine stopped - A	0-Amp
		Engine idling - A	1-Amp
Spark plug	Make	AC Division	
	Model	FR3LS6	
	Thread (mm)	14 mm	
	Tightening torque (N·m (lb, ft))	40 (30)	
	Gap	.060	
	Number per cylinder	One	
Distributor	Make	Delco Remy	
	Model	1103602	

Electrical - Suppression

Locations & type Internal alternator capacitor, non-metallic high-tension cables, resistor spark plugs, ignition coil by-pass capacitor, internal AC blower motor bypass capacitor & A/C compression diode, engine to dash panel ground strap, fuse block capacitor and on "heater only" blower motors and coax capacitor.

MVMA Specifications Form
Passenger Car
METRIC (U.S. Customary)

Car Line CHEVROLET
 Model Year 1987 Issued 6-86 Revised (●) _____

Body Type	4-Door Sedans 1BL69-1BN69-1BU69	2-Door Coupe 1BN47	4-Door Station Wagon 1BL35-1BN35
------------------	------------------------------------	-----------------------	-------------------------------------

Body

Structure	All-welded heavy-gage steel body. Full perimeter frame.
Bumper system front - rear	Steel bumper with reinforcing beam. Dual enersorbers. Bumper rub strips standard on Caprice Classic coupe and sedan, wagon, and Brougham. Optional caprice models.
Anti-corrosion treatment	Zinc-rich precoated steel is used in many critical areas, splash areas treated with zinc-rich primers and special waxes. Hot-melt materials used for sealing. Bodies are submersed in zinc phosphate rustproofing process before final elpo-coating dip.

Body - Miscellaneous Information

Type of finish (lacquer, enamel, other)	Lacquer	
Hood	Hinge location (front, rear)	Rear
	Type (counterbalance, prop)	4-Link type with spiral spring
	Release control (internal, external)	Internal
Trunk lid	Type (counterbalance, other)	Counterbalance
	Internal release control (elec., mech., n.a.)	Electric - optional
Hatch-back lid	Type (counterbalance, other)	Not applicable
	Internal release control (elec., mech., n.a.)	Not applicable
Station wagon		
Vent window control (crank, friction, pivot, power)	Front	None
	Rear	None
Seat cushion type (e.g., 60/40, bucket, bench, wire, foam etc.)	Front	Bench, formed full foam pad
	Rear	Bench, formed full foam pad
	3rd seat	Bench, formed full foam pad
Seat back type (e.g., 60/40, bucket, bench, wire, foam etc.)	Front	Bench, formed full foam pad
	Rear	Bench, formed full foam pad
	3rd seat	Bench, formed full foam pad

MVMA Specifications Form
Passenger Car
METRIC (U.S. Customary)

Car Line CHEVROLET
 Model Year 1987 Issued 6-86 Revised (•) _____

Body Type	4-Door Sedans	2 Door Coupe	4-Door Station Wagons
	1BL69 1BN69- 1BU69	1BN47	1BL35-1BN35

Restraint System

Active restraint system	Standard/optional	Standard
	Type and description	3 point shoulder & lap belt for driver and RH frt passenger, also rear seat outbord passengers. Lap belt for all other positions.
	Location	Front - (3); Rear - (3); Station Wagon 3rd seat - (2)
Passive seat belts	Standard/optional	Not available
	Power/manual	--
	2 or 3 point	--
	Knee bar/lap belt	--

Frame

Type and description (separate frame, unitized frame, partially-unitized frame)	Perimeter type, two crossmembers
---	----------------------------------

Glass	SAE Ref. No.			
Windshield glass exposed surface area [cm ² (in. ²)]	S1	8619 (1335.9)		
Side glass exposed surface area [cm ² (in. ²)] - total 2-sides	S2	12006 (1860.9)	10995 (1704.2)	19950 (3092.2)
Backlight glass exposed surface area [cm ² (in. ²)]	S3	5278 (818.1)	5567 (862.9)	4661 (722.5)
Total glass exposed surface area [cm ² (in. ²)]	S4	25903 (4015.0)	25181 (3903.1)	33230 (5150.6)
Windshield glass (type)		Curved - Laminated Plate		
Side glass (type)		Curved - Tempered Plate		
Backlight glass (type)		Curved - Tempered Plate		

MVMA Specifications Form
Passenger Car
METRIC (U.S. Customary)

Car Line CHEVROLET
 Model Year 1987 Issued 6-86 Revised (●) _____

Body Type

4-Door 1BL69	Sedans 1BN69- 1BU69	2-Door Coupe 1BN47	4-Door Station Wagon 1BL35-1BN35
-----------------	---------------------------	-----------------------	-------------------------------------

Convenience Equipment (standard, optional, n.a.)

Air conditioning (manual, auto. temp control)	Optional - Four season manual control	
Clock (digital, analog)	Digital clock in AM radio std, 1BN00, 1BU69, Opt 1BL00.	
Compass / thermometer	Compass - dealer installed	
Console (floor, overhead)	Not Available	
Defroster, elec. backlight	Optional	
Electronic	Diagnostic monitor (integrated, individual)	Not Available
	Instrument cluster (list instruments)	Not Available
	Keyless entry	Not Available
	Trip/finder (avg. spd., fuel)	Not Available
	Voice alert (list items)	Not Available
	Other	Radio tuning
Fuel door lock (remote, key, electric)	Not Available	
Lamps	Auto head on / off delay, dimming	Not Available
	Cornering	Optional
	Courtesy (map, reading)	Optional (2) in dome-lamp
	Door lock, ignition	Not Available
	Engine compartment	Optional
	Fog	Not Available
	Glove compartment	Standard
	Trunk	Standard Rear dome standard
Mirrors	Day night (auto. man.)	Manual-standard
	L.H. (remote, power, heated)	Remote-optional
	R. H. (convex, remote, power, heated)	Convex, manual or remote - optional
	Visor vanity (RH LH, illuminated)	Optional - RH
Parking brake-auto release (warning light)	Standard - hand release	
Power equipment	Door locks deck lid - specify	Door & tailgate locks Opt, deck lid release Opt
	Seat (2-4-6 way) heated (driver, pass, other) lumbar, hip, thigh support (power, manual) reclining (driver, pass) memory (1-2 preset, recline)	Optional - 6 way 50/50 power bench (left only) - 6 way power bench
	Side windows	Optional (door windows only)
	Vent windows	Not Available
	Rear window	Not Available Standard
		--
Radio systems	Antenna (location, whip, w shield, power)	Fixed mast, RH front fender, Power Opt
	AM, FM, stereo, tape, CB	Optional - AM, AM/FM, Stereo, Cassette
	Speaker (number, location) Premium sound	2 in inst panel, 2 in rear shelf or wgn rear pillars (A)
Roof open air-fixed (flip-up, sliding, "T")	Not Available	
Speed control device	Optional	
Speed warning device (light, buzzer, etc.)	Not Available	
Tachometer (rpm)	Not Available	
Telephone system - mobile		
Theft protection-type	Lock mounted on steering column; locks steering wheel, transmission shift lever and ignition.	

(A) Premium sound available for coupe and sedans.

MVMA Specifications Form

Passenger Car

Car Line CHEVROLET

Model Year 1987

Issued 6-86

Revised (•) _____

METRIC (U.S. Customary)

Car and Body Dimensions See Key Sheets for definitions

All dimensions to ground are for comparative purposes only. Dimensions are to be shown for all base body models of each car line. SAE Ref. no. refers to the definition published in SAE Recommended Practice J1100 "Motor Vehicle Dimensions," unless otherwise specified.

Body Type	SAE Ref. No.	4-Door Sedan 1B169	4-Door Sedan 1BN69-1BU69	2-Door Coupe 1BN47	4-Door Station Wagon 1BL35	1BN35
Width						
Tread (front)	W101	1568 (61.7)			1578 (62.2)	
Tread (rear)	W102	1542 (60.7)			1628 (64.1)	
Vehicle width	W103	1914 (75.4)			2014 (79.3)	
Body width at Sg RP (front)	W117	1910 (75.2)				
Vehicle width (front doors open)	W120	3291 (129.6)		4002 (157.6)	3291 (129.6)	
Vehicle width (rear doors open)	W121	3470 (136.6)		--	3426 (134.9)	
Front fender overall width	W106	1900 (74.8)				
Rear fender overall width	W107	1911 (75.2)			2014 (79.3)	
Tumble-home (deg.)	W122	24.5		25.5	24.5	

Length

Wheelbase	L101	2945 (116.0)				
Vehicle length	L103	5386 (212.2)	5405 (212.8)*		5464(215.1)	5483(215.7)*
Overhang (front)	L104	1030 (40.6)	1039.5(40.9)*		1030(40.6)	1039.5(40.9)*
Overhang (rear)	L105	1411 (55.6)	1420.5(55.9)*		1489(58.6)	1498.5(58.9)*
Upper structure length	L123	2366 (93.1)		2398 (94.4)	3506(138.0)	
Rear wheel C/L "X" coordinate	L127	2475 (97.4)				
Cowl point "X" coordinate	L125	236 (9.3)		239 (9.4)	235 (9.3)	
Front end length at centerline	L126	1623 (63.9)				
Rear end length at centerline	L129	1150 (45.3)		1115 (43.9)	100 (3.9)	

*Rub strips standard equipment on Caprice Classic sedan, coupe & wagon.

Height **

Passenger distribution (front/rear)	PD1.2.3			**		
Trunk/cargo load				**		
Vehicle height	H101	1433 (56.4)			1478 (58.2)	
Cowl point to ground	H114	1000 (39.4)			1010 (39.8)	
Deck point to ground	H138	1023 (40.3)			--	
Rocker panel-front to ground	H112	233 (9.2)			242 (9.5)	
Bottom of door closed-front to grd.	H133	295 (11.6)			295 (11.6)	
Rocker panel-rear to ground	H111	242 (9.5)			252 (9.9)	
Bottom of door closed-rear to grd.	H135	297 (11.7)		--	306 (12.0)	
Windshield slope angle	H122	53.5		54.0	53.5	
Backlight slope angle	H121	41.5		46.0	32.5	

Ground Clearance **

Front bumper to ground	H102	306 (12.1)			314 (12.4)	
Rear bumper to ground	H104	359 (14.1)	362 (14.3)		301 (11.8)	
Bumper to ground (front at curb mass (wt.))	H103	333 (13.1)			332 (13.1)	
Bumper to ground (rear at curb mass (wt.))	H105	377 (14.8)	380 (15.0)	380 (15.0)	311 (12.2)	
Angle of approach (degrees)	H106	18.0°			18.5°	
Angle of departure (degrees)	H107	14.0°			12.4°	
Ramp breakover angle (degrees)	H147	14.1°			14.5°	
Axle differential to ground (front / rear)	H153	192 (7.6)			194 (7.6)	
Min. running ground clearance	H156	148 (5.8)	187 (7.4)		200 (7.9)	
Location of min. run. grd. clear.		Front suspension				

**All Vehicle Height And Ground Clearances Are Made Using EPA Loaded Vehicle Weight, Loading Conditions.

EPA LOADED VEHICLE WEIGHT is The Base Vehicle Weight Plus All Coolant And Fluids Necessary For Operation Plus 100% Of The Fuel Capacity, Plus The Weight Of All Options And Accessories Which Weigh Three Pounds Or More And Which Are Sold On At Least 33% Of The Car Line, Plus Two Occupants.

MVMA Specifications Form
Passenger Car
METRIC (U.S. Customary)
Car and Body Dimensions See Key Sheets for definitions

Car Line CHEVROLET
 Model Year 1987 Issued 6-86 Revised (e) _____

Body Type	SAE Ref. No.	4-Door Sedans	2-Door Coupe	4-Door Station Wagon
		18L69 1BN69-1BU69	1BN47	1BL35 1BN35

Front Compartment

Sg RP front, "X" coordinate	L31	1078 (42.4)		
Effective head room	H61	1003 (39.5)	997 (39.3)	979 (38.5) 1005 (39.6)
Max. eff. leg room (accelerator)	L34	1072 (42.2)		
SgRP to heel point	H30	220 (8.7)		
SgRP to heel point	L53	876 (34.5)		
Back angle	L40	26.5		
Hip angle	L42	97.0		
Knee angle	L44	127.0		
Foot angle	L46	87.0		
Design H-point front travel	L17	163 (6.4)		
Normal driving & riding seat track trvl.	L23	143 (5.6)		
Shoulder room	W3	1536 (60.5)	1546 (60.9)	
Hip room	W5	1398 (55.0)		1400 (55.1)
Upper body opening to ground	H50			
Steering wheel maximum diameter	W9	387 (15.2)		
Steering wheel angle	H18	19.0		
Accel. heel pt. to steer. whl. cntr	L11			
Accel. heel pt. to steer. whl. cntr	H17			
Steering wheel to C/L of thigh	H13	105 (4.1)		104 (4.1)
Steering wheel torso clearance	L7	342 (13.5)		
Headlining to roof panel (front)	H37	13 (0.5)	19 (0.7)	14 (0.6)
Undepressed floor covering thickness	H67	6 (0.2)		

All Interior Dimensions Are Measured With The Seating Reference Point (SgRP) _____ mm (1 Seat Adjuster Notch) Forward Of Rearmost Seat Position.

Rear Compartment

Sg RP Point couple distance	L50	882 (34.7)	872 (34.3)	844 (33.2)
Effective head room	H63	971 (38.2)	965 (38.0)	964 (38.0) 999 (39.3)
Min. effective leg room	L51	992 (39.1)	972 (38.3)	959 (37.8) 946 (37.2)
Sg RP (second to heel)	H31	292 (11.5)	269 (10.6)	307 (12.1)
Knee clearance	L48	91 (3.6)	79 (3.1)	51 (2.0) 49 (1.9)
Compartment room	L3	736 (29.0)	737 (29.0)	720 (28.3)
Shoulder room	W4	1537 (60.5)	1546 (60.9)	1490 (58.7) 1548 (60.9)
Hip room	W6	1405 (55.3)	1464 (57.6)	1398 (55.0)
Upper body opening to ground	H51			
Back angle	L41	25.0°		26.5°
Hip angle	L43	92.5	89.0	92.0 91.0
Knee angle	L45	108.0	103.5	101.0 98.0
Foot angle	L47	127.0	127.5	122.0 121.0
Headlining to roof panel (second)	H38	12 (0.5)	18 (0.7)	19 (0.7) 30 (1.2)
Depressed floor covering thickness	H73	18 (0.7)		

Luggage Compartment

Usable luggage capacity [L (cu. ft.)]	V1	592L (20.9 cu. ft.)	--
Liftover height	H195	827 (32.6)	--

Interior Volumes (EPA Classification)

Vehicle class (subcompact, compact, etc.)		Large	
Interior volume index (cu. ft.)		110.3	106.3 110.5
Trunk/cargo index (cu. ft.)		20.9	50.3

All linear dimensions are in millimeters (inches).
 ** EPA Loaded Vehicle Weight, Loading Conditions

MVMA Specifications Form

Passenger Car

METRIC (U.S. Customary)

Car and Body Dimensions

See Key Sheets for definitions

Car Line CHEVROLET

Model Year 1987

Issued 6-86

Revised (e) 10-86

Body Type

SAE
Ref.
No.

Station Wagon - 3 Seat
1B135-1B135

Station Wagon - Third Seat

Sg RP couple distance	L85	985 (38.8)
Shoulder room	W85	1240 (48.8)
Hip room	W86	1109 (43.7)
Effective leg room	L86	782 (30.8)
Effective head room	H86	948 (37.3)
Sg RP to heel point	H87	257 (10.1)
Knee clearance	L87	317 (12.5)
Seat facing direction	SD1	Rearward
Back angle	L88	25.0°
Hip angle	L89	76.5
Knee angle	L90	70.5
Foot angle	L91	114.5

Station Wagon - Cargo Space

Cargo length (open front)	L200	2790 (109.8)
Cargo length (open second)	L201	1907 (75.1)
Cargo length (closed front)	L202	2290 (90.2)
Cargo length (closed second)	L203	1407 (55.4)
Cargo length at belt (front)	L204	2129 (83.8)
Cargo length at belt (second)	L205	1222 (48.1)
Cargo width (wheelhouse)	W201	1224 (48.2)
Rear opening width at floor	W203	1238 (48.7)
Opening width at belt	W204	1224 (48.2)
Max. rear opening width above belt	W205	988 (38.9)
Cargo height	H201	755 (29.7)
Rear opening height	H202	729 (28.7)
Tailgate to ground height	H250	768 (30.2)
Front seat back to load floor height	H197	--
Cargo volume index [m ³ (ft. ³)]	V2	2488L (87.9 cu. ft.)
Hidden cargo volume [m ³ (ft. ³)]	V4	Not Available
Cargo volume index-rear of 2-seat	V10	1428L (50.4 cu. ft.)

Hatchback - Cargo Space

Cargo length at front seatback height	L208	
Cargo length at floor (front)	L209	Not Applicable
Cargo length at second seatback height	L210	
Cargo length at floor (second)	L211	
Front seatback to load floor height	H197	
Second seatback to load floor height	H198	
Cargo volume index [m ³ (ft. ³)]	V3	
Hidden cargo volume [m ³ (ft. ³)]	V4	
Cargo volume index-rear of 2-seat	V11	

Aerodynamics*

	4-Door Sedans	2-Door Coupe	Station Wgn
Wheel lip to ground, front	H172	709 (27.9)	715 (28.1)
Wheel lip to ground, rear	H173	712 (28.0)	723 (28.5)
Frontal area [m ² (ft. ²)]		2.31(24.9)	2.54(27.3)
Drag coefficient (Cd)		Not Available	

* EPA Loaded Vehicle Weight, Loading Conditions

All linear dimensions are in millimeters (inches) unless otherwise noted.

MVMA Specifications Form
Passenger Car
METRIC (U.S. Customary)

Car Line CHEVROLET
 Model Year 1987 Issued 6-86 Revised (●) _____

Body Type	4-Door Sedans	2-Door Coupe	4-Door Station Wagon
	1BL69 1BN69- 1BU69	1BN47	1BL35-1BN35

Vehicle Fiducial Marks

Fiducial Mark Number*	Define Coordinate Location
Front	X - Fiducial marks to vertical base grid line-front, measured horizontally from the base grid line to the front fiducial mark located on top of the front seat adjuster mounting bolt.
	Y - Fiducial mark to centerline of car-front, width measurement made from centerline of car to fiducial mark located on top of the front seat adjuster mounting bolt.
	Z - Fiducial mark to horizontal base grid line-front, measured vertically from base grid line to front fiducial mark located on top of the front seat adjuster mounting bolt.
Rear	X - Fiducial mark to vertical base grid line-rear measured horizontally from base grid line to the rear fiducial mark located on rail (compartment pan - longitudinal).
	Y - Fiducial mark to centerline of car-rear, width measurement made from centerline of car to fiducial mark located on the rail (compartment pan - longitudinal).
	Z - Fiducial mark to horizontal base grid line-rear, measured vertically from base grid line to the rear fiducial mark located on rail (compartment pan - longitudinal).

Front	W21	564 (22.2)	
	L54	754 (29.7)*	
	H81	9 (0.4)#	
	H161	348 (13.7)	349 (13.7)
	** H163	325 (12.8)	332 (13.1)

Rear	W22	254 (10.0)	302 (11.9)
	L55	3533 (139.1)*	3440 (135.4)*
	H82	86 (3.4)#	-34 (-1.3)#
	H162	449 (17.7)	331 (13.0)
	** H164	431 (17.0)	319 (12.6)

* Vertical Base Grid 2000 mm Line.
 # Horizontal Base Grid 500 mm Line.

* Reference - SAE Recommended Practice, J182, Motor Vehicle Fiducial Marks.

All linear dimensions are in millimeters (inches).

** EPA Loaded Vehicle Weight, Loading Conditions

MVMA Specifications Form
Passenger Car
METRIC (U.S. Customary)

Car Line CHEVROLET
 Model Year 1987 Issued 6-86 Revised (●) _____

Body Type	4-Door Sedans	2-Door Coupe	4-Door Station Wagon
	1BL69	1BN69- 1BU69	1BN47 1BL35-1BN35

Lamps and Headlamp Shape*

Height above ground to center of bulb or marker	Headlamp (SAE - H127)	Highest**	706.5(27.8)		705.9(27.8)
		Lowest	705.6(27.8)		705.0(27.8)
	Taillamp (SAE - H128)	Highest**	707.1(27.8)		727.5(28.6)
		Lowest	704.4 (27.7)		--
	Sidemarker	Front	665.0(26.2)		664.4(25.4)
		Rear	699.0(27.5)		588.7(23.2)
Distance from C.L. of car to center of bulb	Headlamp	Inside	562.0(22.1)	566.0(22.3)	566.0(22.3)
		Outside**	737.2(29.0)	741.2(29.2)	741.2(29.2)
	Taillamp	Inside	419.0(16.5)	370.0(14.6)	906.6(35.7)
		Outside**	775.0(30.5)	779.0(30.7)	916.0(36.1)
	Directional	Front	721.0(28.4)		721.0(28.4)
		Rear	775.0(30.5)	779.0(30.7)	916.0(36.1)
	Halogen headlamp (std., opt., n.a.)	Lo beam	Std.		
		Hi beam	Std.		
Replaceable bulb		Yes			
Shape		Rectangular			
Headlamp other than above	Lo beam	Not Available			
	Hi beam	"	"		
	Replaceable	"	"		
	Shape	"	"		
	Type	"	"		

* Measured at curb mass (weight).
 ** If single lamps are used enter here.
 All linear dimensions are in millimeters (inches) unless otherwise noted.

MVMA Specifications Form Passenger Car

Car Line CHEVROLET
 Model Year 1987 Issued 6-86 Revised (●) _____

METRIC (U.S. Customary)

Model	Vehicle Mass (weight)							SHIPPING MASS, kg (weight, lb.)**
	CURB MASS, kg. (weight, lb.)*			% PASS. MASS DISTRIBUTION				
	Front	Rear	Total	Pass In Front		Pass In Rear		
				Front	Rear	Front	Rear	
Caprice								
4-Door Sedan 1BL69 (a)	854.6 (1884)	737.8 (1626)	1592.4 (3510)					1530.8 (3375)
4-Door, 3-Seat (b) Station Wagon 1BL35	902.9 (1990)	963.4 (2124)	1866.3 (4114)					1812.6 (3996)
Caprice Classic								
4-Door Sedan 1BN69 (a)	858.7 (1893)	741.1 (1634)	1599.8 (3527)					1538.2 (3391)
2-Door Coupe 1BN47 (a)	855.1 (1885)	738.2 (1627)	1593.3 (3512)					1531.7 (3377)
4-Door, 3-Seat (b) Station Wagon 1BN35	905.3 (1996)	965.7 (2129)	1871.0 (4125)					1817.3 (4006)
Caprice Classic Brougham								
4-Door Sedan 1BU69	871.2 (1921)	750.7 (1655)	1621.9 (3576)					1560.3 (3440)
(a) with V6 - 262 CID 4.3 Liter Engine								
(b) with V8 - 307 CID 5.0 Liter Engine								
Curb Weight - The calculated weight of a vehicle with standard equipment only as designed with the additional load of oil, lubes, coolants, and fuel all filled to capacity.								
Shipping Weight - Same as base curb weight, except 3 gallons of gasoline.								

* Reference - SAE J1100 Motor vehicle dimensions, curb weight definition.
 ** Shipping mass (weight) definition -

MVMA Specifications Form Passenger Car

Car Line CHEVROLET
Model Year 1987 Issued 6-86 Revised (●) _____

METRIC (U.S. Customary)

Equipment	Optional Equipment Differential Mass (weight)*			Remarks
	MASS, kg. (weight, lb.)			
	Front	Rear	Total	
Power Front Seat 6-Way Pass., Split Bench (Used with AG1 & AG9) Requires A31 RPO AG2	2.6 (5.7)	2.4 (5.3)	5.0 (11.0)	All Models
Power Front Seat 6-Way (Used with RPO-AG1 or A42.) RPO-AG9 Requires A31	2.6 (5.7)	2.4 (5.3)	5.0 (11.0)	1BL00, 1BN00 Models
Reclining Seat Back - Requires RPO - AV7 - R.H. Seat back only. RPO-AT6	4.8 (10.6)	9.6 (21.2)	14.4 (31.8)	All Models
Electric Side Door Lock System RPO-AU3	1.0 (2.2)	0.8 (1.8)	1.8 (4.0)	2-Door Model
	1.8 (4.0)	1.4 (3.1)	3.2 (7.1)	4-Door Models
Front Seat - 50/50 RPO-AV7	4.8 (10.6)	9.6 (21.2)	14.4 (31.8)	1BL00 & 1BN00 Models
Electric Window Control RPO-A31	1.4 (3.1)	1.0 (2.2)	2.4 (5.3)	2-Door Models
	2.4 (5.3)	2.6 (5.7)	5.0 (11.0)	4-Door Models
Trunk Lid Release - Electric-Remote.RPO-A90	0 (0)	.6 (1.3)	.6 (1.3)	1BL69, 1BN47-69, 1BU69
Deluxe Cargo Area Carpet. (Consists of RPO-B39) RPO-BC5	0 (0)	.6 (1.3)	.6 (1.3)	1BL35, 1BN35
Acoustical Insulation Package (Quiet sound Group.) RPO-BS1	3.2 (7.0)	5.6 (12.4)	8.8 (19.4)	1BL00, Base on 1BN00/1BU69 models.
Woodgrain Applique and Molding (Body side and Tailgate. Not with RPO-D84.) RPO-BX3	.8 (1.8)	1.6 (3.5)	2.4 (5.3)	1BL35, 1BN35 Caprice Estate

*Also see Engine - General Section for dressed engine mass (weight).

MVMA Specifications Form Passenger Car

Car Line CHEVROLET
Model Year 1987 Issued 6-86 Revised (•) _____

METRIC (U.S. Customary)

Equipment	Optional Equipment Differential Mass (weight)*			Remarks
	MASS, kg. (weight, lb.)			
	Front	Rear	Total	
ElectrocLEAR Rear	0	.6	.6	1BL69 - 1BN47 & 69, 1BUU69
Window Defogger	(0)	(1.3)	(1.3)	
RPO-C49	0	.8	.8	1BL35, 1BN35
	(0)	(1.8)	(1.8)	
Air Deflector, Rear	0	2.6	2.6	1BL35, 1BN35
Window, (Forces RPO-V55)	(0)	(5.7)	(5.7)	
RPO-C51				
Air Conditioning-Manual Control, (Consists of RPO-K64)	25.0 (55.1)	1.6 (3.5)	26.6 (58.6)	With 1BL69 and RPO-LB4
RPO-C60	24.0 (52.9)	1.6 (3.5)	25.6 (56.4)	With 1BN47-69/1BU69 and RPO-LB4
	28.2 (62.2)	1.6 (3.5)	29.8 (65.7)	With 1BL69 and RPO-LG4
Air Conditioning - Manual Control (Consists of RPO-K64)	27.2 (60.0)	1.6 (3.5)	28.8 (63.5)	With 1BN47-69/1BU69 and RPO-LG4
RPO-C60	29.6 (65.2)	1.6 (3.5)	31.2 (68.7)	With 1BL69 and RPO LMI
Air Conditioning-Manual Control (Consists of RPO-K64)				1BL35 & 1BN35 and RPO LV2
RPO C60				
Outside Mirror - Remote Control LH only - Painted	.4 (0.9)	0 (0)	.4 (0.9)	All models
RPO-D33				
Outside Sport Mirrors - LH Remote Control, RH Manual Painted	1.0 (2.2)	.4 (0.9)	1.4 (3.1)	All models
RPO-D35				
Visor Vanity Mirror - RH Visor-Illuminated	.4 (0.9)	0 (0)	.4 (0.9)	All models
RPO-D64				
Outside Mirrors - LH and RH Remote Control, Painted	1.4 (3.1)	.4 (0.9)	1.8 (4.0)	All models
RPO-D68				
Suspension - Heavy Duty Front & Rear (N/A F41 Suspension)				1BL69, 1BN47-69, 1BU69 Std. on 1BL35, 1BN35
RPO-F40				

*Also see Engine - General Section for dressed engine mass (weight).

MVMA Specifications Form Passenger Car

Car Line CHEVROLET
Model Year 1987 Issued 6-86 Revised (e) _____

METRIC (U.S. Customary)

Equipment	Optional Equipment Differential Mass (weight)*			Remarks
	MASS, kg. (weight, lb.)			
	Front	Rear	Total	
Sport Suspension	3.0	11.4	14.4	1BL69, 1BN47-69, 1BU69
Equipment - Front & Rear. Requires RPO-QHK. Consists of PH1.	(6.6)	(25.1)	(31.7)	
RPO-F41				
Air Booster Rear Shock Absorbers. RPO-G66	0 (0)	1.0 (2.2)	1.0 (2.2)	1BL35, 1BN35
Engine Block Heater RPO-K05	.4 (0.9)	0 (0)	.4 (0.9)	All models
Cruise Control - 3 Mode (Cruise Master), with Resume Feature. RPO-K34	1.4 (3.1)	.4 (0.9)	1.8 (4.0)	All models
Engine 5.0 Liter 4-Bbl. (305 C.I.D.) V8. RPO-LG4	41.0 (90.4)	1.0 (2.2)	42.0 (92.6)	Opt all models, except wagons
Engine 5.7 Liter 4-Bbl. (350 C.I.D.) V8. RPO-LM1	66.8 (147.3)	5.8 (12.8)	72.6 (160.1)	1BL69 - Police only
Engine 5.0 Liter 4-Bbl. (307 C.I.D.) V8 RPO LV2				1BL35/1BN35 models only
Automatic Transmission 4-Speed, with Overdrive. RPO-MX0	2.0 (4.4)	1.0 (2.2)	3.0 (6.6)	1BL69, 1BN47-69, 1BU69 Standard on 1BL35/1BN35
Tilt Steering Column (Comfortilt. RPO-N33	.8 (1.8)	.2 (0.4)	1.0 (2.2)	All models
Simulated Wire Wheel Covers. RPO-N91	2.8 (6.2)	2.8 (6.2)	5.6 (12.4)	All models
Wheel Trim Covers - Sport Consists of RPO-PB2	.8 (1.8)	.8 (1.8)	1.6 (3.6)	All models
Auxilliary Lighting Group Consists of:	.2 (0.4)	0 (0)	.2 (0.4)	All models
-Underhood Lamp RPO-U26				All
-I.P. Courtesy Lamps RPO-U29				1BL00 (Std on 1BN00/1BU69)
-Dome Reading Lamp RPO-C95				All models, std. on 1BU69

*Also see Engine - General Section for dressed engine mass (weight).

**MVMA Specifications Form
Passenger Car**

Car Line CHEVROLET
Model Year 1987 Issued 6-86 Revised (•) _____

METRIC (U.S. Customary)

Optional Equipment Differential Mass (weight)*

Equipment	MASS, kg. (weight, lb.)			Remarks
	Front	Rear	Total	
Lamps - Cornering RPO-T87	1.4 (3.1)	-.2 (-0.4)	1.2 (2.7)	All models
Heavy Duty Battery RPO-UA1	2.8 (6.2)	-.4 (-0.9)	2.4 (5.3)	With RPO LG4, LM1, LV2
Gauge Package Consists of: Gages and Trip Odometer RPO-U14	.4 (0.9)	0 (0)	.4 (0.9)	All Models
AM/FM Stereo Radio (ETR) Full Feature Consists of U64, UP8 RPO-UK4				All Models
Radio AM with Clock Consists of UP7 RPO-UL6				1BLO0, Base 1BN00, 1BU69
AM/FM Stereo Radio with Clock Cassette Player -Consists of RPO-U64,UP8 RPO-UM6	2.0 (4.4)	1.0 (2.2)	3.0 (6.6)	All models
AM/FM Stereo Radio with Equalizer, Cassette, Clock -Consists of RPO U79,U64 UP8 RPO UU6	2.0 (4.4)	.8 (1.8)	2.8 (6.2)	All models
AM/FM Stereo Radio (ETR) Full Feature with Clock Consists of U64, UP8, RPO-UM7				All models
AM Radio-Consists of RPO-UP7, RPO-U63	2.6 (5.7)	.6 (1.3)	3.2 (7.0)	Standard on 1BLO0 only
Power Antenna Radio Suppression Equip. RPO-U75	1.4 (3.1)	.2 (0.4)	1.6 (3.5)	All models

*Also see Engine - General Section for dressed engine mass (weight).

MVMA Specifications Form
Passenger Car
METRIC (U.S. Customary)

Exterior Car And Body Dimensions – Key Sheet

Exterior Width

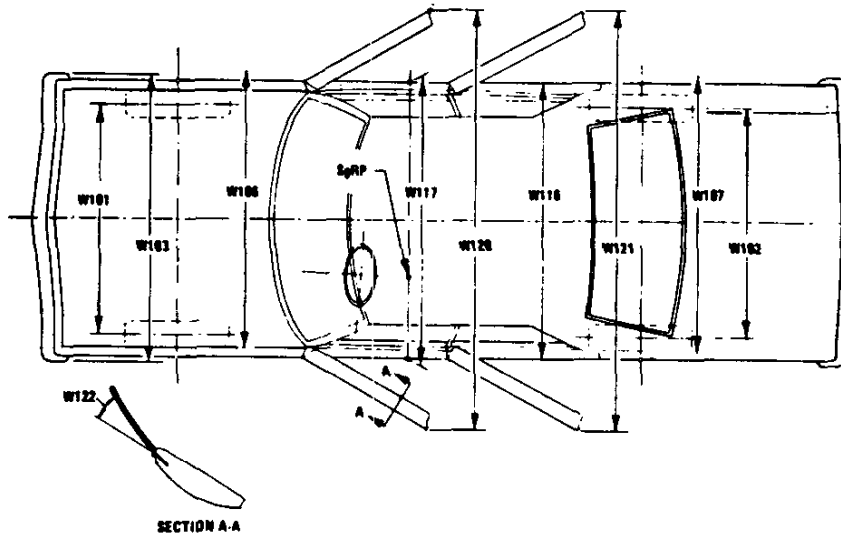

Exterior Length & Height

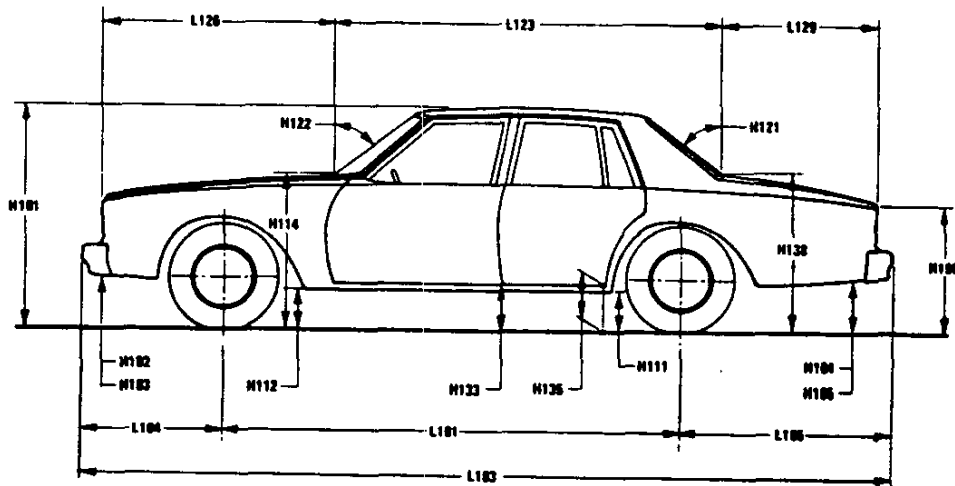

Exterior Ground Clearance

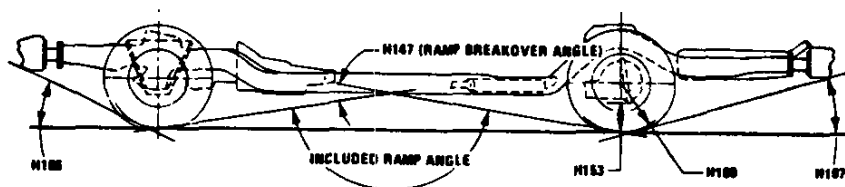

MVMA Specifications Form

Passenger Car

METRIC (U.S. Customary)

Interior Car And Body Dimensions – Key Sheet

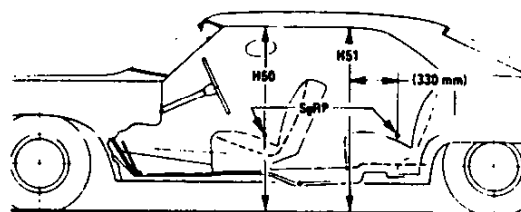
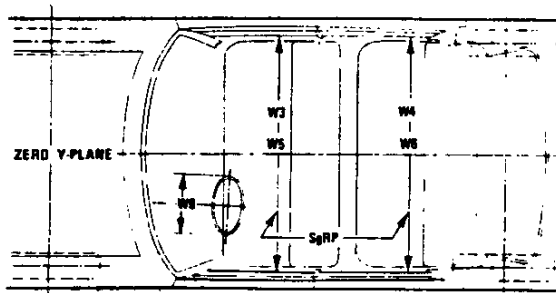
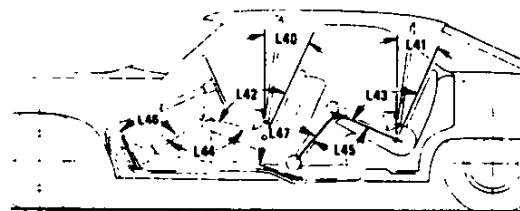
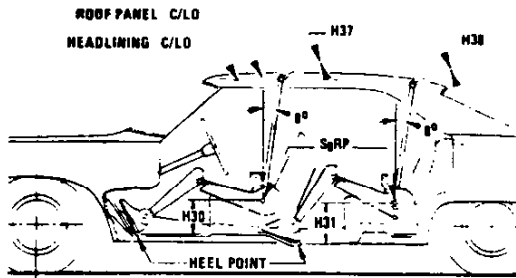
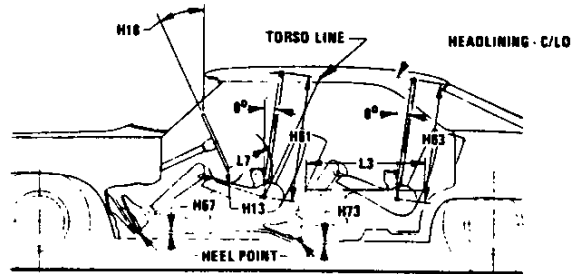
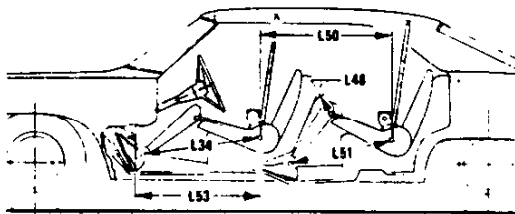

MVMA Specifications Form
Passenger Car
METRIC (U.S. Customary)

Interior Car And Body Dimensions – Key Sheet

Third Seat

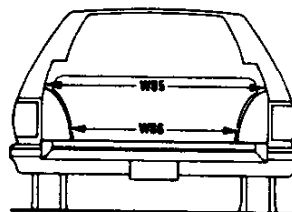
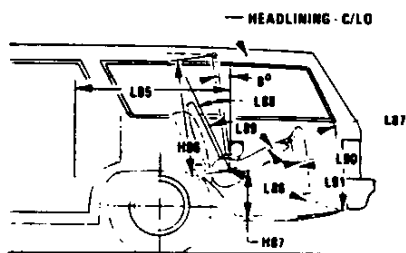

Cargo Space

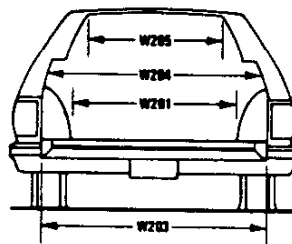
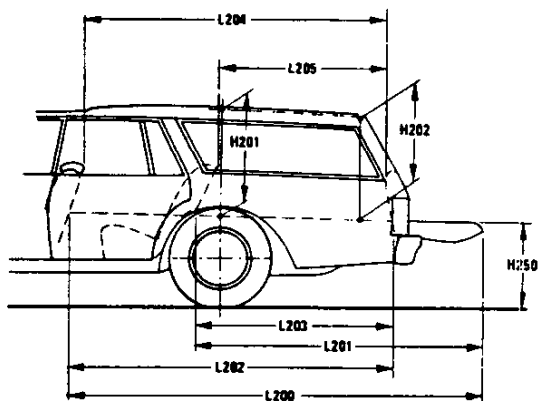

Station Wagon

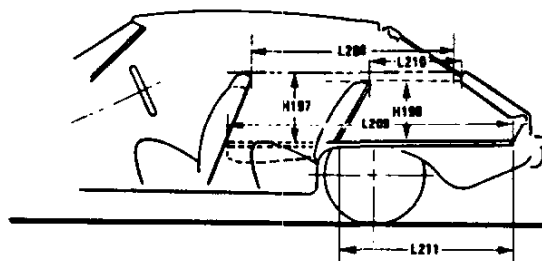

Hatchback

MVMA Specifications Form

Passenger Car

METRIC (U.S. Customary)

Interior Car And Body Dimensions – Key Sheet

Dimensions Definitions

- H104 REAR BUMPER TO GROUND. The minimum dimension measured vertically from the lowest point on the rear bumper to ground, including bumper guards, if standard equipment.
- H105 REAR BUMPER TO GROUND – CURB MASS (WT.). Measured in the same manner as H104.
- H106 ANGLE OF APPROACH. The angle measured between a line tangent to the front tire static loaded radius arc and the initial point of structural interference forward of the front tire to ground. The limiting structural component shall be designated.
- H107 ANGLE OF DEPARTURE. The angle measured between a line tangent to the rear tire static loaded radius arc and the initial point of structural interference rearward of the rear tire to ground. The limiting component shall be designated.
- H147 RAMP BREAKOVER ANGLE. The angle measured between two lines tangent to the front and rear tire static loaded radius and intersecting at a point on the underside of the vehicle which defines the largest ramp over which the vehicle can roll.
- H153 REAR AXLE DIFFERENTIAL TO GROUND. The minimum dimension measured from the rear axle differential to ground.
- H156 MINIMUM RUNNING GROUND CLEARANCE. The minimum dimension measured from the sprung vehicle to ground. Specify location.
- Glass Areas**
- S1 Windshield area.
- S2 Side windows area. Includes the front door, rear door, vents, and rear quarter windows on both sides of the vehicle.
- S3 Backlight areas.
- S4 Total area. Total of all areas (S1 + S2 + S3).
- Fiducial Mark Dimensions**
- Fiducial Mark – Number 1**
- L54 "X" coordinate.
- W21 "Y" coordinate.
- H81 "Z" coordinate.
- H161 Height "Z" coordinate to ground at curb weight.
- H163 Height "Z" coordinate to ground.
- Fiducial Mark – Number 2**
- L55 "X" coordinate.
- W22 "Y" coordinate.
- W82 "Z" coordinate.
- H162 Height "Z" coordinate to ground at curb weight.
- H164 Height "Z" coordinate to ground.
- Front Compartment Dimensions**
- L7 STEERING WHEEL TORSO CLEARANCE. The minimum dimension measured in the side view from the rearmost edge of the steering wheel, with front wheels in the straight ahead position, to the torso line.
- L11 ACCELERATOR HEEL POINT TO STEERING WHEEL CENTER. The dimension measured horizontally from the AHP to the intersection of the steering column centerline and a plane tangent to the upper surface of the steering wheel rim.
- L17 DESIGN H-POINT–FRONT TRAVEL. The dimension measured horizontally between the design H-point–front in the foremost and rearmost seat track positions. (See SAE J1100)
- L23 NORMAL DRIVING AND RIDING SEAT TRACK LEVEL. The dimension measured horizontally between a point on the design H-point travel line from the SgRP to the displaced point on the design H-point travel line with the seat moved to the foremost seat position, but not to include seat track travel used for purposes other than normal driving and riding positions. (See SAE J1100)
- L31 SgRP–FRONT. "X" COORDINATED.
- L34 MAXIMUM EFFECTIVE LEG ROOM–ACCELERATOR. The dimension measured along a line from the ankle pivot center to the SgRP–front plus 254 mm (10.0 in.) measured with right foot on the undepressed accelerator pedal. For vehicles with SgRP to heel (H30) greater than 18 in., the accelerator pedal may be depressed as specified by the manufacturer. If the accelerator is depressed, the manufacturer shall place foot flat on pedal and note the depression of the pedal.
- L40 BACK ANGLE–FRONT. The angle measured between a vertical line through the SgRP–front and the torso line. If the seatback is adjustable, use the normal driving and riding position specified by the manufacturer.
- L42 HIP ANGLE–FRONT. The angle measured between torso line and thigh centerline.
- L44 KNEE ANGLE–FRONT. The angle measured between thigh centerline and lower leg centerline measured on the right leg.
- L46 FOOT ANGLE–FRONT. The angle measured between the lower leg centerline and a line tangent to the ball and heel of the bare foot flesh line measured on the right leg. Ref SAE J826.
- L53 SgRP–FRONT TO HEEL. The dimension measured horizontally from the SgRP–front to the accelerator heel point.
- W3 SHOULDER ROOM–FRONT. The minimum dimension measured laterally between the trimmed surfaces on the "X" plane through the SgRP–front at height between the belt line and 254 mm (10.0 in.) above the SgRP–front, excluding the door assist strap and attaching parts.
- W5 HIP ROOM–FRONT. The minimum dimension measured laterally between the trimmed surfaces on the "X" plane through the SgRP–front within 25 mm (1.0 in.) below and 76 mm (3.0 in.) above the SgRP–front and 76 mm (3.0 in.) fore and aft of the SgRP–front.
- W9 STEERING WHEEL MAXIMUM OUTSIDE DIAMETER. Define if other than round.
- H13 STEERING WHEEL TO CENTERLINE OF THIGH. The minimum dimension measured from the bottom of steering wheel, with front wheels in the straight position, to the thigh centerline.
- H17 ACCELERATOR HEEL POINT TO THE STEERING WHEEL CENTER. The dimension measured vertically from the AHP–front to the intersection of the steering column centerline to a plane tangent to the upper surface of the steering wheel rim.
- H18 STEERING WHEEL ANGLE. The angle measured from a vertical to the surface plane of the steering wheel.
- H30 SgRP–FRONT TO HEEL. The dimension measured vertically from the SgRP–front to the accelerator heel point.
- H37 HEADLINING TO ROOF PANEL–FRONT. The dimension measured from the intersection of the headlining and the extended effective head room line normal to the sheet metal.
- H50 UPPER BODY OPENING TO GROUND–FRONT. The dimension measured vertically from the trimmed body opening to the ground on the SgRP–front "X" plane.
- H61 EFFECTIVE HEAD ROOM–FRONT. The dimension measured along a line 8 deg. rear of vertical from the SgRP–front to the headlining plus 102 mm (4.0 in.).
- H67 FLOOR COVERING THICKNESS–UNDEPRESSED–FRONT. The dimension measured vertically from the surface of the undepressed floor covering to the underbody sheet metal at the accelerator heel point.
- PD1 PASSENGER DISTRIBUTION–FRONT.
- Rear Compartment Dimensions**
- L3 COMPARTMENT ROOM–SECOND. The dimension measured horizontally from the back of front seat to the front of the second seatback at a height tangent to the top of the second seat cushion.

MVMA Specifications Form

Passenger Car

METRIC (U.S. Customary)

Exterior Car And Body Dimensions – Key Sheet

Dimensions Definitions

Seating Reference Point

SEATING REFERENCE POINT means the manufacturer's design reference point which –

- (a) Establishes the rearmost normal design driving or riding position of each designated seating position in a vehicle;
- (b) Has coordinates established relative to the design vehicle structure;
- (c) Simulates the position of the pivot center of the human torso and thigh; and
- (d) Is the reference point employed to position the two dimensional templates described in SAE Recommended Practice J826, "Devices for Use in Defining and Measuring Vehicle Seating Accommodations."

Width Dimensions

- W101 TREAD–FRONT. The dimension measured between the tire centerlines at the ground.
- W102 TREAD–REAR. The dimension measured between the tire centerlines at the ground. In case of dual wheels, the dimension will be measured to the centerline of tire and wheel assemblies.
- W103 VEHICLE WIDTH. The maximum dimension measured between the widest point on the vehicle, excluding exterior mirrors, flexible mud flaps, marker lamps, but including bumpers, moldings, sheet metal protrusions or dual wheels, if standard equipment.
- W106 FRONT FENDER WIDTH. The dimension measured between the widest points at the front wheel centerline, excluding moldings.
- W107 REAR FENDER WIDTH. The dimension measured between the widest points at the rear wheel centerline, excluding moldings.
- W117 BODY WIDTH AT SgRP–FRONT. The dimension measured laterally between the widest points on the body at the SgRP–front, excluding door handles, applied moldings, or appliques.
- W120 VEHICLE WIDTH–FRONT DOORS OPEN. The dimension measured between the widest point on the front doors in maximum hold-open position.
- W121 VEHICLE WIDTH–REAR DOORS OPEN. The dimension measured between the widest point on the rear doors in maximum hold-open position. For vehicles with a rear door on only one side, this dimension is to the zero "Y" plane.
- W122 TUMBLE–HOME, STRAIGHT SIDE GLASS. The angle measured from a vertical to the outside surface of the front door glass at the SgRP "X" plane.
CURVED SIDE GLASS. The angle measured from a vertical to a chord extending from the upper DLO to the lower DLO at the outside surface of the front door glass at the front SgRP "X" plane.

Length Dimensions

- L101 WHEELBASE (WB). The dimension measured longitudinally between front and rear wheel centerlines. In case of dual rear axles, the dimension shall be to the midpoint of the centerlines of the rear wheels.
- L103 VEHICLE LENGTH. The maximum dimension measured longitudinally between the foremost point and the rearmost point on the vehicle, including bumper, bumper guards, tow hooks and or rub strips, if standard equipment.
- L104 OVERHANG–FRONT. The dimension measured longitudinally from the centerline of the front wheels to the foremost point on the vehicle including bumper, bumper guards, tow hooks and or rub strips, if standard equipment.
- L105 OVERHANG–REAR. The dimension measured longitudinally from the centerline of the rear wheels; or in the case

of dual rear axles, the dimension shall be the midpoint of the centerlines of the rear wheels, to the rearmost point on the vehicle including rear bumpers, bumper guards, tow hooks and rub strips, if standard equipment.

- L123 UPPER STRUCTURE LENGTH. The dimension measured longitudinally from the cowl point to the deck point.
- L125 COWL POINT "X" COORDINATE.
- L126 FRONT END LENGTH. The dimension measured longitudinally from the cowl point to the foremost point on the vehicle at the zero "Y" plane excluding ornamentation or bumpers. In cases where bumpers and or grills are integrated with the profile, measurement is made at the foremost point of front end contour.
- L127 REAR WHEEL CENTERLINE "X" COORDINATE or in the case of dual rear axles, the coordinate shall be the midpoint of the distance between the rear axle centerlines.
- L129 REAR END LENGTH. The dimension measured longitudinally from the deck point to the rearmost visible point of the body sheet metal at the zero "Y" plane, excluding ornamentation or bumpers.

Height Dimensions

- H101 VEHICLE HEIGHT. The dimension measured vertically from the highest point on the vehicle body to ground.
- H111 ROCKER PANEL–REAR TO GROUND. The dimension measured vertically from the bottom of the rocker or side quarter panel at the front of the rear wheel opening, excluding flanges, to ground.
- H112 ROCKER PANEL–FRONT TO GROUND. The dimension measured vertically from the foremost point on the bottom of the rocker panels, excluding flanges, to ground.
- H114 COWL POINT TO GROUND. Measured at zero "Y" plane.
- H121 BACKLIGHT SLOPE ANGLE. The angle between the vertical reference line and the surface of backlight at vehicle zero "Y" plane. For curve backlight, the angle is to chord of backlight arc from lower DLO to upper DLO.
- H122 WINDSHIELD SLOPE ANGLE. The angle between the vertical reference line and a chord of the windshield arc running from the lower DLO to the upper DLO at the vehicle zero "Y" plane. In the case of wrap over glass, the angle to be measured will be formed by a chord 457 mm (18.0 in) long drawn from the lower DLO to the intersecting point on the windshield.
- H127 HEADLAMP TO GROUND–CURB MASS (WT.). The dimension measured vertically from the centerline of the lowest headlamp lens to ground.
- H128 TAILLAMP TO GROUND–CURB MASS (WT.). The dimension measured vertically from the centerline of the upper bulb to ground.
- H133 BOTTOM OF DOOR CLOSED–FRONT TO GROUND. The dimension measured vertically from the bottom outside corner of the door on the lock pillar side, in maximum closed position, to ground.
- H135 BOTTOM OF DOOR CLOSED–REAR TO GROUND. The dimension measured vertically from the bottom outside corner of the door on the lock pillar side, in maximum closed position, to ground.
- H138 DECK POINT TO GROUND. Measured at zero "Y" plane.
- H109 STATIC LOAD–TIRE RADIUS–REAR. Specified by the manufacturer in accordance with composite TIRE SECTION STANDARD.

Ground Clearance Dimensions

- H102 FRONT BUMPER TO GROUND. The minimum dimension measured vertically from the lowest point on the front bumper to ground, including bumper guards, if standard equipment.
- H103 FRONT BUMPER TO GROUND–CURB MASS (WT.). Measured in the same manner as H102.

MVMA Specifications Form Passenger Car

METRIC (U.S. Customary)

Interior Car And Body Dimensions – Key Sheet Dimensions Definitions

- W203 REAR OPENING WIDTH AT FLOOR. The minimum dimension measured laterally between the limiting interferences of the rear opening at floor level.
- W204 REAR OPENING WIDTH AT BELT. The minimum dimension measured laterally between the limiting interferences of the rear opening at belt height or top of pick up box.
- W205 REAR OPENING WIDTH ABOVE BELT. The minimum dimension measured laterally between the limiting interferences of the rear opening above the belt height.
- H197 FRONT SEATBACK TO LOAD FLOOR HEIGHT. The dimension measured vertically from the horizontal tangent to the top of the seatback to the undepressed floor covering.
- H201 CARGO HEIGHT. The dimension measured vertically from the top of the undepressed floor covering to the headlining at the rear wheel "X" coordinate on the zero "Y" plane.
- H202 REAR OPENING HEIGHT. The dimension measured vertically from the top of the undepressed floor covering to the upper trimmed opening on the zero "Y" plane with rear door fully open.
- H250 TAILGATE TO GROUND CURB MASS (WT.). The dimension measured vertically from the top of the undepressed floor covering on the lowered tailgate to ground on the zero "Y" plane.
- V2 STATION WAGON
Measured in inches:

$$\frac{W4 \times H201 \times L204}{1728} = \text{ft}^3$$
 Measured in mm:

$$\frac{W4 \times H201 \times L204}{10^9} = \text{m}^3 \text{ (cubic meter)}$$
- V4 HIDDEN LUGGAGE CAPACITY-REAR OF FRONT SEAT. The total volumes of individual pieces of one set of standard luggage stowed in any hidden cargo area below the load floor rear of the front seat.
- V5 TRUCKS AND MPV'S WITH OPEN AREA.
Measured in inches:

$$\frac{L506 \times W500 \times H503}{1728} = \text{ft}^3$$
 Measured in mm:

$$\frac{L506 \times W500 \times H503}{10^9} = \text{m}^3 \text{ (cubic meter)}$$
- V6 TRUCKS AND MPV'S WITH CLOSED AREA.
Measured in inches:

$$\frac{L204 \times W500 \times H505}{1728} = \text{ft}^3$$
 Measured in mm:

$$\frac{L204 \times W500 \times H505}{10^9} = \text{m}^3 \text{ (cubic meter)}$$
- V8 HIDDEN LUGGAGE CAPACITY-REAR OF SECOND SEAT. The total volume of individual pieces of one set of standard luggage stowed in any hidden cargo area below the load floor rear of the second seat.
- V10 STATION WAGON CARGO VOLUME INDEX.
Measured in inches:

$$\frac{H201 \times L205 \times \frac{W4 + W201}{2}}{1728} = \text{ft}^3$$
 Measured in mm:

$$\frac{H201 \times L205 \times \frac{W4 + W201}{2}}{10^9} = \text{m}^3 \text{ (cubic meter)}$$

Hatchback – Cargo Space Dimensions

All hatchback cargo dimensions are to be taken with the front seat in full down and rear position, and the rear seat folded down. The hatchback door is in the closed position. (For electrically adjusted seats, see the manufacturer's specifications for Design "H" Point).

- L208 CARGO LENGTH AT FRONT SEATBACK HEIGHT. The minimum horizontal dimension from the "X" plane tangent to the rearmost surface of the driver's seatback to the inside limiting interference of the hatchback door on the vehicle zero "Y" plane.
- L209 CARGO LENGTH AT FLOOR-FRONT-HATCHBACK. The minimum horizontal dimension measured at floor level from the rear of the front seatback to the normal limiting interference of the hatchback door on the vehicle zero "Y" plane.
- L210 CARGO LENGTH AT SECOND SEATBACK HEIGHT-HATCHBACK. The minimum dimension measured from the "X" plane tangent to the rearmost surface of second seatback or the load floor which is stowed at least one half of the H198 dimension height above the rear load floor, to the rearmost inside limiting interference on the zero "Y" plane.
- L211 CARGO LENGTH AT FLOOR-SECOND HATCHBACK. The minimum horizontal dimension measured at floor level from the rear of the second seatback or load floor panel to the normal limiting interference of the hatchback door on the vehicle zero "Y" plane.
- H197 FRONT SEATBACK TO LOAD HEIGHT. The dimension measured vertically from the horizontal tangent to the top of the seatback to the undepressed floor covering.
- H198 SECOND SEATBACK TO LOAD FLOOR HEIGHT: The dimension measured vertically from the second seat back to the undepressed floor covering.
- V3 HATCHBACK.
Measured in inches:

$$\frac{L208 + L209}{2} \times W4 \times H197 = \text{ft}^3$$
 Measured in mm:

$$\frac{L208 + L209}{2} \times W4 \times H197 = \text{m}^3 \text{ (cubic meter)}$$
- V4 HIDDEN LUGGAGE CAPACITY-REAR OF FRONT SEAT. The total volumes of individual pieces of one set of standard luggage stowed in any hidden cargo area below the load floor rear of the front seat.
- V11 HATCHBACK CARGO VOLUME INDEX. Usable luggage (one (1) stand and luggage set) below floor:
Measured in inches:

$$\frac{L210 + L211}{2} \times W4 \times H198 = \text{ft}^3$$
 Measured in mm:

$$\frac{L210 + L211}{2} \times W4 \times H198 = \text{m}^3 \text{ (cubic meter)}$$

MVMA Specifications Form

Passenger Car

METRIC (U.S. Customary)

Interior Car And Body Dimensions – Key Sheet

Dimensions Definitions

- L-41 BACK ANGLE-SECOND. The angle measured between a vertical line through the SgRP-second and the torso line.
- L43 HIP ANGLE-SECOND. The angle measured between torso line and thigh centerline.
- L45 KNEE ANGLE-SECOND. The angle measured between thigh centerline and lower leg centerline.
- L47 FOOT ANGLE-SECOND. The angle measured between the lower leg centerline and a line tangent to the ball and heel of the three-dimensional devices bare foot flesh line (Reference J826).
- L48 KNEE CLEARANCE-SECOND. The minimum dimension measured from the knee pivot center to the back of the front seatback minus 51 mm (2.0 in.).
- L50 SgRP COUPLE DISTANCE-SECOND. The dimension measured horizontally from the driver SgRP-front to the SgRP-second.
- L51 MINIMUM EFFECTIVE LEG ROOM-SECOND. The dimension measured along a line from the ankle pivot center to the SgRP-second plus 254mm (10.0 in.).
- W4 SHOULDER ROOM-SECOND. The minimum dimension measured laterally between door or quarter trimmed surfaces on the "X" plane through the SgRP-second at height between 254-406 mm (10.0-16.0 in.) above the SgRP-second, excluding the door assist straps and attaching parts.
- W6 HIP ROOM-SECOND. Measured in the same manner as W5.
- H31 SgRP-SECOND TO HEEL. The dimension measured vertically from the SgRP-second to the two dimensional device heel point on the depressed floor covering.
- H38 HEADLINING TO ROOF PANEL-SECOND. The dimension measured from the intersection of the headlining and the extended effective head room line normally to the roof sheet metal.
- H51 UPPER BODY OPENING TO GROUND-SECOND. The dimension measured vertically from the trimmed body opening to the ground on the "X" plane 330 mm (13.0 in.) forward of the SgRP-second.
- H63 EFFECTIVE HEAD ROOM-SECOND. The dimension measured along a line 8 deg. rear of vertical from the SgRP to the headlining, plus 102 mm (4.0 in.).
- H73 FLOOR COVERING-DEPRESSED-SECOND. The dimension measured vertically from the heel point to the underbody sheet metal.
- PD2 PASSENGER DISTRIBUTION-SECOND.

Luggage Compartment Dimensions

- V1 USABLE LUGGAGE CAPACITY-Total of volumes of individual pieces of standard luggage set plus H-boxes stowed in the luggage compartment in accordance with the procedure described in paragraph 8.2 of SAE-J1100a.
- H195 LIFTOVER HEIGHT. The dimension measured vertically from the luggage compartment lower opening at the zero "Y" plane to ground.

Interior Volumes (EPA Classification)

The Interior Volume Index is listed for each body style except two seaters. The interior volume index estimates the space in a car. It is based on four measurements – head room, shoulder room, hip room, and leg room – for the front and rear seats, plus trunk capacity. The interior volume index is an estimate of the size of the passenger compartment.

The Trunk Cargo Index is an estimate of the size of the trunk cargo space. In station wagons and hatchbacks it is an estimate of the space behind the second seat.

Station Wagon – Third Seat Dimensions

- L85 SgRP COUPLE DISTANCE-THIRD. The dimension measured horizontally from the SgRP-second to the SgRP-third.
- L86 EFFECTIVE LEG ROOM-THIRD. The dimension measured along a line from the ankle pivot center to the SgRP-third plus 254 mm (10.0 in.).
- L87 KNEE CLEARANCE-THIRD. The minimum dimension from the knee pivot center to the back of second seatback minus a constant of 51mm (2.0 in.). With rear-facing third seat, dimension is measured to closure.
- L88 BACK ANGLE-THIRD. Measured in the same manner as L41.
- L89 HIP ANGLE-THIRD. Measured in the same manner as L43.
- L90 KNEE ANGLE-THIRD. Measured in the same manner as L45.
- L91 FOOT ANGLE-THIRD. Measured in the same manner as L47.
- W85 SHOULDER ROOM-THIRD. Measured in the same manner as W4.
- W86 HIP ROOM-THIRD. Measured in the same manner as W5.
- H86 EFFECTIVE HEAD ROOM-THIRD. The dimension, measured along a line 8 deg. from the SgRP-third to the headlining rear of vertical plus a constant of 102 mm (4.0 in.).
- H87 SgRP-THIRD TO HEEL POINT.
- PD3 PASSENGER DIRECTION-THIRD.
- SD1 SEAT FACING DIRECTION-THIRD.

Station Wagon – Cargo Space Dimensions

- L200 CARGO LENGTH-OPEN-FRONT. The minimum dimension measured longitudinally from the back of the front seatback at the height of the undepressed floor covering to the rearmost point on the undepressed floor covering on the open tailgate or cargo surface if the rear closure is a conventional door type tailgate at the zero "Y" plane.
- L201 CARGO LENGTH-OPEN-SECOND. The dimension measured longitudinally from the back of the second seatback at the height of the undepressed floor covering to the rearmost point on the undepressed floor covering on the open tailgate or cargo floor surface if the rear closure is a conventional door type tailgate, at the zero "Y" plane.
- L202 CARGO LENGTH-CLOSED-FRONT. The minimum dimension measured horizontally from the back of the front seat at the height of the undepressed floor covering to the rearmost point on the undepressed floor covering on the closed tailgate or taildoor for station wagons, trucks and mpv's at the zero "Y" plane.
- L203 CARGO LENGTH-CLOSED-SECOND. The dimension measured horizontally from the back of the second seat at the height of the undepressed floor covering to the rearmost point on the undepressed floor covering on the closed tailgate or taildoor for station wagons, trucks and mpv's at the zero "Y" plane.
- L204 CARGO LENGTH AT BELT-FRONT. The minimum dimension measured horizontally from the back of the front seatback at the seatback top to the foremost normal surface of the closed tailgate or inside surface of the cab backpanel at the height of the belt, on the zero "Y" plane.
- L205 CARGO LENGTH AT BELT-SECOND. The minimum dimension measured horizontally from the back of the second seatback at the seatback top to the foremost normal surface of the closed tailgate at the height of the belt, on the zero "Y" plane.
- W201 CARGO WIDTH-WHEELHOUSE. The minimum dimension measured laterally between the trimmed wheelhouseings at floor level. For any vehicle not trimmed, measure to the sheet metal.

MVMA Specifications Form

Passenger Car

METRIC (U.S. Customary)

Index

Subject	Page No.	Subject	Page No.
Aerodynamics	22	Lamps and Headlamp Shape	24
Alternator	16	Legroom	21, 22
Automatic Transmission/Transaxle	8, 9	Lengths - Car and Body	20
Axis, Steering	14	Leveling, Suspension	11
Axle, Drive, Front, Rear	2, 9, 10	Lifters, Valve	4
Axle Shafts	10	Linings - Clutch, Brake	8, 12
Battery	16	Lubrication - Engine Transmission/Transaxle	4, 8, 9
Body and Miscellaneous Information	17	Luggage Compartment	21
Brakes-Parking, Service	12, 13	Mass	25, 26
Camber	15	Models	1
Camshaft	3	Motor Starting	16
Capacities		Muffler	7
Cooling System	5	Passenger Capacity	1
Fuel Tank	6	Passenger Mass Distribution	25
Lubricants		Pistons	3
Engine Crankcase	4	Power Brakes	12
Transmission Transaxle	8, 9	Power, Engine	2
Rear Axle	10	Power Steering	14
Car Models	1	Power Teams	2
Car and Body Dimensions		Propeller Shaft, Universal Joints	10
Width	20	Pumps - Fuel	6
Length	20	Water	5
Height	20	Radiator - Cap, Hoses, Core	5
Ground Clearance	20	Ratios - Axle, Transaxle	2, 9
Front Compartment	21	Compression	2
Rear Compartment	21	Steering	14
Luggage Compartment	21	Transmission Transaxle	2, 8, 9
Station Wagon - Third Seat	22	Rear Axle	2, 9, 10
Station Wagon - Cargo Space	22	Regulator - Alternator	16
Hatchback - Cargo Space	22	Restraint System	18
Carburetor	2, 6	Rims	13
Caster	15	Rods - Connecting	4
Clutch, Automatic	6	Scrub Radius	14
Clutch - Pedal Operated	8	Seats	17
Oil, Ignition	16	Shock Absorbers, Front & Rear	11
Connecting Rods	4	Spark Plugs	16
Convenience Equipment	19	Speedometer	15
Cooling System	5	Springs - Front & Rear Suspension	11
Crankshaft	4	Stabilizer (Sway Bar) - Front & Rear	11
Cylinders and Cylinder Head	3	Starting System	16
Diesel Information	4	Steering	14
Dimension Definitions		Suppression - Ignition, Radio	16
Key Sheet - Exterior	27, 30, 31	Suspension - Front & Rear	11
Key Sheet - Interior	28, 29, 31, 32, 33	Tail Pipe	7
Electrical System	15, 16	Theft Protection	19
Emission Controls	7	Thermostat, Cooling	5
Engine - General		Tires	13
Bore, Stroke, Type	3	Toe-In	15
Compression Ratio	2	Torque Converter	9
Displacement	2, 3	Torque - Engine	2, 8, 9
Firing Order, Cylinder Numbering	3	Transaxle	9
General Information, Power & Torque	2	Transmission - Types	2, 8, 9
Intake System	4	Transmission - Automatic	2, 8, 9
Power Teams	2	Transmission - Manual	2, 8, 9
Exhaust System	7	Transmission - Ratios	2, 9
Equipment Availability, Convenience	19	Tread	20
Fan, Cooling	5	Trunk Cargo Load	1
Fiducial Marks	23	Trunk Luggage Capacity	21
Filters - Engine Oil, Fuel System	4	Turning Diameter	14
Frame	17	Utilized Construction	17
Front Suspension	11	Universal Joints, Propeller Shaft	10
Front Wheel Drive Unit	10	Valve System	4
Fuel System	6	Voltage Regulator	16
Fuel Injection	6	Water Pump	5
Fuel Tank	6	Weights	25, 26
Glass	18	Wheel Alignment	15
Headroom - Body	21, 22	Wheelbase	20
Heights - Car and Body	20	Wheels & Tires	13
Horns	15	Wheel Spindle	14
Horsepower - Brake	2	Widths - Car and Body	20
Ignition System	16	Windshield	18
Inflation - Tires	13	Windshield Wiper and Washer	15
Interior Volumes	21		
Instruments	15		

**MVMA Specifications Form
Passenger Car**

Car Line _____
Model Year _____ Issued _____ Revised (•) _____

METRIC (U.S. Customary)

SUPPLEMENTAL PAGE
