



1987
CHEVROLET
NOVA

1987 NOVA



1987 Nova 4-Door Notchback Sedan

NOVA
4-Door Notchback Sedan 1SK19
5-Door Hatchback Sedan 1SK68

PASSENGER CAPACITY
All models 5

NEW FEATURES

- Exterior appearance changes include body-color bumpers with dual tape stripes on CL-equipped cars.
- Wide body side moldings with stripes included with CL.
- Black bumpers with silver stripes and narrow body side moldings standard.
- New tail lamps on all models.
- New full wheel covers and aluminum wheels for Nova CL.
- Interiors feature fabric and stitch pattern revisions for seats and door trim on all models.
- Model lineup is carried over with Nova 4-Door Notchback Sedan and Nova 5-Door Hatchback Sedan.
- Rear defogger now a standard feature.
- Two new exterior colors and one new two-tone choice.

STANDARD FEATURES

- Transverse-mounted 1.6 Liter Overhead Cam 4-Cyl. Engine.
- 5-speed manual transmission with fourth and fifth gear overdrive.
- Front drive.
- Power front disc/rear drum brake system.
- P155/BOR-13 all-seasons steel-belted radial ply blackwall tires.
- Temporary spare tire.
- MacPherson-strut front and rear suspension.
- Low-pressure gas rear shock absorbers.
- AM radio.
- Rack-and-pinion steering.
- Unitized construction.
- 5-MPH bumpers.
- Cold weather package.
- Center high-mounted stop lamp.

EQUIPMENT AVAILABILITY

	4-Door Sedan	5-Door H/B	4-Door Sedan CL	5-Door H/B CL
Tinted glass	S	S	S	S
Body side molding	S	S	S	S
Body side pin striping	NA	NA	S	S
Black, remote, patch-mounted OSRV mirror	S	S	S	S
Rear window defogger	S	S	S	S
Remote trunk lid opener	NA	NA	S	S
Remote fuel filler door opener	NA	NA	S	S
Quad rectangular headlamps	S	S	S	S
Black applique panel on trunk/hatch	NA	NA	S	S
Body-color door frames	S	S	NA	NA
Black painted door uppers	NA	NA	S	S
Passenger assist grips	NA	NA	S	S
Cut-pile carpeting	S	S	S	S
Molded fabric headliner	S	S	S	S
Passenger side visor vanity mirror	NA	NA	S	S
Day/night inside rearview mirror	S	S	S	S
Rear compartment security cover (H/B)	NA	S	NA	S
Luggage area lamp	NA	NA	S	S
Lumbar support and vertical adjustment on driver's seat	NA	NA	S	S
Reclining front bucket seats	S	S	S	S
Flat fold-down rear seat	NA	S	NA	S
Fully upholstered door trim panels with cloth inserts	S	S	S	S
Custom Cloth upholstery	NA	NA	S	S
Automatic transmission	EC	EC	EC	EC
Side window defoggers	S	S	S	S
Windshield wipers with mist cycle	S	S	S	S
Tilt steering column	NA	NA	S	S

S - Standard EC - Extra Cost NA - Not Available

Refer to Dealer Order Guide for option availability and application.

PRODUCT FEATURES

Standard Nova interior

Center: 1987 Nova Notchback Sedan - GE Custom interior

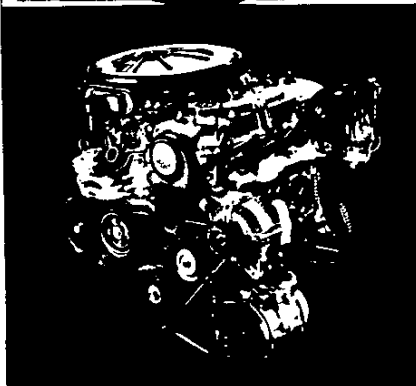
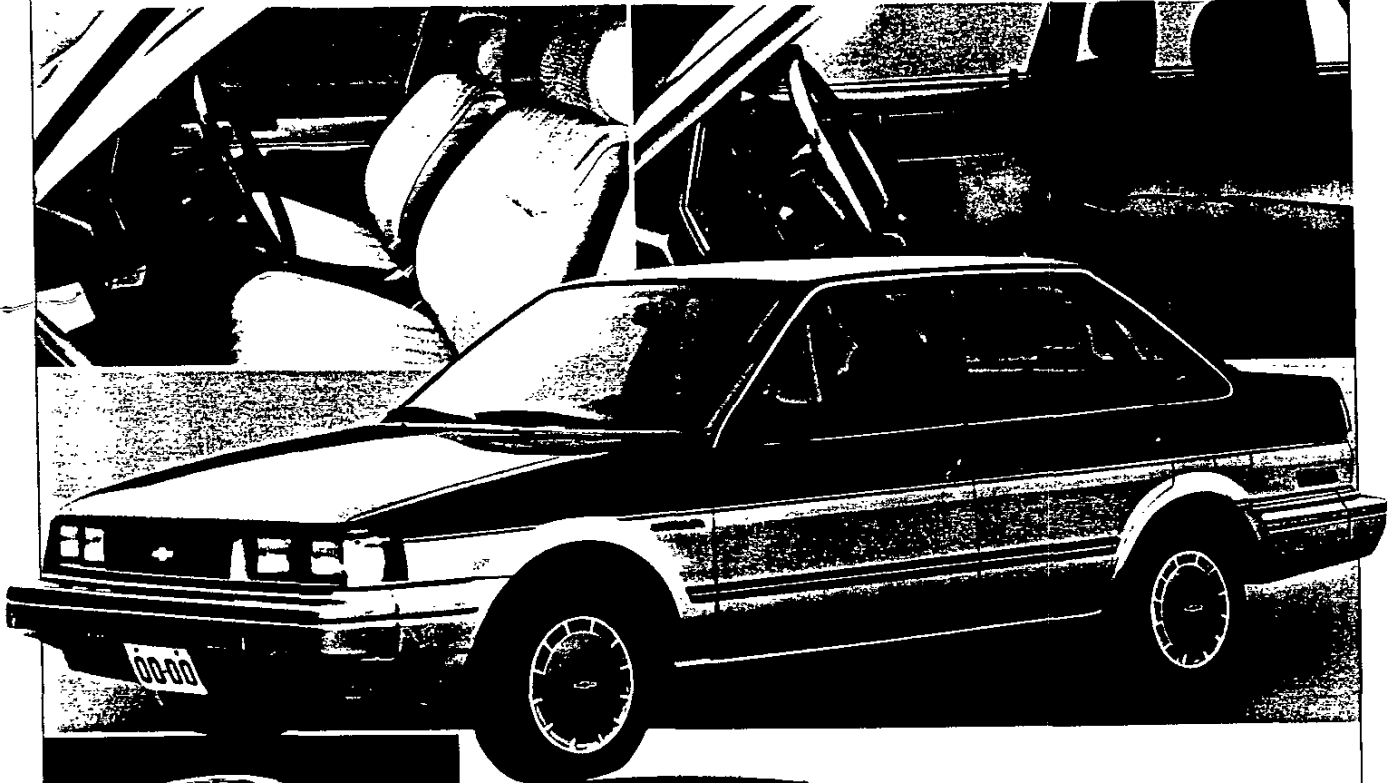

Nova 1.6 Liter L4 engine

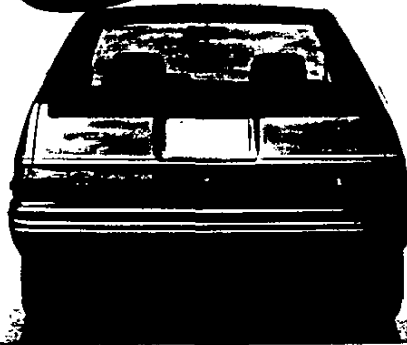

New tail lamps and bumper-level hatch door opening



Notchback rear treatment with bumper-level deck opening

Refer to Dealer Order Guide for option availability and application.

POPULAR MODELS & COLORS

1987 EXTERIOR COLORS

- 11 - White
- 13 - Silver Metallic
- 22 - Light Blue Metallic
- 26 - Dark Blue
- 33 - Light Brown Metallic*
- 65 - Medium Brown Metallic*
- 75 - Red
- 84 - Medium Gray Metallic

*New for 1987

POPULAR SELLING EXTERIOR COLORS

(MODEL YEAR '86 THROUGH FEBRUARY)

1. 84 - Medium Gray Metallic; 15.5%
2. 22 - Light Blue Metallic; 15.3%
3. 76 - Dark Red Metallic; 15.1%
4. 26 - Dark Blue; 14.0%
5. 13 - Silver Metallic; 10.0%
6. 11 - White; 9.5%

MODEL MIX

(MODEL YEAR '86 THROUGH FEBRUARY)

- Nova 4-Door Notchback Sedan (1SK19); 73%
- Nova 5-Door Hatchback Sedan (1SK68); 27%

All illustrations and specifications in this brochure are based on the latest product information available at the time of publication approval. The right is reserved to make changes at any time, without notice, in colors, materials, specifications and models, and also to discontinue models. Chevrolet Motor Division, General Motors Corporation, Warren, Michigan 48090.

Litho in U.S.A.



4724/486

INTERIORS

NOVA CL

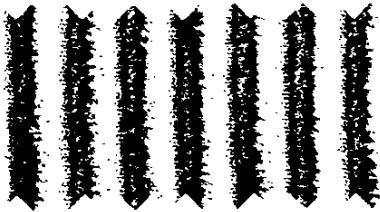

Custom Cloth seat trim available in Dark Blue, Brown or Medium Gray.

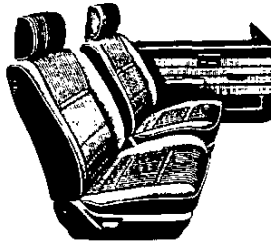

Custom Cloth Reclining Bucket Seats with adjustable lumbar support and vertical adjustment on driver's seat.

NOVA

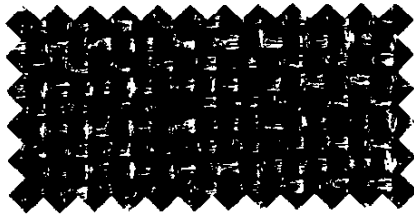

Cloth seat trim available in Dark Blue, Brown or Medium Gray.

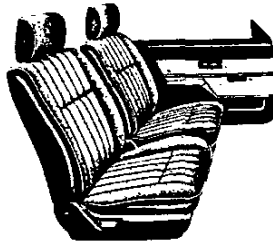

Cloth Reclining Bucket Seats with adjustable head restraints.

CL BODY PIN STRIPING

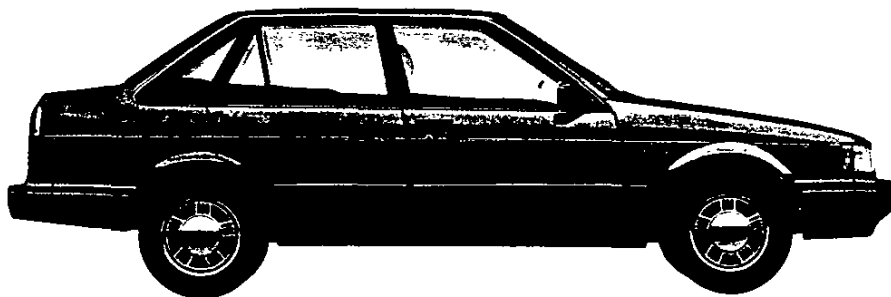

Color-keyed pinstripe on body sides and fenders keyed to exterior/interior color

combinations. Standard on Nova CL, included with Custom Two-Tone.

CUSTOM TWO-TONE PAINT

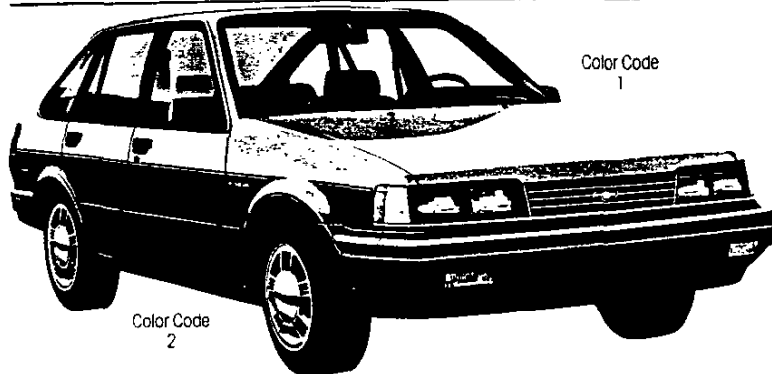

Color Code 1

Color Code 2

Two-Tone exterior with accent color on lower body sides, fenders and bumpers. Color now breaks above body belt line with

enhancing body side stripe. Available with Nova CL only.

WHEEL TRIM

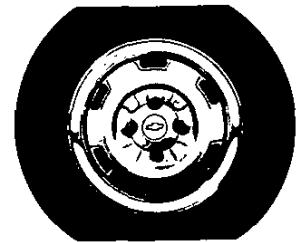

Standard argent-color Styled Steel Wheel with center cap and bright trim ring.

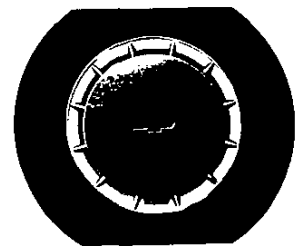

Available Nova CL Full Wheel Cover.



Available Nova CL Aluminum Wheel.

Refer to Dealer Order Guide for option availability and application.

ALPHABETICAL OPTION INDEX

(Not for ordering purposes)

Option Number	Description
B34	FLOOR COVERING: Carpeted Mats, Color-Keyed, Front Only
B35	FLOOR COVERING: Carpeted Mats, Color-Keyed, Rear Only

NOVA NOTCHBACK SEDAN

COLOR AND TRIM SELECTION

PLEASE NOTE:



AS INDICATED ON THE SMALL CARS QUICK-SPEC WORKSHEET, PRIMARY AND SECONDARY EXTERIOR/INTERIOR COLOR CHOICES MUST BE SPECIFIED. THE EXTERIOR/INTERIOR COLOR COMBINATIONS SHOWN BELOW ARE THE ONLY COMBINATIONS THAT ARE AVAILABLE. NO SUBSTITUTIONS ARE PERMITTED.

CONCERNING SECONDARY EXTERIOR/INTERIOR COLOR CHOICE: ANY SPECIFIC AVAILABLE COLOR AND TRIM COMBINATION MAY BE INDICATED AS A SECONDARY CHOICE. AS A FURTHER ALTERNATIVE, SECONDARY CHOICE CAN REFLECT A WILLINGNESS TO ACCEPT A VEHICLE WITH ANY AVAILABLE COLOR AND TRIM COMBINATION. (SEE ALTERNATIVE SECONDARY COLOR AND TRIM BELOW.)

Interior-Trim Color		Dk Blue	Brown	Med Gray
MODEL	SEAT TYPE			
15K19	Cloth Bucket + CL Custom Cloth Bucket	A002 # B002	AWW2 # BWW2	A002 # B002

*Available only with Quick-Specs NVA6, NVA7 and NVA8

CUSTOM TWO-TONE PAINT—Available only with Nova CL (QS NVA6, NVA7 and NVA8 only)

Exterior Paint Color	Color Code 1	Color Code 2	Dk Blue	Brown	Med Gray
Brown, Light (Met)/Med Brown (Met)	33	65		X	
Gray, Med (Met)/Silver (Met)	84	13			X

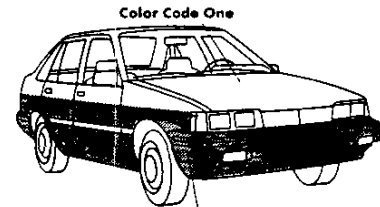

Color Code One
Color Code Two
CUSTOM TWO-TONE

SOLID PAINT APPLICATION

Color	Code 1	Code 2	Dk Blue	Brown	Med Gray
Blue, Dark	26	26	X		
Blue, Light (Met)	22	22	X		
Brown, Light (Met)	33	33		X	
Brown, Medium (Met)	65	65		X	
Gray, Medium (Met)	84	84			X
Red	75	75			X
Silver (Met)	13	13			X
White	11	11	X		

ALTERNATIVE SECONDARY COLOR AND TRIM

IF ONE OF THE SPECIFIC COLOR/TRIM COMBINATIONS ABOVE IS NOT SELECTED AS A SECONDARY CHOICE, ONE OF THE BROADER ALTERNATIVES SHOWN BELOW MAY BE SPECIFIED.

Exterior Paint Color	Color Code 1	Color Code 2	TRIM
#Any Two-tone	AN	Y1	ANY1
Any Solid	AN	Y2	ANY2
Any Paint	AN	Y3	ANY3

*Available only with Quick-Specs NVA6, NVA7 and NVA8

CL PIN STRIPING COLOR WITH CUSTOM TWO-TONE PAINT

Exterior Paint Color	Color Code 1	Color Code 2	TRIM
Brown, Light (Met)/Med Brown (Met)	33	65	Red/Lt Brown
Gray, Med (Met)/Silver (Met)	84	13	Red/Med Gray

CL PIN STRIPING COLOR WITH SOLID PAINT APPLICATION

Color	Code 1	Code 2	TRIM
Blue, Dark	26	26	Med Silver/Blue
Blue, Light (Met)	22	22	Med Silver/Blue
Brown, Light (Met)	33	33	Med Brown/Red
Brown, Medium (Met)	65	65	Lt Brown/Red
Gray, Medium (Met)	84	84	Med Silver/Red
Red	75	75	Silver/Red
Silver (Met)	13	13	Med Blue/Gray
White	11	11	Med Silver/Blue

POWER TEAMS (Refer to next page for option availability and application)

ENGINE OPTION CONDITION	AXLE RATIO	
	3.42	3.72
WITH NA5 STANDARD EMISSIONS		
LC9 5-SPEED MANUAL TRANSMISSION	—	Std
AUTOMATIC TRANSMISSION	Std	—
WITH YF5 CALIFORNIA EMISSIONS		
LC9 5-SPEED MANUAL TRANSMISSION	—	Std
AUTOMATIC TRANSMISSION	Std	—

NOVA NOTCHBACK SEDAN

REFER WEEKLY STOPS/LATEST UPDATE

MODEL

1SK19 Nova 4-Door Notchback Sedan

ENGINE: MUST ORDER (See Power Teams)

STANDARD EMISSION EQUIPMENT—REQUIRES NA5

(Also Satisfies High Altitude Requirements)

LC9 1.6 Liter 2 BBL L4

CALIFORNIA EMISSION EQUIPMENT—REQUIRES YF5

LC9 1.6 Liter 2 BBL L4

EMISSION SYSTEMS: MUST ORDER ONE (See Above)

NA5 Standard Emission Equipment

YF5 California Emission Requirements

QUICK-SPEC



NOTE: AS INDICATED ON THE SMALL CARS QUICK-SPEC WORKSHEET, A PRIMARY AND SECONDARY QUICK-SPEC MUST BE INDICATED WHEN ORDERING.

ADDITIONS TO, AND DELETIONS FROM QUICK-SPECS ARE NOT PERMITTED. FEATURES BELOW ARE AVAILABLE ONLY IN THE QUICK-SPECS SHOWN.

	NOVA					*NOVA CL		
	N V A 1	N V A 2	N V A 3	N V A 4	N V A 5	N V A 6	N V A 7	N V A 8
NOVA OPTION PACKAGE 1	x							
NOVA OPTION PACKAGE 2		x						
NOVA OPTION PACKAGE 3			x					
NOVA OPTION PACKAGE 4				x				
NOVA OPTION PACKAGE 5					x			
NOVA CL OPTION PACKAGE 1						x		
NOVA CL OPTION PACKAGE 2							x	
NOVA CL OPTION PACKAGE 3								x
Transmission: 5-Speed Manual	x		x				x	
Transmission: Automatic		x		x	x	x		x
Radio, AM	x	x						
Tires, P155/80 R-13 All-Seasons Steel Belted Radial Ply								
Blackwall	x	x	x	x	x			
#Defogger Credit, Rear Window: Electric								
Steering, Power		x	x	x	x	x	x	x
Air Conditioning				x	x	x	x	x
Headlamps, Halogen: High and Low Beam						x	x	x
Mirrors: Outside, LH Remote and RH Manual						x	x	x
Radio, Electronically Tuned AM/FM Stereo w/Seek-Scan and Digital Clock				x	x	x		
Tires, P175/70 R-13 All-Seasons Steel Belted Radial Ply								
Blackwall						x	x	x
Radio, Electronically Tuned AM/FM Stereo Radio w/Seek-Scan, Stereo Cassette Tape and Digital Clock							x	x
Speed Control, Electronic: With Resume Speed							x	x
Wheels, Aluminum							x	
W/S Wiper System: Intermittent							x	x
Door Lock System, Power								x
Windows, Power								x

#Defogger Deleted from Quick-Spec NVA5

*CUSTOM CL FEATURE PACKAGE (Available Only When B**2 Custom Cloth Bucket Is Specified.)

Includes:

Custom Cloth Interior
Tilt Steering Column
Driver's Seat with Lumbar Support and Vertical Adjustment
Console with Storage Box and Armrest

Body-Colored Bumpers
Remote Trunk Lid and Fuel Filler Door Opener
Luggage Compartment
Floor Carpet and Lamp
Bright Roof Drip and Door Belt Moldings

Full Wheel Covers (N/A Q.S. NVA7)
Black Rear Applique
Wide Body Side Moldings
Body Side Stripes
Right Side Visor Vanity Mirror
Soft Steering Wheel
Passenger Assist Grips



OPTIONS AVAILABLE. PLEASE REVIEW OPTION RESTRICTIONS BEFORE ORDERING. ADDITIONS MUST BE SHOWN AS "+" ON ORDERS

OPTION

FLOOR COVERING:

B34 — Carpeted Mats, Color-Keyed, Front Only
B35 — Carpeted Mats, Color-Keyed, Rear Only

NOVA HATCHBACK SEDAN

COLOR AND TRIM SELECTION

PLEASE NOTE:



AS INDICATED ON THE SMALL CARS QUICK-SPEC WORKSHEET, PRIMARY AND SECONDARY EXTERIOR/INTERIOR COLOR CHOICES MUST BE SPECIFIED. THE EXTERIOR/INTERIOR COLOR COMBINATIONS SHOWN BELOW ARE THE ONLY COMBINATIONS THAT ARE AVAILABLE. NO SUBSTITUTIONS ARE PERMITTED.

CONCERNING SECONDARY EXTERIOR/INTERIOR COLOR CHOICE:
ANY SPECIFIC AVAILABLE COLOR AND TRIM COMBINATION MAY BE INDICATED AS A SECONDARY CHOICE. AS A FURTHER ALTERNATIVE, SECONDARY CHOICE CAN REFLECT A WILLINGNESS TO ACCEPT A VEHICLE WITH ANY AVAILABLE COLOR AND TRIM COMBINATION. (SEE ALTERNATIVE SECONDARY COLOR AND TRIM BELOW.)

Interior-Trim Color		Dk. Blue	Brown	Med. Gray
MODEL	SEAT TYPE			
1SK68	Cloth Bucket * CL Custom Cloth Bucket	ADD2 #B002	AWW2 #BWW2	A002 #B002

#Available only with Quick-Specs NHA6, NHA7 and NHA8

CUSTOM TWO-TONE PAINT—Available only with Nova CL (QS NHA6, NHA7 and NHA8 only)

Exterior Paint Color	Color Code 1	Color Code 2	Dk. Blue	Brown	Med. Gray
Brown, Light (Met)/Med Brown (Met)	33	65		X	
Gray, Med (Met)/Silver (Met)	84	13			X

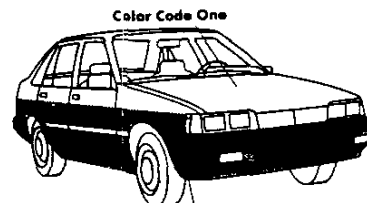

Color Code One
Color Code Two
CUSTOM TWO-TONE

SOLID PAINT APPLICATION

Color	Code 1	Code 2	Dk. Blue	Brown	Med. Gray
Blue, Dark	26	26	X		
Blue, Light (Met)	22	22	X		
Brown, Light (Met)	33	33		X	
Brown, Medium (Met)	65	65		X	
Gray, Medium (Met)	84	84			X
Red	75	75			X
Silver (Met)	13	13			X
White	11	11	X		

ALTERNATIVE SECONDARY COLOR AND TRIM

IF ONE OF THE SPECIFIC COLOR/TRIM COMBINATIONS ABOVE IS NOT SELECTED AS A SECONDARY CHOICE, ONE OF THE BROADER ALTERNATIVES SHOWN BELOW MAY BE SPECIFIED.

Exterior Paint Color	Color Code 1	Color Code 2	TRIM
#Any Two-Tone	AN	Y1	ANY1
Any Solid	AN	Y2	ANY2
Any Paint	AN	Y3	ANY3

#Available only with Quick-Specs NHA6, NHA7 and NHA8

CL PIN STRIPING COLOR WITH CUSTOM TWO-TONE PAINT

Exterior Paint Color	Color Code 1	Color Code 2	TRIM
Brown, Light (Met)/Med Brown (Met)	33	65	Red/Lt Brown
Gray, Med (Met)/Silver (Met)	84	13	Red/Med Gray

CL PIN STRIPING COLOR WITH SOLID PAINT APPLICATION

Color	Code 1	Code 2	TRIM
Blue, Dark	26	26	Med Silver/Blue
Blue, Light (Met)	22	22	Med Silver/Blue
Brown, Light (Met)	33	33	Med Brown/Red
Brown, Medium (Met)	65	65	Lt Brown/Red
Gray, Medium (Met)	84	84	Med Silver/Red
Red	75	75	Silver/Red
Silver (Met)	13	13	Med Blue/Gray
White	11	11	Med Silver/Blue

POWER TEAMS (Refer to next page for option availability and application)

ENGINE OPTION CONDITION		AXLE RATIO	
		3.42	3.72
WITH NA5 STANDARD EMISSIONS			
LC9	5-SPEED MANUAL TRANSMISSION	—	Std
	AUTOMATIC TRANSMISSION	Std	—
WITH YF5 CALIFORNIA EMISSIONS			
LC9	5-SPEED MANUAL TRANSMISSION	—	Std
	AUTOMATIC TRANSMISSION	Std	—

NOVA HATCHBACK SEDAN

REFER WEEKLY STOPS/LATEST UPDATE

MODEL

1SK68 Nova 5-Door Hatchback Sedan

ENGINE: MUST ORDER (See Power Teams)

STANDARD EMISSION EQUIPMENT—REQUIRES NA5
(Also Satisfies High Altitude Requirements)

LC9 1.6 Liter 2 BBL L4

CALIFORNIA EMISSION EQUIPMENT—REQUIRES YF5

LC9 1.6 Liter 2 BBL L4

EMISSION SYSTEMS: MUST ORDER ONE (See Above)

NA5 Standard Emission Equipment

YF5 California Emission Requirements

QUICK-SPEC



NOTE: AS INDICATED ON THE SMALL CARS QUICK-SPEC WORKSHEET, A PRIMARY AND SECONDARY QUICK-SPEC MUST BE INDICATED WHEN ORDERING.

ADDITIONS TO, AND DELETIONS FROM QUICK-SPECS ARE NOT PERMITTED. FEATURES BELOW ARE AVAILABLE ONLY IN THE QUICK-SPECS SHOWN.

	NOVA					*NOVA CL		
	NH A 1	NH A 2	NH A 3	NH A 4	NH A 5	NH A 6	NH A 7	NH A 8
NOVA OPTION PACKAGE 1	x							
NOVA OPTION PACKAGE 2		x						
NOVA OPTION PACKAGE 3			x					
NOVA OPTION PACKAGE 4				x				
NOVA OPTION PACKAGE 5					x			
NOVA CL OPTION PACKAGE 1						x		
NOVA CL OPTION PACKAGE 2							x	
NOVA CL OPTION PACKAGE 3								x
Transmission: 5-Speed Manual	x		x				x	
Transmission: Automatic		x		x	x	x		x
Radio, AM	x	x						
Tires, P155/80 R-13 All-Seasons Steel Belted Radial Ply Blackwall	x	x	x	x	x			
#Defogger Credit, Rear Window: Electric					x			
Steering, Power		x	x	x	x	x	x	x
Air Conditioning			x	x	x	x	x	x
Headlamps, Halogen: High and Low Beam						x	x	x
Mirrors: Outside, LH Remote and RH Manual						x	x	x
Radio, Electronically Tuned AM/FM Stereo w/Seek-Scan and Digital Clock			x	x	x	x		
Tires, P175/70 R-13 All-Seasons Steel Belted Radial Ply Blackwall						x	x	x
Wheels, Aluminum						x		x
Radio, Electronically Tuned AM/FM Stereo Radio w/Seek-Scan, Stereo Cassette Tape and Digital Clock							x	x
Speed Control, Electronic: With Resume Speed							x	x
Window Wiper/Washer, Rear							x	x
W/S Wiper System: Intermittent							x	x
Door Lock System, Power								x
Windows, Power								x

#Defogger Deleted from Quick-Spec NHA5

*CUSTOM CL FEATURE PACKAGE (Available Only When B**2 Custom Cloth Bucket Is Specified.)

Includes:

Custom Cloth Interior
Tilt Steering Column
Driver's Seat with Lumbar Support and Vertical Adjustment
Console with Storage Box and Armrest

Body-Colored Bumpers
Remote Trunk Lid and Fuel Filler Door Opener
Luggage Compartment
Floor Carpet and Lamp
Bright Roof Drip and Door Belt Moldings

Full Wheel Covers (N/A Q.S. NHA6 and NHA8)
Black Rear Applique
Wide Body Side Moldings
Body Side Stripes
Right Side Visor Vanity Mirror
Soft Steering Wheel
Passenger Assist Grips



OPTIONS AVAILABLE. PLEASE REVIEW OPTION RESTRICTIONS BEFORE ORDERING. ADDITIONS MUST BE SHOWN AS "+" ON ORDERS

OPTION

FLOOR COVERING:

B34 — Carpeted Mats, Color-Keyed, Front Only
B35 — Carpeted Mats, Color-Keyed, Rear Only

NOTES



MANUFACTURERS MOTOR VEHICLE SPECIFICATIONS

METRIC (U.S. Customary)

Passenger Car

1987

Manufacturer	Toyota Motor Corporation 4-18 Koraku 1-Chome Bunkyo-Ku, Tokyo, Japan	Car Line	NOVA	
Mailing Address	Chevrolet-Pontiac-Canada Group Engineering Center General Motors Corporation 30003 Van Dyke Warren, MI 48090-9060	Issued	SEPTEMBER, 1986	Revised

Questions concerning these specifications should be directed to the manufacturer whose address is shown above.

The information contained herein is prepared, distributed by, and is solely the responsibility of the automobile manufacturing company to whose products it relates. This specification form was developed by the automobile manufacturing companies under the auspices of the Motor Vehicle Manufacturers Association of the United States, Inc.

The General Specifications herein are those in effect at date of compilation and are subject to change without notice by the manufacturer.

Blank Forms Provided by Technical Affairs Division

m v m a
Motor Vehicle Manufacturers Association
of the United States, Inc.

Table of Contents

1	Car Models
2	Power Teams
3-6	Engine
4	Lubrication System
4	Diesel Information
5	Cooling System
6	Fuel System
7	Vehicle Emission Control
7	Exhaust System
8-10	Transmission, Axles and Shafts
11	Suspension-Front and Rear
12-13	Brakes
13	Tires and Wheels
14-15	Steering
15-16	Electrical
17	Body – Miscellaneous Information
18	Restraint System
18	Frame
18	Glass
19	Convenience Equipment
20-22	Car and Body Dimensions
23	Vehicle Fiducial Marks
24	Lamps and Headlamps
25	Vehicle Mass (Weight)
26	Optional Equipment Differential Mass (Weight)
27-33	Car and Body Dimensions Definitions - Key Sheets
34	Index

NOTE:

1. This form uses both SI metric units and U.S. Customary units. The metric unit of measure is presented first, and the U.S. Customary unit follows in parentheses.
2. **UNLESS OTHERWISE INDICATED:**
 - a. Specifications apply to standard models without optional equipment. Significant deviations are noted.
 - b. Nominal design dimensions are used throughout these specifications.
 - c. All linear dimensions are in millimeters (inches), and all mass (weight) specifications are in kilograms (pounds).
3. The General Specifications herein are those in effect at date of completion and are subject to change without notice by the manufacturer.
4. Additional Car and Body Dimensions (based in part on SAE J1100 "Motor Vehicle Dimensions") may be available from the manufacturer.

Car Line NOVA
 Model Year 1987 Issued _____ Revised (e) _____

Car Models

Model Description & Drive (FWD/RWD)	Introduction Date	Make, Car Line, Series, Body Type (Mfg's Model Code)	No. of Designated Seating Positions (Front/Rear)	Max. Trunk Cargo Load—Kilograms (Pounds)
4-Door Sedan Base		AE82L-FEMDCA	2/3	45 (100)
4-Door Sedan Base		AE82L-FEHDCA	2/3	45 (100)
4-Door Sedan CL		AE82L-FEMNCA	2/3	45 (100)
4-Door Sedan CL		AE82L-FEHNCA	2/3	45 (100)
5-Door Liftback Base		AE82L-FLMDCA	2/3	45 (100)
5-Door Liftback Base		AE82L-FLHDCA	2/3	45 (100)
5-Door Liftback CL		AE82L-FLMNCA	2/3	45 (100)
5-Door Liftback CL		AE82L-FLHNCA	2/3	45 (100)
4-Door Sedan Base		AE82L-FEMDCK	2/3	45 (100)
4-Door Sedan Base		AE82L-FEHDCK	2/3	45 (100)
4-Door Sedan CL		AE82L-FEMNCK	2/3	45 (100)
4-Door Sedan CL		AE82L-FEHNCK	2/3	45 (100)
5-Door Liftback Base		AE82L-FLMDCK	2/3	45 (100)
5-Door Liftback Base		AE82L-FLHDCK	2/3	45 (100)
5-Door Liftback CL		AE82L-FLMNCK	2/3	45 (100)
5-Door Liftback CL		AE82L-FLHNCK	2/3	45 (100)

Power Terms (Indicate whether standard or optional)
 SAE J1349 Net Bhp (brake horsepower) and net torque corrected to 77°F/25° C and 29.81 in. Hg/100 kPa atmospheric pressure.

SERIES AVAILABILITY	ENGINE					E x h a u s t S D	TRANSMISSION TRANSAXLE	AXLE RATIO (Std. Inst)
	Disc. Liters (in ³)	Cyls. (Barrels, Fl. etc.)	Comp. Ratio	SAE Net at RPM				
				kW (bhp)	Torque N·m (lb. ft.)			
		Barrels		kW/rpm	·m/rpm			
AE82L-FEMDCA	1.587	2	9.0	55/5200 <i>74 hp</i>	116/2800	S	5-Speed Manual	3.722
AE82L-FEHDCA	1.587	2	9.0	55/5200	116/2800	S	3-Speed Automatic	3.421
AE82L-FEMNCA	1.587	2	9.0	55/5200	116/2800	S	5-Speed Manual	3.722
AE82L-FEHNCA	1.587	2	9.0	55/5200	116/2800	S	3-Speed Automatic	3.421
AE82L-FLMDCA	1.587	2	9.0	55/5200	116/2800	S	5-Speed Manual	3.722
AE82L-FLHDCA	1.587	2	9.0	55/5200	116/2800	S	3-Speed Automatic	3.421
AE82L-FLMNCA	1.587	2	9.0	55/5200	116/2800	S	5-Speed Manual	3.722
AE82L-FLHNCA	1.587	2	9.0	55/5200	116/2800	S	3-Speed Automatic	3.421
AE82L-FEMDCK	1.587	2	9.0	55/5200	116/2800	S	5-Speed Manual	3.722
AE82L-FEHDCK	1.587	2	9.0	55/5200	116/2800	S	3-Speed Automatic	3.421
AE82L-FEMNCK	1.587	2	9.0	55/5200	116/2800	S	5-Speed Manual	3.722
AE82L-FEHNCK	1.587	2	9.0	55/5200	116/2800	S	3-Speed Automatic	3.421
AE82L-FLMDCK	1.587	2	9.0	55/5200	116/2800	S	5-Speed Manual	3.722
AE82L-FLHDCK	1.587	2	9.0	55/5200	116/2800	S	3-Speed Automatic	3.421
AE82L-FLMNCK	1.587	2	9.0	55/5200	116/2800	S	5-Speed Manual	3.722
AE82L-FLHNCK	1.587	2	9.0	55/5200	116/2800	S	3-Speed Automatic	3.421
				or 74 horsepower				

Engine Description/Car
 Engine Code

4A-LC

ENGINE - GENERAL

Type & description (inline, V, angle, etc. location, front, mid, rear, transverse, longitudinal, carb. carb. etc. front, wedge, pre-chamber, etc.)	Type = In-line Chamber = Wedge Location = Front (Transverse) Cam & valve = SOHC	
Manufacturer	TOYOTA Motor Corporation	
No. of cylinders	4	
Bore	81.0 mm	
Stroke	77.0 mm	
Bore spacing (C-L to C-L)	87.5 mm	
Cylinder block material & mass (kg (lbs.))	Gray cast iron	34.0 kg
Cylinder block deck height	191.0 mm	
Cylinder block length	391.5 mm	
Deck clearance (minimum) (above or below block)	0.00 mm	
Cylinder head material & mass (kg (lbs.))	Aluminum alloy	7.0 kg
Cylinder head volume (cm ³)	32.5	
Cylinder liner material	Gray cast iron	
Head gasket thickness (compressed)	1.20 mm	
Minimum combustion chamber total volume (cm ³)	49.9	
Cyl. no. system (front to rear)*	L. Bank	1-2-3-4
	R. Bank	-
Firing order	1-3-4-2	
Intake manifold material & mass (kg (weight, lbs.))	Aluminum alloy	1.5 kg
Exhaust manifold material & mass (kg (weight, lbs.))	Gray cast iron	5.8 kg
Recommended fuel (leadless, unleaded, diesel)	Unleaded	
Peak gross crank (R + M) 2	87	
Total gross engine mass (wt dry)**	114 kg (Manual), 105 kg (Automatic)	

Engine - Pistons

Material & mass, g (weight, oz.) - piston only	Aluminum alloy, 268 g
--	-----------------------

Engine - Camshaft

Location	Over head	
Material & mass (kg (weight, lbs.))	Gray cast iron 2.38 kg	
Drive type	Chain / belt	Belt
	Wash / pitch	19.05/9.525 mm

* Rear of engine - drive shaft. View from drive shaft end to determine left & right side of engine.
 ** Dressed engine mass (weight) includes the following:

Car Line NOVA
 Model Year 1987 Issued _____ Revised (*) _____

Engine Description-Carb.
 Engine Code

4A-LC

Engine - Valve System

Hydraulic lifters (ISS., OPL., NA)		N.A.
Valves	Number intake / exhaust	4/4
	Head O.D. intake / exhaust	36 mm / 31 mm

Engine - Connecting Rods

Material & mass (kg., weight, lbs.)	Carbon steel, 0.46 kg
-------------------------------------	-----------------------

Engine - Crankshaft

Material & mass (kg., weight, lbs.)	Spheroidal graphite cast iron	9.4 kg
End thrust taken by bearing (no.)	#3	
Number of main bearings	5	
Seal (material, one, two piece design, etc.)	Front	N.B.R., 1 piece
	Rear	N.B.R., 1 piece

Engine - Lubrication System

Normal oil pressure (kPa (psi) at engine rpm)	235 kPa 2000 rpm
Type of intake (floating, stationary)	Stationary
Oil filter system (full flow, part, other)	Full-flow
Capacity of crasse, less filter-when-L (qt.)	3.0L

Engine - Diesel Information

Diesel engine manufacturer	-	
Glow plug, current drain at 0°F	-	
Injector nozzle	Type	-
	Opening pressure (kPa (psi))	-
Pre-chamber design	-	
Fuel injection pump	Manufacturer	-
	Type	-
Fuel injection pump drive (belt, chain, gear)	-	
Supplementary vacuum source (type)	-	
Fuel heater (yes/no)	-	
Water separator, description (ISS., OPL.)	-	
Turbo manufacturer	-	
Oil cooler-type (oil to engine coolant, oil to ambient air)	-	
Oil filter	-	

Engine - Intake System

Turbo charger - manufacturer	N.A.
Super charger - manufacturer	N.A.
Charge cooler	N.A.

Engine Description/Car
 Engine Code

4A-LC

Engine - Cooling System

Coolant recovery system (std., opt., n.a.)		Std.
Coolant fill location (rad., some)		Radiator
Radiator cap relief valve pressure (kPa (psi))		88.3 kPa
Circulation thermostat	Type (choke, bypass)	Bypass type
	Starts to open at °C (°F)	82°
Water Pump	Type (centrifugal, other)	Centrifugal type
	GPM 1000 pump rpm	6.0 gal/min
	Number of pumps	1
	Drive (V-belt, other)	V-ribbed belt
	Bearing type	Sealed type, roller & ball bearing
	Impeller material	Steel
Housing material		Aluminum alloy
By-pass recirculation (type (water, air), std.)		External
Cooling system capacity	With heater—L (qt.)	6L
	With air cond.—L (qt.)	6L
	Opt. equipment (specify—L, qt.)	N.A.
Water jackets full length of cyl. (yes, no)		Yes
Water all around cylinder (yes, no)		No
Water jackets open at head face (yes, no)		No
Radiator core	Std., A/C, HD	Std., Opt. N.A.
	Type (cross-flow, etc.)	Vertical flow
	Construction (fin & tube mechanical, brazed, etc.)	Corrugated fin
	Material, mass (kg (wgt. lbs.))	Brass and copper, 3.7 kg (Manual) 4.3 kg (Automatic)
	Width	666 mm
	Height	325 mm
	Thickness	16 mm
Fins per inch		17 (Manual) 23 (Automatic)
Radiator end tank material		Resin
Fan	Std., elec., opt.	Electric type
	Number of blades & type (flex. cond. material)	5, solid
	Diameter & projected width	280 mm x 41 mm
	Ratio (fan to crankshaft rev.)	-
	Fan outlet type	-
	Drive type (direct, remote)	-
	RPM at idle (elec.)	1900
	Motor rating (wattage) (elec.)	50
	Motor switch (type & location) (elec.)	Water temperature, Water inlet housing
	Switch point (temp., pressure) (elec.)	90°C
	Fan arround (material)	Resin

Car Line NOVA
 Model Year 1987 Issued _____ Revised (e) _____

Engine Description/Carb.
 Engine Code

4A-LC

Engine - Fuel System (See supplemental page for details of Fuel Injection, Supercharger, Turbocharger, etc. if used)

Induction type: carburetor, fuel injection system, etc.		Carburetor	
Carburetor	Make	Aisan Industry Co., Ltd.	
	Choke (type)	Automatic (Electric heating type)	
	Idle speed (rpm) (elec. neutral or drive and propane if used)	Manual	650
		Automatic	750
Idle A/F ratio		Preset at manufacturer	
Fuel injection	Point of injection (no.)	-	
	Control (electronic, mech.)	-	
	System pressure (kPa (psi))	-	
	Intake manifold heat control (exhaust or water thermostatic or fixed)	Exhaust gas	
Air cleaner type	Standard	Dry type, 1 element with HAI	
	Optional	N.A.	
Fuel pump	Type (elec. or mech.)	Mechanical diaphragm type	
	Location (eng., tank)	Cylinder head, Rear	
	Pressure range (kPa (psi))	24.5 kPa	

Fuel Tank

Capacity (net) (L (gallons))		50L 13.2 GAL
Location (describe)		Under rear seat floor
Attachment		Band type
Material & Mass (kg (weight (lbs)))		Steel plate, 10.2 kg (22.5 lbs)
Filter	Location & material	Left wheel house, Steel
	Connection to tank	Rubber hose
Fuel line (material)		Steel pipe
Fuel hose (material)		Rubber
Return line (material)		Steel pipe
Vent line (material)		Steel pipe
Extended range tank	Qty. n.a.	N.A.
	Capacity (L (gallons))	-
	Location & material	-
	Attachment	-
Auxiliary tank	Qty. n.a.	N.A.
	Capacity (L (gallons))	-
	Location & material	-
	Attachment	-
	Selector switch or valve	-
Separate fill		-

Engine Description/Carb.
 Engine Code

4A-LC

Transmissions/Transaxle

Manual 3-speed (std., opt., n.a.) (mfr.)	-
Manual 4-speed (std., opt., n.a.) (mfr.)	-
Manual 5-speed (std., opt., n.a.) (mfr.)	Std.
Manual overdrive (std., opt., n.a.) (mfr.)	-
Automatic (std., opt., n.a.) (mfr.)	Std.
Automatic overdrive (std., opt., n.a.) (mfr.)	-

Manual Transmission/Transaxle

Number of forward speeds	5		
Transmission ratios	In first	3.545	
	In second	1.904	
	In third	1.233	
	In fourth	0.885	
	In fifth	0.725	
	In overdrive	-	
	In reverse	3.250	
Synchronous meshing (specify gears)	All forward gears (1st, 2nd, 3rd, 4th, and 5th)		
Shift lever location	Floor		
Lubricant	Capacity (L (pt.))	2.6L	
	Type recommended	Multi purpose API GL-4	
	SAE viscosity number	Summer	SAE 75W-90
		Winter	SAE 75W-90
Extreme cold		SAE 75W-90	

Clutch (Manual Transmission)

Make, type, engagement (describe) - (hydraulic, cable, rod)	Aisin Seiki Co., Ltd., Dry single plate-hydraulic	
Assist (yes, no, percent)	No	
Type pressure plate springs	Diaphragm spring	
Total spring load (N (lb.))	3920N	
No. of clutch driven discs	1	
Clutch bearing	Material	Semi-mold
	Manufacturer	Nissin spinning Co., Ltd.
	Part number	31256-01010
	Revs. min.	16
	Rivet size	φ4 mm
	Outside & inside dia.	200 mm x 140 mm
	Total oil area (cm ² (in. ²))	160 cm ²
	Thickness	3.5 mm
Engagement cushion method	Cushion spring	
Release bearing	Type & method of lubrication	Single row ball bearing, Sealed grease
Torsional damping	Method: springs, friction material	Rubber

Engine Description/Carb.
 Engine Code

4A-LC

Vehicle Emission Control

Exhaust Emission Control	Type (air injection, engine modifications, other)		EGR+AS+Oxygen Sensor+TWC+OC, EGR+AS+Oxygen Sensor+TWC*
	Air Injection	Pump or pulse	Reed valve
		Driven by	N.A.
		Air distribution (reed, manifold, etc.)	Catalytic converter, Exhaust manifold*
		Point of entry	Between TWC and OC, #3 branch*
	Exhaust Gas Recirculation	Type (controlled flow, open orifice, other)	Ex. back pressure
		Exhaust source	Exhaust manifold
		Point of exhaust injection (injector, carburetor, manifold, other)	Intake manifold
	Catalytic Converter	Type	3-way + Oxidation, 3-way*
		Number of	1
		Location(s)	Forward under floor area
		Volume [L (in ³)]	(1.3+0.7)L 1.3L*
	Substrate type	Monolith	
Crankcase Emission Control	Type (ventilates to atmosphere, induction system, other)		Induction system
	Energy source (manifold vacuum, carburetor, other)		Manifold vacuum
	Discharges to (intake manifold, other)		Intake manifold
	Air filter (breather cap, other)		Air cleaner
Evaporative Emission Control	Vapor vented to (crankcase, canister, other)	# fuel tanks	Canister
		Carburetor	Canister
	Vapor storage provision		Canister
Electronic System	Closed loop (yes/no)	Yes	
	Open loop (yes/no)	No	

*...California & Canada spec.

Engine - Exhaust System

Type (single, single with cross-over, dual, other)		Single
Muffler no. & type (reverse flow, straight thru, separate resonator) Material & Mass (kg (weight lbs))		1, Reverse flow
Resonator no. & type		-
Exhaust Pipe	Branch o.d. & wall thickness	-
	Main o.d. & wall thickness	42.7 mm, 2.0 mm
	Material & Mass (kg (weight lbs))	Stainless steel
Inter-mediate Pipe	o.d. & wall thickness	42.7 mm x 1.6 mm 42.7 mm x 1.2 mm
	Material & Mass (kg (weight lbs))	Aluminum-coated steel
Tail Pipe	o.d. & wall thickness	42.7 mm x 1.2 mm
	Material & Mass (kg (weight lbs))	Aluminum-coated steel

Engine Description/Car
 Engine Code

4A-LC

Automatic Transmission/Transaxle

Trade name		A131L
Type and special features (describe)		Hydraulic pressure controlled planetary gear
Sector	Location	Floor
	LF. No. designation	PRND2L
Gear ratios	1st	2.810
	2nd	1.549
	3rd	1.000
	4th	-
	Reverse	2.296
Max. overrun speed - drive range (km/h (mph))		1 → 2: 59 km/h 2 → 3: 108 km/h
Max. lockdown speed - drive range (km/h (mph))		2 → 1: 45 km/h 3 → 2: 105 km/h
Min. overrun speed (km/h (mph))		-
Torque converter	Number of elements	3
	Max. ratio at stall	2.100
	Type of cooling (air, liquid)	Water-cooled
	Nominal diameter	230 mm
Lubricant	Capacity (incl. L. (pt.))	5.5L
	Type Recommended	ATF Dexron II
<small>1: oiler (oil, oil, NA, normal, normal, oil, liquid)</small>		

Axle or Front Wheel Drive Unit

Type (front, rear)		Front wheel drive	
Description		Helical gear	
Limited slip differential (type)		N.A.	
Drive pinion offset		-	
Drive pinion (type)		Helical gear	
No. of differential pinions		2	
Pinion / differential adjustment (shim, other)		-	
Pinion / differential bearing adjustment (shim, other)		N.A., Collapsible Sleeve*	
Driving wheel bearing (type)		Double row, angular ball bearing	
Lubricant	Capacity (L. (pt.))	2.6L, 1.4L*	
	Type recommended	Multi purpose API GL-4, ATF Dexron II *	
	SAE viscosity number	Summer	SAE 75W-90, - *
		Winter	SAE 75W-90, - *
Extreme cold		SAE 75W-90, - *	

Axle or Transaxle Ratio and Teeth Combinations (See Power Trains for axle ratio usage.) *...Automatic transmission models

Axle ratio (or overall toe gear ratio)		3.722, 3.421* x 0.945 (counter gear ratio)
No. of teeth	Pinion	18, 19*
	Ring gear or gear	67, 65*
Ring gear o.d.		-
Transaxle	Transfer gear ratio	-
	Final drive ratio	-

*...Automatic transmission models

Car Line NOVA
 Model Year 1987 Issued _____ Revised (e) _____

Engine Description/Code
 Engine Code

4A-LC

Axle Shafts - Front Wheel Drive

Number used		2		
Type (straight, sand bar, tubular, etc.)	Left	Solid shaft		
	Right	Hollow shaft		
Outer diam. x length x wall thickness	Manual transmission	Left	23.8 mm x 338.0 mm	
		Right	38.0 mm x 627.6 mm x 5.0 mm	
	Automatic transmission	Left	23.8 mm x 338.0 mm	
		Right	38.0 mm x 627.6 mm x 5.0 mm	
	Optional transmission	Left		
		Right		
Spline yoke	Type	-		
	Number of teeth	-		
	Spine o.d.	-		
Journals and cones	Make and mtg. no.	Inner	GM S.S.G. make, 43403-01010	
		Outer	GM S.S.G. make, 43405-01010	
	Number used	4		
	Type, ass. plunge	Inner	Tripot (plunging)	
		Outer	Rzeppa (fixed)	
	Attach (u-bolts, clamp, etc.)		Snap ring	
Sealing	Type (oilm. anti-friction)	-		
	Lubrication (Wing, grease)	-		
Drive taken through (torque tube, arms or springs)		-		
Torque taken through (torque tube, arms or springs)		-		

* Consists of cone of universal joints, or to cone of attachment.

Car Line NOVA
 Model Year 1987 Issued _____ Revised (e) _____

Body Type And/Or
 Engine Displacement

All models

Suspension - General

Car leveling	Std. col. n.a.	N.A.
	Type (air, hyd., etc.)	-
	Manual/auto. controlled	-
Provision for brake oil control		-
Provision for acc. adjust control		-
Provisions for car jacking		-
Shock absorber (front & rear)	Type	Double-acting telescopic tube
	Make	Front: DELCO Rear: Kayaba
	Piston diameter	Front: 32 mm Rear: 25 mm
	Rod diameter	Front: 20 mm Rear: 18 mm

Suspension - Front

Type and description	MacPherson strut	
Drive and torque taken through		
Travel	Full bounce	80 mm
	Full rebound	85 mm
Spring	Type (coil, leaf, other) & material	Coil
	Insulators (type & material)	SUP7 NV
	Size (coil design height & i.d., bar length & dia.)	M/T: 375mm x 117.9mm, 383.5mm x 118.2mm (Air conditioned) A/T: 383.5mm x 118.2mm, 392mm x 117.7mm (Air conditioned)
	Spring rate (N/mm (lb. in.))	17.6 N/mm
	Rate at wheel (N/mm (lb. in.))	18.6 N/mm
Stabilizer	Type (link, wireless, transverse)	N.A.
	Material & bar diameter	-

Suspension - Rear

Type and description	MacPherson strut	
Drive and torque taken through	-	
Travel	Full bounce	85 mm
	Full rebound	100 mm
Spring	Type (coil, leaf, other) & material	Coil SUP7
	Size (length & width, coil design height & i.d., bar length & dia.)	Sedan: 325.5 mm x (88.8 - 118.8) mm Lift back: 331 mm x (88.7 - 118.7) mm
	Spring rate (N/mm (lb. in.))	18.6 N/mm
	Rate at wheel (N/mm (lb. in.))	20.6 N/mm
	Insulators (type & material)	Insulator (top and bottom)
	# leaf	No. of leaves Shocks (comp. or temp.)
Stabilizer	Type (link, wireless, transverse)	N.A.
	Material & bar diameter	-
Track bar (type)	N.A.	

Body Type AND/OR
 Engine Displacement

All models

Brakes - Service

Description				
Brake type (std., opt., n.a.)	Front (disc or drum)		Disc, Std.	
	Rear (disc or drum)		Drum, Std.	
Self-actuating (std., opt., n.a.)			Std.	
Spacer valving	Type (proportion, delay, metering, other)		Proportioning valve	
Power brake (std., opt., n.a.)			Std.	
Booster type (remote, resprg, vac., hyd., etc.)			Direct vacuum	
Vacuum source (trans. pump, etc.)			N.A.	
Vacuum reservoir (volume in. ³)			N.A.	
Vacuum pump-type (elec. gear driven, belt driven, if other so state)			N.A.	
Anti-lock device type (std., opt., n.a.) (F/R)			N.A.	
Effective area (cm ² /in. ²) ¹			Front: 164 cm ² Rear: 232 cm ²	
Gross lining area (cm ² /in. ²) ¹ (F/R)			Front: 164 cm ² Rear: 232 cm ²	
Swept area (cm ² /in. ²) ¹ (F/R)			Front: 1076 cm ² Rear: 377 cm ²	
Rotor	Outer working diameter	F/R	243 mm/N.A.	
	Inner working diameter	F/R	147 mm/N.A.	
	Thickness	F/R	13.5 mm/N.A.	
	Material & type (vented/solid)	F/R	Cast iron, Solid/N.A.	
Drum	Diameter & width	F/R	N.A./200.0 mm	
	Type and material	F/R	Cast iron	
Wheel cylinder bore			Front: 51.10 mm Rear: 17.46 mm	
Master cylinder	Bore stroke	F/R	Front: 22.22mm Rear: 22.22mm Front: 14.00mm Rear: 14.00mm	
Pedal arc ratio			4.15	
Line pressure at 445 N/100 lb. load (kPa (psi))			9273 kPa	
Lining clearance			F/R Self adjusting/Self adjusting	
Brake lining	Front wheel	Bonded or riveted (rivets seq.)		Bonded
		Rivet size		-
		Manufacturer		Bendix
		Lining code ^{****}		-
		Material		Resin molded
		---	Primary or out-board	102 mm x 42 mm x 10 mm
		Size	Secondary or in-board	102 mm x 42 mm x 10 mm
	Shoe thickness (no lining)		5.0 mm	
	Rear wheel	Bonded or riveted (rivets seq.)		Bonded
		Manufacturer		Nissin Spinning Co., Ltd.
		Lining Code ^{****}		-
		Material		Resin molded
		---	Primary or out-board	192 mm x 30 mm x 4 mm
		Size	Secondary or in-board	192 mm x 30 mm x 4 mm
Shoe thickness (no lining)		1.6 mm		

¹Excludes rivet holes, grooves, chamfers, etc.

²Includes rivet holes, grooves, chamfers, etc.

³Total swept area for four brakes. (Drum brake: Widest lining contact width for each brake x its contact circumference.) (Disc brake: Square of Outer Working Dia. minus Square of Inner Working Dia. multiplied by Pi/2 for each brake.)

⁴Size for drum brake includes length x width x thickness.

⁵Manufacturer I.D., catalog or formulation designation and coefficient of friction classification.

Car Line NOVA
 Model Year 1987 Issues _____ Revised (e) _____

Body Type And/Or
 Engine Displacement

4A-LC

Tires And Wheels (Standard)

Tires	Size (load range, ply)		P155/80 R13
	Type (bias, radial, etc.)		Radial
	Inflation pressure (cold) for recommended max. vehicle load	Front (kPa (psi))	193 kPa
		Rear (kPa (psi))	193 kPa
Rev./mile-at 70 mph (45 mph)		913	
Wheels	Type & material		Wide rim with deep bottom, Steel
	Rim (size & flange type)		5-Jx13
	Wheel offset		45 mm
	Attachment	Type (nut or stud)	Nut
		Circle diameter	100 mm
Number & size		4, 12P-1.5	
Spare	Tire and wheel (same, if other describe)		Tire: T115/70D14 Wheel: 4-Tx14
	Storage position & location (describe)		Trunk room

Tires And Wheels (Optional)

Size (load range, ply)		P175/70 R13
Type (bias, radial, etc.)		Radial
Wheel (type & material)		Wide rim with deep bottom, Steel & Aluminum
Rim (size, flange type and offset)		5-Jx13
Size (load range, ply)		
Type (bias, radial, etc.)		
Wheel (type & material)		
Rim (size, flange type and offset)		
Size (load range, ply)		
Type (bias, radial, etc.)		
Wheel (type & material)		
Rim (size, flange type and offset)		
Size (load range, ply)		
Type (bias, radial, etc.)		
Wheel (type & material)		
Rim (size, flange type and offset)		
Spare tire and wheel		
if configuration is different than standard tire or wheel, describe location, spare tire holder, wheel locker & storage position		Tire: T115/70D14 Wheel: 4-Tx14

Brakes - Parking

Type of control		-
Location of control		-
Operates on		-
If separate from service brakes	Type (mechanical or electrical)	N.A.
	Drum diameter	N.A.
	Lining size (length x width x thickness)	N.A.

Body Type 4-door
 Engine Displacement _____

All models

Steering

Manual (std., opt., n.a.)		Std.	
Power (std., opt., n.a.)		Opt.	
Adjustable steering wheel (std., steering, other)	Type and description	Tilt	
	Manufacturer	Toyota Motor Corporation	
	(Std., opt., n.a.)	Std. for CL models only	
Wheel diameter (WV) SAE J1100	Manual	380 mm	
	Power	380 mm	
Turning diameter in (ft.)	Outside front	Wall to wall (l. & r.)	10.2 mm
		Curb to curb (l. & r.)	9.4 mm (manual) 9.6 mm (power)
	Inside rear	Wall to wall (l. & r.)	5.0 mm (manual) 5.3 mm (power)
		Curb to curb (l. & r.)	5.3 mm (manual) 5.5 mm (power)
Steering Gear*			
Manual	Gear	Type	Rack and pinion
		Make	Toyota Motor Corporation
	Ratio	Gear	∞
		Overall	22.67
No. wheel turns (steer to steer)		4.07	
Power	Type (column, linkage, etc.)		Integral
	Make		Toyota Motor Corporation
	Gear	Type	Rack and pinion
		Ratio	Gear
	Overall		18.97
	Pump (drive)		V-ribbed belt
No. wheel turns (steer to steer)		3.35	
Linkage	Type		Accar man
	Location (front or rear of wheels, other)		Rear of wheels
	Tie rods (one or two)		2
Steering axis	Inclination of camber (deg.)		12°35'
	Bearings (type)	Upper	Ball bearing
		Lower	Ball joint
		Thrust	-
Steering spindle & joint type			
Wheel spindle	Diameter	Inner bearing	38 mm
		Outer bearing	74 mm
	Thread (size)		M19 x 1.5 mm
	Bearing (type)		Double row, angular ball bearing

*The horizontal distance in the front elevation between wheel centerline and kingpin (ball joint) axis at ground.

Body Type And/Or
 Engine Displacement

All models

Wheel Alignment

Front wheel at curb (incl. wt.)	Service steering	Caster (deg.)	0°53' ± 45'
		Camber (deg.)	-15' ± 45'
		Toe-in (outside track-mm (in.))	1 ± 4 mm
	Service road*	Caster	0°53' ± 30'
		Camber	-15' ± 30'
		Toe-in	1 ± 1 mm
	Periodic M.V. inspection	Caster	0°53' ± 45'
		Camber	-15' ± 45'
		Toe-in	1 ± 4 mm
Rear wheel at curb (incl. wt.)	Service steering	Camber (deg.)	-31' ± 45'
		Toe-in (outside track-mm (in.))	3.8 ± 4 mm
	Service road*	Camber	-31' ± 30'
		Toe-in	3.8 ± 2 mm
	Periodic M.V. inspection	Camber	-31' ± 45'
		Toe-in	3.8 ± 4 mm

* indicates pre-set, adjustable, trend set or other.

Electrical - Instruments and Equipment

Speedometer	Type	Analogue, Round
	Trig. camshaft (std., opt., n.a.)	Std.
ECR maintenance indicator		Non
Charge indicator	Type	Electrical
	Warning device	Lamp
Temperature indicator	Type	Electrical gauge
	Warning device	Non
Oil pressure indicator	Type	Electrical
	Warning device	Lamp
Fuel indicator	Type	Electrical gauge
	Warning device	Lamp
Windshield wiper	Type (standard)	Motor, 2-Speed
	Type (optional)	Motor, 3-Speed
	Blade length	Driver's side: 450 mm Passenger's side: 425 mm
	Swear area (cm ² (in. ²))	5880 cm ²
Windshield washer	Type (standard)	Motor
	Type (optional)	-
	Fuel level indicator	-
Rear window wiper, wiper/washer (std., opt., n.a.)		Opt.
Horn	Type	Electrical, Disc type
	Number used	1
Other		

Car Line NOVA
 Model Year 1987 Issued _____ Revised (e) _____

Engine Description/Car
 Engine Code

4A-LC

Electrical - Supply System

Battery	Make	Delco Remy
	Model, std. (opt.)	
	Voltage	12V
	Amperes at 0°F cold crank	310A
	Minimum-reserve capacity	90 minutes
	Amperes - 20 hr. rate	60
Location		Left front in engine compartment
Generator or alternator	Type and rating	Alternating, 60A
	Ratio (std. crank/rev.)	1:2.36
	Options (type & rating)	-
Regulator	Type	Integrated circuit type

Electrical - Starting System

Start. motor	Current drain at 0°F	-
	Engagement type	Shift type
Motor drive	Pinion engages from (front, rear)	Right

Electrical - Ignition System

Type	Electronic (std., opt., n.a.)	Std.	
	Other (specify)	N.A.	
Coil	Make	Nippondenso Co., Ltd.	
	Model	-	
	Current	Engine stopped - A	0
		Engine idling - A	0.9
Spark plug	Make	Nippondenso Co., Ltd., NGK Spark Plug Co., Ltd.	
	Model	W16EXR-U11, W14EXR-U11*, BPR5EY11, BPR4EY11*	
	Thread (mm)	M14 x 19.0	
	Tightening torque (N·m (lb. ft.))	N·m 17.7	
	Gap	1.1 mm	
Number per cylinder		1	
Distributor	Make	Nippondenso Co., Ltd.	
	Model	-	

* except California

Electrical - Suppression

Leads & type	Resistive cord, Resistive spark plug
--------------	--------------------------------------

Car Line NOVA
 Model Year 1987 Issued _____ Revised (e) _____

Body Type

All models

Body

Structure	Monocoque
Bumper system Front - rear	Front... Bar → Urethane (cover), PE (honeycomb) Reinforcement → Steel Rear ... Bar → Urethane (cover), PE (honeycomb) Reinforcement → Steel
Anti-corrosion treatment	Adoption of galvanized steel seat Application of adhesive & PVC sealer to the Hemming area Application of PVC undercoat CATHODIC ED Stone guard COAT Full dipping pretreatment

Body - Miscellaneous Information

Type of finish (lacquer, enamel, other)		Acryl
Head	Hinge location (front, rear)	Rear
	Type (counterbalance, prop)	Prop
	Release control (internal, external)	Internal
Trunk lid	Type (counterbalance, other)	Counterbalance
	Internal release control (elec., mech., n.a.)	N.A. (Base), Mechanical (CL)
Hatch-back lid	Type (counterbalance, other)	Counterbalance
	Internal release control (elec., mech., n.a.)	N.A. (Base), Mechanical (CL)
Vert window control (crank, friction, pivot, power)		Front - Rear -
Seat cushion type (e.g., 60/40, bucket, bench, wire, foam etc.)	Front	Panel frame + Foam pad
	Rear	Wire frame + Foam pad
	3rd seat	
Seat back type (e.g., 60/40, bucket, bench, wire, foam etc.)	Front	Tubler frame + Spring + Foam pad
	Rear	Board frame + Foam pad *1 Panel frame + Foam pad *2
	3rd seat	

*1 ... Sedan
 *2 ... Liftback

Car Line NOVA
 Model Year 1987 Issued _____ Revised (*) _____

Body Type

All models

Restraint System

Active restraint system	Standard/recommended	Standard
	Type and description	Front: 3-point ELR type 2 pcs Rear: 2-point ALR type 2 pcs & Non retractor type 1 pc
	Location	
Passive seat belts	Standard/recommended	N.A.
	Power/Manual	N.A.
	2 or 3 part	N.A.
	Knee barrier bar	N.A.

Frame

Type and description (separate frame, unitized frame, partially-unitized frame)	Monocoque
---	-----------

Glass	SAE Ref. No.		
Windshield glass exposed surface area (cm ² (in. ²))	S1	8750 cm ²	
Side glass exposed surface area (cm ² (in. ²)) - total 2-sides	S2	12395 cm ² (Sedan)	13060 cm ² (Lift back)
Rearlight glass exposed surface area (cm ² (in. ²))	S3	6560 cm ² (Sedan)	9340 cm ² (Lift back)
Total glass exposed surface area (cm ² (in. ²))	S4	27705 cm ² (Sedan)	31150 cm ² (Lift back)
Windshield glass (type)		Laminated glass	
Side glass (type)		Tempered glass	
Rearlight glass (type)		Tempered glass	

Body Type

All models

Convenience Equipment (standard, optional, n.a.)

Air conditioning		Opt.
Clock (digit. analog)		N.A.
Compass / thermometer		N.A.
Console (floor, overhead)		Std. (only floor)
Crewster, elec. headlight		Opt.
Electronic	Diagnostic warning (integrated, individual)	N.A.
	Instrument cluster (lit instruments)	N.A.
	Keyless entry	N.A.
	Trimender (avg. spd., fuel)	N.A.
	Voice start (lit name)	N.A.
	Other	-
Fuel door lock (remote, key, electric)		Key (Base models), remote (CL models)
Lamps	Auto head on / off delay, dimming	N.A.
	Cornering	N.A.
	Courtesy (map, reading)	N.A.
	Door lock, ignition	N.A.
	Engine compartment	N.A.
	Fog	N.A.
	Glove compartment	N.A.
	Trunk	N.A. (base models) Std. (CL models)
Mirrors	Day/night (auto, man.)	Std.: man.
	L.H. (remote, power, heated)	Std.: remote
	R. H. (convex, remote, power, heated)	Opt.: convex
	Visor vanity (RH / LH, illuminated)	N.A. (base models) Std. (CL models RH)
Parking brake-auto release (warning light)		Std.
Power equipment	Door locks, deck lid - specify	Opt.: Door locks
	Seat (2-4 way) heated (driver, pass, other) lumbar, hip, thigh support (power, manual) resting (driver, pass) memory (1-2 preset, recline)	N.A.
	Side windows	Opt.
	Vent windows	N.A.
	Rear window	N.A.
Radio systems	Antenna (telescopic, whip, windshield, power)	Opt.
	AM, FM, stereo, tape, CB	Opt.
	Speaker (number, location) Premium sound	-
Roof open surface (tie-up, strap, "T")		N.A.
Speed control device		Opt.
Speed warning device (light, buzzer, etc.)		N.A.
Tachometer (rpm)		N.A.
Third prescaler-eye		Steering lock

See Key Sheets for definitions

All dimensions to ground are for comparative purposes only. Dimensions are to be shown for all base body models of each car line. SAE Ref. no. refers to the definition published in SAE Recommended Practice J1100 "Motor Vehicle Dimensions," unless otherwise specified.

SAE Ref. No.	All models
--------------	------------

Body Type
Width

Tread (front)	W101	1425 mm
Tread (rear)	W102	1405 mm
Vehicle width	W103	1635 mm
Body width at Sq MP (front)	W117	1625 mm
Vehicle width (front doors open)	W120	3275 mm
Vehicle width (rear doors open)	W121	3150 mm
Front fender overall width	W106	1635 mm
Rear fender overall width	W107	1635 mm
Turn-in-home (deg.)	W122	20.8°

Length

Wheelbase	L101	2430 mm
Vehicle length	L103	4225 mm
Overhang (front)	L104	845 mm
Overhang (rear)	L105	950 mm
Upper structure length	L123	2475 mm (Sedan) 2795 mm (Lift back)
Rear wheel C L "X" coordinate	L127	2430 mm
Cowl point "X" coordinate	L125	395 mm
Front end length at centerline	L126	1140 mm
Rear end length at centerline	L129	410 mm (Sedan) 80 mm (Lift back)

Height*

Passenger distribution (front/rear)	P0123	Front: 2 Rear: 1
Trunk cargo load		0 kg
Vehicle height	H101	1340 mm
Cowl point to ground	H114	895 mm
Deck point to ground	H138	960 mm
Rocker panel-front to ground	H112	195 mm
Bottom of door closed-front to grd	H133	275 mm
Rocker panel-rear to ground	H111	190 mm
Bottom of door closed-rear to grd	H135	275 mm
Windshield slope angle	H122	56.8°
Backlight slope angle	H121	57°

Ground Clearance*

Front bumper to ground	H102	380 mm
Rear bumper to ground	H104	350 mm
Bumper to ground (front at curb mass (wt.))	H103	395 mm
Bumper to ground (rear at curb mass (wt.))	H105	400 mm
Angle of approach (degrees)	H106	19.0°
Angle of departure (degrees)	H107	17.0°
Ramp break-over angle (degrees)	H147	14.5°
Axle differences to ground (front - rear)	H153	-
Min. running ground clearance	H156	135 mm
Location of min. run. grd. clear		Federal: Air suction pipe California: Converter

* All vehicle height and ground clearances are made at the Manufacturer's Design Load Weight, unless otherwise specified. Manufacturer's Design Load Weight is defined with indicated passenger distribution and trunk cargo load.

Car Line NOVA
 Model Year 1987 Issued _____ Revised (e) _____

See Key Sheets for definitions

Body Type

SAE Ref. No.	All models
--------------	------------

Front Compartment

Sg RP front "X" coordinate	L31	1350 mm
Effective head room	H81	963 mm
Max. eff. leg room (accelerator)	L34	1078 mm
Sg RP to heel point	H30	278 mm
Sg RP to heel point	L53	868 mm
Back angle	L40	21°
Hip angle	L42	96.5°
Knee angle	L44	129°
Foot angle	L46	80.5°
Design H-point front travel	L17	LH 209 mm, RH 194 mm
Normal driving & riding seat track trvl.	L23	LH 209 mm, RH 194 mm
Shoulder room	W3	1366 mm
Hip room	W5	1273 mm
Upper body opening to ground	H50	1235 mm
Steering wheel maximum diameter	W9	
Steering wheel angle	H18	25°
Accel. heel pt. to steer. whl. ctr.	L11	433.5 mm
Accel. heel pt. to steer. whl. ctr.	H17	658 mm
Steering wheel to C. L. of thigh	H13	90.5 mm (w/Tilt steering)
Steering wheel torso clearance	L7	405 mm
Headroom to roof panel (front)	H37	14 mm
Undeformed floor covering thickness	H67	11 mm

Rear Compartment

Sg RP Post coupe distance	L50	695 mm
Effective head room	H83	928 mm (Sedan) 903 mm (Lift back)
Min. effective leg room	L51	812 mm
Sg RP (second to heel)	H31	321 mm
Knee clearance	L48	-34 mm
Compartment room	L3	604 mm
Shoulder room	W4	1366 mm (Sedan) 1361 mm (Lift back)
Hip room	W8	1312 mm (Sedan) 1209 mm (Lift back)
Upper body opening to ground	H81	1245 mm
Back angle	L41	27°
Hip angle	L43	87°
Knee angle	L45	75.5°
Foot angle	L47	105.5°
Headroom to roof panel (second)	H38	14 mm
Decreased floor covering thickness	H73	9.5 mm

Luggage Compartment

Usable luggage capacity (L. (cu. ft.))	V1	0.39 m ³ (13.8 cu. ft.)
Liftover height	H98	585 mm (Sedan) 590 mm (Lift back)

Interior Volumes (EPA Classification)

Vehicle class (subcompact, compact, etc.)		-
Interior volume index (cu. ft.)		-
Trunk/cargo index (cu. ft.)		-

See Key Sheets for definitions

Body Type

SAE Ref. No.

5-Door Lift back

Station Wagon - Third Seat

Sg RP coupe distance	L85	-
Shoulder room	W85	-
Hip room	W86	-
Effective hip room	L86	-
Effective head room	H86	-
Sg RP to heel point	H87	-
Knee clearance	L87	-
Seat facing direction	S01	-
Back angle	L88	-
Hip angle	L89	-
Knee angle	L90	-
Foot angle	L91	-

Station Wagon - Cargo Space

Cargo length (open front)	L200	-
Cargo length (open second)	L201	-
Cargo length (closed front)	L202	-
Cargo length (closed second)	L203	-
Cargo length at belt (front)	L204	-
Cargo length at belt (second)	L205	-
Cargo width (wheelhouse)	W201	-
Rear opening width at floor	W203	-
Opening width at belt	W204	-
Max. rear opening width above belt	W205	-
Cargo height	H201	-
Rear opening height	H202	-
Tailgate to ground height	H250	-
Front seat back to load floor height	H197	-
Cargo volume index (m ³ /ft. ³)	V2	-
Hidden cargo volume (m ³ /ft. ³)	V4	-
Cargo volume index-rear of 2-seat	V10	-

Hatchback - Cargo Space

Cargo length at front seatback height	L208	1465 mm
Cargo length at floor (front)	L209	1637 mm
Cargo length at second seatback height	L210	676 mm
Cargo length at floor (second)	L211	940 mm
Front seatback to load floor height	H197	476 mm
Second seatback to load floor height	H198	516 mm
Cargo volume index (m ³ /ft. ³)	V3	1.005 m ³ (35.5 cu.ft.)
Hidden cargo volume (m ³ /ft. ³)	V4	-
Cargo volume index-rear of 2-seat	V11	0.567 m ³ (20.2 cu.ft.)

Aerodynamics*

Wheel to ground, front	
Wheel to ground, rear	
Frontal area (m ² /ft. ²)	
Drag coefficient (Cd)	

* EPA Loaded Vehicle Weight, Loading Conditions

Body Type

All models

Vehicle Fiducial Marks

Fiducial Mark Number*	Define Coordinate Location															
Front	The center of outer installation hole for seat track of front floor cross member (both sides)															
Rear	The center of front installation hole for rear seat belt retractor of rear floor (both sides)															
Front	<table border="1" style="width: 100%; border-collapse: collapse;"> <tr> <td style="width: 10%;">W21</td> <td style="width: 10%;"></td> <td style="width: 80%;">W5 + 79 mm</td> </tr> <tr> <td>L54</td> <td></td> <td>L20 mm</td> </tr> <tr> <td>H81</td> <td></td> <td>H10 + 86 mm</td> </tr> <tr> <td>H181</td> <td></td> <td>275 mm</td> </tr> <tr> <td>H183</td> <td></td> <td>305 mm</td> </tr> </table>	W21		W5 + 79 mm	L54		L20 mm	H81		H10 + 86 mm	H181		275 mm	H183		305 mm
W21		W5 + 79 mm														
L54		L20 mm														
H81		H10 + 86 mm														
H181		275 mm														
H183		305 mm														
Rear	<table border="1" style="width: 100%; border-collapse: collapse;"> <tr> <td style="width: 10%;">W22</td> <td style="width: 10%;"></td> <td style="width: 80%;">W5 + 3 mm</td> </tr> <tr> <td>L56</td> <td></td> <td>L30 + 35 mm</td> </tr> <tr> <td>H82</td> <td></td> <td>H11 + 23 mm</td> </tr> <tr> <td>H182</td> <td></td> <td>315 mm</td> </tr> <tr> <td>H184</td> <td></td> <td>360 mm</td> </tr> </table>	W22		W5 + 3 mm	L56		L30 + 35 mm	H82		H11 + 23 mm	H182		315 mm	H184		360 mm
W22		W5 + 3 mm														
L56		L30 + 35 mm														
H82		H11 + 23 mm														
H182		315 mm														
H184		360 mm														

* Reference - SAE Recommended Practice, J182, Motor Vehicle Fiducial Marks.
 All linear dimensions are in millimeters (inches).

Body Type

SAE Ref. 4-Door Sedan No.	5-Door Lift back
---------------------------------	------------------

Lamps and Headlamp Shape*

Height above ground to center of bulb or marker	Headlamp (SAE - H127)	Highest**	630 mm	
		Lowest	-	
	Tailamp (SAE - H128)	Highest**	855 mm	675 mm
		Lowest	835 mm	-
	Sidemarker	Front	625 mm	
		Rear	655 mm	
Distance from C.L. of car to center of bulb	Headlamp	Inside	415 mm	
		Outside**	592 mm	
	Tailamp	Inside	535 mm	580 mm
		Outside**	668 mm	687 mm
	Directional	Front	527 mm	
		Rear	668 mm	687 mm
Halogen headlamp (std., opt., n.a.)	Lo beam	60W		
	Hl beam	40 + 50W		
	Replaceable bulb	N.A.		
	Shape	Rectangular, 4 lamps		
Headlamp other than above	Lo beam	60W		
	Hl beam	40 + 50W		
	Replaceable	N.A.		
	Shape	Rectangular, 4 lamps		
	Type	Lo beam: 4652, Hl beam: 4651		

* Measures at curb mass (weight).
 ** If single lamps are used enter here

Model	Vehicle Mass (weight)							
	CURB MASS, kg. (weight D.1)			% PASS MASS DISTRIBUTION				SHIPPING MASS kg. (weight D.1)**
	Front	Rear	Total	Pass in Front		Pass in Rear		
Front				Rear	Front	Rear		
AE82L-FEMDCA	608	393	1001	45	55	16	84	974
AE82L-FEHDCA	624	395	1019	45	55	16	84	992
AE82L-FEMNCA	612	398	1010	45	55	16	84	983
AE82L-FEHNCA	628	400	1028	45	55	16	84	1001
AE82L-FLMDCA	602	420	1022	45	55	16	84	995
AE82L-FLHDCA	618	420	1038	45	55	16	84	1011
AE82L-FLMNCA	606	425	1031	45	55	16	84	1004
AE82L-FLHNCA	617	423	1040	45	55	16	84	1013
AE82L-FEMDCK	608	393	1001	45	55	16	84	974
AE82L-FEHDCK	624	395	1019	45	55	16	84	992
AE82L-FEMNCK	612	398	1010	45	55	16	84	983
AE82L-FEHNCK	628	400	1028	45	55	16	84	1001
AE82L-FLMDCK	602	420	1022	45	55	16	84	995
AE82L-FLHDCK	618	420	1038	45	55	16	84	1011
AE82L-FLMNCK	606	425	1031	45	55	16	84	1004
AE82L-FLHNCK	617	423	1040	45	55	16	84	1013

* Reference - SAE J1100 Motor vehicle dimensions, curb weight definition.
 - Shipping mass (weight) definition -

Exterior Car And Body Dimensions - Key Sheet

Exterior Width

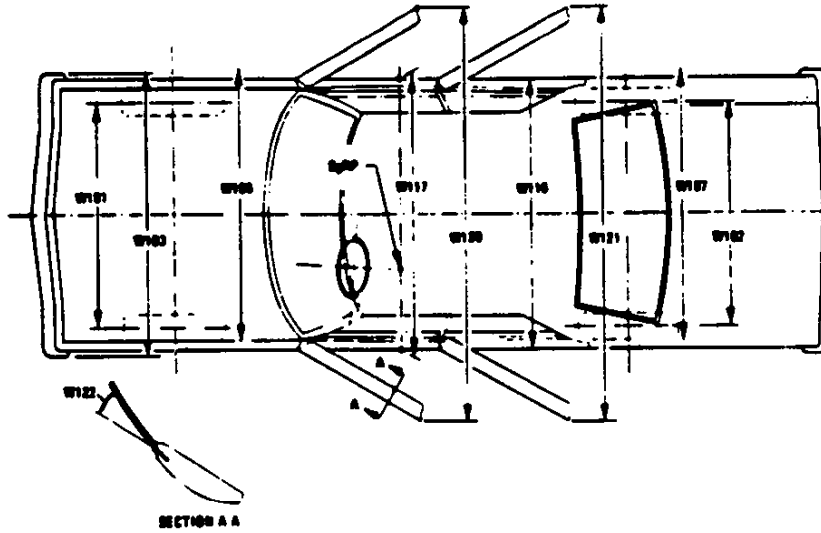

Exterior Length & Height

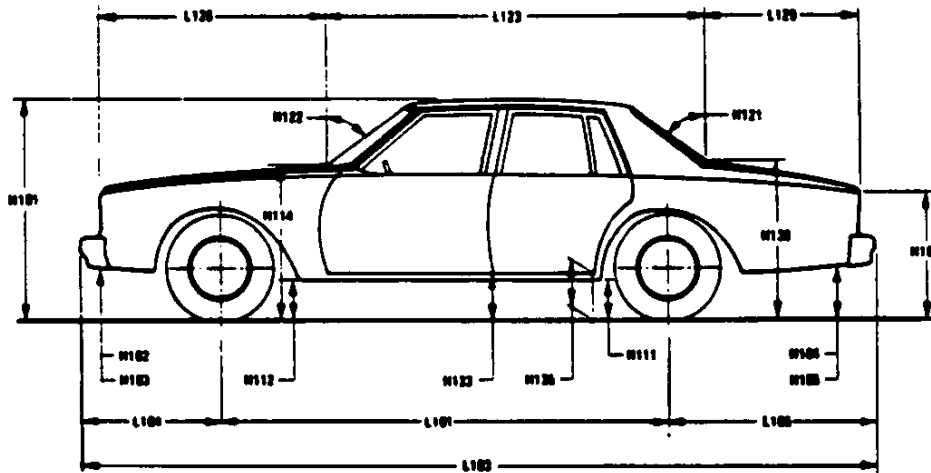

Exterior Ground Clearance

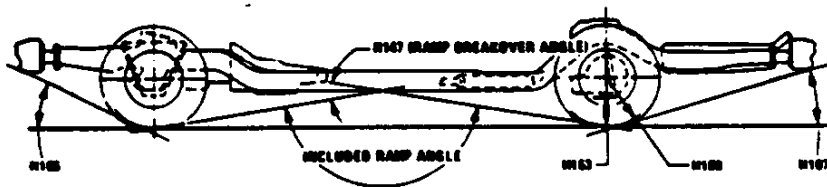

Interior Car And Body Dimensions – Key Sheet

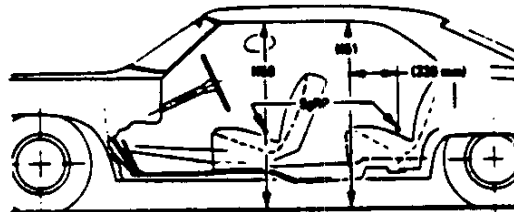
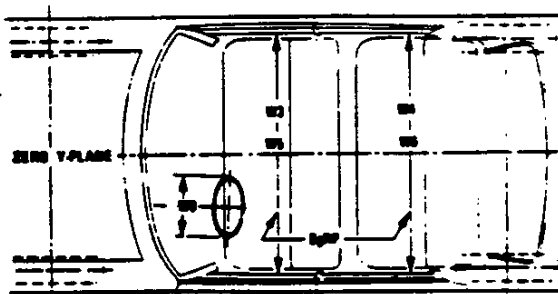
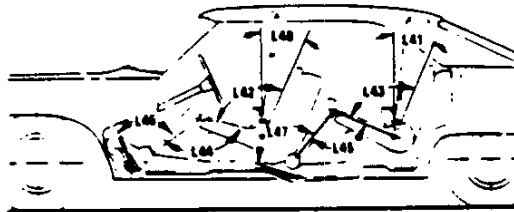
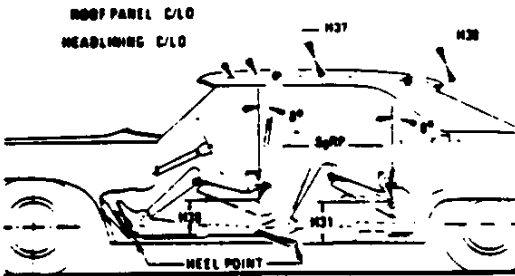
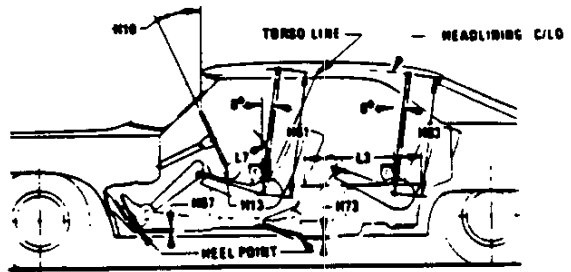
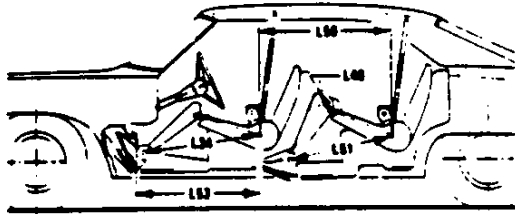

Interior Car And Body Dimensions - Key Sheet

Third Seat

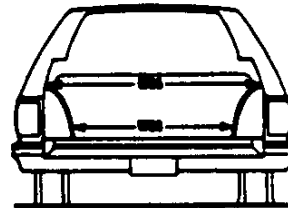
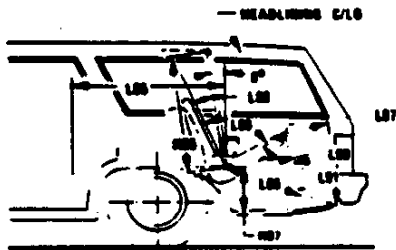

Cargo Space

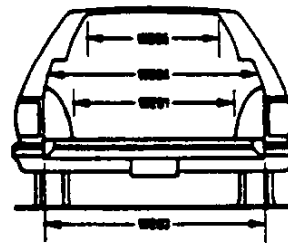
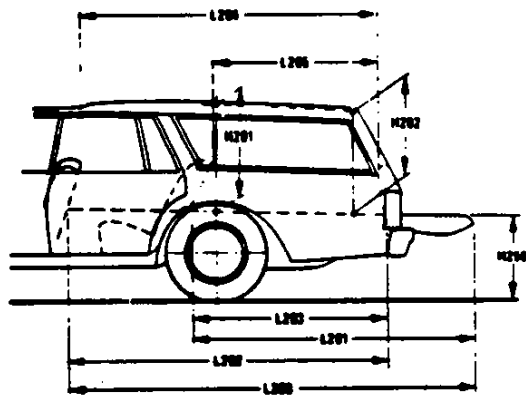

Station Wagon

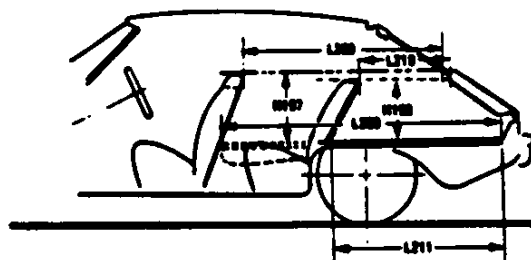

Hatchback

**Exterior Car And Body Dimensions – Key Sheet
Dimensions Definitions**

Seating Reference Point

SEATING REFERENCE POINT means the manufacturer's design reference point which –
(a) Establishes the rearmost normal design driving or riding position of each designated seating position in a vehicle
(b) Has coordinates established relative to the design vehicle structure.
(c) Simulates the position of the pivot center of the human torso and thigh; and
(d) Is the reference point employed to position the two dimensional templates described in SAE Recommended Practice J826. Devices for Use in Defining and Measuring Vehicle Seating Accommodations.

Width Dimensions

- W101 TREAD-FRONT The dimension measured between the tire centerlines at the ground
- W102 TREAD-REAR The dimension measured between the tire centerlines at the ground. In case of dual wheels, the dimension will be measured to the centerline of tire and wheel assemblies
- W103 VEHICLE WIDTH The maximum dimension measured between the widest point on the vehicle, excluding exterior mirrors, flexible mud flaps, marker lamps, but including bumpers, moldings, sheet metal protrusions or dual wheels, if standard equipment
- W106 FRONT FENDER WIDTH The dimension measured between the widest points at the front wheel centerline, excluding moldings
- W107 REAR FENDER WIDTH The dimension measured between the widest points at the rear wheel centerline, excluding moldings
- W117 BODY WIDTH AT SgRP-FRONT The dimension measured laterally between the widest points on the body at the SgRP-front, excluding door handles, applied moldings or appliques
- W120 VEHICLE WIDTH-FRONT DOORS OPEN The dimension measured between the widest point on the front doors in maximum hold-open position
- W121 VEHICLE WIDTH-REAR DOORS OPEN The dimension measured between the widest point on the rear doors in maximum hold-open position. For vehicles with a rear door on only one side, this dimension is to the zero "Y" plane
- W122 TUMBLE-HOME STRAIGHT SIDE GLASS The angle measured from a vertical to the outside surface of the front door glass at the SgRP "X" plane
CURVED SIDE GLASS The angle measured from a vertical to a chord extending from the upper DLO to the lower DLO at the outside surface of the front door glass at the front SgRP "X" plane

Length Dimensions

- L101 WHEELBASE (WB) The dimension measured longitudinally between front and rear wheel centerlines. In case of dual rear axles, the dimension shall be to the midpoint of the centerlines of the rear wheels.
- L103 VEHICLE LENGTH The maximum dimension measured longitudinally between the foremost point and the rearmost point on the vehicle, including bumper, bumper guards, tow hooks and/or rub strips, if standard equipment.
- L104 OVERHANG-FRONT The dimension measured longitudinally from the centerline of the front wheels to the foremost point on the vehicle including bumper, bumper guards, tow hooks and/or rub strips, if standard equipment.
- L105 OVERHANG-REAR The dimension measured longitudinally from the centerline of the rear wheels; or in the case

of dual rear axles, the dimension shall be the midpoint of the centerlines of the rear wheels, to the rearmost point on the vehicle including rear bumpers, bumper guards, tow hooks and rub strips, if standard equipment.

- L123 UPPER STRUCTURE LENGTH The dimension measured longitudinally from the cowl point to the deck point
- L125 COWL POINT "X" COORDINATE
- L126 FRONT END LENGTH The dimension measured longitudinally from the cowl point to the foremost point on the vehicle at the zero "Y" plane, excluding ornamentation or bumpers. In cases where bumpers and/or grills are integrated with the profile, measurement is made at the foremost point of front end contour.
- L127 REAR WHEEL CENTERLINE "X" COORDINATE or in the case of dual rear axles, the coordinate shall be the midpoint of the distance between the rear axle centerlines.
- L129 REAR END LENGTH The dimension measured longitudinally from the deck point to the rearmost visible point of the body sheet metal at the zero "Y" plane, excluding ornamentation or bumpers

Height Dimensions

- H101 VEHICLE HEIGHT The dimension measured vertically from the highest point on the vehicle body to ground
- H111 ROCKER PANEL-REAR TO GROUND The dimension measured vertically from the bottom of the rocker or side quarter panel at the front of the rear wheel opening, excluding flanges, to ground
- H112 ROCKER PANEL-FRONT TO GROUND The dimension measured vertically from the foremost point on the bottom of the rocker panels, excluding flanges, to ground
- H114 COWL POINT TO GROUND Measured at zero "Y" plane
- H121 BACKLIGHT SLOPE ANGLE The angle between the vertical reference line and the surface of backlight at vehicle zero "Y" plane. For curve backlight, the angle is to chord of backlight arc from lower DLO to upper DLO
- H122 WINDSHIELD SLOPE ANGLE The angle between the vertical reference line and a chord of the windshield arc running from the lower DLO to the upper DLO at the vehicle zero "Y" plane. In the case of wrap over glass, the angle to be measured will be formed by a chord 457 mm (18 0 in) long drawn from the lower DLO to the intersecting point on the windshield
- H127 HEADLAMP TO GROUND-CURB MASS (WT.) The dimension measured vertically from the centerline of the lowest headlamp lens to ground
- H128 TAILLAMP TO GROUND-CURB MASS (WT.) The dimension measured vertically from the centerline of the upper bulb to ground
- H133 BOTTOM OF DOOR CLOSED-FRONT TO GROUND The dimension measured vertically from the bottom outside corner of the door on the lock pillar side, in maximum closed position, to ground.
- H135 BOTTOM OF DOOR CLOSED-REAR TO GROUND The dimension measured vertically from the bottom outside corner of the door on the lock pillar side, in maximum closed position, to ground.
- H138 DECK POINT TO GROUND. Measured at zero "Y" plane.
- H109 STATIC LOAD-TIRE RADIUS-REAR. Specified by the manufacturer in accordance with composite TIRE SECTION STANDARD.

Ground Clearance Dimensions

- H102 FRONT BUMPER TO GROUND The minimum dimension measured vertically from the lowest point on the front bumper to ground, including bumper guards, if standard equipment.
- H103 FRONT BUMPER TO GROUND-CURB MASS (WT.) Measured in the same manner as H102.

**Interior Car And Body Dimensions – Key Sheet
Dimensions Definitions**

H104	REAR BUMPER TO GROUND. The minimum dimension measured vertically from the lowest point on the rear bumper to ground, including bumper guards, if standard equipment.	L34	MAXIMUM EFFECTIVE LEG ROOM-ACCELERATOR. The dimension measured along a line from the ankle pivot center to the SgRP-front plus 254 mm (10.0 in.) measured with right foot on the undepressed accelerator pedal. For vehicles with SgRP to heel (H30) greater than 18 in., the accelerator pedal may be depressed as specified by the manufacturer. If the accelerator is depressed, the manufacturer shall place foot flat on pedal and note the depression of the pedal.
H105	REAR BUMPER TO GROUND – CURB MASS (WT.). Measured in the same manner as H104.	L40	BACK ANGLE-FRONT. The angle measured between a vertical line through the SgRP-front and the torso line. If the seatback is adjustable, use the normal driving and riding position specified by the manufacturer.
H106	ANGLE OF APPROACH. The angle measured between a line tangent to the front tire static loaded radius arc and the initial point of structural interference forward of the front tire to ground. The limiting structural component shall be designated.	L42	HIP ANGLE-FRONT. The angle measured between torso line and thigh centerline.
H107	ANGLE OF DEPARTURE. The angle measured between a line tangent to the rear tire static loaded radius arc and the initial point of structural interference rearward of the rear tire to ground. The limiting component shall be designated.	L44	KNEE ANGLE-FRONT. The angle measured between thigh centerline and lower leg centerline measured on the right leg.
H147	RAMP BREAKOVER ANGLE. The angle measured between two lines tangent to the front and rear tire static loaded radius and intersecting at a point on the underside of the vehicle which defines the largest ramp over which the vehicle can roll.	L46	FOOT ANGLE-FRONT. The angle measured between the lower leg centerline and a line tangent to the ball and heel of the bare foot flesh line measured on the right leg. Ref SAE J826.
H153	REAR AXLE DIFFERENTIAL TO GROUND. The minimum dimension measured from the rear axle differential to ground.	L53	SgRP-FRONT TO HEEL. The dimension measured horizontally from the SgRP-front to the accelerator heel point.
H156	MINIMUM RUNNING GROUND CLEARANCE. The minimum dimension measured from the sprung vehicle to ground. Specify location.	W3	SHOULDER ROOM-FRONT. The minimum dimension measured laterally between the trimmed surfaces on the "X" plane through the SgRP-front at height between the belt line and 254 mm (10.0 in.) above the SgRP-front, excluding the door assist strap and attaching parts.
Glass Areas		W5	HIP ROOM-FRONT. The minimum dimension measured laterally between the trimmed surfaces on the "X" plane through the SgRP-front within 25 mm (1.0 in.) below and 76 mm (3.0 in.) above the SgRP-front and 76 mm (3.0 in.) fore and aft of the SgRP-front.
S1	Windshield area.	W9	STEERING WHEEL MAXIMUM OUTSIDE DIAMETER. Define if other than round.
S2	Side windows area. Includes the front door, rear door, vents, and rear quarter windows on both sides of the vehicle.	H13	STEERING WHEEL TO CENTERLINE OF THIGH. The minimum dimension measured from the bottom of steering wheel, with front wheels in the straight position, to the thigh centerline.
S3	Backlight areas.	H17	ACCELERATOR HEEL POINT TO THE STEERING WHEEL CENTER. The dimension measured vertically from the AHP-front to the intersection of the steering column centerline to a plane tangent to the upper surface of the steering wheel rim.
S4	Total area. Total of all areas (S1 + S2 + S3)	H18	STEERING WHEEL ANGLE. The angle measured from a vertical to the surface plane of the steering wheel.
Fiducial Mark Dimensions		H30	SgRP-FRONT TO HEEL. The dimension measured vertically from the SgRP-front to the accelerator heel point.
	Fiducial Mark – Number 1	H37	HEADLINING TO ROOF PANEL-FRONT. The dimension measured from the intersection of the headlining and the extended effective head room line normal to the sheet metal.
L54	"X" coordinate.	H50	UPPER BODY OPENING TO GROUND-FRONT. The dimension measured vertically from the trimmed body opening to the ground on the SgRP-front "X" plane.
W21	"Y" coordinate.	H61	EFFECTIVE HEAD ROOM-FRONT. The dimension measured along a line 8 deg. rear of vertical from the SgRP-front to the headlining plus 102 mm (4.0 in.).
H61	"Z" coordinate.	H67	FLOOR COVERING THICKNESS-UNDEPRESSED-FRONT. The dimension measured vertically from the surface of the undepressed floor covering to the underbody sheet metal at the accelerator heel point.
H161	Height "Z" coordinate to ground at curb weight.	PD1	PASSENGER DISTRIBUTION-FRONT.
H163	Height "Z" coordinate to ground.	Rear Compartment Dimensions	
	Fiducial Mark – Number 2	L3	COMPARTMENT ROOM-SECOND. The dimension measured horizontally from the back of front seat to the front of the second seatback at a height tangent to the top of the second seat cushion.
L55	"X" coordinate.		
W22	"Y" coordinate.		
W82	"Z" coordinate.		
H162	Height "Z" coordinate to ground at curb weight.		
H164	Height "Z" coordinate to ground.		
Front Compartment Dimensions			
L7	STEERING WHEEL TORSO CLEARANCE. The minimum dimension measured in the side view from the rearmost edge of the steering wheel, with front wheels in the straight ahead position, to the torso line.		
L11	ACCELERATOR HEEL POINT TO STEERING WHEEL CENTER. The dimension measured horizontally from the AHP to the intersection of the steering column centerline and a plane tangent to the upper surface of the steering wheel rim.		
L17	DESIGN H-POINT-FRONT TRAVEL. The dimension measured horizontally between the design H-point-front in the foremost and rearmost seat track positions. (See SAE J1100)		
L23	NORMAL DRIVING AND RIDING SEAT TRACK LEVEL. The dimension measured horizontally between a point on the design H-point travel line from the SgRP to the displaced point on the design H-point travel line with the seat moved to the foremost seat position, but not to include seat track travel used for purposes other than normal driving and riding positions. (See SAE J1100)		
L31	SgRP-FRONT. "X" COORDINATED.		

Interior Car And Body Dimensions - Key Sheet
Dimensions Definitions

- L-41 **BACK ANGLE-SECOND** The angle measured between a vertical line through the SgRP-second and the torso line
- L43 **HIP ANGLE-SECOND** The angle measured between torso line and thigh centerline
- L45 **KNEE ANGLE-SECOND** The angle measured between thigh centerline and lower leg centerline
- L47 **FOOT ANGLE-SECOND** The angle measured between the lower leg centerline and a line tangent to the ball and heel of the three-dimensional devices bare foot flesh line (Reference J826)
- L48 **KNEE CLEARANCE-SECOND** The minimum dimension measured from the knee pivot center to the back of the front seatback minus 51 mm (2.0 in.)
- L50 **SgRP COUPLE DISTANCE-SECOND** The dimension measured horizontally from the driver SgRP-front to the SgRP-second
- L51 **MINIMUM EFFECTIVE LEG ROOM-SECOND** The dimension measured along a line from the ankle pivot center to the SgRP-second plus 254mm (10.0 in.)
- W4 **SHOULDER ROOM-SECOND** The minimum dimension measured laterally between door or quarter trimmed surfaces on the "X" plane through the SgRP-second at height between 254-406 mm (10.0-16.0 in.) above the SgRP-second, excluding the door assist straps and attaching parts
- W6 **HIP ROOM-SECOND** Measured in the same manner as W5
- H31 **SgRP-SECOND TO HEEL** The dimension measured vertically from the SgRP-second to the two dimensional device heel point on the depressed floor covering
- H38 **HEADLINING TO ROOF PANEL-SECOND** The dimension measured from the intersection of the headlining and the extended effective head room line normally to the roof sheet metal
- H51 **UPPER BODY OPENING TO GROUND-SECOND** The dimension measured vertically from the trimmed body opening to the ground on the "X" plane 330 mm (13.0 in.) forward of the SgRP-second
- H63 **EFFECTIVE HEAD ROOM-SECOND** The dimension measured along a line 8 deg rear of vertical from the SgRP to the headlining, plus 102 mm (4.0 in.)
- H73 **FLOOR COVERING-DEPRESSED-SECOND** The dimension measured vertically from the heel point to the underbody sheet metal
- PD2 **PASSENGER DISTRIBUTION-SECOND**

Luggage Compartment Dimensions

- V1 **USABLE LUGGAGE CAPACITY**-Total of volumes of individual pieces of standard luggage set plus H-boxes stowed in the luggage compartment in accordance with the procedure described in paragraph 8.2 of SAE-J1100a.
- H195 **LIFTOVER HEIGHT** The dimension measured vertically from the luggage compartment lower opening at the zero "Y" plane to ground.

Interior Volumes (EPA Classification)

The Interior Volume Index is listed for each body style except two seaters. The interior volume index estimates the space in a car. It is based on four measurements - head room, shoulder room, hip room, and leg room - for the front and rear seats, plus trunk capacity. The interior volume index is an estimate of the size of the passenger compartment.

The Trunk Cargo Index is an estimate of the size of the trunk cargo space. In station wagons and hatchbacks it is an estimate of the space behind the second seat.

Station Wagon - Third Seat Dimensions

- L85 **SgRP COUPLE DISTANCE-THIRD** The dimension measured horizontally from the SgRP-second to the SgRP-third
- L86 **EFFECTIVE LEG ROOM-THIRD** The dimension measured along a line from the ankle pivot center to the SgRP-third plus 254 mm (10.0 in.)
- L87 **KNEE CLEARANCE-THIRD** The minimum dimension from the knee pivot center to the back of second seatback minus a constant of 51mm (2.0 in.) With rear-facing third seat, dimension is measured to closure.
- L88 **BACK ANGLE-THIRD** Measured in the same manner as L41
- L89 **HIP ANGLE-THIRD** Measured in the same manner as L43
- L90 **KNEE ANGLE-THIRD** Measured in the same manner as L45.
- L91 **FOOT ANGLE-THIRD** Measured in the same manner as L47
- W85 **SHOULDER ROOM-THIRD** Measured in the same manner as W4
- W86 **HIP ROOM-THIRD** Measured in the same manner as W5
- H86 **EFFECTIVE HEAD ROOM-THIRD** The dimension, measured along a line 8 deg from the SgRP-third to the headlining rear of vertical plus a constant of 102 mm (4.0 in.)
- H87 **SgRP-THIRD TO HEEL POINT**
- PD3 **PASSENGER DIRECTION-THIRD**
- SD1 **SEAT FACING DIRECTION-THIRD**

Station Wagon - Cargo Space Dimensions

- L200 **CARGO LENGTH-OPEN-FRONT** The minimum dimension measured longitudinally from the back of the front seatback at the height of the undepressed floor covering to the rearmost point on the undepressed floor covering on the open tailgate or cargo surface if the rear closure is a conventional door type tailgate at the zero "Y" plane.
- L201 **CARGO LENGTH-OPEN-SECOND** The dimension measured longitudinally from the back of the second seatback at the height of the undepressed floor covering to the rearmost point on the undepressed floor covering on the open tailgate or cargo floor surface if the rear closure is a conventional door type tailgate, at the zero "Y" plane.
- L202 **CARGO LENGTH-CLOSED-FRONT** The minimum dimension measured horizontally from the back of the front seat at the height of the undepressed floor covering to the rearmost point on the undepressed floor covering on the closed tailgate or taildoor for station wagons, trucks and mpv's at the zero "Y" plane.
- L203 **CARGO LENGTH-CLOSED-SECOND** The dimension measured horizontally from the back of the second seat at the height of the undepressed floor covering to the rearmost point on the undepressed floor covering on the closed tailgate or taildoor for station wagons, trucks and mpv's at the zero "Y" plane.
- L204 **CARGO LENGTH AT BELT-FRONT** The minimum dimension measured horizontally from the back of the front seatback at the seatback top to the foremost normal surface of the closed tailgate or inside surface of the cab backpanel at the height of the belt, on the zero "Y" plane.
- L205 **CARGO LENGTH AT BELT-SECOND** The minimum dimension measured horizontally from the back of the second seatback at the seatback top to the foremost normal surface of the closed tailgate at the height of the belt, on the zero "Y" plane.
- W201 **CARGO WIDTH-WHEELHOUSE** The minimum dimension measured laterally between the trimmed wheelhouseings at floor level. For any vehicle not trimmed, measure to the sheet metal.

Interior Car And Body Dimensions – Key Sheet
Dimensions Definitions

- W203 REAR OPENING WIDTH AT FLOOR.** The minimum dimension measured laterally between the limiting interferences of the rear opening at floor level.
- W204 REAR OPENING WIDTH AT BELT.** The minimum dimension measured laterally between the limiting interferences of the rear opening at belt height or top of pick up box.
- W205 REAR OPENING WIDTH ABOVE BELT.** The minimum dimension measured laterally between the limiting interferences of the rear opening above the belt height.
- H197 FRONT SEATBACK TO LOAD FLOOR HEIGHT.** The dimension measured vertically from the horizontal tangent to the top of the seatback to the undepressed floor covering.
- H201 CARGO HEIGHT.** The dimension measured vertically from the top of the undepressed floor covering to the headlining at the rear wheel "X" coordinate on the zero "Y" plane.
- H202 REAR OPENING HEIGHT.** The dimension measured vertically from the top of the undepressed floor covering to the upper trimmed opening on the zero "Y" plane with rear door fully open.
- H250 TAILGATE TO GROUND CURB MASS (WT.).** The dimension measured vertically from the top of the undepressed floor covering on the lowered tailgate to ground on the zero "Y" plane.
- V2 STATION WAGON**
 Measured in inches:

$$\frac{W4 \times H201 \times L204}{1728} = \text{ft}^3$$
 Measured in mm:

$$\frac{W4 \times H201 \times L204}{10^9} = \text{m}^3 \text{ (cubic meter)}$$
- V4 HIDDEN LUGGAGE CAPACITY--REAR OF FRONT SEAT**
 The total volumes of individual pieces of one set of standard luggage stowed in any hidden cargo area below the load floor rear of the front seat
- V5 TRUCKS AND MPV'S WITH OPEN AREA.**
 Measured in inches:

$$\frac{L506 \times W500 \times H503}{1728} = \text{ft}^3$$
 Measured in mm:

$$\frac{L506 \times W500 \times H503}{10^9} = \text{m}^3 \text{ (cubic meter)}$$
- V6 TRUCKS AND MPV'S WITH CLOSED AREA.**
 Measured in inches:

$$\frac{L204 \times W500 \times H505}{1728} = \text{ft}^3$$
 Measured in mm:

$$\frac{L204 \times W500 \times H505}{10^9} = \text{m}^3 \text{ (cubic meter)}$$
- V8 HIDDEN LUGGAGE CAPACITY--REAR OF SECOND SEAT.** The total volume of individual pieces of one set of standard luggage stowed in any hidden cargo area below the load floor rear of the second seat.
- V10 STATION WAGON CARGO VOLUME INDEX.**
 Measured in inches:

$$\frac{H201 \times L205 \times (W4 + W201)}{1728} = \text{ft}^3$$
 Measured in mm:

$$\frac{H201 \times L205 \times (W4 + W201)}{10^9} = \text{m}^3 \text{ (cubic meter)}$$

Hatchback – Cargo Space Dimensions

All hatchback cargo dimensions are to be taken with the front seat in full down and rear position, and the rear seat folded down. The hatchback door is in the closed position. (For electrically adjusted seats, see the manufacturer's specifications for Design "H" Point).

- L208 CARGO LENGTH AT FRONT SEATBACK HEIGHT.** The minimum horizontal dimension from the "X" plane tangent to the rearmost surface of the driver's seatback to the inside limiting interference of the hatchback door on the vehicle zero "Y" plane.
- L209 CARGO LENGTH AT FLOOR--FRONT--HATCHBACK.** The minimum horizontal dimension measured at floor level from the rear of the front seatback to the normal limiting interference of the hatchback door on the vehicle zero "Y" plane.
- L210 CARGO LENGTH AT SECOND SEATBACK HEIGHT--HATCHBACK.** The minimum dimension measured from the "X" plane tangent to the rearmost surface of second seatback or the load floor which is stowed at least one half of the H198 dimension height above the rear load floor, to the rearmost inside limiting interference on the zero "Y" plane.
- L211 CARGO LENGTH AT FLOOR--SECOND HATCHBACK.** The minimum horizontal dimension measured at floor level from the rear of the second seatback or load floor panel to the normal limiting interference of the hatchback door on the vehicle zero "Y" plane.
- H197 FRONT SEATBACK TO LOAD HEIGHT.** The dimension measured vertically from the horizontal tangent to the top of the seatback to the undepressed floor covering.
- H198 SECOND SEATBACK TO LOAD FLOOR HEIGHT.** The dimension measured vertically from the second seat back to the undepressed floor covering
- V3 HATCHBACK.**
 Measured in inches:

$$\frac{(L208 + L209) \times W4 \times H197}{1728} = \text{ft}^3$$
 Measured in mm:

$$\frac{(L208 + L209) \times W4 \times H197}{10^9} = \text{m}^3 \text{ (cubic meter)}$$
- V4 HIDDEN LUGGAGE CAPACITY--REAR OF FRONT SEAT.** The total volumes of individual pieces of one set of standard luggage stowed in any hidden cargo area below the load floor rear of the front seat.
- V11 HATCHBACK CARGO VOLUME INDEX.** Usable luggage (one (1) stand and luggage set) below floor.
 Measured in inches:

$$\frac{(L210 + L211) \times W4 \times H198}{1728} = \text{ft}^3$$
 Measured in mm:

$$\frac{(L210 + L211) \times W4 \times H198}{10^9} = \text{m}^3 \text{ (cubic meter)}$$

Index

Subject	Page No.
Aerodynamics	22
Alternator	16
Automatic Transmission Transaxle	8, 9
Axis, Steering	14
Axis, Drive, Front, Rear	2, 8, 10
Axis Shafts	10
Battery	16
Body and Miscellaneous Information	17
Brakes—Parking, Service	12, 13
Camber	15
Camshaft	3
Capacities	
Cooling System	5
Fuel Tank	6
Lubricants	
Engine Crankcase	4
Transmission Transaxle	8, 9
Rear Axle	10
Car Models	1
Car and Body Dimensions	
Width	20
Length	20
Height	20
Ground Clearance	20
Front Compartment	21
Rear Compartment	21
Luggage Compartment	21
Station Wagon - Third Seat	22
Station Wagon - Cargo Space	22
Hatchback - Cargo Space	22
Carburetor	2, 6
Caster	15
Choke, Automatic	6
Clutch - Pedal Operated	8
Coil, Ignition	16
Connecting Rods	4
Convenience Equipment	19
Cooling System	5
Crankshaft	4
Cylinders and Cylinder Head	3
Diesel Information	4
Dimension Definitions	
Key Sheet - Exterior	27, 30, 31
Key Sheet - Interior	28, 29, 31, 32, 33
Electrical System	15, 16
Emission Controls	7
Engine - General	
Bore, Stroke, Type	3
Compression Ratio	2
Displacement	2, 3
Firing Order, Cylinder Numbering	3
General Information, Power & Torque	2
Intake System	4
Power Teams	2
Exhaust System	7
Equipment Availability, Convenience	19
Fan, Cooling	5
Fiducial Marks	23
Filters - Engine Oil, Fuel System	4
Frame	17
Front Suspension	11
Front Wheel Drive Unit	10
Fuel System	6
Fuel Injection	6
Fuel Tank	6
Glass	18
Headroom - Body	21, 22
Heights - Car and Body	20
Horns	15
Horsepower - Brake	2
Ignition System	16
Inflation - Tires	13
Interior Volumes	21
Instruments	15

Subject	Page No.
Lamps and Headlamp Shape	24
Legroom	21, 22
Lengths - Car and Body	20
Leveling, Suspension	11
Lifters, Valve	4
Linings - Clutch, Brake	8, 12
Lubrication - Engine Transmission Transaxle	4, 8, 9
Luggage Compartment	21
Mass	25, 26
Models	1
Motor Starting	16
Muffler	7
Passenger Capacity	1
Passenger Mass Distribution	25
Pistons	3
Power Brakes	12
Power, Engine	2
Power Steering	14
Power Teams	2
Propeller Shaft, Universal Joints	10
Pumps - Fuel	6
Water	5
Radiator - Cap, Hoses, Core	5
Ratios - Axle, Transaxle	2, 9
Compression	2
Steering	14
Transmission Transaxle	2, 8, 9
Rear Axle	2, 9, 10
Regulator - Alternator	16
Restraint System	18
Rims	13
Rods - Connecting	4
Scrub Radius	14
Seats	17
Shock Absorbers, Front & Rear	11
Spark Plugs	16
Speedometer	15
Springs - Front & Rear Suspension	11
Stabilizer (Sway Bar) - Front & Rear	11
Starting System	16
Steering	14
Suppression - Ignition, Radio	16
Suspension - Front & Rear	11
Tail Pipe	7
Theft Protection	19
Thermostat, Cooling	5
Tires	13
Toe-In	15
Torque Converter	9
Torque - Engine	2, 8, 9
Transaxle	9
Transmission - Types	2, 8, 9
Transmission - Automatic	2, 8, 9
Transmission - Manual	2, 8, 9
Transmission - Ratios	2, 9
Tread	20
Trunk Cargo Load	1
Trunk Luggage Capacity	21
Turning Diameter	14
Unstayed Construction	17
Universal Joints, Propeller Shaft	10
Valve System	4
Voltage Regulator	16
Water Pump	5
Weights	25, 26
Wheel Alignment	15
Wheelbase	20
Wheels & Tires	13
Wheel Spindle	14
Widths - Car and Body	20
Windshield	18
Windshield Wiper and Washer	15

Car Line NOVA
Model Year 1987 Issued _____ Revised (e) _____

PERFORMANCE

		<u>5-speed Manual</u>	<u>3-speed Automatic</u>
<u>Max. speed</u>	<u>km/h</u>	_____	_____
<u>Max. cruising speed</u>	<u>km/h</u>	_____	_____
<u>Acceleration</u>			
<u>0 - 100 km/h</u>	<u>sec</u>	_____	_____
<u>0 - 400 m</u>	<u>sec</u>	_____	_____
<u>Max. permissible speed</u>			
<u>1st</u>	<u>km/h</u>	<u>38</u>	<u>56</u>
<u>2nd</u>	<u>km/h</u>	<u>71</u>	<u>101</u>
<u>3rd</u>	<u>km/h</u>	<u>110</u>	<u>-</u>
<u>4th</u>	<u>km/h</u>	<u>153</u>	<u>-</u>
<u>5th</u>	<u>km/h</u>	<u>-</u>	<u>-</u>



1
2

— — — — —



3



POWER TEAMS

Engine	Ordering Code	Displacement (Cubic Inches)	Engine Availability	Transmission Availability
ALL STATES			5-Speed Manual RPO MMS	Automatic RPO MX1
1.6 Liter 2-Bbl. L4	RPO LC9	97	Std.	EC

Std.—Standard EC—Optional at Extra Cost

Chevrolets are equipped with engines produced at facilities operated by GM car groups, subsidiaries or affiliated companies worldwide.

DIMENSIONS/SPECIFICATIONS

DIMENSIONS (Inches)	4-Door Notchback Sedan		5-Door Hatchback Sedan	
	4-Door Notchback Sedan	5-Door Hatchback Sedan	4-Door Notchback Sedan	5-Door Hatchback Sedan
EXTERIOR				
Wheelbase	95.7	95.7	50.1	50.1
Length (overall)	166.3	166.3	51.7	47.6
Width (overall)	64.4	64.4	53.8	53.8
Height (overall)	52.8	52.8	53.8	53.6
Tread—Front	56.1	56.1	23.0	23.2
Tread—Rear	55.3	55.3	—	20.0 cu. ft.
INTERIOR				
Head Room—Front	37.9	37.9	13.8 cu. ft.	—
Head Room—Rear	36.5	35.6	13.2	13.2
Leg Room—Front	42.4	42.4	—	—
Leg Room—Rear	32.0	32.0	22.06	22.53

INTERIOR (Cont'd)	4-Door Notchback Sedan		5-Door Hatchback Sedan	
	4-Door Notchback Sedan	5-Door Hatchback Sedan	4-Door Notchback Sedan	5-Door Hatchback Sedan
Hip Room—Front	50.1	50.1	50.1	50.1
Hip Room—Rear	51.7	51.7	51.7	47.6
Shoulder Room—Front	53.8	53.8	53.8	53.8
Shoulder Room—Rear	53.8	53.8	53.8	53.6
Lift-over Height	23.0	23.0	23.0	23.2
Cargo Volume Index w/Rear Seat Up	—	—	—	20.0 cu. ft.
Cargo Volume Index w/Rear Seat Down	—	—	—	35.5 cu. ft.
Usable Luggage Capacity	13.8 cu. ft.	13.8 cu. ft.	13.8 cu. ft.	—
Fuel Tank Capacity (gallons)	13.2	13.2	13.2	13.2
Curb Weight (approx. pounds)	2206	2206	2206	2253

Litro in USA.

CHEVROLET



1

2

3

