

94 Caprice

ORDERING INFORMATION

Focus Vehicle for 1994 is the Caprice Classic Sedan. This full-size, 6-passenger luxury automobile provides convenience and safety. When equipped with the recommended PEG 1 (BLA1), this model represents the best opportunity for high volume Caprice sales at your dealership.

Feature Vehicle is the Caprice Classic LS Sedan (detailed on the following sheet).

Safety and Security

■ **Driver and Passenger Air Bags**—in conjunction with seat belts, help protect driver and front passenger in certain frontal collisions ■ **New PASS-Key II Anti-Theft System**—consists of a small resistance-coded pellet in the ignition key which must match a measurement circuit in the ignition column ■ **Rear Child Security Door Locks**—manually lock to provide security against a child inadvertently opening rear doors from inside ■ **Brake/Transmission Shift Interlock (BTSI)**—prevents transmission from inadvertently being shifted out of park without first applying the foot brake ■ **Steel Safety Cage**—cradles occupants with front and rear structure crush zones helping to absorb collision impact

Performance

■ **4.3 Liter V8 Engine with Sequential Fuel Injection**—incorporates Corvette technology to improve responsiveness delivering 220 horsepower and 245 foot-pounds of torque ■ **Four-Speed Overdrive Automatic Electronic Transmission**—provides smooth, quiet shifting and excellent fuel economy ■ **Four-Wheel Anti-Lock Brakes**—help reduce wheel lockup to maintain steering control during severe braking, even on slippery roads ■ **P215/75R-15 B/W Tires**—all-season, steel-belted tires for all climates

Appearance

■ **Light Adriatic Blue Metallic, Medium Adriatic Blue Metallic, Light Gray Metallic and Bright White**—exciting new colors have been added to Caprice's exterior color choices ■ **Tinted Flush Glass**—reduces UV rays, improves aerodynamics and reduces wind noise while providing bold appearance ■ **Base Coat/Clear Coat Paint**—resists fading and provides high gloss shine for long-lasting exterior beauty ■ **Wide Body-Side Moldings**—added styling accents help prevent door dings ■ **Deluxe Full Wheel Covers**—add distinctive styling touch to overall vehicle look

Comfort and Convenience

■ **Power Windows with Driver-Side Express-Down**—allow easy operation of all windows with one-touch operation to lower driver window ■ **AM/FM Electronically Tuned Stereo Radio**—includes seek and scan features while providing high-quality sound through a four-speaker system ■ **Remote Trunk Release**—allows trunk lid to be opened from inside the vehicle ■ **Convenience Tray with Cupholder**—provides convenient storage for beverages and folds out of the way when not in use

Easy-To-Own

■ **Two-Sided Galvanized Steel**—zinc-coated outer body panels (except roof) resist corrosion and provide long-lasting exterior beauty ■ **Scotchgard™ Fabric Protector**—on seats, door panels, carpeting and floor mats; resists stains and makes cleanup easy ■ **Stainless Steel Exhaust**—includes all pipes, catalytic converter and muffler to resist corrosion ■ **CFC-Free Air Conditioning**—quickly cools interior for maximum occupant comfort and contains no ozone-depleting CFCs

RED ■ : New Feature
BLACK ■ : Focus Vehicle Feature

FEATURE VEHICLE: CAPRICE CLASSIC LS SEDAN

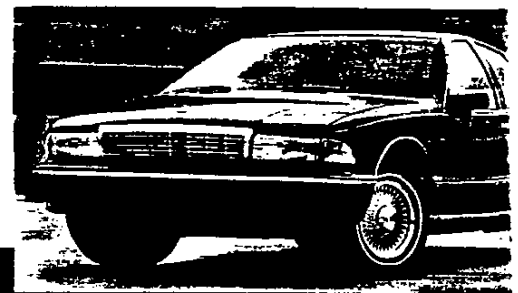

FOCUS
VEHICLE:
CAPRICE
CLASSIC
SEDAN

94 Caprice

Trim Color/Seat Style Availability

Classic Cloth available in Medium Blue, Beige, Gray and Ruby.



Standard Bench Seat with center pull-down armrest and adjustable head restraints

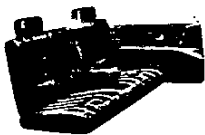

Custom Cloth available in Medium Blue, Beige, Gray and Ruby.

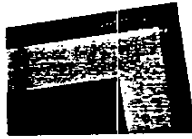

55/45 Seat with center pull-down armrest, adjustable head restraints, driver and passenger seat recliners and rear-seat center armrest



Leather available in Medium Blue, Beige, Gray and Ruby.



55/45 Seat with center pull-down armrest, adjustable head restraints, driver and passenger seat recliners and rear-seat center armrest



Optional 55/45 Seat with center pull-down armrest, adjustable head restraints, driver and passenger seat recliners



Four Most Popular Exterior Colors By Percentage

Below are the anticipated four most popular Caprice colors for 1994 based on national sales volume. They are listed for reference only. To identify the top selling colors in your area, by model, use the Retail Sales Analysis (RSA).

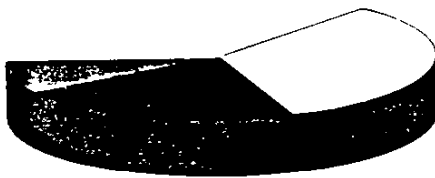

Bright White 29%
 Dark Green/Gray Metallic 11%
 Medium Garnet Red Metallic 10%
 Light Adriatic Blue Metallic 9%

Four Most Popular Exterior Colors with Corresponding Interior Color Availability

EXTERIOR	INTERIOR			
	Medium Blue	Beige	Gray	Ruby
Bright White	■	■	■	■
Dark Green/Gray Metallic		■	■	
Medium Garnet Red Metallic		■	■	■
Light Adriatic Blue Metallic	■			

NOTE: New Caprice exterior colors are Light and Medium Adriatic Blue Metallic, Light Gray Metallic and Bright White. New Caprice interior color is Medium Blue.

Wheels



Caprice Classic standard 15" full wheel cover



Caprice Classic optional 15" deluxe wheel cover

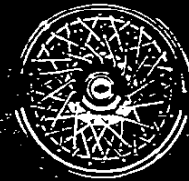

Caprice Classic and Caprice Classic LS optional 15" wire wheel cover with lock

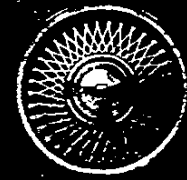

Caprice Classic LS standard 15" aluminum wheel with lock

'94 Caprice

Caprice Feature Availability

	Classic LS Sedan	Classic Sedan	Classic Wagon
4.3L SFI V8	S	S	S
5.7L SFI V8	O1	O1	O
4-Speed Automatic Transmission	S	S	S
Air Bag System, Driver and Passenger	S	S	S
4-Wheel Anti-Lock Brake System	S	S	S
Brake/Transmission Shift Interlock	S	S	S
P215/75R-15 Blackwall Radials	S4	S4	N/A
P225/75R-15 Whitewall Radials	N/A	N/A	S
P225/70R-15 Whitewall Radials	O1, or 3	O1	N/A
P235/70R-15 Blackwall Radials	O2,4	O2,4	N/A
P235/70R-15 Whitewall Radials	O2	O2	N/A
Aluminum Wheels with Locks	S	N/A	N/A
Wire Wheel Covers	O	O	O
Full Wheel Covers	N/A	S	S
Deluxe Wheel Covers	N/A	O	O
CFC-Free Air Conditioning	S	S	S
Trailer Package	O2	O2	O2
Rear Child Security Door Locks	S	S	S
PASS-Key II Anti-Theft System	S	S	S
Basecoat/Clearcoat Paint	S	S	S
Stainless Steel Exhaust	S	S	S
Scotchgard™ Fabric Protector	S	S	S

S=Standard

O=Optional

N/A=Not Available

1 Requires Ride and Handling Package

2 Requires LT1 Engine

3 Requires Trailing Package

4 Not Available with Wire Wheel Covers (N91)

Additional Information on Significant Features

- The Chevrolet Caprice has taken an important step forward by adding a new passenger air bag as standard. When used with lap/shoulder seatbelts the passenger air bag offers similar state-of-the-art protection as the driver air bag. Located in the top cover of the instrument panel above the glove box door, it deploys in less than 50 milliseconds and deflates in less than one second.
- Caprice's PASS-Key II Anti-Theft System is a completely passive system that requires no activation or deactivation before leaving the vehicle. The system consists of a small resistance-coded pellet located in the ignition key and a resistor measurement circuit in the ignition column. If a key is inserted that doesn't have the correct resistance value, the fuel system and starter are temporarily disabled.
- Caprice also offers standard 4-Wheel Anti-Lock Brakes, which minimizes the possibility of wheel lockup and results in better stability during severe braking. When wheel sensors detect an impending lockup, the control unit modulates brake pressure to the appropriate brake lines, improving steering and yaw control even on slippery surfaces.

Deletions and Rationale

- Caprice Classic LTZ Sedan has been discontinued for the 1994 model year. The Caprice Classic LS remains available as the Caprice Classic upscale model.
- Four exterior colors have been deleted for 1994. They include Silver Metallic, Light Sapphire Blue Metallic, Dark Sapphire Blue Metallic and White. Replacing these are four new colors for 1994—Medium Adriatic Blue Metallic, Light Adriatic Blue Metallic, Light Gray Metallic and Bright White.
- Caprice offers fewer PEG's for 1994, and more standard features, making ordering easier for you and the customer.

CAPRICE

REVISED: 1-10-94

1994 ORDER GUIDE

CAPRICE
PAGE 1

Prices Shown Are Manufacturer's Suggested Retail Prices (MSRP) At The Time Of Publication. These Prices Are To Be Used Only As An Aid To Inventory Management Since MSRP Prices Change Periodically. The Vehicle Price Schedule Is The Official Pricing Documentation Of Chevrolet Motor Division And Should Be Used In Discussing Vehicle Prices With Potential Buyers. The Model Prices Shown In The Order Guide Include The Destination Freight Charges.

CHEVROLET SPECIFICATIONS -- 1994 CAPRICE

MODELS PASSENGERS

Caprice Classic LS 4-Door Sedan (1BN19)	6
Caprice Classic 4-Door Sedan (1BL19)	6
Caprice Classic 4-Door 3-Seat Wagon (1BL35)	6

DIMENSIONS (inches)

EXTERIOR

Wheelbase	115.9
Length (overall)	Sedan 214.1
	Wagon 217.3
Width (overall)	Sedan 77.0
	Wagon 79.6
Height (overall)	Sedan 55.7
	Wagon 60.8

INTERIOR

Head Room-Front/Rear	Sedan 39.2/37.9
	Wagon 39.6/39.4
Shoulder Room-Front/Rear	Sedan and Wagon 63.4
Hip Room-Front/Rear	Sedan 57.0/56.9
	Wagon 56.9/57.1
Leg Room-Front/Rear	Sedan 42.2/39.5
	Wagon 42.2/38.0

LUGGAGE/CARGO CAPACITY (cu. ft.)

Luggage Compartment	20.4
	Wagon, 2nd & 3rd Seat Down 92.7
	Wagon 2nd Seat Up 54.7

RATED FUEL TANK CAPACITY (gallons)	Sedan 23.0
	Wagon 22.0

STANDARD EQUIPMENT SUMMARY

EXTERIOR

Covers, Full Wheel
 Exhaust System, Stainless Steel
 Glass, Tinted
 Mirrors, Manual Outside, LH Remote, RH Manual
 Moldings, Wide Body Side
 Paint, Base Coat/Clear Coat
 Tires, P215/75R15 Blackwall
 Windshield Wipers, Intermittent

INTERIOR

Air Bag System (Driver and Passenger)
 Air Conditioning
 Cup Holders
 Brake System, 4-Wheel Anti-Lock
 Brake/Transmission Shift Interlock
 Door Locks, Child Security, Rear
 Floor Mats, Color-Keyed Front/Rear, Carpeted
 Gage, Voltmeter and Oil Pressure

INTERIOR CONT'D

Mirror, Visor, RH Covered
 Monitor, Oil Change
 Odometer, Trip
 Pass-Key Theft Deterrent System
 Pockets, Door Map
 Radio, Electronically Tuned AM/FM Stereo Radio w/Seek-Scan, Digital Clock and Dual Front and Rear Speakers
 Seats: Standard Cloth Bench with Center Front Armrest... and Adjustable Head Restraints, Optional Cloth 55/45 Seat with Center Front Armrest, Adjustable Head Restraints, Driver and Passenger Seat Reciners
 Scotchgard Fabric Protector (Includes Seats, Door Trim and Floor Covering)
 Tilt-wheel, Adjustable Steering Column
 Transmission, 4-Speed Automatic
 Warning Light: Low Fluid

CAPRICE CLASSIC LS SEDAN ONLY

The Following Equipment is in Addition to or Replacing Items Included in The Standard Equipment Summary

EXTERIOR

Accents, Gold (Grille, Pinstriping)
 Lamps, Cornering
 Mirrors, Twin Remote Electric
 Wheels, Aluminum with Locks

INTERIOR

Cargo Net, Luggage Area
 Door Locks, Power
 Mirror, Visor LH, Covered
 Mirror, Visor RH, Illuminated
 Opener, Power Trunk
 Radio, Electronically Tuned AM/FM Stereo Radio w/Seek-Scan, Stereo Cassette Tape with Auto Reverse, Digital Clock with Coaxial Front and Extended Range Rear Speakers
 Reading Lamps, Front and Rear Compartment
 Lamps, Front and Rear, Courtesy
 Seat, Power (Driver's Side)
 Seats: Standard Custom Cloth 55/45 Seat with Center... Front and Rear Armrests, Adjustable Head Restraints, Driver and Passenger Seat Reciners and Seat Back Pockets
 Optional Leather 55/45 Seat with Center Front and Rear Armrests, Adjustable Head Restraints, Driver and Passenger Seat Reciners and Seat Back Pockets
 Speed Control, Electronic
 Windows, Power with Express Down (Driver's Side)

CHEVROLET SPECIFICATIONS --1994 CAPRICE

STANDARD EQUIPMENT SUMMARY (CONT)

CAPRICE CLASSIC WAGON ONLY

The Following Equipment is in Addition to or Replacing Items Included in The Standard Equipment Summary

EXTERIOR

Covers, Full Wheel
Rack, Luggage
Tailgate, Two-Way with Rear Wiper Washer System
Tires, P225/75R15 W/S

INTERIOR

Radio, Electronically Tuned AM/FM Stereo Radio
w/Seek-Scan, Stereo Cassette Tape with Auto Reverse,
Digital Clock with Coaxial Front and Extended Range Rear
Speakers
Seat Assist Handles, Third Seat with Integral Lights
Seats: Standard Cloth Bench with Center Front Armrest and
Adjustable Head Restraints, Optional Cloth 55/45 Seat with
Center Front Armrest, Adjustable Head Restraints, Driver
and Passenger Seat Recliners, Optional Custom Cloth
55/45 Seat with Center Front Armrests, Adjustable Head
Restraints, Driver and Passenger Seat Recliners and Seat
Back Pockets
Tailgate Window Release, Power

CAPRICE CLASSIC SEDAN

Model 1BL19

Includes Delivery, Towing & Handling Charges

MUST SPECIFY: ENGINE, TRANSMISSION, EMISSION, TIRES
MUST ORDER ONE GROUP -- NO DELETIONS ALLOWED

		BLAB	BLA1	BLA2
Base Preferred Equipment Group (Refer Standard Equipment Summary)				
0310 Preferred Equipment Group 1				
Mirrors: Twin Remote Electric			x	x
Power Door Lock System			x	x
Power Trunk Opener			x	x
Power Windows with Driver's Express Down			x	x
Speed Control, Electronic, with Resume Speed			x	x
0700 Preferred Equipment Group 2				
Electronically Tuned AM/FM Stereo Radio w/Seek-Scan				
Stereo Cassette Tape w/Auto Reverse, Digital Clock and Coaxial Front and Extended Range Rear Speakers				x
Mirror: RH Covered Visor, Illuminated				x
Power Antenna				x
Power Seat: Driver Side 6-way Adjuster				x
Reading Lamps, Dual in Rearview Mirror				x
Reading Lamps, Rear Compartment				x

ADDITIONAL OPTIONS

N.C.	R6S	Multiple Order Numbers	49.00	F41	RIDE HANDLING SUSPENSION: (Reqs GNP Tires)
N.C.	R8T	Preliminary Invoice			SEAT TRIM
250.00	S80	AXLE: Limited Slip Differential (Reqs L99 Eng) (Incls 3.23 Axle, Extra Capacity Cooling and Eng Oil Cooler) (Incl w/ B4U Sport suspension)	N.C.	C**1	Cloth Bench (N.A. w/ Group BLA2)
		BRACKET: License Plate, Front	223.00	C**5	Cloth 55/45
N.C.	K3	CARGO CONVENIENCE NET	225.00	K34	SPEED CONTROL, Electronic w/Resume Speed (Incl w/ BLA1 and BLA2)
30.00	AP9	CLIMATE CONTROL (NOTE: One of the Following Defogger Options Must Be Specified)	508.00	B4U	SPORT SUSPENSION: (Reqs LT1 Eng and QMU or QMV Tires) (Incls G80 Limited Slip Axle, QMU Tires, Leather Wrapped Steering and Trailering Package with H.D. Cooling and Eng Oil Cooler)
170.00	D49	Defogger, Rear Window: Electric		JV8	TELEPHONE: Cellular Provisions (Reqs Compatible Delco Telephone)
N.C.	R9W	Defogger, Rear Window Not Desired	45.00		TIRES
250.00	AU3	DOOR LOCK: Power (Incl w/BLA1 & BLA2)		OCV	P215/75 R15 W/S Radial
		EMISSION (Refer Emission Requirements Tab Section)	80.00	CNP	P225/70 R15 W/S (Reqs F41 Ride/Handling Suspension)
	FE9	Federal Emission Requirements	176.00	QMU	P225/70 R15 B/W Radial (Reqs LT1 Eng) (N.A. w/ N91 Wheels) (Incl w/ B4U Sport Suspension)
N.C.	NG1	NY State Emission Requirements		QMV	P225/70R15 W/S Radial (Reqs LT1 Eng) Full Size Spare Tire (Steel Wheel) w/ QMU Tires
100.00	YF5	California Emission Requirements	N.C.	N81	w/ OCV or QMV or CNP Tires
N.C.	NB8	California/NY Emission Override (Reqs FE9 Emission)		PB1	WHEELS
N.C.	NC7	Federal Emission Override (Reqs YF5 NG1 Emission)	30.00	N91	Deluxe Wheel Covers (Wire Wheel Covers & Locks)
		ENGINE	60.00		
N.C.	L99	4.3 Liter SFI V8 (Base)	65.00		
325.00	LT1	5.7 Liter SFI V8 (Reqs B4U Sport Suspension) (Incl Trans Oil Cooler) (N.A. w/ BLAB)	70.00		
141.00	D84	PAINT: CUSTOM TWO-TONE	215.00		
61.00	D90	PINSTRIPING: BODY SIDE AND REAR (N.A. D84 Two-Tone Paint)			
		RADIO EQUIPMENT			
V.P.S.	JM6	Electronically Tuned AM/FM Stereo Radio w/Seek-Scan, Stereo Cassette Tape w/Auto Reverse, Digital Clock and Coaxial Front and Extended Range Rear Speakers (Incl w/ Group BLA2)			
V.P.S.	J1C	Electronically Tuned AM/FM Stereo Radio w/Seek-Scan, Digital Clock, Compact Disc Player, Coaxial Front and Extended Range Rear Speakers and Delco-Loc II			

CAPRICE CLASSIC SEDAN

COLOR AND TRIM SELECTION

PLEASE NOTE: The Exterior Paint and Interior Trim Combinations Shown Below are the Only Combinations that are Available.

Interior Trim Color		Med Blue	Med Beige	Gray	Ruby
MODEL	SEAT TYPE				
1BL19	Cloth Bench	CDD1	CEE1	COQ1	CPF1
	Cloth 55, 45	CDD5	CEE5	COQ5	CPF5

CUSTOM TWO-TONE PAINT

(D84 Must Be Specified in "Plus" (-) Option Section of Order Worksheet)

Exterior Paint Color	Color Code 1	Color Code 2	Med Blue	Med Beige	Gray	Ruby
Black & Gray, Med (Met)	41	37			x	x
Blue, Lt Adriatic (Met) & Gray, Med (Met)	36	87	x			
Blue Med Adriatic (Met) & Gray, Med (Met)	30	37	x		x	
Cherry, Dk (Met) & Gray, Med (Met)	77	87			x	x
Green-Gray, Dk (Met) & Gray, Lt (Met)	18	14			x	
Red, Med Garnet (Met) & Gray, Med (Met)	72	37			x	x
White, Bright & Gray, Med (Met)	16	37	x	x	x	x

SOLID PAINT APPLICATION

Exterior Paint Color	Color Code 1	Color Code 2	Med Blue	Med Beige	Gray	Ruby
Black	41	41		x	x	x
Blue, Lt Adriatic (Met)	36	36	x			
Blue, Med Adriatic (Met)	30	30	x		x	
Cherry, Dk (Met)	77	77		x	x	x
Driftwood, Lt (Met)	33	33		x		
Gray, Lt (Met)	14	14	x		x	x
Green-Gray Dk (Met)	18	18		x	x	
Purple Pearl (Met)	91	91		x	x	
Red, Med Garnet (Met)	72	72		x	x	x
White, Bright	16	16	x	x	x	x

POWER TEAMS

ENGINE OPTION CONDITION	AXLE RATIO	
	*2.73	2.93
WITH FE9 FEDERAL EMISSIONS		
L99 MX0	Std	----
LT* MX0	----	Std
WITH YF5 CALIFORNIA or NG1 NY STATE EMISSIONS		
L99 MX0	Std	----
LT* MX0	----	Std

*3.23 Axle Ratio with G80 Limited Slip Axle

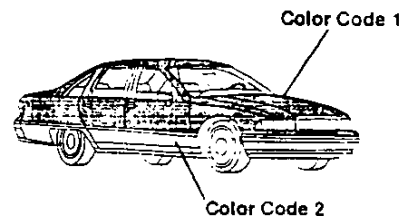

CAPRICE CLASSIC LS SEDAN

102,168.00 Model 1BN19

*Includes Destination and Handling Charges

MUST SPECIFY ENGINE, TRANSMISSION, EMISSION, TIRES
MUST ORDER ONE GROUP -- NO DELETIONS ALLOWED

	Base Preferred Equipment Group (Refer Standard Summary Page)	BNAB	BNA1
150.00	Preferred Equipment Group 1		
	Automatic Day/Night Rearview Mirror		x
	Defogger, Rear Window with Heated Outside Rearview Mirrors		x
	Power Antenna		x
	Power Seat, Passenger Side 6-way Adjuster		x
	Remote Keyless Entry w/Trunk Release		x
	Twilight Sentinel Headlamp System		x

ADDITIONAL OPTIONS

	ACKNOWLEDGEMENTS			
N.C.	R8S	Multiple Order Numbers	49.00	F41 RIDE/HANDLING SUSPENSION: (Reqs QNP Tires)
N.C.	R8T	Preliminary Invoice		SEAT TRIM
150.00	B30	AXLE: Limited Slip Differential (Reqs L99 Eng, Incis 3.23 Axle, Extra Capacity Cooling and Eng Oil Cooler) (Incl W/ B4U Sport Suspension)	1.00 345.00 508.00	F115 Custom Cloth 55.45 A115 Leather 65.45 (N/A w/ Group BNAB)
N.C.	VK3	BRACKET: License Plate, Front		B4U SPORT SUSPENSION: (Reqs LT1 Eng and QMU or QMV Tires) (Incls G80 Limited Slip Axle, QMU Tires, Leather Wrapped Steering Wheel and Trailing Package with H. D. Cooling and Eng Oil Cooler)
	CLIMATE CONTROL			TELEPHONE: Cellular Provisions (Reqs Compatible Delco Telephone)
	(Note: One of the Following Defogger Options must be Specified)			TIRES
205.00	C49	Defogger, Rear Window, Electric (Incls Electronically Heated Outside Rearview Mirrors (Incl w/Group BNA1))	45.00	QCV P215/75 R15 W/S (Radial)
N.C.	R9W	Defogger, Rear Window not Desired (N/A w/Group BNA1)	80.00	QNP P225/70 R15 W/S (Radial) (Reqs F41 Ride/Handling Suspension)
	EMISSION: (Refer Emission Requirement Tab Section)		N.C.	QMU P235/70 R15 B/W (Radial) (Reqs LT1 Eng) (N/A N91 Wheel Covers) (Incl w/ B4U Sport Suspension)
N.C.	FE9	Federal Emission Requirements		QMV P235/70R15 W/S (Radial) (Reqs LT1 Eng)
N.C.	NG1	NY State Emission Requirements		N81 Full Size Spare Tire (w/Base Aluminum Wheel)
100.00	YF5	California Emission Requirements	90.00	w/ QMU Tires
N.C.	NB8	California/NY Emission Override (Reqs FE9 Emission)		w/ QCV or QMV or QNP Tires
N.C.	NC7	Federal Emission Override (Reqs YF5 NG1 Emission)	110.00 115.00	N81 Full Size Spare Tire (w/N91 Wheel Cover) w/ QMU Tires
	ENGINE			w/ QCV or QMV or QNP Tires
N.C.	L99	4.3 Liter SFI V8 (Base)	60.00	N91 WHEELS: Wire Wheel Covers w/Locks
325.00	LT1	5.7 Liter SFI V8 (Reqs B4U Sport Suspension) (Incl Trans Oil Cooler)	55.00 (-61.00)	
256.00	J1C	RADIO EQUIPMENT: Electronically Tuned AM/FM Stereo Radio w/Seek-Scan, Digital Clock, Compact Disc Player, Coaxial Front and Extended Range Rear Speakers and Delco-Loc III		

CAPRICE CLASSIC LS SEDAN

COLOR AND TRIM SELECTION

PLEASE NOTE: The Exterior Paint and Interior Trim Combinations Shown Below are the Only Combinations that are Available.

Interior Trim Color		Med Blue	Med Beige	Gray	Ruby
MODEL	SEAT TYPE				
1BN19	Custom Cloth 55.45	FDD5	FEE5	FQQ5	FFF5
	Leather 55.45	ADD5	AEE5	AQQ5	AFF5

SOLID PAINT APPLICATION

Exterior Paint Color	Color Code 1	Color Code 2	Med Blue	Med Beige	Gray	Ruby
Black	41	41		x	x	x
Blue, Lt Adriatic (Met)	36	36	x			
Blue, Med Adriatic (Met)	30	30	x		x	
Cherry, Dk (Met)	77	77		x	x	x
Driftwood, Lt (Met)	33	33		x		
Gray, Lt (Met)	14	14	x		x	x
Green-Gray, Dk (Met)	18	18		x	x	
Purple Pearl (Met)	91	91		x	x	
Red, Med Garnet (Met)	72	72		x	x	x
White, Bright	16	16	x	x	x	x

POWER TEAMS

ENGINE OPTION CONDITION	AXLE RATIO	
	*2.73	2.93
WITH FE9 FEDERAL EMISSIONS		
L99 MX0	Std	----
LT1 MX0	----	Std
WITH YF5 CALIFORNIA or NG1 NY STATE EMISSIONS		
L99 MX0	Std	----
LT1 MX0	----	Std

*3.23 Axle Ratio with G80 Limited Slip Axle

CAPRICE CLASSIC WAGON

121,919.00 Model 1BL35

*Includes Destination and Handling Charges

**MUST SPECIFY: ENGINE, TRANSMISSION, EMISSION
MUST ORDER ONE GROUP -- NO DELETIONS ALLOWED**

	Base Preferred Equipment Group (Refer Standard Equipment Summary)	BWAB	BWA1	BWA2
1273.00	Preferred Equipment Group 1 Mirrors: Twin Remote Electric Power Seat: Driver Side 6-Way Adjuster Power Door Lock System (Including Tailgate) Power Windows w/Driver's Express Down Speed Control: Electronic with Resume Speed		x x x x x	x x x x
2146.00	Preferred Equipment Group 2 Automatic Day/Night Rearview Mirror with Dual Reading Lamps Defogger: Rear Window, with Heated Outside Rearview Mirrors Mirror, RH Covered Visor, Illuminated Power Antenna Power Seat: Passenger's Side 6-way Adjuster Rear Compartment Cover, Security Rear Compartment Decor, Deluxe Reading Lamps, Rear Compartment			x x x x x x x x

ADDITIONAL OPTIONS

ACKNOWLEDGEMENTS		SEAT TRIM	
N.C.	R8S Multiple Order Numbers	N.C.	C**1 Cloth Bench (Reqs BWAB)
N.C.	R8T Preliminary Invoice	223.00	C**5 Cloth 55.45 (N/A Group BWA2)
100.00	G80 AXLE: Rear, Limited Slip Differential (Reqs V92 Trailering Package)	342.00	F**5 Custom Cloth 55.45 (N/A w/BWAB and BWA1)
N.C.	VK3 BRACKET: License Plate, Front	225.00	K34 SPEED CONTROL: Electronic with Resume Speed (Incl w/Groups BWA1 and BWA2)
30.00	AP9 CARGO CONVENIENCE NET	75.00	G67 SUSPENSION: Auto Leveling (N/A w/BWAB and BWA1)
	CLIMATE CONTROL		
	(Note: One of the Following Defogger Options must be Specified)	65.00	N81 TIRE: Spare, Full Size
170.00	C49 Defogger, Rear Window: Electric (w/ BWAB)	21.00	V92 TRAILERING PKG: (Incls H.D. Cooling)
205.00	C49 Defogger, Rear Window: Electric (w/ BWA1) (Incl w/ BWA2)		WHEELS
	(Incls Electrically Heated Outside Rearview Mirrors)	70.00	PB1 Deluxe Wheel Covers
N.C.	R9W Defogger, Rear Window not Desired (N/A w/ BWA2)	215.00	N91 Wire Wheel Covers (w/ Locks)
325.00	AU3 DOOR LOCKS: Power (Incl Tailgate Lock) (Incl w/BWA1 and BWA2)	595.00	BX3 WOODGRAIN EXTERIOR: (N/A D84 Two-Tone Paint or D90 Pinstriping)
N.C.	LT1 ENGINE: 5.7 Liter SFI V8 (Incl Trans Oil Cooler) (Base)		
	EMISSION: (Refer Emission Requirement Tab Section)		
N.C.	FE9 Federal Emission Requirements		
N.C.	NG1 NY State Emission Requirements		
100.00	YF5 California Emission Requirements		
N.C.	NB8 California/NY Emission Override (Reqs FE9 Federal Emission)		
N.C.	NC7 Federal Emission Override (Reqs YF5/NG1 Emission)		
141.00	D84 PAINT: Custom Two-Tone (N.A BX3 Woodgrain)		
61.00	D90 PINSTRIPING: Body Side and Rear (N.A BX3 Woodgrain)		
	RADIO EQUIPMENT		
256.00	U1C Electronically Tuned AM/FM Stereo Radio w/Seek-Scan, Digital Clock, Compact Disc Player, Coaxial Front and Extended Range Rear Speakers and Delco-Loc II		

CAPRICE CLASSIC WAGON

COLOR AND TRIM SELECTION

PLEASE NOTE: The Exterior Paint and interior Trim Combinations Shown Below are the Only Combinations that are Available.

Interior Trim Color	Med Blue	Med Beige	Gray	Ruby
---------------------	----------	-----------	------	------

MODEL	SEAT TYPE				
1BL35	*Cloth Bench	CDD1	CEE1	CGG1	CFE1
	*Cloth 55:45	CDD5	CEE5	CGG5	CFE5
	# *Custom Cloth 55:45	FDD5	FEF5	FOO5	FFF5

*Third Seat Trim is Vinyl

Incis LH Covered Visor Mirror and Cargo Retaining Net

CUSTOM TWO-TONE PAINT (N/A WOODGRAIN EXTERIOR)

(D84 Must Be Specified in "Plus" (-) Option Section of Order Worksheet)

Exterior Paint Color	Color Code 1	Color Code 2	Med Blue	Med Beige	Gray	Ruby
Black & Gray, Med (Met)	41	87			x	x
Blue, Lt Adriatic (Met) & Gray, Med (Met)	36	87	x			
Blue, Med Adriatic (Met) & Gray, Med (Met)	30	87	x		x	
Cherry, Dk (Met) & Gray, Med (Met)	77	87			x	x
Green-Gray, Dk (Met) & Gray, Lt (Met)	18	14			x	
Red, Med Garnet (Met) & Gray, Med (Met)	72	87			x	x
White, Bright & Gray, Med (Met)	16	87	x	x	x	x

SOLID PAINT APPLICATION

Exterior Paint Color	Color Code 1	Color Code 2	Med Blue	Med Beige	Gray	Ruby
Black	41	41		x	x	x
Blue, Lt Adriatic (Met)	36	36	x			
Blue, Med Adriatic (Met)	30	30	x		x	
Cherry, Dk (Met)	77	77		x	x	x
Driftwood, Lt (Met)	33	33		x		
Gray Lt (Met)	14	14	x		x	x
Green-Gray, Dk (Met)	18	18		x	x	
Purple Pearl (Met)	91	91		x	x	
Red, Med Garnet (Met)	72	72		x	x	x
White, Bright	16	16	x	x	x	x

POWER TEAMS

ENGINE OPTION CONDITION	AXLE RATIO
	*2.56
WITH FE9 FEDERAL EMISSIONS	
LT1 MX0	Std
WITH YF5 CALIFORNIA or NG1 NY STATE EMISSIONS	
LT1 MX0	Std

*2.93 Axle Ratio with V92 Trailering Pkg

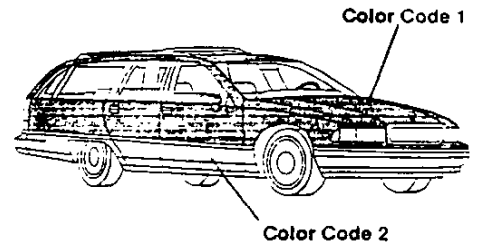

REVISED: 1-10-94

1994 ORDER GUIDE

CAPRICE
PAGE 9

Prices Shown Are Manufacturer's Suggested Retail Prices (MSRP) At The Time Of Publication. These Prices Are To Be Used Only As An Aid To Inventory Management Since MSRP Changes Periodically. The Vehicle Price Schedule Is The Official Pricing Documentation Of Chevrolet Motor Division And Should Be Used In Discussing Vehicle Prices With Potential Buyers. The Model Prices Shown In The Order Guide Include The Destination Freight Charges.

CAPRICE CLASSIC

SOLID/TWO-TONE PAINT APPLICATION

STRIPE COLOR ONLY WHEN D90 STRIPE IS ORDERED ON CAPRICE CLASSIC SEDANS AND WAGON. GOLD STRIPE COLOR INCLUDED WITH CAPRICE CLASSIC LS. MOLDINGS ARE BODY COLOR WITH SOLID PAINT EXTERIOR. MOLDING COLOR ON TWO-TONE PAINT SAME AS LOWER BODY COLOR. ST= MED GRAY, LT=LT GRAY

Color Code 1 Exterior Paint		INTERIOR TRIM COLOR			
		Med Blue	Med Beige	Gray	Ruby
Black 41	Stripe		Gold	Red	Red
Blue, Lt Adriatic (Met) 36	Stripe	Dk Blue			
Blue, Med Adriatic (Met) 30	Stripe	Lt Blue		Lt Gray	
Cherry, Dk (Met) 77	Stripe		Gold	Lt Gray	Lt Gray
Driftwood, Lt (Met) 33	Stripe		Dk Gold		
Grav. Lt (Met) 14	Stripe	Dk Blue		Gray	Red
Green-Gray, Dk (Met) 18	Stripe		Gold	Lt Gray	
Purple Pearl (Met) 91	Stripe		Gold	Lt Gray	
Red, Med Garnet (Met) 72	Stripe		Gold	Lt Gray	Lt Gray
White, Bright 16	Stripe	Dk Blue	Gold	Red	Red

5.7L V8

LT1

The performance of the exciting small block V8 LT1 equals or exceeds world-class V8 standards for mass, size, fuel consumption, emissions, and cold start.

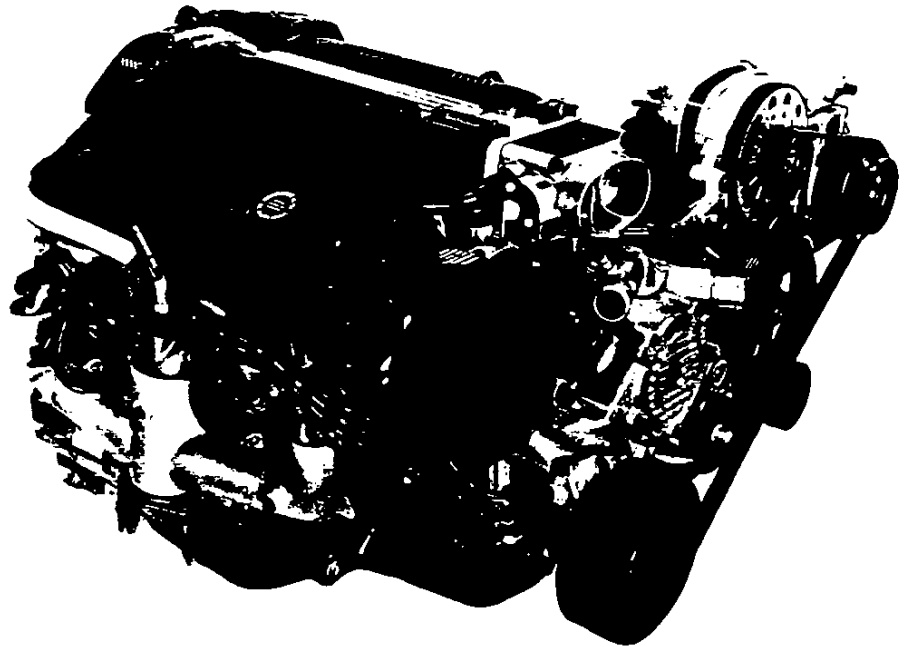

Features/Benefits

- Sequential-port electronic fuel injection precisely delivers fuel directed with state-of-the-art flow control and spray pattern.
- Overhead valve configuration produces high torque at lower rpm for excellent take-off power and quieter operation.
- A low-restriction three-way catalyst on each cylinder bank maintains superior exhaust flow.
- A unique pressurized reverse-flow cooling system channels cooler water to the cylinder heads, creating optimum conditions for greater spark control and lower cylinder friction.
- Dual oxygen sensors on each cylinder bank feed information to the advanced engine control system for optimum control of fuel/air mixture.
- Gear-driven water pump ensures coolant flow even if accessory belt breaks.
- A short-runner intake manifold with multi-port fuel injection, high compression pistons, free-flowing aluminum cylinder heads, and a hydraulic roller camshaft are all part of the new small block's "power package."
- Opti-spark system is extremely precise, enabling spark control adjustments to be accomplished several times each second.
- Powerful ignition system offers superb cold start-ability. The LT1 starts within six-tenths of a second, even at 20 degrees below zero.
- Heart-shaped combustion chambers enhance combustion efficiency.
- The LT1 rpm range is increased 800 to 1,000 revs beyond normal overhead valve engines, giving the LT1 the low-end punch of an overhead engine and the high-speed responsiveness of an overhead cam engine.

Product Specifications

Type:

5.7L V8

Displacement:

350 cu. in. (5.737 ltr)

Compression Ratio:

10.5:1

Valve Configuration:

Overhead Valves

Manufactured:

Flint, Michigan

Valve Lifters:

Hydraulic

Firing Order:

1-8-4-3-6-5-7-2

Bore × Stroke:

4.00 × 3.48 in. (101.60 × 88.39 mm)

Fuel System:

Sequential-Port Fuel Injection

Horsepower:

260 hp @ 5000 rpm (B)

260 hp @ 5000 rpm (D)

275 hp @ 5000 rpm (F)

300 hp @ 5000 rpm (Y)

Torque:

330 lb-ft @ 3200 rpm (B)

335 lb-ft @ 3200 rpm (D)

325 lb-ft @ 2000 rpm (F)

340 lb-ft @ 3600 rpm (Y)

Materials:

Block:

Cast Iron

Cylinder Head:

Cast Iron (B,D)

Cast Aluminum (F,Y)

Intake Manifold:

Cast Aluminum

Exhaust Manifold:

Cast Iron

Main Bearing Caps:

Cast Iron

Crankshaft:

Cast Iron

Camsnait:

Cast Iron

- B = CHEVROLET CAPRICE
- D = CADILLAC FLEETWOOD
- F = CHEVROLET CAMARO
- Y = CHEVROLET CORVETTE

Information may vary with application. All specifications listed are based on the latest product information available at the time of publication. The right is reserved to make changes at any time without notice.

5.7L V8 Engine (LT1)

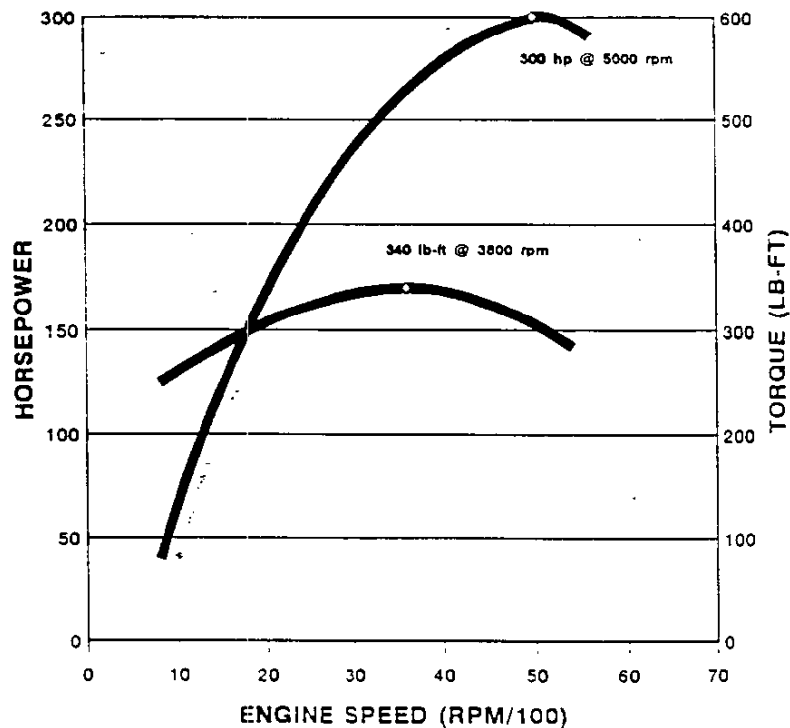

MANUFACTURERS MOTOR VEHICLE SPECIFICATIONS

METRIC (U.S. Customary)

1994

Manufacturer	CHEVROLET MOTOR DIVISION GENERAL MOTORS CORPORATION	Vehicle Line	CAPRICE CLASSIC SEDAN
Mailing Address	30007 VAN DYKE WARREN, MI 48090-9065	Issued	SEPTEMBER, 1993
		Revised	

Direct questions concerning these specifications to the manufacturer listed above.

The information contained herein is prepared, distributed by, and is solely the responsibility of the vehicle manufacturing company to whose products it relates. This specification form was developed by the vehicle manufacturing companies under the auspices of the American Automobile Manufacturers Association.

The General Specifications herein are those in effect at date of compilation and are subject to change without notice or incurring obligation by the manufacturer.

MVMA

Motor Vehicle Manufacturers Association
of the United States, Inc.

Blank Forms Provided by Technical Affairs Division

MVMA Specifications

METRIC (U.S. Customary)

Table of Contents

1	Vehicle Models/Origin	∅ Indicates Format Change From Previous Year
2	Power Teams	
3	Engine	
4	Lubrication System	
4	Diesel Information	
5	Cooling System	
6	Fuel System	
7	Vehicle Emission Control	
7	Exhaust System	
8-10	Transmission, Axles and Shafts	
11	Suspension	
12-13	Brakes, Tires and Wheels	
14	Steering	
15-16	Electrical	
17	Body – Miscellaneous Information	
17	Frame	
18	Restraint System	
18	Glass	
18	Headlamps	
19	Climate Control System	
20-21	Convenience Equipment	
21	Trailer Towing	
22-24	Vehicle Dimensions	
25	Vehicle Fiducial Marks	
26	Vehicle Mass (Weight)	
27	Optional Equipment Differential Mass (Weight)	
28-34	Vehicle Dimensions Definitions - Key Sheets	
35	Index	

NOTE:

1. This form uses both SI metric units and U.S. Customary units. The metric unit of measure is presented first, and the U.S. Customary unit follows in parentheses.
2. UNLESS OTHERWISE INDICATED:
 - a. Specifications apply to standard models without optional equipment. Significant deviations are noted.
 - b. Nominal design dimensions are used throughout these specifications.
 - c. All linear dimensions are in millimeters (inches), and all mass (weight) specifications are in kilograms (pounds).
3. The General Specifications herein are those in effect at date of compilation and are subject to change without notice or incurring obligation by the manufacturer.
4. Additional Vehicle Dimensions (based in part on SAE J1100 "Motor Vehicle Dimensions") may be available from the manufacturer.

MVMA Specifications

Vehicle Line CAPRICE CLASSIC SEDAN
 Model Year 1994 Issued 9-93 Revised(*) _____

METRIC (U.S. Customary)

Vehicle Origin

Design & development (company)	Midsize Car Division
Where built (country)	U.S.A.
Authorized U.S. Sales marketing representative	Chevrolet Motor Division

Vehicle Models

Model Description & Drive (FWD/RWD/AWD/4WD)*	Make, Vehicle Models, Series, Body Type (Mfg's Model Code)	No. of Designated Seating Positions (Front/Rear)	Max. Trunk/Cargo Load-Kilograms (Pounds)	EPA Fuel Economy (City/Hwy)
CAPRICE CLASSIC				
4-Door Notchback Sedan (RWD)	1BL19	6 (3/3)	92.4 (203.6)	18/26
CAPRICE CLASSIC LS				
4-Door Notchback Sedan (RWD)	1BN19 (1BL19 w/Z09)	6 (3/3)	92.4 (203.6)	18/26

* FWD - Front Wheel Drive RWD - Rear Wheel Drive AWD - All Wheel Drive 4WD - Four Wheel Drive

MVMA Specifications

Vehicle Line CAPRICE CLASSIC SEDAN
 Model Year 1994 Issued 3-93 Revised _____

METRIC (U.S. Customary) Power Teams

SAE J1349 Net bhp (brake hrspwr) and Net Torque corrected to 77 deg. F / 25 deg. C and 29.61 in. Hg/100 kPA atmos. press.

		A	B	C	D	
E N G I N E	Engine Code	L99	L99	LT1	LT1	
	Displacement Liters (cu. in.)	4.3 (265)	4.3 (265)	5.7 (350)	5.7 (350)	
	Induction system (FI, Carb. etc.)	Sequential Fuel Injection	Sequential Fuel Injection	Sequential Fuel Injection	Sequential Fuel Injection	
	Compression ratio	9.8:1	9.8:1	10.5:1	10.5:1	
	SAE Net at RPM	Power kW (bhp)	149 (200) @ 5200	149 (200) @ 5200	194 (260) @ 5000	194 (260) @ 5000
		Torque Newton meters (lb.ft.)	332 (245) @ 2400	332 (245) @ 2400	447 (330) @ 3200	447 (330) @ 3200
Exhaust Single, dual		Single	Single	Dual	Dual	
T R A N S	Transmission/ Transaxle	M30 Auto Transmission 4-Speed	M30 Auto Transmission 4-Speed	M30 Auto Transmission 4-Speed	M30 Auto Transmission 4-Speed	
	Effective Final Drive/ Axle Ratio (std. first)	2.73	3.23	2.93	3.08	

Series Availability		Power Teams (A - B - C - D)	
Model	Code	Standard	Optional
CAPRICE CLASSIC			
4-Dr. Notchback Sedan	1BL19	A	B, C
CAPRICE CLASSIC LS			
4-Dr. Notchback Sedan	1BN19	A	B, C
CAPRICE (POLICE VEHICLES SEO 9C1)			
4-Dr. Notchback Sedan	1BL19	D	--

MVMA Specifications

Vehicle Line CAPRICE CLASSIC SEDAN
 Model Year 1994 Issued 9-93 Revised _____

METRIC (U.S. Customary)

Engine Description	4.3 LITER V8 (265 CID)
Engine Code	SEQUENTIAL FUEL INJECTION RPO L99

ENGINE - GENERAL

Type & description (inline, V, angle, flat, location, front, mid, rear, transverse, longitudinal, sohc, dohc, ohv, hemi, wedge, pre-chamber, etc.)	90 Deg. V Front Longitudinal	
Manufacturer	General Motors Powertrain Division	
No. of cylinders	8	
Bore	85.67 mm (3.373 in.)	
Stroke	76.2 mm (3.00 in.)	
Bore spacing (C/L to C/L)	111.76 mm (4.40 in.)	
Cyl blk matl & mass kg (lbs.) machined	Cast Iron	
Cylinder block deck height	229.4 mm (9.025 in.)	
Cylinder block length	506.2 mm (19.93 in.)	
Deck clearance (minimum) (above or below block)	.025 Below	
Cyl. head material & mass kg (lbs.)	Cast Iron	
Cylinder head volume cu. cm. (cu. in.)		
Cylinder liner material	Not Applicable	
Head gasket thickness (compressed)	1.245 mm (0.049 in.)	
Minimum combustion chamber total volume cu. cm. (cu. in.)		
Cyl. no. system (front to rear)*	L. Bank	1-3-5-7
	R. Bank	2-4-6-8
Firing order	1-8-4-3-6-5-7-2	
Intake manifold matl & mass kg (lbs.)**	Cast Aluminum	
Exh. manifold matl & mass kg (lbs.)**	Cast Iron	
Knock sensor (number & location)	2 - One Each Side Of Cylinder Case	
Fuel required unleaded, diesel, etc.	Unleaded	
Fuel antiknock index (R + M) / 2		
Engine mounts	Quantity	2
	Matl and type (elastomeric, hydroelastic, hydraulic damper, etc.)	Elastomeric
	Added isolation (sub-frame, crossmember, etc.)	Not Applicable
Total dressed engine mass (wt) dry***	267.46 kg. (589.6 lbs.)	

Engine - Pistons

Material & mass, g (weight, oz.) - piston only	Cast Aluminum
--	---------------

Engine Camshaft

Location	In Cylinder Block "V" Above Crankshaft	
Material & mass kg (weight, lbs.)	Steel	
Drive type	Chain/belt	Chain
	Width/pitch	

*Rear of engine - drive takeoff. View from drive takeoff end to determine left & right side of engine.
 **Finished state.
 ***Dressed engine mass (weight) includes the following:

MVMA Specifications

Vehicle Line CAPRICE CLASSIC SEDAN
 Model Year 1994 issued 9-93 Revised _____

METRIC (U.S. Customary)

Engine Description	5.7 LITER V8 (350 CID)
Engine Code	SEQUENTIAL FUEL INJECTION RPO LT1

ENGINE - GENERAL

Type & description (inline, V, angle, flat, location, front, mid, rear, transverse, longitudinal, sohc, dohc, ohv, hemi, wedge, pre-chamber, etc.)	90 Deg. V Front Longitudinal	
Manufacturer	General Motors Powertrain Division	
No. of cylinders	8	
Bore	101.6 mm (4.0 in.)	
Stroke	86.40 mm (3.48 in.)	
Bore spacing (C/L to C/L)	111.8 mm (4.40 in.)	
Cyl block matl & mass kg(lbs.)(machined)	Cast Iron	
Cylinder block deck height	229.4 mm (9.025 in.)	
Cylinder block length	506.2 mm (19.93 in.)	
Deck clearance (minimum) (above or below block)	.025 Below	
Cyl. head material & mass kg (lbs.)	Cast Iron	
Cylinder head volume cu. cm. (cu. in.)		
Cylinder liner material	Not Applicable	
Head gasket thickness (compressed)	1.245 mm (.049 in.)	
Minimum combustion chamber total volume cu. cm. (cu. in.)		
Cyl. no. system (front to rear)*	L. Bank	1-3-5-7
	R. Bank	2-4-6-8
Firing order	1-8-4-3-6-5-7-2	
Intake manifold matl & mass kg (lbs.)**	Cast Aluminum	
Exh. manifold matl & mass kg (lbs.)**	Cast Iron	
Knock sensor (number & location)	2 - One Each Side Of Cylinder Case	
Fuel required unleaded, diesel, etc.	Unleaded	
Fuel antiknock index (R + M) / 2		
Engine mounts	Quantity	2
	Matl and type (elastomeric, hydroelastic, hydraulic damper, etc.)	Elastomeric
	Added isolation (sub-frame, crossmember, etc.)	Not Applicable
Total dressed engine mass (wt) dry***	273.24 kg. (602.4 lbs.)	

Engine - Pistons

Material & mass, g (weight, oz.) - piston only	Cast Aluminum
--	---------------

Engine Camshaft

Location	In Cylinder Block "V" Above Crankshaft	
Material & mass kg (weight, lbs.)	Steel	
Drive type	Chain/belt	Chain
	Width/pitch	

*Rear of engine - drive takeoff. View from drive takeoff end to determine left & right side of engine.
 **Finished state.
 ***Dressed engine mass (weight) includes the following:

MVMA Specifications

Vehicle Line CAPRICE CLASSIC POLICE SEDAN (SEO 9C1)
 Model Year 1994 Issued 9-93 Revised _____

METRIC (U.S. Customary)

Engine Description
 Engine Code

5.7 LITER V8 (350 CID)
 SEQUENTIAL FUEL INJECTION RPO LT1

ENGINE - GENERAL

Type & description (inline, V, angle, flat, location, front, mid, rear, transverse, longitudinal, sohc, dohc, ohv, hemi, wedge, pre-chamber, etc.)

90 Deg. V Front Longitudinal

Manufacturer

General Motors Powertrain Division

No. of cylinders

8

Bore

101.6 mm (4.0 in.)

Stroke

86.40 mm (3.48 in.)

Bore spacing (C/L to C/L)

111.8 mm (4.40 in.)

Cyl block matl & mass kg(lbs.)^xmachined

Cast Iron

Cylinder block deck height

229.4 mm (9.025 in.)

Cylinder block length

506.2 mm (19.93 in.)

Deck clearance (minimum) (above or below block)

.025 Below

Cyl. head material & mass kg (lbs.)

Cast Iron

Cylinder head volume cu. cm. (cu. in.)

Cylinder liner material

Not Applicable

Head gasket thickness (compressed)

1.245 mm (.049 in.)

Minimum combustion chamber total volume cu. cm. (cu. in.)

Cyl. no. system (front to rear)*

L. Bank

1-3-5-7

R. Bank

2-4-6-8

Firing order

1-8-4-3-6-5-7-2

Intake manifold matl & mass kg (lbs.)**

Cast Aluminum

Exh. manifold matl & mass kg (lbs.)**

Cast Iron

Knock sensor (number & location)

2 - One Each Side Of Cylinder Case

Fuel required unleaded, diesel, etc.

Unleaded

Fuel antiknock index (R + M) / 2

Engine mounts

Quantity

2

Matl and type (elastomeric, hydroelastic, hydraulic damper, etc.)

Elastomeric

Added isolation (sub-frame, crossmember, etc.)

Not Applicable

Total dressed engine mass (wt) dry***

273.24 kg. (602.4 lbs.)

Engine - Pistons

Material & mass, g (weight, oz.) - piston only

Cast Aluminum

Engine Camshaft

Location

In Cylinder Block "V" Above Crankshaft

Material & mass kg (weight, lbs.)

Steel

Drive type

Chain/belt

Chain

Width/pitch

*Rear of engine - drive takeoff. View from drive takeoff end to determine left & right side of engine.

**Finished state.

***Dressed engine mass (weight) includes the following:

MVMA Specifications

Vehicle Line CAPRICE CLASSIC SEDAN
 Model Year 1994 Issued 9-93 Revised _____

METRIC (U.S. Customary)

Engine Description	4.3 LITER V8 (265 CID)
Engine Code	SEQUENTIAL FUEL INJECTION RPO L99

Engine - Valve System

Hydraulic lifters (std., opt., n.a.)	Hydraulic	
Valves	Number intake/exhaust	8/8
	Head O.D. intake/exhaust	46.74 (1.84) / 38.10 (1.50)

Engine - Connecting Rods

Material & mass kg., (weight, lbs.)*	Forged Steel
Length (axes centerline to centerline)	

Engine - Crankshaft

Material & mass kg., (weight, lbs.)*	Cast Iron	
End thrust taken by bearing (no.)	5	
Length & number of main bearings	5	
Seal (material, one, two piece design, etc.)	Front	Fluorelastomer/One Piece Lip Seal
	Rear	Fluorelastomer/One Piece Lip Seal

Engine - Lubrication System

Normal oil pressure kPa (psi) @ eng rpm	41 (6) @ 1000 / 124 (18) @ 2000 / 165 (24) @ 4000 Hot
Type oil intake (floating, stationary)	Stationary
Oil filter sys. (full flow, part, other)	Full Flow
Capacity of c/case, less filter-refill-L (qt.)	3.8 (4.0)

Engine - Diesel Information

(NOT APPLICABLE)

Diesel engine manufacturer		
Glow plug, current drain at 0 deg. F		
Injector Nozzle	Type	
	Opening pressure kPa (psi)	
Pre-chamber design		
Fuel injection pump	Manufacturer	
	Type	
Fuel inj. pump drive (belt, chain, gear)		
Supplementary vacuum source (type)		
Fuel heater (yes/no)		
Water separator, description (std., opt.)		
Turbo manufacturer		
Oil cooler—type (oil to engine coolant; oil to ambient air)		
Oil filter		

Engine - Intake System

(NOT APPLICABLE)

Turbo charger - manufacturer	
Super charger - manufacturer	
Intercooler	

* Finished State

MVMA Specifications

Vehicle Line CAPRICE CLASSIC SEDAN
 Model Year '994 Issued 9-93 Revised _____

METRIC (U.S. Customary)

Engine Description	5.7 LITER V8 (350 CID)
Engine Code	SEQUENTIAL FUEL INJECTION RPO LT1

Engine - Valve System

Hydraulic lifters (std., opt., n.a.)	Standard	
Valves	Number intake/exhaust	8/8
	Head O.D. intake/exhaust	49.28 mm (1.94 in.) / 38.1 mm (1.50 in.)

Engine - Connecting Rods

Material & mass kg., (weight, lbs.)*	Steel
Length (axes centerline to centerline)	144.78 mm (5.70 in.)

Engine - Crankshaft

Material & mass kg., (weight, lbs.)*	Cast Iron	
End thrust taken by bearing (no.)	5	
Length & number of main bearings	5	
Seal (material, one, two piece design, etc.)	Front	Fluoroelastomer/One Piece Lip Seal
	Rear	Fluoroelastomer/One Piece Lip Seal

Engine - Lubrication System

Normal oil pressure kPa (psi) @ eng rpm	41 (6) @ 1000 / 124 (18) @ 2000 / 165 (24) @ 4000 Hot
Type oil intake (floating, stationary)	Stationary
Oil filter sys. (full flow, part, other)	Full Flow
Capacity of c/case, less filter-refill-L (qt.)	3.8 (4.0)

Engine - Diesel Information

(NOT APPLICABLE)

Diesel engine manufacturer		
Glow plug, current drain at 0 deg. F		
Injector Nozzle	Type	
	Opening pressure kPa (psi)	
Pre-chamber design		
Fuel injection pump	Manufacturer	
	Type	
Fuel inj. pump drive (belt, chain, gear)		
Supplementary vacuum source (type)		
Fuel heater (yes/no)		
Water separator, description (std., opt.)		
Turbo manufacturer		
Oil cooler-type (oil to engine coolant; oil to ambient air)		
Oil filter		

Engine - Intake System

(NOT APPLICABLE)

Turbo charger - manufacturer	
Super charger - manufacturer	
Intercooler	

* Finished State

MVMA Specifications

Vehicle Line CAPRICE CLASSIC POLICE SEDAN (SEO (9C1)
 Model Year 1994 Issued 9-93 Revised _____

METRIC (U.S. Customary)

Engine Description	5.7 LITER V8 (350 CID)
Engine Code	SEQUENTIAL FUEL INJECTION RPO LT1

Engine - Valve System

Hydraulic lifters (std., opt., n.a.)	Standard	
Valves	Number intake/exhaust	8/8
	Head O.D. intake/exhaust	49.28 mm (1.94 in.) / 38.1 mm (1.50 in.)

Engine - Connecting Rods

Material & mass kg., (weight, lbs.)*	Steel
Length (axes centerline to centerline)	144.78 mm (5.70 in.)

Engine - Crankshaft

Material & mass kg., (weight, lbs.)*	Cast Iron	
End thrust taken by bearing (no.)	5	
Length & number of main bearings	5	
Seal (material, one, two piece design, etc.)	Front	Fluoroelastomer/One Piece Lip Seal
	Rear	Fluoroelastomer/One Piece Lip Seal

Engine - Lubrication System

Normal oil pressure kPa (psi) @ eng rpm	41 (6) @ 1000 / 124 (18) @ 2000 / 165 (24) @ 4000 Hot
Type oil intake (floating, stationary)	Stationary
Oil filter sys. (full flow, part, other)	Full Flow
Capacity of oil case, less filter-refill-L (qt.)	3.8 (4.0)

Engine - Diesel Information (NOT APPLICABLE)

Diesel engine manufacturer		
Glow plug, current drain at 0 deg. F		
Injector Nozzle	Type	
	Opening pressure kPa (psi)	
Pre-chamber design		
Fuel injection pump	Manufacturer	
	Type	
Fuel inj. pump drive (belt, chain, gear)		
Supplementary vacuum source (type)		
Fuel heater (yes/no)		
Water separator, description (std., opt.)		
Turbo manufacturer		
Oil cooler-type (oil to engine coolant; oil to ambient air)		
Oil filter		

Engine - Intake System (NOT APPLICABLE)

Turbo charger - manufacturer	
Super charger - manufacturer	
Intercooler	

* Finished State

MVMA Specifications

Vehicle Line CAPRICE CLASSIC SEDAN
 Model Year 1994 Issued 3-93 Revised _____

METRIC (U.S. Customary)

Engine Description	4.3 LITER V8 (265 CID)
Engine Code	SEQUENTIAL FUEL INJECTION RPO L99

Engine - Cooling System

Coolant recovery system (std., opt., n.a.)		Pressurized Coolant System
Coolant fill location (rad., bottle)		Bottle, Coolant Recovery
Reservoir cap relief valve pressure (surge cap) kPa (psi)		Reservoir Cap: 103.4 (15.0)
Circulation thermostat	Type (choke, bypass)	Choke, Suction Side
	Starts to open @ deg's C(F)	82 (180)
Water Pump	Type (centrifugal, other)	Centrifugal
	GPM 1000 pump rpm	14
	Number of pumps	1
	Drive (V-belt, other)	Serpentine Belt
	Bearing type	Sealed Double Row Ball
	Impeller material	Steel
Housing material		Cast Aluminum
By-pass recirculation type (inter., ext.)		Internal
Cooling system capacity	With heater - L (qt.)	Not Applicable
	With air conditioner-L(qt.)	14.3 (15.1)
	Opt. equip. specify-L(qt.)	15.9 (16.8), Heavy Duty Cooling
Water jackets full length of cyl(yes,no)		Yes
Water all around cylinder (yes, no)		Yes
Water jackets open at head face (yes,no)		Yes
Radiator core	Std., A/C, HD	Standard
	Type (cross-flow, etc.)	Cross Flow
	Construction (fin & tube mechanical, braze, etc.)	Fin & Tube, Solder
	Matl., mass kg (wgt., lbs.)	Aluminum, Hi-Efficiency
	Width	762 mm (30.0 in.)
	Height	438 mm (17.2 in.)
	Thickness	34 mm (1.3 in.)
	Fins per inch	3.0
Radiator end tank material		Nylon
Fan	Std., elec., opt.	Standard, Electric
	Number of blades & type (flex, solid, material)	5 Blade, Polypropylene
	Number & location (front, rear of radiator)	2 Fans, Rearward Of Radiator
	Diameter & projected width	360 mm (14.2 in.)
	Ratio(fan to crnkshft.rev.)	Heavy Duty Clutch/Fan & 240 W. Electric
	Fan cutout type	ECM Control
	Drive type (direct, remote)	Electric Motor
	RPM at idle (elec.)	Pri. (150 W) 1900-2000 RPM; Sec. (100W) 1800-1900 RPM; HD 150W/240W
	Motor rating(wattage/elec.)	Pri. (150 W/12V) Right Side; Sec. (100 W/12V) Left Side; HD 150W/240W
	Motor switch (type & location/elec.)	Relay
	Switch point (temp./pressure/elec.)	Both Fans Electric On W/250 PSIG & Above On AC
	Fan shroud (material)	Polypropylene

MVMA Specifications

Vehicle Line CAPRICE CLASSIC SEDAN
 Model Year 1994 Issued 3-93 Revised _____

METRIC (U.S. Customary)

Engine Description 5.7 LITER V8 (350 CID)
 Engine Code SEQUENTIAL FUEL INJECTION RPO LT1

Engine - Cooling System

Coolant recovery system (std., opt., n.a.)	Pressurized Coolant System	
Coolant fill location (rad., bottle)	Bottle, Coolant Recovery	
Reservoir cap relief valve pressure (surge cap) kPa (psi)	Reservoir Cap: 103.4 (15.0)	
Circulation thermostat	Type (choke, bypass)	Choke, Suction Side
	Starts to open @ deg's C(F)	82 (180)
Water Pump	Type (centrifugal, other)	Centrifugal
	GPM 1000 pump rpm	14
	Number of pumps	1
	Drive (V-belt, other)	Serpentine Belt
	Bearing type	Sealed Double Row Ball
	Impeller material	Steel
Housing material	Cast Aluminum	
By-pass recirculation type (inter., ext.)	Internal	
Cooling system capacity	With heater - L (qt.)	Not Applicable
	With air conditioner - L (qt.)	14.3 (15.1)
	Opt. equip. specify - L (qt.)	15.9 (16.8), Heavy Duty Cooling
Water jackets full length of cyl (yes, no)	Yes	
Water all around cylinder (yes, no)	Yes	
Water jackets open at head face (yes, no)	Yes	
Radiator core	Std., A/C, HD	Standard
	Type (cross-flow, etc.)	Cross Flow
	Construction (fin & tube mechanical, brazes, etc.)	Fin & Tube, Solder
	Matl., mass kg (wgt., lbs.)	Aluminum, Hi-Efficiency
	Width	762 mm (30.0 in.)
	Height	438 mm (17.2 in.)
	Thickness	34 mm (1.3 in.)
Fins per inch	3.0	
Radiator end tank material	Nylon	
Fan	Std., elec., opt.	Standard, Electric
	Number of blades & type (flex, solid, material)	5 Blade, Polypropylene
	Number & location (front, rear of radiator)	2 Fans, Rearward Of Radiator
	Diameter & projected width	360 mm (14.2 in.)
	Ratio (fan to crnkshft, rev.)	Heavy Duty Clutch/Fan & 240 W. Electric
	Fan cutout type	ECM Control
	Drive type (direct, remote)	Electric Motor
	RPM at idle (elec.)	Pri. (150 W) 1900-2000 RPM; Sec. (100W) 1800-1900 RPM; HD 150W/240W
	Motor rating (wattage/elec.)	Pri. (150 W/12V) Right Side; Sec. (100 W/12V) Left Side; HD 150W/240W
	Motor switch (type & location/elec.)	Relay
Switch point (temp./pressure/elec.)	Both Fans Electric On W/250 PSIG & Above On AC	
Fan shroud (material)	Polypropylene	

MVMA Specifications

Vehicle Line CAPRICE CLASSIC POLICE SEDAN (SE0 9C1)
 Model Year 1994 issued 9-93 Revised

METRIC (U.S. Customary)

Engine Description
 Engine Code

5.7 LITER V8 (350 CID)
 SEQUENTIAL FUEL INJECTION RPO LT1

Engine - Cooling System

Coolant recovery system (std., opt., n.a.)		Pressurized Coolant System
Coolant fill location (rad., bottle)		Bottle, Coolant Recovery
Reservoir cap relief valve pressure (surge cap) kPa (psi)		Reservoir Cap: 103.4 (15.0)
Circulation thermostat	Type (choke, bypass)	Choke, Suction Side
	Starts to open @ deg's C(F)	82 (180)
Water Pump	Type (centrifugal, other)	Centrifugal
	GPM 1000 rpm	14
	Number of pumps	1
	Drive (V-belt, other)	Serpentine Belt
	Bearing type	Sealed Double Row Ball
	Impeller material	Steel
Housing material		Cast Aluminum
By-pass recirculation type (inter., ext.)		Internal
Cooling system capacity	With heater - L (qt.)	Not Applicable
	With air conditioner-L(qt.)	14.3 (15.1)
	Opt. equip. specify-L(qt.)	15.9 (16.8), Heavy Duty Cooling
Water jackets full length of cv(yes,no)		Yes
Water all around cylinder (yes, no)		Yes
Water jackets open at head face (yes,no)		Yes
Radiator core	Std., A/C, HD	Standard
	Type (cross-flow, etc.)	Cross Flow
	Construction (fin & tube mechanical, braze, etc.)	Fin & Tube, Solder
	Matl., mass kg (wgt., lbs.)	Aluminum, Hi-Efficiency
	Width	762 mm (30.0 in.)
	Height	438 mm (17.2 in.)
	Thickness	34 mm (1.3 in.)
Fins per inch		3.0
Radiator end tank material		Nylon
Fan	Std., elec., opt.	Standard, Electric
	Number of blades & type (flex, solid, material)	5 Blade, Polypropylene
	Number & location (front, rear of radiator)	2 Fans, Rearward Of Radiator
	Diameter & projected width	360 mm (14.2 in.)
	Ratio(fan to crnkshft.rev.)	Heavy Duty Clutch/Fan & 240 W. Electric
	Fan cutout type	ECM Control
	Drive type (direct, remote)	Electric Motor
	RPM at idle (elec.)	Pr. (150 W) 1900-2000 RPM; Sec. (100W) 1800-1900 RPM; HD 150W/240W
	Motor rating(wattage/elec.)	Pr. (150 W/12V) Right Side; Sec. (100 W/12V) Left Side; HD 150W/240W
	Motor switch (type & location/elec.)	Relay
	Switch point (temp.,/ pressure/elec.)	Both Fans Electric On W/250 PSIG & Above On AC
	Fan shroud (material)	

MVMA Specifications

Vehicle Line CAPRICE CLASSIC SEDAN

Model Year 1994 Issued 3-93 Revised _____

METRIC (U.S. Customary)

Engine Description

4.3 LITER V8 (265 CID)

Engine Code

SEQUENTIAL FUEL INJECTION RPO L99

Engine - Fuel System

(See supplemental page for details of Fuel Inj. Supercharger, Turbocharger, etc. if used)

Induction type: carburetor, fuel injection system, etc.		Sequential Port Fuel Injection
Manufacturer		AC Rochester Products
Carburetor no. of barrels		None
Idle A/F mix.		Preset - No Adjustment
Fuel Injection	Point of inj. (no.)	Fuel Injectors At Inlet Ports
	Constant, pulse, flow	Pulse
	Control (elec., mech.)	Electronic - On Board Computer
	Sys. press. kPa (psi)	300 (43.5)
Idle spd.-from (spec. neutral or drive and propane if used)	Manual	Not Applicable
	Automatic	PCM Controlled
Intake manifold heat control (exhaust or water thermostatic or fixed)		None
Air cleaner type		Replaceable Paper Element
Fuel filter (type/location)		409 Stainless Steel 12 / Attach To Frame, Right Side
Fuel pump	Type (elec. or mech.)	Electric
	Location (eng., tank)	Fuel Tank
	Press. range kPa (psi)	Normal 83.0 (12.0), Shut Off 135 (19.6)
	Flow rate at regulated pressure (L (gal)/hr @ kPa (psi))	23 - 30 gr/sec @ 83 (12.0)

Fuel Tank

Capacity refill L (gallons)		87 (23)
Location (describe)		Below Rear Compartment Pan
Attachment		Straps
Material & Mass kg (weight lbs.)		HDPE Mass - W/O Sender 11.1 kg.; W/Sender 12.7 kg.
Filler pipe	Location & material	Rear 1008-1010 Steel; Coating Lead/Tin
	Connection to tank	Clamped W/Hose Coupler
Fuel line (material)		Nylon Tubing 12
Fuel hose (material)		Rubber
Return line (material)		Nylon Tubing 12
Vapor line (material)		Nylon Tubing 12
Extended range tank	Opt., n.a.	Not Applicable
	Capacity L (gallons)	"
	Location & material	"
	Attachment	"
Auxiliary tank	Opt., n.a.	Not Applicable
	Capacity L (gallons)	"
	Location & material	"
	Attachment	"
	Slctr switch or valve	"
	Separate fill	"

MVMA Specifications

Vehicle Line CAPRICE CLASSIC SEDAN
 Model Year 1994 Issued 3-93 Revised _____

METRIC (U.S. Customary)

Engine Description 5.7 LITER V8 (350 CID)
 Engine Code SEQUENTIAL FUEL INJECTION RPO LT1

Engine - Fuel System (See supplemental page for details of Fuel Inj. Supercharger, Turbocharger, etc. if used)

Induction type: carburetor, fuel injection system, etc.		Sequential Port Fuel Injection
Manufacturer		AC Rochester Products
Carburetor no. of barrels		None
Idle A/F mix.		Preset - No Adjustment
Fuel Injection	Point of inj. (no.)	Fuel Injectors At Inlet Ports
	Constant. pulse, flow	Pulse
	Control (elec., mecn.)	Electronic - On Board Computer
	Sys. press. kPa (psi)	300 (43.5)
Idle spd.-rpm (spec. neutral or drive and propane if used)	Manual	Not Applicable
	Automatic	PCM Controlled
Intake manifold heat control (exhaust or water thermostatic or fixed)		None
Air cleaner type		Replaceable Paper Element
Fuel filter (type/location)		409 Stainless Steel 12 / Attach To Frame, Right Side
Fuel pump	Type (elec. or mech.)	Electric
	Location (eng., tank)	Fuel Tank
	Press. range kPa (psi)	Normal 83.0 (12.0), Shut Off 135 (19.6)
	Flow rate at regulated pressure (L (gal)/hr @ kPa (psi))	23 - 30 gr/sec @ 83 (12.0)

Fuel Tank

Capacity refill L (gallons)		87 (23)
Location (describe)		Below Rear Compartment Pan
Attachment		Straps
Material & Mass kg (weight lbs.)		HDPE Mass - W/O Sender 11.1 kg.; W/Sender 12.7 kg.
Filler pipe	Location & material	Rear 1008-1010 Steel: Coating Lead/Tin
	Connection to tank	Clamped W/Hose Coupler
Fuel line (material)		Nylon Tubing 12
Fuel hose (material)		Rubber
Return line (material)		Nylon Tubing 12
Vapor line (material)		Nylon Tubing 12
Extended range tank	Opt., n.a.	Not Applicable
	Capacity L (gallons)	"
	Location & material	"
	Attachment	"
Auxiliary tank	Opt., n.a.	Not Applicable
	Capacity L (gallons)	"
	Location & material	"
	Attachment	"
	Slctr switch or valve	"
	Separate fill	"

MVMA Specifications

Vehicle Line CAPRICE CLASSIC POLICE SEDAN (SE0 9C1)
 Model Year 1994 Issued 9-93 Revised _____

METRIC (U.S. Customary)

Engine Description	5.7 LITER V8 (350 CID)
Engine Code	SEQUENTIAL FUEL INJECTION RPO LT1

Engine - Fuel System (See supplemental page for details of Fuel Inj. Supercharger, Turbocharger, etc. if used)

Induction type: carburetor, fuel injection system, etc.		Sequential Port Fuel Injection
Manufacturer		AC Rochester Products
Carburetor no. of barrels		None
Idle A/F mix.		Preset - No Adjustment
Fuel Injection	Point of inj. (no.)	Fuel Injectors At Inlet Ports
	Constant. pulse. flow	Pulse
	Control (elec., mech.)	Electronic - On Board Computer
	Sys. press. kPa (psi)	300 (43.5)
Idle spd. -rpm (spec. neutral or drive and propane if used)	Manual	Not Applicable
	Automatic	PCM Controlled
Intake manifold heat control (exhaust or water thermostatic or fixed)		None
Air cleaner type		Replaceable Paper Element
Fuel filter (type/location)		409 Stainless Steel 12 / Attach To Frame, Right Side
Fuel pump	Type (elec. or mech.)	Electric
	Location (eng., tank)	Fuel Tank
	Press. range kPa (psi)	Normal 83.0 (12.0), Shut Off 135 (19.6)
	Flow rate at regulated pressure L (gal)/hr @ kPa (psi)	23 - 30 gr/sec @ 83 (12.0)

Fuel Tank

Capacity refill L (gallons)		87 (23)
Location (describe)		Below Rear Compartment Pan
Attachment		Straps
Material & Mass kg (weight lbs.)		HOPE Mass - W/O Sender 11.1 kg.; W/Sender 12.7 kg.
Filler pipe	Location & material	Rear 1008-1010 Steel: Coating Lead/Tin
	Connection to tank	Clamped W/Hose Coupler
Fuel line (material)		Nylon Tubing 12
Fuel hose (material)		Rubber
Return line (material)		Nylon Tubing 12
Vapor line (material)		Nylon Tubing 12
Extended range tank	Opt., n.a.	Not Applicable
	Capacity L (gallons)	"
	Location & material	"
	Attachment	"
Auxiliary tank	Opt., n.a.	Not Applicable
	Capacity L (gallons)	"
	Location & material	"
	Attachment	"
	Sictr switch or valve	"
	Separate fill	"

MVMA Specifications

Vehicle Line CAPRICE CLASSIC SEDAN
 Model Year 1994 Issued 9-93 Revised _____

METRIC (U.S. Customary)

Engine Description	4.3 LITER V8 (265 CID)
Engine Code	SEQUENTIAL FUEL INJECTION RPO L99

Vehicle Emission Control

Exhaust Emission Control	Type (air injection, engine modifications, other)		Air Injection W/Computer Command Control
	Air injection	Pump or pulse	Vane
		Driven by	Electric
		Air distribution (head, manifold, etc..)	Exhaust Manifold (Computer Command Control)
		Point of entry	Exhaust Manifold
	Exhaust Gas Recirculation	Type (controlled flow, open orifice, other)	Controlled Flow
		Exhaust source	
		Point of exh.inj. (spacer, carb., manifold, other)	Manifold
	Catalytic Converter	Type	3 Way
		Number of	2
Location(s)		LH - Close Coupled; RH - Underbody	
Volume L (cu.in)		1.54 (94.1), Each	
Substrate type		Monolith	
Noble metal type		Platinum (Pt), Rhodium (Rh)	
Noble metal concentration (g/cu. cm.)		.001755 Each	
Crankcase Emission Control	Type (ventilates to atmosphere, induction system, other)		Induction System
	Energy source (manifold vacuum, carburetor, other)		Manifold Vacuum
	Discharges to (intake manifold, other)		Intake Plenum
	Air int.(breather cap, other)		Air Cleaner
Evaporative Emission Control	Vapor vented to (crankcase, canister, other)	Fuel tank	Canister
		Carburetor	--
	Vapor storage provision		
Electronic System	Closed loop (yes/no)		Yes
	Open loop (yes/no)		No

Engine - Exhaust System

Type (single, single with cross-over, dual, other)		Single, With Cross-Over
Muffler no. & type (reverse flow, straight thru, separate resonator) Material & Mass kg (weight lbs.)		1, Reverse Flow
Resonator no. & type		1, Straight
Exhaust pipe	Branch o.d., wall thickness	*
	Main o.d., wall thickness	57.15 mm, 1.8 mm Min.
	Matl. & Mass kg (wght.lbs.)	Stainless Steel, 3.475 (7.66)
Intermediate pipe	o.d. & wall thickness	63.5 mm, 0.80 mm Min.
	Matl. & Mass kg (wght.lbs.)	Stainless Steel, 9.75 (21.5)
Tail pipe	o.d. & wall thickness	63.5 mm, 1.73 mm Min.
	Matl. & Mass kg (wght.lbs.)	Stainless Steel, 8.4 (18.5)

* 50.8 mm, Inner Tube SAE 1008 or 1010; 0.81 mm Min., Outer Tube Stainless Steel 0.86 mm Min.
 Inside and Outside Tubes Must Not Be Bonded Together.

MVMA Specifications

Vehicle Line CAPRICE CLASSIC SEDAN
 Model Year 1994 issued 9-93 Revised _____

METRIC (U.S. Customary)

Engine Description	5.7 LITER V8 (350 CID)
Engine Code	SEQUENTIAL FUEL INJECTION RPO LT1

Vehicle Emission Control

Exhaust Emission Control	Type (air injection, engine modifications, other)		Air Injection W/Computer Command Control
	Air injection	Pump or pulse	Vane
		Driven by	Electric
		Air distribution (head, manifold, etc.)	Exhaust Manifold
		Point of entry	Exhaust Manifold
	Exhaust Gas Recirculation	Type (controlled flow, open orifice, other)	Controlled Flow
		Exhaust source	
		Point of exh.in. (spacer, carb., manifold, other)	Manifold
	Catalytic Converter	Type	3 Way
		Number of	2
		Location(s)	LH - Close Coupled, RH - Underbody
		Volume L (cu.in.)	1.54 (94.1), Each
		Substrate type	Monolith
		Noble metal type	Platinum (Pt), Rhodium (Rh)
Noble metal concentration (g/cu. cm.)		.001755 Each	
Crankcase Emission Control	Type (ventilates to atmosphere, induction system, other)		Induction System
	Energy source (manifold vacuum, carburetor, other)		Manifold Vacuum
	Discharges to (intake manifold, other)		Intake Plenum
	Air inlet (breather cap, other)		Air Cleaner
Evaporative Emission Control	Vapor vented to (crankcase, canister, other)	Fuel tank	Canister
		Carburetor	--
	Vapor storage provision		Canister
Electronic System	Closed loop (yes/no)		Yes
	Open loop (yes/no)		No

Engine - Exhaust System

Type (single, single with cross-over, dual, other)		Dual
Muffler no. & type (reverse flow, straight thru, separate resonator) Material & Mass kg (weight lbs.)		2, Reverse Flow
Resonator no. & type		2, Straight
Exhaust pipe	Branch o.d., wall thickness	50.08 mm (1.97 in.)
	Main o.d., wall thickness	57.15 mm (2.25 in.); 1.8 mm (.070 in.), Min.
	Matl. & Mass kg (wght.lbs.)	Stainless Steel, 3.4 (7.5)
Inter-mediate pipe	o.d. & wall thickness	63.5 mm (2.5 in.); 1.40 mm (.055 in.), Min.
	Matl. & Mass kg (wght.lbs.)	Stainless Steel, 10.645 kg. (23.46 in.)
Tail pipe	o.d. & wall thickness	63.5 mm (2.5 in.); 1.73 mm (.068 in.), Min.
	Matl. & Mass kg (wght.lbs.)	Stainless Steel, 6.415 (14.1)

MVMA Specifications

Vehicle Line CAPRICE CLASSIC POLICE SEDAN (SEO 9C1)
 Model Year 1994 Issued 9-93 Revised _____

METRIC (U.S. Customary)

Engine Description
 Engine Code

5.7 LITER V8 (350 CID)
 SEQUENTIAL FUEL INJECTION RPO LT1

Vehicle Emission Control

Exhaust Emission Control	Type (air injection, engine modifications, other)		Air Injection W/Computer Command Control
	Air injection	Pump or pulse	Vane
		Driven by	Electric
		Air distribution (head, manifold, etc.,)	Exhaust Manifold
		Point of entry	Exhaust Manifold
	Exhaust Gas Recirculation	Type (controlled flow, open orifice, other)	Controlled Flow
		Exhaust source	
		Point of exh.inj. (spacer, carb., manifold, other)	Manifold
	Catalytic Converter	Type	3 Way
		Number of	2
		Location(s)	LH - Close Coupled, RH - Underbody
		Volume L (cu.in)	1.54 (94.1), Each
		Substrate type	Monolith
		Noble metal type	Platinum (Pt), Rhodium (Rh)
Noble metal concentration (g/cu. cm.)		.001755 Each	
Crankcase Emission Control	Type (ventilates to atmosphere, induction system, other)		Induction System
	Energy source (manifold vacuum, carburetor, other)		Manifold Vacuum
	Discharges to (intake manifold, other)		Intake Plenum
	Air inlet (breather cap, other)		Air Cleaner
Evaporative Emission Control	Vapor vented to (crankcase, canister, other)	Fuel tank	Canister
		Carburetor	--
	Vapor storage provision		Canister
Electronic System	Closed loop (yes/no)		Yes
	Open loop (yes/no)		No

Engine - Exhaust System

Type (single, single with cross-over, dual, other)		Dual
Muffler no. & type (reverse flow, straight thru, separate resonator) Material & Mass kg (weight lbs.)		2, Reverse Flow
Resonator no. & type		2, Straight
Exhaust pipe	Branch o.d., wall thickness	50.08 mm (1.97 in.)
	Main o.d., wall thickness	57.15 mm (2.25 in.); 1.8 mm (.070 in.), Min.
	Matl. & Mass kg (wght.lbs.)	Stainless Steel, 3.4 (7.5)
Inter-mediate pipe	o.d. & wall thickness	63.5 mm (2.5 in.); 1.40 mm (.055 in.), Min.
	Matl. & Mass kg (wght.lbs.)	Stainless Steel, 10.645 kg. (23.46 in.)
Tail pipe	o.d. & wall thickness	63.5 mm (2.5 in.); 1.73 mm (.068 in.), Min.
	Matl. & Mass kg (wght.lbs.)	Stainless Steel, 6.415 (14.1)

MVMA Specifications

Vehicle Line CAPRICE CLASSIC SEDAN
 Model Year 1994 Issued 9-93 Revised _____

METRIC (U.S. Customary)

Engine Description **4.3 LITER V8 (265 CID)**
 Engine Code **SEQUENTIAL FUEL INJECTION RPO L99**

Transmissions/Transaxle (Std., Opt., N.A.)

Manual 4-speed (manufacturer/country)	Not Available
Manual 5-speed (manufacturer/country)	"
Manual 6-speed (manufacturer/country)	"
Automatic (manufacturer/country)	"
Auto. overdrive (manufacturer/country)	Hydra-Matic, U.S.A. (M30)

Manual Transmission/Transaxle (NOT APPLICABLE)

Number of forward speeds		
Gear ratios	1st	
	2nd	
	3rd	
	4th	
	5th	
	6th	
	Reverse	
Synchronous meshing (specify gears)		
Shift lever location		
Trans. case mat'l. & mass kg (lbs)*		
Lubricant	Capacity L (qt.)	
	Type recommended	

Clutch (Manual Transmission) (NOT APPLICABLE)

Clutch manufacturer		
Clutch type (dry, wet; single, multiple disc)		
Linkage (hyd., cable, rod, lever, other)		
Max. pedal effort (nom. spring load) N (lbs.)	Depressed	
	Released	
Assist (spring, power/percent, nominal)		
Type pressure plate springs		
Total spring load (nominal) N (lbs)		
Clutch facing	Facing mfr. & mat'l. coding	
	Facing mat'l. & construction	
	Rivets per facing	
	Outside x inside dia. (nom.)	
	Total eff. area sq cm (sq in)	
	Thickness (pressure plate side/fly wheel side)	
	Rivet depth (pressure plate side/fly wheel side)	
Engagement cushion method		
Release bearing type & method lub.		
Torsional damping method, springs, hysteresis		

* Includes shift linkage, lubricant, and clutch housing. If other specify.

MVMA Specifications

Vehicle Line CAPRICE CLASSIC SEDAN
 Model Year 1994 Issued 9-93 Revised _____

METRIC (U.S. Customary)

Engine Description	5.7 LITER V8 (350 CID)
Engine Code	SEQUENTIAL FUEL INJECTION RPO LT1

Transmissions/Transaxle (Std., Opt., N.A.)

Manual 4-speed (manufacturer/country)	Not Available
Manual 5-speed (manufacturer/country)	"
Manual 6-speed (manufacturer/country)	"
Automatic (manufacturer/country)	"
Auto. overdrive (manufacturer/country)	Hydra-Matic, U.S.A. (M30)

Manual Transmission/Transaxle (NOT APPLICABLE)

Number of forward speeds		
Gear ratios	1st	
	2nd	
	3rd	
	4th	
	5th	
	6th	
	Reverse	
Synchronous meshing (specify gears)		
Shift lever location		
Trans. case mat'l. & mass kg (lbs)*		
Lubricant	Capacity L (pt.)	
	Type recommended	

Clutch (Manual Transmission) (NOT APPLICABLE)

Clutch manufacturer		
Clutch type (dry, wet; single, multiple disc)		
Linkage (hyd., cable, rod, lever, other)		
Max. pedal effort (nom. spring load) N (lbs.)	Depressed	
	Released	
Assist (spring, power/percent, nominal)		
Type pressure plate springs		
Total spring load (nominal) N (lbs)		
Clutch facing	Facing mfg. & mat'l. coding	
	Facing mat'l. & construction	
	Rivets per facing	
	Outside x inside dia. (nom.)	
	Total eff. area sq cm (sq in)	
	Thickness (pressure plate side/fly wheel side)	
	Rivet depth (pressure plate side/fly wheel side)	
Engagement cushion method		
Release bearing type & method lub.		
Torsional damping method, springs, hysteresis		

* Includes shift linkage, lubricant, and clutch housing. If other specify.

MVMA Specifications

Vehicle Line CAPRICE CLASSIC SEDAN

Model Year 1994 Issued 9-93 Revised _____

METRIC (U.S. Customary)

Engine Description

4.3 LITER V8 (265 CID)

Engine Code

SEQUENTIAL FUEL INJECTION RPO L99

Automatic Transmission/Transaxle

Trade Name		Hydra-Matic 4L60E
Type and special features (describe)		Electronic, 4-Speed Automatic, Overdrive 4th Gear Lock Up Torque Converter Clutch
Shift mechanics		
Gear selector	Location (column, floor, other)	Column
	Ltr./No. designation (e.g. PRND21)	P-R-N- D -D-2-1
	Shift interlock (yes, no, describe)	Yes
Gear ratios	1st	3.059
	2nd	1.625
	3rd	1.000
	4th	0.696
	5th	-
	6th	-
	Reverse	2.294
	Final drive ratio	2.73
Max. upshift vehicle speed - drive range km/h (mph)		1 - 2 = 80 (50) 2 - 3 = 148 (92)
Max. upshift engine speed RPM		5300 RPM
Max. kickdown speed - drive range km/h (mph)		3 - 2 = 116 (72) 2 - 1 = 51 (32)
Min. overdrive speed km/h (mph)		45 (28)
Torque converter	Type	3 Element With Converter Clutch
	Torus design	Full
	Number of elements	3
	Max. ratio at stall	1.91
	Type of cooling (air, liquid)	Liquid
	Nominal diameter	298 mm
	Capacity factor "K"	100
Pump type		Vane
Lubricant	Capacity refill L (pt.)	4.8 (10)
	Type recommended	Dexron IIE
Oil cooler (std., opt., N.A., internal, external, air, liquid)		External, Liquid
Trans. mass kg (lbs) & case matl.**		83 (184) Wet, Aluminum

All Wheel / 4 Wheel Drive

(NOT APPLICABLE)

Desc. & type (part-time, full-time, 2/4 shift while moving, mech., elect., chain/gear, etc.)

Transfer case	Manufacturer and model	
	Type and location	
Low-range gear ratio		
System disconnect (describe)		
Center differential	Type (bevel, planetary, w or w/o viscous bias, torsen, etc.)	
	Torque split(% frt/rear)	

* Input speed / square root of torque.

** Dry weight including torque converter. If other, specify.

MVMA Specifications

Vehicle Line CAPRICE CLASSIC SEDAN
 Model Year 1994 issued 3-93 Revised _____

METRIC (U.S. Customary)

Engine Description

5.7 LITER V8 (350 CID)

Engine Code

SEQUENTIAL FUEL INJECTION RPO LT1

Automatic Transmission/Transaxle

Trade Name		Hydra-Matic 4L60E
Type and special features (describe)		Electronic, 4-Speed Automatic, Overdrive 4th Gear Lock Up Torque Converter Clutch
Shift mechanics		
Gear selector	Location (column, floor, other)	Column
	Ltr./No. designation (e.g. PRND21)	P-R-N-D -D-2-1
	Shift interlock (yes, no, describe)	Yes
Gear ratios	1st	3.059
	2nd	1.625
	3rd	1.000
	4th	0.696
	5th	-
	6th	-
	Reverse	2.294
Final drive ratio		2.56
Max. upshift vehicle speed - drive range km/h (mph)		1 - 2 = 84 (52) 2 - 3 = 153 (95)
Max. upshift engine speed RPM		5150 RPM
Max. kickdown speed - drive range km/h (mph)		3 - 2 = 109 (68) 2 - 1 = 48 (30)
Min. overdrive speed km/h (mph)		45 (28)
Torque converter	Type	3 Element With Converter Clutch
	Torus design	Full
	Number of elements	3
	Max. ratio at stall	1.91
	Type of cooling (air, liquid)	Liquid
	Nominal diameter	298 mm
Capacity factor "K"		100
Pump type		Vane
Lubricant	Capacity refill L (pt.)	4.8 (10)
	Type recommended	Dexron IIE
Oil cooler (std., opt., N.A., internal, external, air, liquid)		External, Liquid
Trans. mass kg (lbs) & case matl.**		83 (184) Wet, Aluminum

All Wheel / 4 Wheel Drive

(NOT APPLICABLE)

Desc. & type (part-time, full-time, 2/4 shift while moving, mech., elect., chain/gear, etc.)		
Transfer case	Manufacturer and model	
	Type and location	
Low-range gear ratio		
System disconnect (describe)		
Center differential	Type (bevel, planetary, w or w/o viscous bias, torsen, etc.)	
	Torque split(% frt/rear)	

* Input speed / square root of torque.

** Dry weight including torque converter. If other, specify.

MVMA Specifications

Vehicle Line CAPRICE CLASSIC POLICE SEDAN (SED 9C1)
 Model Year 1994 Issued 9-93 Revised _____

METRIC (U.S. Customary)

Engine Description
 Engine Code

5.7 LITER V8 (350 CID)
 SEQUENTIAL FUEL INJECTION RPO LT1

Automatic Transmission/Transaxle

Trade Name		Hydra-Matic 4L60E
Type and special features (describe)		Electronic, 4-Speed Automatic, Overdrive 4th Gear Lock Up Torque Converter Clutch
Shift mechanics		
Gear selector	Location (column, floor, other)	Column
	Ltr./No. designation (e.g. PRND21)	P-R-N- D -D-2-1
	Shift interlock (yes, no, describe)	Yes
Gear ratios	1st	3.059
	2nd	1.625
	3rd	1.000
	4th	0.696
	5th	-
	6th	-
	Reverse	2.294
Final drive ratio		3.08
Max. upshift vehicle speed - drive range km/h (mph)		1 - 2 = 72 (45) 2 - 3 = 132 (82)
Max. upshift engine speed RPM		5300 RPM
Max. kickdown speed - drive range km/h (mph)		3 - 2 = 117 (73) 2 - 1 = 55 (34)
Min. overdrive speed km/h (mph)		47 (29)
Torque converter	Type	3 Element With Converter Clutch
	Torus design	Full
	Number of elements	3
	Max. ratio at stall	1.91
	Type of cooling (air, liquid)	Liquid
	Nominal diameter	298 mm
Capacity factor "K"		100
Pump type		Vane
Lubricant	Capacity refill L (pt.)	4.8 (10)
	Type recommended	Dexron IIE
Oil cooler (std., opt., N.A., internal, external, air, liquid)		External, Liquid
Trans. mass kg (lbs) & case matl.**		83 (184) Wet, Aluminum

All Wheel / 4 Wheel Drive

(NOT APPLICABLE)

Desc. & type (part-time, full-time, 2/4 shift while moving, mech., elect., chain/gear, etc.)		
Transfer case	Manufacturer and model	
	Type and location	
Low-range gear ratio		
System disconnect (describe)		
Center differential	Type (bevel, planetary, w or w/o viscous bias, torsen, etc.)	
	Torque split(% frt/rear)	

* Input speed / square root of torque.
 ** Dry weight including torque converter. If other, specify.

MVMA Specifications

Vehicle Line CAPRICE CLASSIC SEDAN
 Model Year 1994 Issued 3-93 Revised _____

METRIC (U.S. Customary)

Engine Description	4.3 LITER V8 (265 CID)
Engine Code	SEQUENTIAL FUEL INJECTION RPO L99

Axle Ratio and Tooth Combinations (See 'Power Teams' for axle ratio usage)

Axle ratio (or overall top gear ratio)		2.73 (1.91)	3.23 (2.26)
Ring gear o.d.		7.63	8.50
No. of teeth	Pinion	15	13
	Ring gear	41	42

Rear Axle Unit

Description		Semi-Floating Axle, Overhung Hypoid Drive Pinion and Ring Gear	
Limited slip differential (type)		Not Available	Cone Clutch
Drive pinion	Type	Hypoid Gear	
	Offset	38.1 (1.50)	44.0 (1.75)
No. of differential pinions		2	
Pinion/differential	Adjustment (shim, etc.)	Shim	
	Bearing adjustment	Collapsible Sleeve	
Driving wheel bearing (type)		Direct On Single Row Cylindrical	
Lubricant	Capacity L (pt.)	1.65 (3.5)	2.0 (4.2)
	Type recommended	GL-5 Gear Lubricant	

Propeller Shaft - Rear Wheel Drive

Manufacturer Type (straight tube, tube-in-tube, internal-external damper, etc.)		Straight Tube	
Outer diam. x length* x wall thickness	Manual 4-speed transmission	Not Applicable	
	Manual 5-speed transmission	"	
	Manual 6-speed transmission	"	
	Overdrive	"	
	Automatic transmission	76.2 x 1384 x 1.65 mm (3.00 x 54.49 x .065 in.) L99 & 4L60E & 8.5" Axle 76.2 x 1411 x 1.65 mm (3.00 x 55.55 x .065 in.) L99 & 4I60E & 7.625" Axle	
Inter-mediate bearing	Type (plain, anti-friction)	None	
	Lub. (fitting, prepack)	None	
Slip yoke	Type	Splined	
	Number of teeth	27	
	Spline o.d.	29.858 (1.175)	
Universal joints	Make and mfg. no.	Front	Saginaw Division, S-44
		Rear	Saginaw Division, S-44
	Number used	2	
	Type (ball and trunnion, cross)	Cross	
	Rr. attach(u-bolt, clamp, etc)	Strap & Bolt	
	Bearing	Type (plain, anti-friction)	Anti-Friction
Lubrication (fitting, prepack)		Pre-Packed	
Drive taken through (torque tube, arms or springs)		Control Arm	
Torque taken through (torque tube, arms or springs)		Control Arm	

* Centerline to centerline of universal joints, or to centerline of attachment.

MVMA Specifications

Vehicle Line CAPRICE CLASSIC SEDAN
 Model Year 1994 Issued 3-93 Revised _____

METRIC (U.S. Customary)

Engine Description	5.7 LITER V8 (350 CID)
Engine Code	SEQUENTIAL FUEL INJECTION RPO LT1

Axle Ratio and Tooth Combinations (See 'Power Teams' for axle ratio usage)

Axle ratio (or overall top gear ratio)		2.93 (2.05)
Ring gear o.d.		8.50
No. of teeth	Pinion	14
	Ring gear	41

Rear Axle Unit

Description		Semi-Floating Axle, Overhung Hypoid Drive Pinion And Ring Gear
Limited slip differential (type)		Cone Clutch (Limited Slip Required)
Drive pinion	Type	Hypoid Gear
	Offset	44.0 (1.75)
No. of differential pinions		2
Pinion/differential	Adjustment (shim, etc.)	Shim
	Bearing adjustment	Collapsible Sleeve
Driving wheel bearing (type)		Direct On Single Row Cylindrical
Lubricant	Capacity L (pt.)	2.0 (4.2)
	Type recommended	GL-5 Gear Lubricant

Propeller Shaft - Rear Wheel Drive

Manufacturer Type (straight tube, tube-in-tube, internal-external damper, etc.)		Straight Tube	
Outer diam. x length* x wall thickness	Manual 4-speed transmission	Not Applicable	
	Manual 5-speed transmission	"	
	Manual 6-speed transmission	"	
	Overdrive	"	
	Automatic transmission	76.2 x 1384 x 1.65 mm (3.00 x 54.49 x .065 in.) LT1 & 4L60E & 8.5" Axle	
Inter-mediate bearing	Type (plain, anti-friction)	None	
	Lub. (fitting, prepack)	None	
Slip yoke	Type	Splined	
	Number of teeth	27	
	Spline o.d.	29.858 mm (1.175 in.)	
Universal joints	Make and mfg. no.	Front	Saginaw Division, S-44
		Rear	Saginaw Division, S-44
	Number used	2	
	Type (ball and trunnion, cross)	Cross	
	Rr. attach (u-bolt, clamp, etc.)	Strap & Bolt	
	Bearing	Type (plain, anti-friction)	Anti-Friction
Lubrication (fitting, prepack)		Pre-Packed	
Drive taken through (torque tube, arms or springs)		Control Arm	
Torque taken through (torque tube, arms or springs)		Control Arm	

* Centerline to centerline of universal joints, or to centerline of attachment.

MVMA Specifications

Vehicle Line CAPRICE CLASSIC POLICE SEDAN (SEO 9C1)

Model Year '994 Issued 9-93 Revised _____

METRIC (U.S. Customary)

Engine Description

5.7 LITER V8 (350 CID)

Engine Code

SEQUENTIAL FUEL INJECTION RPO LT1

Axle Ratio and Tooth Combinations

(See 'Power Teams' for axle ratio usage)

Axle ratio (or overall top gear ratio)		3.08 (2.16)
Ring gear o.d.		8.50
No. of teeth	Pinion	13
	Ring gear	40

Rear Axle Unit

Description		Semi-Floating Axle, Overhung Hypoid Drive Pinion And Ring Gear
Limited slip differential (type)		Cone Clutch
Drive pinion	Type	Hypoid Gear
	Offset	44.0 (1.75)
No. of differential pinions		2
Pinion/differential	Adjustment (shim, etc.)	Shim
	Bearing adjustment	Collapsible Sleeve
Driving wheel bearing (type)		Direct On Single Row Cylindrical
Lubricant	Capacity L (pt.)	2.0 (4.2)
	Type recommended	GL-5 Gear Lubricant

Propeller Shaft - Rear Wheel Drive

Manufacturer Type (straight tube, tube-in-tube, internal-external damper, etc.)		Straight Tube	
Outer diam. x length* x wall thickness	Manual 4-speed transmission	Not Applicable	
	Manual 5-speed transmission	"	
	Manual 6-speed transmission	"	
	Overdrive	"	
	Automatic transmission	76.2 x 1384 x 1.65 mm (3.00 x 54.49 x .065 in.) LT1 & 4L60E & 8.5" Axle	
Inter-mediate bearing	Type (plain, anti-friction)	None	
	Lub. (fitting, prepack)	None	
Slip yoke	Type	Splined	
	Number of teeth	27	
	Spline o.d.	29.858 mm (1.175 in.)	
Universal joints	Make and mfg. no.	Front	Saginaw Division, S-44
		Rear	Saginaw Division, S-44
	Number used	2	
	Type (ball and trunnion, cross)	Cross	
	Rr. attach (u-bolt, clamp, etc)	Strap & Bolt	
Bearing	Type (plain, anti-friction)	Anti-Friction	
	Lubrication (fitting, prepack)	Pre-Packed	
Drive taken through (torque tube, arms or springs)		Control Arm	
Torque taken through (torque tube, arms or springs)		Control Arm	

* Centerline to centerline of universal joints, or to centerline of attachment.

MVMA Specifications

Vehicle Line CAPRICE CLASSIC SEDAN
 Model Year 1994 Issued 1-93 Revised(*) _____

METRIC (U.S. Customary)

Model Code/Description And/Or
 Engine Code/Description

ALL

Suspension - General Including Electronic Controls

Car leveling	Std./opt./not avail.	Not Applicable	
	Manual/automatic control	"	
	Type (air/hydraulic)	"	
	Primary/assist spring	"	
	Rear only/4 wheel leveling	"	
	Single/dual rate spring	"	
	Single/dual ride heights	"	
	Provision for jacking	"	
Shock absorber damping controls	Standard/option/not avail.	Not Applicable	
	Manual/automatic control	"	
	Number of damping rates	"	
	Type of actuation (manual/electric motor/air, etc.)	"	
	s e n s o r s	Lateral acceleration	"
		Deceleration	"
		Acceleration	"
Road surface		"	
Shock absorber (front & rear)	Type	Sed. Base 25mm Tw.Tube Gas Chrgd./FE2 & 783 Sed. 32mm Tw.Tube PLIA Cell. LS	
	Make	Delco Chassis Division	
	Piston diameter	Base 25mm (1 in.) / FE2 32mm (1.26 in.), LS	
	Rod diameter	Base 12.7mm (0.5 in.) / FE2 12.7mm (0.5 in.), LS	

Suspension - Front

Type and description		SLA
Travel	Full jounce (define load condition)	90 mm (3.4 in.) @ Design (3-Passenger)
	Full rebound	108mm (4.3 in.) @ Design (3 Passenger)
Spring	Type (coil, leaf, other & matl)	Coil (Steel/Warm Set, Painted)
	Insulators (type & matl)	Front Upper (Natural Rubber)
	Size (Leaf: length & width; Coil: design height & i.d.; Bar: length & diameter)	Checking Height 296.8mm (11.7 in.) Coil: I.D. 102.9mm (4.05 in.)
	Spring rate N/mm (lb./in.)	Base Sedan 53 (303) FE2 Sedan 77 (440), LS
	Rate @ wheel N/mm (lb./in)	Base Sedan 27 (154) FE2 Sedan 39 (223), LS
Stabilizer	Type (link, linkless, frmless)	Link
	Material & O.D. bar/tube, wall thickness	Solid Steel, 26.0 mm (1.02 in.) Base; 30.0 mm (1.18 in.) Uplevel

Suspension - Rear

Type and description		4-Link, Solid Axle	
Travel	Full jounce (define load condition)	110mm (4.3 in.) @ Design (3-Passenger)	
	Full rebound	129mm (5.1 in.) @ Design (3 Passenger)	
Spring	Type (coil, leaf, other & matl)	Coil (Steel, Warm Set, Paint)	
	Size (Leaf: length & width; Coil: design height & i.d.; Bar: length & diameter)	Checking Height, 302.7 mm (11.9 in.) Coil: I.D., 140.0 mm (5.5 in.)	
	Spring rate N/mm (lb/in)	Base Sedan 18 (103)/FE2/7B3 Sedan 27 (154), LS	
	Rate @ wheel N/mm (lb/in)	Base Sedan 17.8 (101)/FE2/7B3 Sedan 26.6 (152), LS	
	Insulators (type & material)	Upper (Butyl)	
	If leaf	No. of leaves	Not Applicable
		Shackle (comp or tens)	"
Stabilizer	Type (link, linkless, frmless)	Base: None; FE2/FE3: Uplevel (LS)	
	Material & O.D. bar/tube, wall thickness	Solid Steel; 24.0 mm (0.94 in.), FE2 - 26.0 mm (1.02 in.), FE3	
Track bar (type)		Not Applicable	

MVMA Specifications

METRIC (U.S. Customary)

Vehicle Line CAPRICE CLASSIC SEDAN
 Model Year 1994 Issued 3-93 Revised(*)

Model Code/Description And/Or
 Engine Code/Description
 Brakes - Service

ALL

Description		Single Caliper Disc Front Duo-Servo Drum Rear	
Manufacturer and brake type (std., opt., n.a.)	Front (disc or drum)	Delco Chassis Division. Standard Disc	
	Rear (disc or drum)	Delco Chassis Division. Standard Drum	
Valving type (prog. delay, metering, other)		Combination, Metering And Proportioning	
Power brake (std., opt., n.a.)		Standard	
Booster type (rmt, integri, vac., hyd., etc.)		Vacuum	
Vacuum	Source (inline, pump, etc.)	Engine Manifold	
	Reservoir (volume cu. in.)	Not Applicable	
	Pump-type	"	
Traction assist	Operational speed range	Not Applicable	
	Type (engine or brake intervention)	"	
Antilock device	Front/rear (std., opt., n.a.)	Standard	
	Manufacturer	Robert Bosch Corporation	
	Type (electronic, mech.)	Electronic	
	Number sensors or circuits	3	
	No. antilock hyd. circuits	3	
	Integral or add-on system	Add-On	
Yaw control (yes, no)		Yes	
Hydraulic power source		Electrical	
Effective area sq. cm. (sq. in.)*		740 (114.7)	
Gross Lng area sq cm (sq in)** (F/R)		270.2 (41.9)/521.5 (80.8)	
Swept area sq cm (sq in)** (F/R)		1563.3 (242.3)/763.5 (118.34), Sedan; 1563.3 (242.3)/883.9 (137.0), Police	
Rotor	Outer working diameter	F 305mm (12 in.)	
	Inner working diameter	F 208mm (8.19 in.)	
	Thickness	F 25.4mm (1 in.)	
	Matl & type (vented/sld)	F Cast Iron Vented	
Drum	Diameter & width	R 241mm (9.5 in.)/51mm (2 in.), Sedan; 279mm (11 in.)/51mm (2 in.), Police	
	Type and material	R Cast Iron Fined	
Wheel cylinder bore		25.4mm (1.0 in.) Police; 22.2 mm (0.87 in.) Caprice Classic Sedan	
Master cylinder	Bore/stroke	28.6mm Bore/37.06mm Stroke (Worst Case)	
Pedal ratio		3.5:1	
Line pressure at 445 N (100 lb.) pedal load kPa (psi)		8614 kPa (1250 psi)	
Lining clearance		F/R 0mm (0 in.)/.75mm (.030 in.)	
Brake lining	Front wheel	Bonded or riveted	Riveted (8)
		Rivet size	Head: 9.1mm (.359 in.)/Shank: 5.3mm (.21 in.)
		Manufacturer	Delco Chassis Division
		Lining code ****	
		Material	DM8120, Sedan; Bendix 7161A, Police
		**** Pri. or out-brd	66.87 cu. cm (4.08 cu. in.)
		Size Sec. or in-brd	66.87 cu. cm (4.08 cu. in.)
		Shoe thckns. (no lng)	3.2mm (.125 in.) Outboard/5.1mm (.200 in.) Inboard
	Rear wheel	Bonded or riveted	Riveted
		Manufacturer	Delco Chassis Division
		Lining code ****	
		Material	DM 4064, Sedan; DM 4035/4050, Police
		**** Pri. or out-brd	59.65 cu. cm. (3.64 cu. in.), Sedan; 77.08 cu. cm. (4.80 cu. in.), Police
		Size Sec. or in-brd	98.92 cu. cm. (6.05 cu. in.), Sedan; 114.47 cu. cm. (7.11 cu. in.), Police
Shoe thckns. (no lng)		1.80 - 2.16mm (.071 - .085 in.)	

* Excludes rivet holes, grooves, chamfers, etc. **Includes rivet holes, grooves, chamfers, etc.
 *** Total swept area for four brakes. (Drum brake: Widest lining contact width for each brake x its contact circum.)
 (Disc brake: Square of Outer Working Dia. - Square of inner Working Dia. multiplied by Pi/2 for each brake.)
 **** Size for drum brakes includes length x width x thickness.
 ***** Manufacturer I.D., catalog for formulation designation and coefficient of friction classification.

MVMA Specifications

Vehicle Line CAPRICE CLASSIC SEDAN
 Model Year 1994 Issued 3-93 Revised _____

METRIC (U.S. Customary)

Model Code/Description And/Or
 Engine Code/Description

ALL

Tires And Wheels (Standard)

Tires	Size (service description)		P215/75R15 B/W - Base
	Type (bias, radial, etc.)		Radial
	Inflation pressure (cold) for recommended max. vehicle load	Front kPa (psi)	207 (30)
		Rear kPa (psi)	207 (30)
Rev/mile-at 70 km/h(45mph)		468 km / 753 mph	
Wheels	Type & material		Stamped Steel
	Rim (size & flange type)		15 x 7 'J'
	Wheel offset		7.6 mm
	Attachment	Type (bolt or stud & nut)	Stud & Nut
		Circle diameter	5"
Number & size		5 x 12 mm	
Spare	Tire and wheel		T145/80D16 16 x 4
	Storage position & location (describe)		Rearward In Trunk - Under Shelf Panel

Tires And Wheels (Optional)

Tire size (service description)		P215/75R15 W/S
Type (bias, radial, steel, nylon, etc.)		Radial
Wheel (type & material)		Stamped Steel
Rim (size, flange type and offset)		15 x 7 'J'
Tire size (service description)		P225/70R15 W/S - Caprice Classic LS
Type (bias, radial, steel, nylon, etc.)		Radial
Wheel (type & material)		Cast Aluminum
Rim (size, flange type and offset)		15 x 7 'JJ' x 8.0 mm
Tire size (service description)		
Type (bias, radial, steel, nylon, etc.)		
Wheel (type & material)		
Rim (size, flange type and offset)		
Tire size (service description)		
Type (bias, radial, steel, nylon, etc.)		
Wheel (type & material)		
Rim (size, flange type and offset)		
Spare tire and wheel size		
(if configuration is different than road tire or wheel, describe optional spare tire and/or wheel location & storage position)		

Brakes - Parking

Type of control		Pedal
Location of control		Dash Panel
Operates on		Cable
If separate from service brakes	Type (internal or external)	Internal
	Drum diameter	279 mm (11.0 in.) Includes Police
	Lining size (length x width x thickness)	Primary 59.65 cu. cm. Secondary 98.92 cu. cm. - Caprice Classic Primary 77.08 cu. cm. Secondary 114.47 cu. cm. - Police

MVMA Specifications

Vehicle Line CAPRICE CLASSIC SEDAN
 Model Year 1994 Issued 9-93 Revised(*) _____

METRIC (U.S. Customary)

Model Code/Description And/Or
 Engine Code/Description

ALL

Steering

Manual (std., opt., n.a.)		Not Applicable		
Power (std., opt., n.a.)		Standard		
Speed-sensitive (std., opt., n.a.)		Not Applicable		
4-wheel steering (std., opt., n.a.)		Not Applicable		
Adjustable steering wheel/column (tilt, telescope, other)	Type	Tilt		
	Manufacturer	Saginaw Division		
	(std., opt., n.a.)	Standard		
Wheel diameter ** (W9) SAE J1100	Manual	Not Applicable		
	Power	387mm O.D.		
Turning diameter m (ft.)	Out-side front	Wall to wall (l. & r.)	40'6" - 42'5"	
		Curb to curb (l. & r.)	37'8" - 39'9"	
	In-side rear	Wall to wall (l. & r.)	20'7" - 22'6"	
		Curb to curb (l. & r.)	21'1" - 23'2"	
Scrub Radius *		78.0 mm - P215		
Manual	Gear	Type	Not Applicable	
		Manufacturer	"	
	Ratios	Gear	"	
		Overall	"	
	No. wheel turns(stop to stop)		"	
Power	Type (coaxial,elec,hyd.,etc.)		Hydraulic	
	Manufacturer		Saginaw Division	
	Gear	Type	Integral	
		Ratios	Gear	Base, Police, 14:1; FE2, 12.7:1
			Overall	16.07, 15.3 (Police)
	Pump (drive)		Belt	
No. wheel turns(stop to stop)		3.17, 3.06 (Police)		
Linkage	Type		Parallelogram W/Lube Fittings	
	Location (front or rear of wheels, other)		Front	
	Tie Rods (one or two)		See Linkage	
Steering axis	Inclination at camber (deg.)		0 +/- .8	
	Bear-ings (type)	Upper	Not Applicable	
		Lower	"	
		Thrust	"	
Steering spindle/knuckle & joint type		Tapered Stud		

* The horizontal distance in the front elevation between wheel centerline and kingpin (ball joint) axis at ground.
 ** See Page 22.

MVMA Specifications

METRIC (U.S. Customary)

Vehicle Line CAPRICE CLASSIC SEDAN
 Model Year 1994 Issued 9-93 Revised(*)

Model Code/Description And/Or
 Engine Code/Description

ALL

Wheel Allinment

Front wheel at curb mass (wt.)	Service checking	Caster (deg.)	3.5 (+/-) 1.0
		Camber (deg.)	0.0 (+/-) 0.8
		Toe-in outside track - mm (in.)	0.16 (+/-) 0.20
	Service reset*	Caster (deg.)	2.8 (+/-) 3.5
		Camber (deg.)	0.8 (+/-) 0.8
		Toe-in - mm(in.)	0.16 (+/-) 0.16
	Periodic M.V. in-spection	Caster (deg.)	2.8 (+/-) 1.0
		Camber (deg.)	0.0 (+/-) 0.8
		Toe-in - mm(in.)	0.16 (+/-) 0.20
Rear wheel at curb mass (wt.)	Service checking	Camber (deg.)	Not Applicable
		Toe-in outside track - mm (in.)	"
	Service reset*	Camber (deg.)	"
		Toe-in - mm(in.)	"
	Periodic M.V. in-spection	Camber (deg.)	"
		Toe-in - mm(in.)	"

* Indicates pre-set, adjustable, trend set or other.

Electrical - Instruments and Equipment

Speedometer	Type (analog, digital, std., opt.)	Digital Standard
	Trip odometer (std., opt., n.a.)	Standard
Head-up display	Std., opt., not avail.	Not Applicable
	Type - Secondary, Opto-electronic	"
	Speedometer	Digital
	Status/warn. indicators - Turn signals, high beam, low fuel, check gauges	"
	Brightness control	Day/night mode, ad.
EGR maintenance indicator		None
Charge indicator	Type	Gage
	Warning device (light, audible)	Light
Temperature indicator	Type	Gage
	Warning device	Light
Oil pressure indicator	Type	Telltale
	Warning device	Light
Fuel indicator	Type	Gage
	Warning device	N.A.
Windshield wiper	Type (standard)	Delay
	Type (optional)	None
	Blade length	22 in.
	Sweep area sq cm (sq in)	7655.8 (1186.9)
Windshield washer	Type (standard)	Centrifugal Pump - Demand Wash
	Type (optional)	Not Applicable
	Fluid level indicator	Light (Classic LS)
Rear window wiper, wiper/washer (std., opt., n.a.)		Not Applicable
Horn	Type	Delco
	Number used	2
Other		Low Coolant Indicator, Telltale-Light (Classic LS) Low Oil Level Indicator, Telltale-Light (All Sedans) Change Oil Monitor, Telltale (All Sedans) Airbag - Telltale - Light

MVMA Specifications

Vehicle Line CAPRICE CLASSIC SEDAN
 Model Year 1994 Issued 9-93 Revised _____

METRIC (U.S. Customary)

Engine Code/Description 4.3 LITER V8 (265 CID)
SEQUENTIAL FUEL INJECTION RPO L99

Electrical - Supply System

Battery	Manufacturer	Delco Remy
	Model, std., (opt.)	Standard
	Voltage	12 V
	Amps at 0 deg F cold crnk	525
	Minutes-reserve capacity	90 Min. Reserve
	Amps/hrs. - 20 hr. rate	54 Amps/hrs.
	Location	Engine Compartment, Right Front
Alternator	Manufacturer	Delco Remy
	Rating (idle/max. rpm)	36/100 (1600/6500 Generator RPM)
	Ratio (alt. crank/rev.)	3.0
	Output at idle (rpm, park)	36 Amps
	Optional (type & rating)	--
Regulator	Type	Temperature Compensated Per Curve "C" - 6507

Electrical - Starting System

Motor	Manufacturer	Nippon Denso
	Current drain 0 deg C (F)	350 Amps
	Power rating kw (hp)	1.6 (2.1)
Motor drive	Engagement type	Positive Shift Solenoid
	Pinion engages from (front, rear)	Rear

Electrical - Ignition System

Type	Electronic (std, opt, n.a.)	--	
	Other (specify)	Opti-Spark Ignition System	
Coil	Manufacturer	Delco Remy	
	Model		
	Current	Engine stopped - A	--
		Engine idling - A	--
Spark plug	Manufacturer	AC Rochester	
	Model	R45LTSP	
	Thread (mm)	M14 x 1.25	
	Tightening torque Newton meters (lb. ft.)	24-30 (18-22)	
	Gap	1.27 (0.050 in.)	
	Number per cylinder	1	
Distributor	Manufacturer	Delco Remy	
	Model	1103878	

Electrical - Suppression

Locations & type	Internal Generator Capacitor, Non-Metallic High-Tension Cables, Resistor Spark Plugs, Ignition Coil By-Pass Capacitor, Internal AC Blower Motor By-Pass Capacitor & A/C Compression Diode, With Radio Provisions; Fuse Block Capacitor And On "Heater Only" Blower Motors And Coax Capacitor.
------------------	---

MVMA Specifications

Vehicle Line CAPRICE CLASSIC SEDAN
 Model Year 1994 Issued 9-93 Revised _____

METRIC (U.S. Customary)

Engine Code/Description

5.7 LITER V8 (350 CID)
 SEQUENTIAL FUEL INJECTION RPO LT1

Electrical - Supply System

Battery	Manufacturer	Delco Remy
	Model, std., (opt.)	Standard
	Voltage	12 V
	Amps at 0 deg F cold crnk	525
	Minutes-reserve capacity	90 Min. Reserve
	Amps/hrs. - 20 hr. rate	54 Amps/hrs.
	Location	Engine Compartment, Right Front
Alternator	Manufacturer	Delco Remy
	Rating (idle/max. rpm)	36/100 (1800/6500 Generator RPM)
	Ratio (alt. crank/rev.)	3.0
	Output at idle (rpm, park)	36 Amps
	Optional (type & rating)	--
Regulator	Type	Temperature Compensated Per Curve "C" - 6507

Electrical - Starting System

Motor	Manufacturer	Nippon Denso
	Current drain 0 deg C (F)	350 Amps
	Power rating kw (hp)	1.6 (2.1)
Motor drive	Engagement type	Positive Shift Solenoid
	Pinion engages from (front, rear)	Rear

Electrical - Ignition System

Type	Electronic (std, opt, n.a.)	--
	Other (specify)	Opti-Spark Ignition System
Coil	Manufacturer	Delco Remy
	Model	
	Current	Engine stopped - A -- Engine idling - A --
Spark plug	Manufacturer	AC Rochester
	Model	R45LTSP
	Thread (mm)	M14 x 1.25
	Tightening torque Newton meters (lb. ft.)	24-30 (18-22)
	Gap	1.27 (0.050 in.)
Distributor	Number per cylinder	1
	Manufacturer	Delco Remy
	Model	1103878

Electrical - Suppression

Locations & type	Internal Generator Capacitor, Non-Metallic High-Tension Cables, Resistor Spark Plugs, Ignition Coil By-Pass Capacitor, Internal AC Blower Motor By-Pass Capacitor & A/C Compression Diode, With Radio Provisions; Fuse Block Capacitor And On"Heater Only" Blower Motors And Coax Capacitor.
------------------	--

MVMA Specifications

Vehicle Line CAPRICE CLASSIC POLICE SEDAN (SEO 9C1)
 Model Year '894 Issued 9-93 Revised _____

METRIC (U.S. Customary)

Engine Code/Description 5.7 LITER V8 (350 CID)
SEQUENTIAL FUEL INJECTION RPO LT1

Electrical - Supply System

Battery	Manufacturer	Delco Remy
	Model, std., (opt.)	Standard
	Voltage	12 V
	Amps at 0 deg F cold crnk	525
	Minutes-reserve capacity	90 Min. Reserve
	Amps/hrs. - 20 hr. rate	54 Amps/hrs.
	Location	Engine Compartment, Right Front
Alternator	Manufacturer	Delco Remy
	Rating (idle/max. rpm)	36/100 (1600/6500 Generator RPM)
	Ratio (alt. crank/rev.)	3.0
	Output at idle (rom. park)	36 Amps
	Optional (type & rating)	--
Regulator	Type	Temperature Compensated Per Curve "C" - 6507

Electrical - Starting System

Motor	Manufacturer	Nippon Denso
	Current drain 0 deg C (F)	350 Amps
	Power rating kw (hp)	1.6 (2.1)
Motor drive	Engagement type	Positive Shift Solenoid
	Pinion engages from (front, rear)	Rear

Electrical - Ignition System

Type	Electronic (std, opt, n.a.)	--	
	Other (specify)	Opti-Spark Ignition System	
Coil	Manufacturer	Delco Remy	
	Model		
	Current	Engine stopped-A	--
		Engine idling - A	--
Spark plug	Manufacturer	AC Rochester	
	Model	R45LTSP	
	Thread (mm)	M14 x 1.25	
	Tightening torque Newton meters (lb. ft.)	24-30 (18-22)	
	Gap	1.27 (0.050 in.)	
	Number per cylinder	1	
Distributor	Manufacturer	Delco Remy	
	Model	1103878	

Electrical - Suppression

Locations & type	Internal Generator Capacitor, Non-Metallic High-Tension Cables, Resistor Spark Plugs, Ignition Coil By-Pass Capacitor, Internal AC Blower Motor By-Pass Capacitor & A/C Compression Diode, With Radio Provisions; Fuse Block Capacitor And On"Heater Only" Blower Motors And Coax Capacitor.
------------------	--

MVMA Specifications

Vehicle Line CAPRICE CLASSIC SEDAN
 Model Year 1994 Issued 3-93 Revised(*) _____

METRIC (U.S. Customary)

Model Code/Description ALL

Body

Structure	All Welded Heavy-Gage Steel Body. Full Perimeter Frame.	
Bumper system front - rear	Frame Mounted Steel Beam On Delco Energy Absorbers Covered With Urethane Fascia. Performance 5 mph.	
Anti-corrosion treatment	2-Sided Galvanized A-METAL REQUIREMENTS 1. Quarter 2. Door Inner & Outer 3. Fender Inner & Outer 4. Hood Inner & Outer 5. Decklid Inner & Outer	B-SUBSEQUENT COATINGS 1. Phosphate 2. Cathodic Epoxy 3. Augmented Waxes

Body - Miscellaneous Information

Type of finish (lacquer, enamel, other)	Base-Coat/Clear-Coat	
Hood	Material & mass	Steel. Hood Assembly With Grille, Brks, Insulator (26.5)
	Hinge location (front, rear)	Rear
	Type (counterbalance, prop)	Gas Spring
	Release control (int., ext.)	Internal
Trunk lid	Material & mass	Steel. (19.6)
	Type (counterbalance, other)	Torque Rod
	Internal release control (elec., mech., n.a.)	Optional, Electric
Hatch-back lid	Material & mass	Not Applicable
	Type (counterbalance, other)	"
	Internal release control (elec., mech., n.a.)	"
Tailgate	Material & mass	"
	Type (drop, lift, door)	"
	Internal release control (elec., mech., n.a.)	"
Vent window control (crank, friction, pivot, power)	Front	"
	Rear	"
Window regulator type (cable, tape, flex drive, etc.)	Front	Cross-Arm Regulator
	Rear	Cross-Arm Regulator
Seat cushion type (e.g., 60/40, bucket, bench wire, foam, etc.)	Front	Bench Std., Wire Susp.: 55 Driver, 45 Pass., Wire Susp. Avail.
	Rear	Bench Std., Wire/Foam Suspension
	3rd seat	Not Applicable
Seat back type (e.g., 60/40, bucket, bench, wire, foam, etc.)	Front	Bench Std., Wire Susp.: 55 Driver, 45 Pass., Wire Susp., Armrest
	Rear	Bench Std., Wire/Foam Susp.: Armrest Version Available
	3rd seat	Not Applicable

Frame

Type and description (separate frame, unitized frame, partially-unitized frame)	Separate Frame. Sedan: 2 Crossmembers
---	---------------------------------------

MVMA Specifications

Vehicle Line CAPRICE CLASSIC SEDAN
 Model Year 1994 Issued 9-93 Revised(*) _____

METRIC (U.S. Customary)

Model Code/Description

ALL

Restraint System

Seating Position			Left	Center	Right
Active	Type & description (lap & shoulder belt, lap belt, etc.)	First seat	Lap And Shoulder Belt	Lap Belt	Lap And Shoulder Belt
		Second seat	Lap And Shoulder Belt	Lap Belt	Lap And Shoulder Belt
	Standard/optional	Third seat	Not Applicable	Not Applicable	Not Applicable
Passive	Type & description (air bag, motorized-2-point belt, fixed belt, knee bolster, manual-lap belt)	First seat	Supplemental Inflatable Restraint	Not Applicable	Supplemental Inflatable Restraint
		Second seat	Not Applicable	Not Applicable	Not Applicable
	Standard/optional	Third seat	Not Applicable	Not Applicable	Not Applicable

Glass

	SAE Ref No	
Windshield glass exposed surface area sq. cm. (sq. in.)	S1	7276.8 (1127.9)
Side glass exposed surface area sq. cm. (sq. in.) - total 2-sides	S2	18124.5 (2809.3)
Backlight glass exposed surface area sq. cm. (sq. in.)	S3	5919.4 (917.5)
Total glass exposed surface area sq. cm. (sq. in.)	S4	31320.7 (4854.7)
Windshield glass (type/thickness)		Curved - Laminated Plate, 5.5 mm
Side glass (type/thickness)		Curved - Tempered Plate, 4.0 mm
Backlight glass (type/thickness)		Curved - Tempered Plate, 5.5 mm
Tinted (yes/no, location)		Yes, Windshield
Solar control (yes/no, coated/batched, location)		No

Headlamps

Description - sealed beam, halogen, replaceable bulb, etc.	Replacement Bulb
Shape	Contoured
Lo-beam type (2A1, 2B1, 2C1, etc.)	9004 Bulb
Quantity	2 Per Vehicle
Hi-beam type (1A1, 2A1, 1C1, 2C1, etc.)	Included In Lo-Beam Bulb 9004
Quantity	Not Applicable

MVMA Specifications

Vehicle Line CAPRICE CLASSIC SEDAN

Model Year 1994 Issued 8-93 Revised

METRIC (U.S. Customary)

Engine Code/Description

STATION WAGON

Climate Control System

Air conditioning (std., opt., man., auto.)		Standard, Automatic
Condenser	Type	Tube & Fin. Std.: HTC, Opt.
	Eff. face area (sq. mm.)	307,300. Std.: HTC, Opt.
	Fins per inch	13. Std.: HTC, Opt.
Evaporator	Type	Plate/Center
	Eff. face area (sq. mm.)	61,200
	Fins per inch	14
Heater Core	Material	Aluminum
	Eff. face area (sq. mm.)	32,660
	Fins per inch	30
Compressor	Type	Axial, 6 Cylinder (HD6)
	Displacement (cc)	110
	Manufacturer	Harrison Division
	A/C pulley ratio	1.43:1
Accumulator	Type	Universal
	Height (mm.)	215.9
	Diameter (mm.)	90
Receiver	Type	Not Applicable
	Height (mm.)	"
	Diameter (mm.)	"
Refrigerant control (CCOT, TVS, etc.)		CCOT
Heater water valve (yes / no)		No
Refrigerant (R - 12, R - 134a, etc.)		R134a
Charge level (lbs. - oz.)		1 lb. 12 oz.
Cold engine lockout switch (yes / no)		HVAC Control Air Shut Off Until Water/Coolant Warms Up
Wide open throttle cutout switch (yes / no)		Yes

MVMA Specifications

Vehicle Line CAPRICE CLASSIC SEDAN
 Model Year 1994 Issued 8-93 Revised(*) _____

METRIC (U.S. Customary)

Model Code/Description

ALL

Convenience Equipment (standard, optional, n.a.)

	Clock (digital, analog)	Digital - In Radio
	Compass / thermometer	Compass, Mirror Mounted - Optional, Classic
	Console (floor, overhead)	Not Applicable
	Defroster, electric windshield	None
	Defroster, electric backlight	Optional
Electronic	Diagnostic monitor (integrated, individual)	Low Oil Level Indicator, Standard (Washer, Coolant, Fuel, Oil Level Indicators Standard on Classic LS)
	Instrument cluster (list instruments)	Speedo Fuel Temp
	Keyless entry	Optional, Classic LS Only
	Trip/finder (avg. spd. fuel)	Not Applicable
	Voice alert (list items)	Not Applicable
	Other	
	Fuel door lock (remote, key, electric)	Not Applicable
Lamps	Auto head on/off delay, dimming	Optional, Classic LS
	Cornering	Standard, Classic LS
	Courtesy (map, reading)	Courtesy (Door) - Standard, Classic LS Reading Lamps - Standard, Classic LS; Optional, Caprice Classic
	Door lock, ignition	None
	Engine compartment	Standard, RH Side
	Fog	None
	Glove compartment	Standard
	Trunk	Standard
	Illuminated entry system (list lamps, activation)	Standard (Interior Lights)
	Other	Center High-mounted Stop Lamp
Mirrors	Ashtray (Front)	Standard
	Day / night (auto, man.)	Manual
	L.H. (remote, pwr., heated)	Remote - Standard, Power Or Power Heated - Optional
	R.H.(convex, rmt, pwr, htd)	Manual-Std., Power Or Power Heated-Opt. (Convex Mirror)
	Visor vanity (RH/LH illum.)	Non-illum. - LH & RH, Standard / Optional RH - illum.
	Navigation system (describe)	Not Applicable
	Prkg. brake-auto release (warn. light)	Base Light

MVMA Specifications

Vehicle Line CAPRICE CLASSIC SEDAN
 Model Year 1994 Issued 9-93 Revised(*)

METRIC (U.S. Customary)

Model Code/Description ALL

Convenience Equipment (standard, optional, n.a.)

Power equipment	Deck lid(release, pull down)		Release - Optional
	Door locks (manual, auto., describe system)		Manual - Standard Power - Optional (Power - Standard On Classic)
	Seats	2 - 4 - 6 way, etc.	6-Way RH & LH, Optional Classic; LH Only, Optional Caprice; 6-Way LH Standard
		Reclining(R.H., L.H.)	Manual RH & LH On All Split Seats
		Memory (R.H., L.H., preset, recline)	None
		Support (lumbar, hip, thigh, etc.)	None
		Heated (R.H., L.H., other)	None
	Side windows		Power - Optional (Standard - Classic)
	Vent windows		None
	Rear windows		Not Applicable
Radio systems	Antenna (location, whip, w/shield, power)		Whip RH Front Fender. Power - Optional
	Stan.	AM, FM, stereo, tape, compact disc, graphic equalizer, theft deterrent, radio prep package, headphone jacks, etc.	AM/FM Stereo Seek. Scan. Clock - ETR
	Opt.		AM/FM Stereo Seek, Scan, Auto Reverse Cass., Clock ERS
			AM/FM Stereo Seek, Scan, Auto Reverse Cass., Clock ETR AM/FM Stereo Seek. Scan. CD. Clock ETR. W/Delco Lock (Anti-Theft)
	Speaker (number, location)		4 Speakers - 1 Each Front Door. 2 Rear Shelf
Roof: open air or fixed (flip-up, sliding, T)			Not Applicable
Speed control device			Cruise Control - Stepper Motor. Optional
Speed warn. dev. (light, buzzer, etc.)			Not Applicable
Tachometer (rpm)			"
Telephone system (describe)			"
Theft deterrent system			"

Trailer Towing

Towing capable	Yes / No	Class I (Base); Class III w/V92 (Optional)
Engine/transmission/axle	Std / Opt	(No Towing W/L99.) Trans - M30 Axle - 2.93 LT1 (Optional); M30 4L60E (Standard) 2.93 (Optional)
Tow class (I, II, III)*	Std / Opt	III (Optional)
Max. gross trailer wgt. (lbs.)	Std / Opt	5000 (Optional)
Max. trailer tongue load (lbs.)	Std / Opt	600 w/Wright Distr. Hitch (Optional)
Towing package available	Yes / No	V92

* Class I - 2,000 lbs. Class II - 3,500 lbs. Class III - 5,000 lbs.

MVMA Specifications

Vehicle Line CAPRICE CLASSIC SEDAN

Model Year 1994 Issued 9-93 Revised(*)

METRIC (U.S. Customary)

Vehicle Dimensions See Key Sheets for definitions

All dimensions to ground are for comparative purposes only. Dimensions are to be shown for all base body models of each vehicle line. SAE Ref. no. refers to the definition published in SAE Recommended Practice J1100 Motor Vehicle Dimensions, unless otherwise specified.

Model Code/Description

ALL

Width

SAE Ref. No.

Tread (front)	W101	1568 (61.8)
Tread (rear)	W102	1582 (62.3)
Vehicle width	W103	1968 (77.5)
Body width at Sg RP (front)	W117	1953 (76.9)
Vehicle width (front doors open)	W120	3589 (141.3)
Vehicle width (rear doors open)	W121	3468 (136.6)
Tumble-home (deg.)	W122	27.5
Outside mirror width	W410	2114 (83.2)

Length

Wheelbase	L101	2945 (115.9)
Vehicle length	L103	5439 (214.1)
Overhang (front)	L104	1059 (41.7)
Overhang (rear)	L105	1435 (56.5)
Upper structure length	L123	3143 (123.7)
Rear wheel C/L 'X' coordinate	L127	4475 (176.3)

Height **

Passenger distribution (front/rear)	PD1,2,3	Not Available	**
Trunk/cargo load			**
Vehicle height	H101	1415 (55.7)	
Cowl point to ground	H114	970 (38.2)	
Deck point to ground	H138	1063 (41.9)	
Rocker panel-front to ground	H112	258 (10.1)	
Rocker panel-rear to ground	H111	270 (10.6)	
Windshield slope angle (deg.)	H122	60.5	
Backlight slope angle (deg.)	H121	65.5	

Ground Clearance **

Front bumper to ground	H102	256 (10.1), EPA
Rear bumper to ground	H104	320 (12.6), EPA
Bumper to ground front at curb mass (wt.)	H103	283 (11.1), Curb
Bumper to ground rear at curb mass (wt.)	H105	360 (14.2), Curb
Angle of approach (deg.)	H108	16 EPA
Angle of departure (deg.)	H107	9.4 EPA
Ramp breakover angle (deg.)	H147	14.1 EPA, 9.9 GVM
Axle differential to ground (front/rear)	H153	193 (7.6)
Min. running ground clearance	H156	178.7 (7.0), Curb 157.0 (6.2), EPA
Location of min. run. grd. clear.		Rear Lower Trailing Arm Bracket

** All Vehicle Height And Ground Clearance Are Made Using EPA Loaded Vehicle Weight, Loading Conditions.

EPA Loaded Vehicle Weight is the Base Vehicle Weight Plus All Coolant and Fluids Necessary For Operation Plus 100% Of The Fuel Capacity, Plus The Weight Of All Options And Accessories Which Weigh Three Pounds Or More And Which Are Sold On At Least 33% Of The Car Line, Plus Two Occupants.

All Linear Dimensions Are in Millimeters (Inches).

MVMA Specifications

Vehicle Line CAPRICE CLASSIC SEDAN
 Model Year 1994 Issued 3-93 Revised(*)

METRIC (U.S. Customary) Vehicle Dimensions

See Key Sheets for Definitions

Model Code/Description

ALL

Front Compartment

SAE Ref. No.

SgRP front, 'X' coordinate	L31	3078 (121.2)
Effective head room	H61	996 (39.2)
Max. eff. leg room (accelerator)	L34	1072.0 (42.2)
SgRP to heel point	H30	220.0 (8.7)
SgRP to heel point	L53	876.0 (34.5)
Back angle (deg.)	L40	26.5
Hip angle (deg.)	L42	97
Knee angle (deg.)	L44	127
Foot angle (deg.)	L46	87
Design H-point front travel	L17	163.0 (6.4)
Normal driving & riding seat track trvl.	L23	143.0 (5.6)
Shoulder room	W3	1610.0 (63.4)
Hip room	W5	1448.0 (57.0)
*** Upper body opening to ground	H50	1347 (53.0)
Steering wheel maximum diameter*	W9	387.0 (15.2)
Steering wheel angle (deg.)	H18	19
Accel. heel pt. to steer. whl. cntr	L11	555 (21.9)
Accel. heel pt. to steer. whl. cntr	H17	629.0 (24.8)
Undepressed floor covering thickness	H87	9.0 (0.35)

Front Compartment Int. Dim. Are Measured With The Seating Ref. Pt.
 (SgRP) 20 mm (1 Seat Adjuster Notch) Forward of Rearmost Seat Position.

Rear Compartment

SgRP point couple distance	L50	882.0 (34.7)
Effective head room	H63	963 (37.9)
Min. effective leg room	L51	1002 (39.5)
SgRP (second to heel)	H31	292.0 (11.5)
Knee clearance	L48	64 (2.5)
Shoulder room	W4	1610.0 (63.4)
Hip room	W5	1445.0 (56.9)
*** Upper body opening to ground	H51	1362 (53.6)
Back angle (deg.)	L41	25
Hip angle (deg.)	L43	93
Knee angle (deg.)	L45	110
Foot angle (deg.)	L47	127.5
Depressed floor covering thickness	H73	18.0

Luggage Compartment

Usable luggage capacity L (cu. ft.)	V1	577.4 (20.4)
*** Liftover height	H:95	785.5 (30.9)

Interior Volumes (EPA Classification)

Vehicle class		Large
Interior volume index (cu. ft.)**		134.6 = Pass. Area 114.2 (Frt. 60.2 + Rr. 54.0) + Trunk Area 20.4
Trunk / cargo index (cu. ft.)		20.4

* See page 14.

** Includes passenger and trunk / cargo index - see definition page 33.

*** EPA Loaded Vehicle Weight, Loading Conditions.

All Linear Dimensions Are in Millimeters (Inches).

MVMA Specifications

Vehicle Line CAPRICE CLASSIC SEDAN
 Model Year 1994 Issued 3-93 Revised(*)

METRIC (U.S. Customary) Vehicle Dimensions

See Key Sheets for Definitions

Model Code/Description

ALL

Station Wagon / MPV** - Third Seat

SAE Ref. No. (NOT APPLICABLE)

	SAE Ref. No.	(NOT APPLICABLE)
Seat facing direction	SD1	
SgRP couple distance	L85	
Shoulder room	W85	
Hip Room	W88	
Effective leg room	L86	
Effective head room	H86	
SgRP to heel point	H87	
Knee clearance	L87	
Back angle (deg.)	L88	
Hip angle (deg.)	L89	
Knee angle (deg.)	L90	
Foot angle (deg.)	L91	

Station Wagon / MPV** Cargo Space

(NOT APPLICABLE)

	SAE Ref. No.	(NOT APPLICABLE)
Cargo length (open front)	L200	
Cargo length (open second)	L201	
Cargo length (closed front)	L202	
Cargo length (closed second)	L203	
Cargo length at belt (front)	L204	
Cargo length at belt (second)	L205	
Cargo width (wheelhouse)	W201	
Rear opening width at floor	W203	
Opening width at belt	W204	
Min. rear opening width above belt	W205	
Cargo height	H201	
Rear opening height	H202	
* Tailgate to ground height	H250	
Front seat back to load floor height	H197	
Cargo volume index cu. m. (cu. ft.)	V2	
Hidden cargo vol. index cu.m. (cu. ft.)	V4	
Cargo volume index-rear of 2-seat	V10	
Cargo Volume index**	V6	
Cargo width at floor**	W500	
Maximum cargo height**	H505	

Hatchback - Cargo Space

(NOT APPLICABLE)

	SAE Ref. No.	(NOT APPLICABLE)
Cargo length at front seatback height	L208	
Cargo length at floor (front)	L209	
Cargo length at second seatback height	L210	
Cargo length at floor (second)	L211	
Front seatback to load floor height	H197	
Second seatback to load floor height	H198	
Cargo volume index cu. m. (cu. ft.)	V3	
Hidden cargo vol. index cu.m. (cu. ft.)	V4	
Cargo volume index-rear of 2-seat	V11	

* EPA Loaded Vehicle Weight, Loading Conditions

** MPV - Multipurpose Vehicle

All Linear Dimensions Are In Millimeters (Inches).

MVMA Specifications

Vehicle Line CAPRICE CLASSIC SEDAN
 Model Year 1994 issued 9-93 Revised(*)

METRIC (U.S. Customary)

Model Code/ Description ALL

Vehicle Fiducial Marks

Fiducial Mark Number*	Define Coordinate Location
Front	X - Fiducial mark to vertical zero grid line - front measured horizontally, from the zero grid line to the front fiducial mark located on top of the front seat adjuster mounting bolt.
	Y - Fiducial mark to centerline of car - front, width measurement made from centerline car to fiducial mark located on top of the front seat adjuster mounting bolt.
	Z - Fiducial mark to horizontal zero grid line - front, measured vertically from zero grid line to front fiducial mark located on top of the front seat adjuster mounting bolt.
Rear	X - Fiducial mark to vertical zero grid line - rear, measured horizontally from the zero grid line to rear fiducial mark located on the rail (compartment pan - longitudinal).
	Y - Fiducial mark to centerline of car - rear, width measurement made from centerline of car to fiducial mark located on the rail (compartment pan - longitudinal).
	Z - Fiducial mark to horizontal zero grid line - rear, measured vertically from the zero grid line to rear fiducial mark located on the rail (compartment pan - longitudinal).
NOTE: Provide 3 of 4 Fiducial Mark Locations	
Front	W21** 564 (22.2)
	L54** 2754 (108.4)
	H81** 509 (20.0)
	*** H181** 348 (13.7), Curb
	*** H163** 392 (15.4)
Rear	W22** 254 (10.0)
	L55** 5533 (217.8)
	H82** 586 (23.1)
	*** H182** 446 (17.6)
	*** H184** 359 (14.1)

* Reference - SAE Recommended Practice, J182, Motor Vehicle Fiducial Marks.
 ** Reference - SAE Recommended Practice J1100 - Motor Vehicle Dimensions.
 *** EPA Loaded Vehicle Weight, Loading Conditions.
 All Linear Dimensions Are In Millimeters (Inches).

MVMA Specifications

METRIC (U.S. Customary)

Vehicle Line CAPRICE CLASSIC SEDAN

Model Year 1994 Issued 9-93 Revised(*) _____

Code	Model	VEHICLE MASS (weight)				SHIPPING MASS kg (lb) ***	ETWC** Code	% PASS MASS DISTRIBUTION			
		CURB MASS. kg. (lb.)*			PASS IN FRONT			PASS IN REAR			
		Front	Rear	Total	Front			Rear	Front	Rear	
CAPRICE CLASSIC 1BL19 4-Dr. Notchback Sedan (L99 & M30)		1034 (2280)	808 (1781)	1842 (4061)	1786 (3937)	Z	47.4	52.6	17.4	82.6	
CAPRICE CLASSIC LS 1BN19 (W/Z09) 4-Dr. Notchback Sedan (L99 & M30)		1039 (2291)	811 (1788)	1850 (4078)	1794 (3954)	Z	47.4	52.6	17.4	82.6	
CAPRICE W/POLICE PKG. 1BL19 & 9C1 4-Dr. Notchback Sedan (LT1 & M30)		1069 (2357)	847 (1867)	1916 (4224)	1860 (4100)	AA	47.4	52.6	17.4	82.6	

* Reference - SAE J1100 Motor vehicle dimensions, curb weight definition.
 ** ETWC - Equivalent Test Weight Class - basis for U.S. Environmental Protection Agency emission certifications.
 Refer to ETWC code legend below for test weight class.

ETWC LEGEND

A = 1000	I = 2000	O = 3000	Y = 4000
B = 1125	J = 2125	R = 3125	Z = 4250
C = 1250	K = 2250	S = 3250	AA = 4500
D = 1375	L = 2375	T = 3375	BB = 4750
E = 1500	M = 2500	U = 3500	CC = 5000
F = 1625	N = 2625	V = 3625	DD = 5250
G = 1750	O = 2750	W = 3750	EE = 5500
H = 1875	P = 2875	X = 3875	FF = 5750

*** Shipping Mass (weight) = Curb Weight Less:
56 (124)

20.2 gal. * 2.776 = kg. * 2.2046 = lbs.

MVMA Specifications

METRIC (U.S. Customary)

Vehicle Line CAPRICE CLASSIC SEDAN
 Model Year 1994 Issued 9-93 Revised _____

		Optional Equipment Differential Mass (weight)*			Remarks Restrictions, Requirements
Code	Equipment	MASS, kg. (lb.)			
		Front	Rear	Total	
AA7	Window - Power Operated	1.8 (4.0)	1.0 (2.2)	2.8 (6.2)	
AG1	Seat Adjuster - 6 Way Power Driver Only	3.2 (7.0)	1.0 (2.2)	4.2 (9.2)	
AG2	Seat Adjuster - 6 Way Power	3.2 (7.0)	1.0 (2.2)	4.2 (9.2)	
AM6	Seat Front Split 3 Passenger	6.0 (13.2)	4.8 (10.6)	10.8 (23.8)	
AN4	Child Restraint Provisions	0 (0)	.4 (.9)	.4 (.9)	
AP9	Convenience - Net	0 (0)	.2 (.4)	.2 (.4)	
AS7	Seat - Deluxe 45/45	7.4 (16.3)	4.8 (10.6)	12.2 (26.9)	
AU0	Lock Control - Remote Entry	.6 (1.3)	.4 (.9)	1.0 (2.2)	
AU3	Lock - Side Door, Electric	.6 (1.3)	.6 (1.3)	1.2 (2.6)	
A75	Cushion - Front Seat H/D	1.6 (3.5)	1.6 (3.5)	3.2 (7.0)	
A76	Cushion - Rear Seat H/D	.4 (.9)	.2 (.4)	.6 (1.3)	
A90	Lock - Rear Compartment Lid, Remote Control Electric	-.2 (-.4)	.8 (1.7)	.6 (1.3)	

* Also see Engine - General Section for dressed engine mass (weight).

MVMA Specifications

METRIC (U.S. Customary)

Vehicle Line CAPRICE CLASSIC SEDAN
 Model Year 1994 Issued 9-93 Revised _____

		Optional Equipment Differential Mass (weight)*			
Code	Equipment	MASS, kg. (lb.)			Remarks Restrictions, Requirements
		Front	Rear	Total	
B05	Interior Ornamentation Load Comp	-2 (-4)	.8 (1.7)	.6 (1.3)	
B18	Ornamentation - Interior, Deluxe	.2 (.4)	0 (0)	.2 (.4)	
B4U	Sport Performance Package	3.0 (6.6)	3.6 (7.9)	6.6 (14.5)	
B45	Trim Equipment Delete Fleet	0 (0)	-2.0 (-4.4)	-2.0 (-4.4)	
B48	Trim - Luggage Compartment	0 (0)	3.2 (7.0)	3.2 (7.0)	
B81	Exterior Ornamentation - Body Side Delete	-.6 (-1.3)	-1.0 (-2.2)	-1.6 (-3.5)	
C49	Defogger - Rear Window, Electric	.2 (.4)	.2 (.4)	.4 (.8)	
C71	Lamp - Interior Front Door	.2 (.4)	0 (0)	.2 (.4)	
C96	Lamps	.2 (.4)	0 (0)	.2 (.4)	
DC4	Mirror - I/S, R/V Tilt R/Lamp	.2 (.4)	0 (0)	.2 (.4)	
DD2	Mirror - I/S, Sunshade, Covered	.2 (.4)	0 (0)	.2 (.4)	
DD9	Mirror Chrome Electric (Export)	.8 (1.8)	0 (0)	.8 (1.8)	

* Also see Engine - General Section for dressed engine mass (weight).

MVMA Specifications

METRIC (U.S. Customary)

Vehicle Line CAPRICE CLASSIC SEDAN
 Model Year 1994 issued 9-93 Revised _____

Optional Equipment Differential Mass (weight)*

Code	Equipment	MASS, kg. (lb.)			Remarks Restrictions, Requirements
		Front	Rear	Total	
DG7	Mirror - O/S. Left & Right, Electric Painted	.4 (.9)	0 (0)	.4 (.9)	
DL8	Mirror - Outside Rear	.6 (1.3)	0 (0)	.6 (1.3)	
D42	Shade - Rear Compartment Security	-.6 (-1.3)	3.4 (7.5)	2.8 (6.2)	
D55	Console Front Compartment Floor Var. 1	2.0 (4.4)	1.0 (2.2)	3.0 (6.6)	
D64	Mirror - Visor (Illuminated)	.2 (.4)	0 (0)	.2 (.4)	
D84	Paint - Custom Two-Tone	.2 (.4)	.2 (.4)	.4 (.8)	
FE2	Suspension System - Ride, Handling	2.8 (6.2)	8.2 (18.0)	11.0 (24.2)	
FE3	Suspension System - Sport	3.2 (7.1)	9.8 (21.6)	13.0 (28.7)	
F01	Frame Heavy Duty	4.0 (8.8)	4.0 (8.8)	8.0 (17.6)	
F41	Suspension System - Front/Rear, Firm Ride, Handling	3.0 (6.6)	8.0 (17.6)	11.0 (24.2)	
GU4	Axle - Rear (3.08 Ratio)	0 (0)	14.0 (30.9)	14.0 (30.9)	
GU5	Rear Axle - 3.23 Ratio	0 (0)	7.0 (15.4)	7.0 (15.4)	

* Also see Engine - General Section for dressed engine mass (weight).

MVMA Specifications

METRIC (U.S. Customary)

Vehicle Line CAPRICE CLASSIC SEDAN
 Model Year 1994 Issued 9-93 Revised _____

		Optional Equipment Differential Mass (weight)*			
Code	Equipment	MASS, kg. (lb.)			Remarks Restrictions, Requirements
		Front	Rear	Total	
GW9	Rear Axle - 2.93 Ratio	0 (0)	15.0 (33.1)	15.0 (33.1)	
G80	Axle - Rear (Limited Slip)	0 (0)	3.6 (7.9)	3.6 (7.9)	1BA00 & GU4/GU5
G80	Axle - Rear (Limited Slip)	0 (0)	2.8 (6.2)	2.8 (6.2)	1BA00 & GM8/GW9
IHD	Trim - Interior Design	.2 (.4)	.2 (.4)	.4 (.8)	
IHN	Trim - Interior Design	1.8 (4.0)	1.8 (4.0)	3.6 (7.9)	
IQC	Trim - Interior Design AM6	.6 (1.3)	.6 (1.3)	1.2 (2.6)	
IQD	Trim - Interior Design	.8 (1.8)	.8 (1.8)	1.6 (3.5)	
IQE	Trim - Interior Design AM6	.6 (1.3)	.6 (1.3)	1.2 (2.6)	
IQN	Trim - Interior Design	1.8 (4.0)	1.8 (4.0)	3.6 (7.9)	
IQ2	Trim - Interior Design	1.6 (3.5)	1.6 (3.5)	3.2 (7.0)	
IRD	Trim - Interior Design A52	.2 (.4)	.2 (.4)	.4 (.8)	
IRN	Trim - Interior Design A52	1.8 (4.0)	1.8 (4.0)	3.6 (7.9)	

* Also see Engine - General Section for dressed engine mass (weight).

MVMA Specifications

METRIC (U.S. Customary)

Vehicle Line CAPRICE CLASSIC SEDAN
 Model Year 1994 Issued 3-93 Revised _____

Optional Equipment Differential Mass (weight)*

Code	Equipment	MASS, kg. (lb.)			Remarks Restrictions, Requirements
		Front	Rear	Total	
JA2	Brake - System Heavy Duty	0 (0)	13.4 (29.5)	13.4 (29.5)	1BL19 & GU5
JA2	Brake - System Heavy Duty	0 (0)	15.0 (33.1)	15.0 (33.1)	1BL19 & GU2
JA9	Brake Heavy Weight, Disc/Disc	0 (0)	11.0 (24.3)	11.0 (24.3)	1BL19 & GU5
KC4	Cooling System - Engine Oil	1.4 (3.1)	0 (0)	1.4 (3.1)	
KD1	Cooling System - Transmission Oil	2.0 (4.4)	0 (0)	2.0 (4.4)	
KG9	Generator 140 Amp	1.4 (3.1)	0 (0)	1.4 (3.1)	
K05	Heater - Engine Block	.4 (.9)	0 (0)	.4 (.9)	
K34	Cruise Control Auto Electronic	1.6 (3.5)	0 (0)	1.6 (3.5)	
LT1	Engine 8 Cylinder, 5.7L, MFI HO	2.0 (4.4)	0 (0)	2.0 (4.4)	
NK4	Steering Wheel - Sport, Leather	.2 (.4)	0 (0)	.2 (.4)	
NM8	Emission System - Leaded Fuel	-.8 (-1.8)	-.8 (-1.8)	-1.6 (-3.5)	
N10	Dual Exhaust System	6.0 (13.2)	12.8 (28.2)	18.8 (41.4)	

* Also see Engine - General Section for dressed engine mass (weight).

MVMA Specifications

METRIC (U.S. Customary)

Vehicle Line CAPRICE CLASSIC SEDAN

Model Year '994 Issued 9-93 Revised _____

		Optional Equipment Differential Mass (weight)*			
Code	Equipment	MASS, kg. (lb.)			Remarks Restrictions, Requirements
		Front	Rear	Total	
N81	Fullsize Spare Tire	-1.4 (-3.1)	8.0 (17.6)	6.6 (14.5)	1BL19 & PH1 & QNP
N91	Wheel Cover - Simulated Wire W/Lock	1.8 (4.0)	1.8 (4.0)	3.6 (7.9)	
N92	Wire Wheel Covers (9C1)	2.4 (5.3)	2.4 (5.3)	4.8 (10.6)	
N97	Wheel 15, HD	2.6 (5.7)	2.6 (5.7)	5.2 (11.4)	
PA5	Hubcaps - Wheel	-1.6 (-3.5)	-1.6 (-3.5)	-3.2 (-7.0)	
PB1	Cover - Wheel 15 in.	.2 (.4)	.2 (.4)	.4 (.8)	
PB4	Lock - Wheels	0 (0)	.2 (.4)	.2 (.4)	
PD4	Wheel - 15 x 7, Light Metal	-.8 (-1.8)	-.8 (-1.8)	-1.6 (-3.5)	
QA0	Wheel 17 x 8.5 Aluminum Styled	5.2 (11.5)	5.2 (11.5)	10.4 (22.9)	
QBJ	Tire All P255/50ZR17 BW R/PE	4.4 (9.7)	4.4 (9.7)	8.8 (19.4)	
QMV	Tire All P235/70R15 WS1 R/PE	2.4 (5.3)	2.4 (5.3)	4.8 (10.6)	
QNP	Tire - P225/70R15/N	.8 (1.8)	.8 (1.8)	1.6 (3.5)	

* Also see Engine - General Section for dressed engine mass (weight).

MVMA Specifications

METRIC (U.S. Customary)

Vehicle Line CAPRICE CLASSIC SEDAN

Model Year 1994 Issued 9-93 Revised _____

Optional Equipment Differential Mass (weight)*

Code	Equipment	MASS, kg. (lb.)			Remarks Restrictions, Requirements
		Front	Rear	Total	
QQG	Tire - P235/70R15	2.4 (5.3)	2.4 (5.3)	4.8 (10.6)	1BL19 & R4Z
QQG	Tire - P235/70R15	1.4 (3.1)	1.4 (3.1)	2.8 (6.2)	1BL19 & R4Y
QQR	Tire P235/70 R15 WS1 R/PE ST	1.4 (3.1)	1.4 (3.1)	2.8 (6.2)	
TL4	Grille Painted	.4 (.9)	0 (0)	.4 (.9)	
TL6	Grille - Black	.6 (1.3)	0 (0)	.6 (1.3)	
T43	Rear Spoiler	0 (0)	1.4 (3.1)	1.4 (3.1)	
T61	Lighting Daytime Running	.6 (1.3)	0 (0)	.6 (1.3)	
T82	Headlamps - Twilight Sentinel	.4 (.9)	0 (0)	.4 (.9)	
T87	Lamps - Cornering	.4 (.9)	0 (0)	.4 (.9)	
UL5	Radio - Delete	-1.0 (-2.2)	-2 (-4)	-1.2 (-2.2)	
UM6	Radio - AM/FM Stereo, Seek & Scan, Cassette, Clock	.6 (1.3)	.2 (.4)	.8 (1.7)	
UQ5	Speaker System - 4 Dual	.2 (.4)	.8 (1.8)	1.0 (2.2)	

* Also see Engine - General Section for dressed engine mass (weight).

MVMA Specifications

METRIC (U.S. Customary)

Vehicle Line CAPRICE CLASSIC SEDAN
 Model Year 1994 Issued 9-93 Revised _____

		Optional Equipment Differential Mass (weight)*			
Code	Equipment	MASS, kg. (lb.)			Remarks Restrictions, Requirements
		Front	Rear	Total	
U1C	Radio - AM/FM Stereo Seek & Scan	.8 (1.8)	.2 (.4)	1.0 (2.2)	
U11	Cluster - Police Includes Gages	.4 (.9)	0 (0)	.4 (.9)	
U75	Antenna - Power, Radio	1.0 (2.2)	0 (0)	1.0 (2.2)	
VK3	License Plate Rear Mounted PKG-EXP	.4 (.9)	0 (0)	.4 (.9)	
V03	Cooling System - Extra Capacity	.6 (1.3)	-2 (-4)	.4 (.9)	
V08	Radiator - Heavy Duty (Req. W/V92)	5.6 (12.3)	0 (0)	5.6 (12.3)	
1T1	Hose - Radiator & Heater (Spl.) Sil. Rub.	.4 (.9)	0 (0)	.4 (.9)	
122	Anti-Corrosion Hot Melt	1.0 (2.2)	1.0 (2.2)	2.0 (4.4)	
142	Trim Comb - Leather, Light Gray	.4 (.9)	.4 (.9)	.8 (1.8)	
5AN	Tire - P225/70HR 15	4.2 (9.3)	4.2 (9.3)	8.4 (18.5)	
5AQ	Tire - P225/70HR 15	4.2 (9.3)	4.2 (9.3)	8.4 (18.5)	1BL19 & R4Z
5AQ	Tire - P225/70HR 15	1.4 (3.1)	1.4 (3.1)	2.8 (6.2)	1BL19 & R4Y

* Also see Engine - General Section for dressed engine mass (weight).

MVMA Specifications

METRIC (U.S. Customary)

Vehicle Line CAPRICE CLASSIC SEDAN
 Model Year 1994 Issued 3-93 Revised _____

Optional Equipment Differential Mass (weight)*

Code	Equipment	MASS, kg. (lb.)			Remarks Restrictions, Requirements
		Front	Rear	Total	
6A3	Mat - H/D Front & Rear	2.4 (5.3)	2.4 (5.3)	4.8 (10.6)	
6C9	Conduit - Two-Way Cable	.4 (.8)	.3 (.7)	.7 (1.5)	
6F8	Tray - Ash Side Front Doors	.2 (.4)	0 (0)	.2 (.4)	
6G2	Reinforced - Roof Panel	1.6 (3.5)	1.6 (3.5)	3.2 (7.0)	
6H6	Auto Trunk Opener	0 (0)	.2 (.4)	.2 (.4)	
6J1	Wiring - Ignition & Main Power	.8 (1.8)	.4 (.8)	1.2 (2.6)	
6J2	Wiring - Headlight, Flash, Grille Light	.2 (.4)	0 (0)	.2 (.4)	
6J3	Wiring - Headlight, Flash, Grille Left Speaker	.6 (1.3)	.4 (.9)	1.0 (2.2)	
6J6	Lamp Package - Rear Panel Lights	0 (0)	1.6 (3.5)	1.6 (3.5)	
6N8	Handle - Rear Seat Assist	.2 (.4)	.2 (.4)	.4 (.8)	
7B3	Suspension - Special Handling	3.8 (8.4)	9.2 (20.3)	13.0 (28.7)	
7L9	Cooler - Hydraulic Steering Oil	.4 (.9)	0 (0)	.4 (.9)	

* Also see Engine - General Section for dressed engine mass (weight).

MVMA Specifications

METRIC (U.S. Customary)

Vehicle Line

CAPRICE CLASSIC SEDAN

Model Year

1994

Issued

9-93

Revised

Optional Equipment Differential Mass (weight)*

Code	Equipment	MASS, kg. (lb.)			Remarks Restrictions, Requirements
		Front	Rear	Total	
7P8	Cooler - Engine Oil	1.8 (4.0)	0 (0)	1.8 (4.0)	
7X6	Spotlamp - Left Halogen Pillar Mount	1.6 (3.5)	0 (0)	1.6 (3.5)	
7X7	Spotlamp - Left & Right Halogen	3.4 (7.5)	0 (0)	3.4 (7.5)	
7Z5	Fuse Box	.4 (.9)	0 (0)	.4 (.9)	
9C1	Police Car	6.8 (15.0)	6.6 (14.5)	13.4 (29.5)	
9C6	Taxi Cab	3.4 (7.5)	3.2 (7.1)	6.6 (14.6)	

* Also see Engine - General Section for dressed engine mass (weight).

MVMA Specifications

METRIC (U.S. Customary)

Exterior Vehicle And Body Dimensions – Key Sheet

Exterior Width

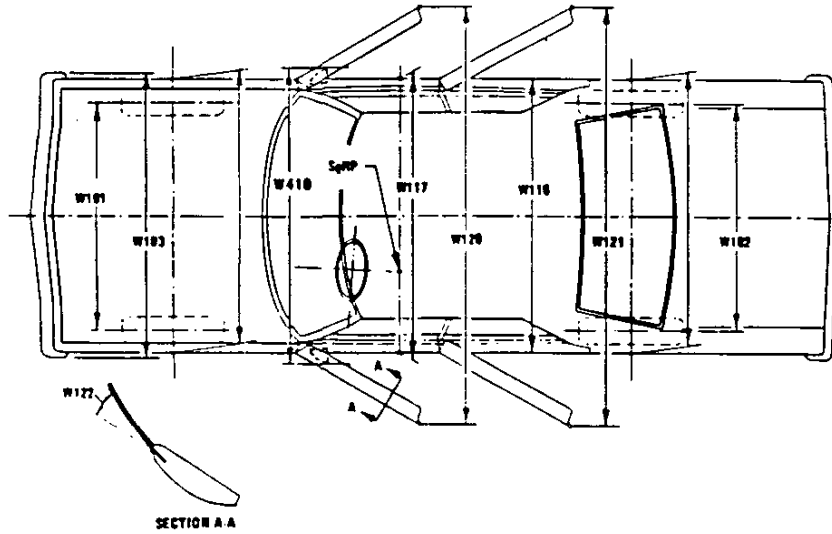

Exterior Length & Height

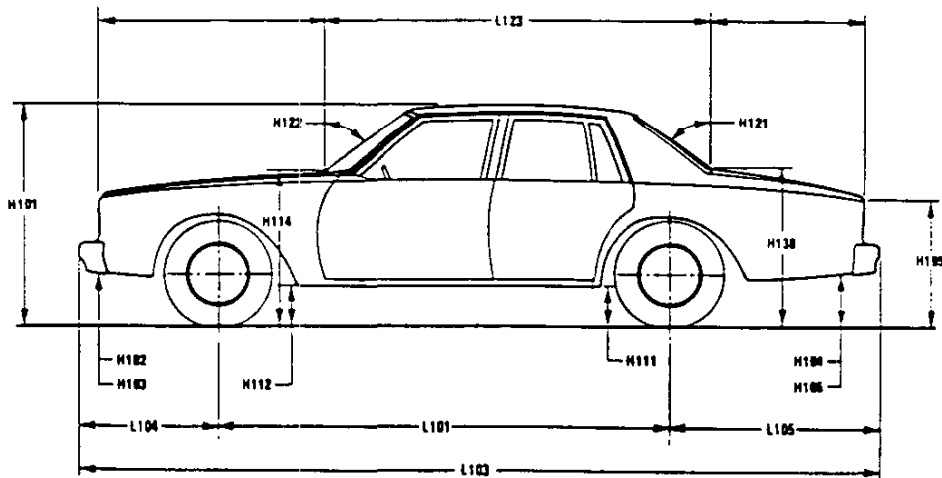

Exterior Ground Clearance

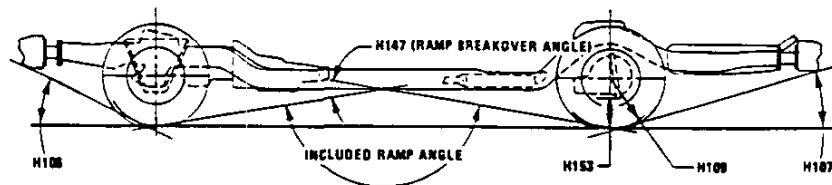

MVMA Specifications Form

METRIC (U.S. Customary)

Interior Vehicle And Body Dimensions – Key Sheet

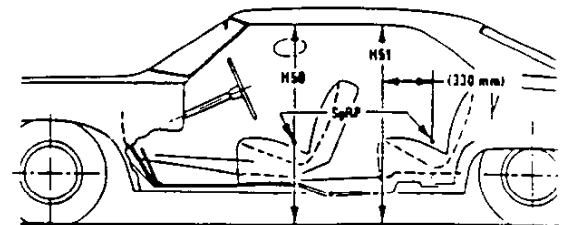
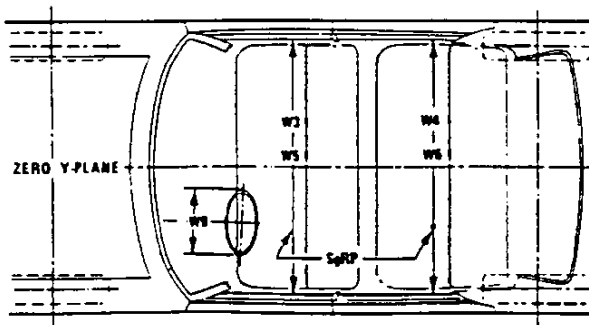
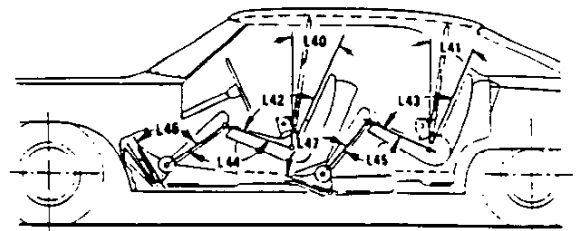
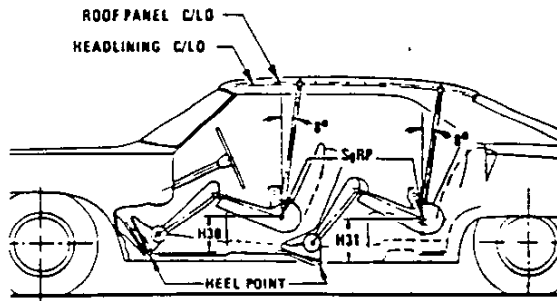
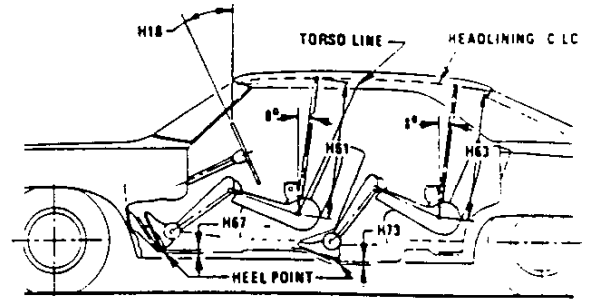
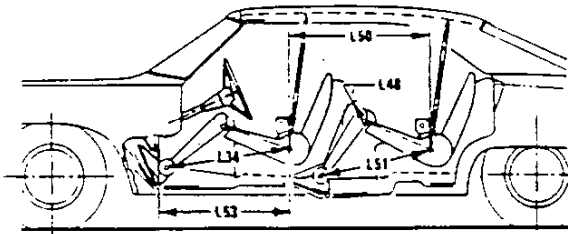

MVMA Specifications
METRIC (U.S. Customary)

Interior Vehicle And Body Dimensions – Key Sheet

Third Seat

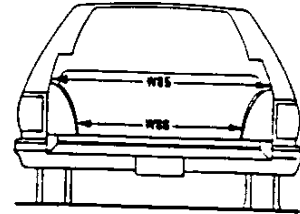
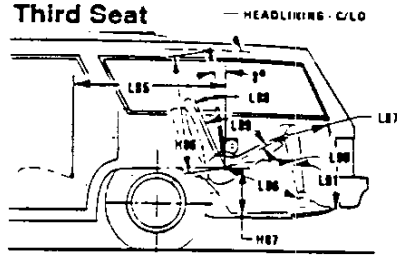

Cargo Space

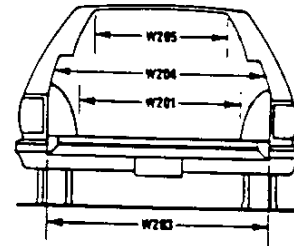
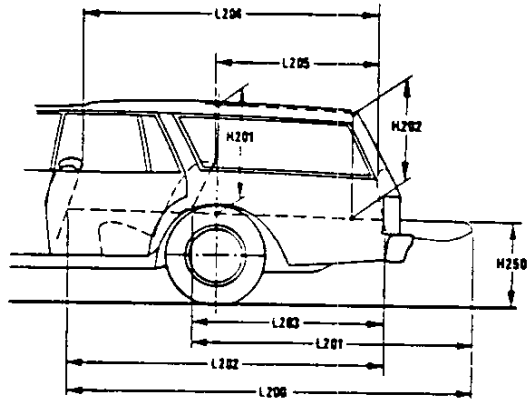

Station Wagon

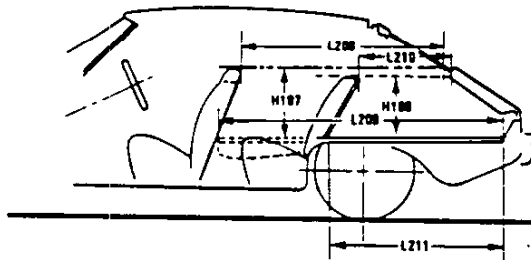

Hatchback

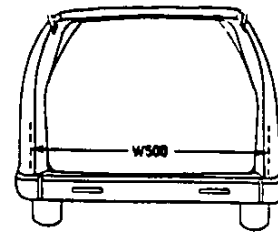
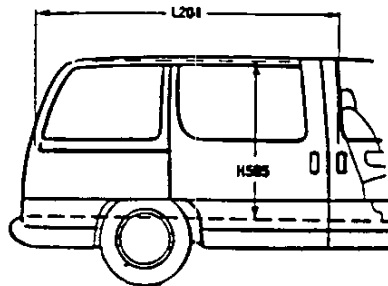

Multipurpose Vehicle

MVMA Specifications

METRIC (U.S. Customary)

Exterior Vehicle And Body Dimensions – Key Sheet Dimensions Definitions

Seating Reference Point

SEATING REFERENCE POINT means the manufacturer's design reference point which –
(a) Establishes the rearmost normal design driving or riding position of each designated seating position in a vehicle;
(b) Has coordinates established relative to the design vehicle structure;
(c) Simulates the position of the pivot center of the human torso and thigh; and
(d) Is the reference point employed to position the two dimensional templates described in SAE Recommended Practice J826, "Devices for Use in Defining and Measuring Vehicle Seating Accommodations."

Width Dimensions

- W101 TREAD – FRONT. The dimension measured between the tire centerlines at the ground.
- W102 TREAD – REAR. The dimension measured between the tire centerlines at the ground. In case of dual wheels, the dimension will be measured to the centerline of tire and wheel assemblies.
- W103 VEHICLE WIDTH. The maximum dimension measured between the widest point on the vehicle, excluding exterior mirrors, flexible mud flaps, marker lamps, but including bumpers, moldings, sheet metal protrusions or dual wheels, if standard equipment.
- W117 BODY WIDTH AT S_gRP – FRONT. The dimension measured laterally between the widest points on the body at the S_gRP-front, excluding door handles, applied moldings, or appliques.
- W120 VEHICLE WIDTH – FRONT DOORS OPEN. The dimension measured between the widest point on the front doors in maximum hold-open position.
- W121 VEHICLE WIDTH – REAR DOORS OPEN. The dimension measured between the widest point on the rear doors in maximum hold-open position. For vehicles with a rear door on only one side, this dimension is to the zero "Y" plane.
- W122 TUMBLE – HOME, STRAIGHT SIDE GLASS. The angle measured from a vertical to the outside surface of the front door glass at the S_gRP "X" plane.
CURVED SIDE GLASS. The angle measured from a vertical to a chord extending from the upper DLO to the lower DLO at the outside surface of the front door glass at the front S_gRP "X" plane.
- W410 OUTSIDE MIRROR WIDTH. The dimension between the widest point on the outside mirrors. The standard right and left mirror adjusted for normal driving will be shown unless otherwise noted. When only one outside mirror is standard, the dimension will be to the zero "Y" plane.

Length Dimensions

- L101 WHEELBASE (WB). The dimension measured longitudinally between front and rear wheel centerlines. In case of dual rear axles, the dimension shall be to the midpoint of the centerlines of the rear wheels.
- L103 VEHICLE LENGTH. The maximum dimension measured longitudinally between the foremost point and the rearmost point on the vehicle, including bumper, bumper guards, tow hooks and/or rub strips, if standard equipment.
- L104 OVERHAND – FRONT. The dimension measured longitudinally from the centerline of the front wheels to the foremost point on the vehicle including bumper, bumper guards, tow hooks and/or rub strips, if standard equipment.
- L105 OVERHANG – REAR. The dimension measured longitudinally from the centerline of the rear wheels; or in the case of dual rear axles, the dimension shall be the midpoint of the centerlines of the rear wheels, to the rearmost point on the vehicle including rear bumpers, bumper guards, tow hooks and rub strips, if standard equipment.

- L123 UPPER STRUCTURE LENGTH. The dimension measured longitudinally from the cowl point to the deck point.
- L127 REAR WHEEL CENTERLINE "X" COORDINATE or in the case of dual rear axles, the coordinate shall be the midpoint of the distance between the rear axle centerlines.

Height Dimensions

- H101 VEHICLE HEIGHT. The dimension measured vertically from the highest point on the vehicle body to ground.
- H111 ROCKER PANEL – REAR TO GROUND. The dimension measured vertically from the bottom of the rocker or side quarter panel at the front of the rear wheel opening excluding flanges, to ground.
- H112 ROCKER PANEL – FRONT TO GROUND. The dimension measured vertically from the foremost point on the bottom of the rocker panels, excluding flanges, to ground.
- H114 COWL POINT TO GROUND. Measured at zero "Y" plane.
- H121 BACKLIGHT SLOPE ANGLE. The angle between the vertical reference line and the surface of backlight at vehicle zero "Y" plane. For curve backlight, the angle is to chord of backlight arc from lower DLO to upper DLO.
- H122 WINDSHIELD SLOPE ANGLE. The angle between the vertical reference line and a chord of the windshield arc running from the lower DLO to the upper DLO at the vehicle zero "Y" plane. In the case of wrap over glass, the angle to be measured will be formed by a chord 457 mm (18.0 in.) long drawn from the lower DLO to the intersecting point on the windshield.
- H138 DECK POINT TO GROUND. Measured at zero "Y" plane.
- H109 STATIC LOAD – TIRE RADIUS – REAR. Specified by the manufacturer in accordance with composite TIRE SECTION STANDARD.

Ground Clearance Dimensions

- H102 FRONT BUMPER TO GROUND. The minimum dimension measured vertically from the lowest point on the front bumper to ground, including bumper guards, if standard equipment.
- H103 FRONT BUMPER TO GROUND – CURB MASS (WT.). Measured in the same manner as H102.
- H104 REAR BUMPER TO GROUND. The minimum dimension measured vertically from the lowest point on the rear bumper to ground, including bumper guards, if standard equipment.
- H105 REAR BUMPER TO GROUND – CURB MASS (WT.). Measured in the same manner as H104.
- H106 ANGLE OF APPROACH. The angle measured between a line tangent to the front tire static loaded radius arc and the initial point of structural interference forward of the front tire to ground. The limiting structural component shall be designated.
- H107 ANGLE OF DEPARTURE. The angle measured between a line tangent to the rear tire static loaded radius arc and the initial point of structural interference rearward of the rear tire to ground. The limiting component shall be designated.
- H147 RAMP BREAKOVER ANGLE. The angle measured between two lines tangent to the front and rear tire static loaded radius and intersecting at a point on the underside of the vehicle which defines the largest ramp over which the vehicle can roll.
- H153 REAR AXLE DIFFERENTIAL TO GROUND. The minimum dimension measured from the rear axle differential to ground.
- H156 MINIMUM RUNNING GROUND CLEARANCE. The minimum dimension measured from the sprung vehicle to ground. Specify location.

MVMA Specifications

METRIC (U.S. Customary)

Interior Vehicle And Body Dimensions - Key Sheet Dimensions Definitions

Glass Areas

- S1 Windshield area.
- S2 Side windows area. Includes the front door, rear door, vents, and rear quarter windows on both sides of the vehicle.
- S3 Backlight areas.
- S4 Total area. Total of all areas (S1 + S2 + S3).

Fiducial Mark Dimensions

- Fiducial Mark - Number 1**
- L54 "X" coordinate.
- W21 "Y" coordinate.
- H81 "Z" coordinate.
- H161 Height "Z" coordinate to ground at curb weight.
- H163 Height "Z" coordinate to ground.
- Fiducial Mark - Number 2**
- L55 "X" coordinate.
- W22 "Y" coordinate.
- W82 "Z" coordinate.
- H162 Height "Z" coordinate to ground at curb weight.
- H164 Height "Z" coordinate to ground.

Front Compartment Dimensions

- L11 ACCELERATOR HEEL POINT TO STEERING WHEEL CENTER. The dimension measured horizontally from the AHP to the intersection of the steering column centerline and a plane tangent to the upper surface of the steering wheel rim.
- L17 DESIGN H-POINT - FRONT TRAVEL. The dimension measured horizontally between the design H-point - front in the foremost and rearmost seat track positions. (See SAE J1100)
- L23 NORMAL DRIVING AND RIDING SEAT TRACK TRAVEL. The dimension measured horizontally between a point on the design H-point travel line from the SgRP to the displaced point on the design H-point travel line with the seat moved to the foremost seat position, but not to include seat track travel used for purposes other than normal driving and riding positions. (See SAE J1100).
- L31 SgRP - FRONT. "X" COORDINATED.
- L34 MAXIMUM EFFECTIVE LEG ROOM - ACCELERATOR. The dimension measured along a line from the ankle pivot center to the SgRP - front plus 254 mm (10.0 in.) measured with right foot on the undepressed accelerator pedal. For vehicles with SgRP to heel (H30) greater than 18 in., the accelerator pedal may be depressed as specified by the manufacturer. If the accelerator is depressed, the manufacturer shall place foot flat on pedal and note the depression of the pedal.
- L40 BACK ANGLE - FRONT. The angle measured between a vertical line through the SgRP - front and the torso line. If the seatback is adjustable, use the normal driving and riding position specified by the manufacturer.
- L42 HIP ANGLE - FRONT. The angle measured between torso line and thigh centerline.
- L44 KNEE ANGLE - FRONT. The angle measured between thigh centerline and lower leg centerline measured on the right leg.
- L46 FOOT ANGLE - FRONT. The angle measured between the lower leg centerline and a line tangent to the ball and heel of the bare foot flesh line measured on the right leg. Ref SAE J826.
- L53 SgRP - FRONT TO HEEL. The dimension measured horizontally from the SgRP - front to the accelerator heel point.
- W3 SHOULDER ROOM - FRONT. The minimum dimension measured laterally between the trimmed surfaces on the "X" plane through the SgRP - front at height between the belt line and 254 mm (10.0 in.) above the SgRP - front, excluding the door assist strap and attaching parts.

- W5 HIP ROOM - FRONT. The minimum dimension measured laterally between the trimmed surfaces on the "X" plane through the SgRP - front within 25 mm (1.0 in.) below and 7 mm (3.0 in.) above the SgRP - front and 76 mm (3.0 in.) for and aft of the SgRP - front.
- W9 STEERING WHEEL MAXIMUM OUTSIDE DIAMETER. Define if other than round.
- H7 ACCELERATOR HEEL POINT TO THE STEERING WHEEL CENTER. The dimension measured vertically from the AHP - front to the intersection of the steering column centerline to a plane tangent to the upper surface of the steering wheel rim.
- H18 STEERING WHEEL ANGLE. The angle measured from vertical to the surface plane of the steering wheel.
- H30 SgRP - FRONT TO HEEL. The dimension measured vertically from the SgRP - front to the accelerator heel point.
- H50 UPPER BODY OPENING TO GROUND - FRONT. The dimension measured vertically from the trimmed body opening to the ground on the SgRP - front "X" plane.
- H61 EFFECTIVE HEAD ROOM - FRONT. The dimension measured along a line 8 deg. rear of vertical from the SgRP - front to the headlining plus 102 mm (4.0 in.).
- H67 FLOOR COVERING THICKNESS - UNDEPRESSED - FRONT. The dimension measured vertically from the surface of the undepressed floor covering to the underbody sheet metal at the accelerator heel point.

Rear Compartment Dimensions

- L41 BACK ANGLE - SECOND. The angle measured between vertical line through the SgRP - second and the torso line.
- L43 HIP ANGLE - SECOND. The angle measured between torso line and thigh centerline.
- L45 KNEE ANGLE - SECOND. The angle measured between thigh centerline and lower leg centerline.
- L47 FOOT ANGLE - SECOND. The angle measured between lower leg centerline and a line tangent to the ball and heel of the three-dimensional devices bare foot flesh line (Reference J826).
- L48 KNEE CLEARANCE - SECOND. The minimum dimension measured from the knee pivot center to the back of the front seatback minus 51 mm (2.0 in.).
- L50 SgRP COUPLE DISTANCE - SECOND. The dimension measured horizontally from the driver SgRP - front to the SgRP - second.
- L51 MINIMUM EFFECTIVE LEG ROOM - SECOND. The dimension measured along a line from the ankle pivot center to the SgRP - second plus 254 mm (10.0 in.).
- W4 SHOULDER ROOM - SECOND. The minimum dimension measured laterally between door or quarter trimmer surfaces on the "X" plane through the SgRP - second at height between 254-406 mm (10.0-16.0 in.) above the SgRP - second, excluding the door assist straps and attaching parts.
- W6 HIP ROOM - SECOND. Measured in the same manner as W5.
- H31 SgRP - SECOND TO HEEL. The dimension measured vertically from the SgRP - second to the two dimensional device heel point on the depressed floor covering.
- H51 UPPER BODY OPENING TO GROUND - SECOND. The dimension measured vertically from the trimmed body opening to the ground on the "X" plane 330 mm (13.0 in.) forward of the SgRP - second.
- H63 EFFECTIVE HEAD ROOM - SECOND. The dimension measured along a line 8 deg. rear of vertical from the SgRP to the headlining, plus 102 mm (4.0 in.).
- H73 FLOOR COVERING - DEPRESSED - SECOND. The dimension measured vertically from the heel point to the underbody sheet metal.

MVMA Specifications

METRIC (U.S. Customary)

Interior Vehicle And Body Dimensions – Key Sheet Dimensions Definitions

Luggage Compartment Dimensions

V1 USABLE LUGGAGE CAPACITY – Total of volumes of individual pieces of standard luggage set plus H-boxes stowed in the luggage compartment in accordance with the procedure described in paragraph 8.2 of SAE-J1100a.

Interior Volumes (EPA Classification)

The Interior Volume Index is listed for each body style except two seaters. The Interior Volume Index estimates the space in a car. It is based on four measurements – head room, shoulder room, hip room, and leg room – for the front and rear seats, plus trunk capacity.

The Trunk/Cargo Index is an estimate of the size of the trunk/cargo space. In station wagons and hatchbacks it is an estimate of the space behind the second seat.

Station Wagon / MPV – Third Seat Dimensions

- L85 SgRP COUPLE DISTANCE – THIRD. The dimension measured horizontally from the SgRP – second to the SgRP – third.
- L86 EFFECTIVE LEG ROOM – THIRD. The dimension measured along a line from the ankle pivot center to the SgRP – third plus 254 mm (10.0 in.).
- L87 KNEE CLEARANCE – THIRD. The minimum dimension from the knee pivot center to the back of second seatback minus a constant of 51 mm (2.0 in.). With rear-facing third seat, dimension is measured to closure.
- L88 BACK ANGLE – THIRD. Measured in the same manner as L41.
- L89 HIP ANGLE – THIRD. Measured in the same manner as L43.
- L90 KNEE ANGLE – THIRD. Measured in the same manner as L45.
- L91 FOOT ANGLE – THIRD. Measured in the same manner as L47.
- W85 SHOULDER ROOM – THIRD. Measured in the same manner as W4.
- W86 HIP ROOM – THIRD. Measured in the same manner as W5.
- H86 EFFECTIVE HEAD ROOM – THIRD. The dimension, measured along a line 8 deg. from the SgRP – third to the headlining rear of vertical plus a constant of 102 mm (4.0 in.).
- H87 SgRP – THIRD TO HEEL POINT.
- SD1 SEAT FACING DIRECTION – THIRD.

Station Wagon / MPV – Cargo Space Dimensions

- L200 CARGO LENGTH – OPEN – FRONT. The minimum dimension measured longitudinally from the back of the front seatback at the height of the undepressed floor covering to the rearmost point on the undepressed floor covering on the open tailgate or cargo surface if the rear closure is a conventional door type tailgate at the zero "Y" plane.
- L201 CARGO LENGTH – OPEN – SECOND. The dimension measured longitudinally from the back of the second seatback at the height of the undepressed floor covering to the rearmost point on the undepressed floor covering on the open tailgate or cargo floor surface if the rear closure is a conventional door type tailgate, at the zero "Y" plane.

- L202 CARGO LENGTH – CLOSED – FRONT. The minimum dimension measured horizontally from the back of the seat at the height of the undepressed floor covering to rearmost point on the undepressed floor covering on the closed tailgate or taildoor for station wagons, trucks and mpv's at the zero "Y" plane.
- L203 CARGO LENGTH – CLOSED – SECOND. The dimension measured horizontally from the back of the second seat at the height of the undepressed floor covering to the rearmost point on the undepressed floor covering on the closed tailgate or taildoor for station wagons, trucks and mpv's at the zero "Y" plane.
- L204 CARGO LENGTH AT BELT – FRONT. The minimum dimension measured horizontally from the back of the front seatback at the seatback top to the foremost normal surface of the closed tailgate or inside surface of the cap backdoor at the height of the belt, on the zero "Y" plane.
- L205 CARGO LENGTH AT BELT – SECOND. The minimum dimension measured horizontally from the back of the second seatback at the seatback top to the foremost normal surface of the closed tailgate at the height of the belt, on the zero "Y" plane.
- W201 CARGO WIDTH – WHEELHOUSE. The minimum dimension measured laterally between the trimmed wheelhousings floor level. For any vehicle not trimmed, measure to sheet metal.
- W203 REAR OPENING WIDTH AT FLOOR. The minimum dimension measured laterally between the limiting interferences of the rear opening at floor level.
- W204 REAR OPENING WIDTH AT BELT. The minimum dimension measured laterally between the limiting interferences of the rear opening at belt height or top of pick box.
- W205 REAR OPENING WIDTH ABOVE BELT. The minimum dimension measured laterally between the limiting interferences of the rear opening above the belt height.
- W500 CARGO WIDTH AT FLOOR. The maximum dimension measured laterally between the limiting interferences at floor level. This dimension shall include ribs and pillars, but will exclude wheelhouses.
- H197 FRONT SEATBACK TO LOAD FLOOR HEIGHT. The dimension measured vertically from the horizontal tangent to the top of the seatback to the undepressed floor covering at the rear wheel "X" coordinate on the zero "Y" plane.
- H201 CARGO HEIGHT. The dimension measured vertically from the top of the undepressed floor covering to the headlining at the rear wheel "X" coordinate on the zero "Y" plane.
- H202 REAR OPENING HEIGHT. The dimension measured vertically from the top of the undepressed floor covering to the upper trimmed opening on the zero "Y" plane with rear door fully open.
- H250 TAILGATE TO GROUND CURB MASS (WT.). The dimension measured vertically from the top of the undepressed floor covering on the lowered tailgate to ground on the zero "Y" plane.
- H505 MAXIMUM CARGO HEIGHT. The maximum vertical dimension rear of the front seat from the cargo floor to roof body or headlining at the zero "Y" plane.

MVMA Specifications

METRIC (U.S. Customary)

Interior Vehicle And Body Dimensions – Key Sheet Dimensions Definitions

- V2 STATION WAGON
Measured in inches:
$$\frac{W4 \times H201 \times L204}{1728} = \text{ft}^3$$

Measured in mm:
$$\frac{W4 \times H201 \times L204}{10^9} = \text{m}^3 \text{ (cubic meter)}$$
- V4 HIDDEN LUGGAGE CAPACITY – REAR OF FRONT SEAT.
The total volumes of individual pieces of one set of standard luggage stowed in any hidden cargo area below the load floor rear of the front seat.
- V5 TRUCKS AND MPV'S WITH OPEN AREA.
Measured in inches:
$$\frac{L506 \times W505 \times H503}{1728} = \text{ft}^3$$

Measured in mm:
$$\frac{L506 \times W505 \times H503}{10^9} = \text{m}^3 \text{ (cubic meter)}$$
- V6 TRUCKS AND MPV'S WITH CLOSED AREA.
Measured in inches:
$$\frac{L204 \times W500 \times H505}{1728} = \text{ft}^3$$

Measured in mm:
$$\frac{L204 \times W500 \times H505}{10^9} = \text{m}^3 \text{ (cubic meter)}$$
- V8 HIDDEN LUGGAGE CAPACITY – REAR OF SECOND SEAT.
The total volume of individual pieces of one set of standard luggage stowed in any hidden cargo area below the load floor rear of the second seat.
- V10 STATION WAGON CARGO VOLUME INDEX.
Measured in inches:
$$\frac{H201 \times L205 \times \frac{W4 + W201}{2}}{1728} = \text{ft}^3$$

Measured in mm:
$$\frac{H201 \times L205 \times \frac{W4 + W201}{2}}{10^9} = \text{m}^3 \text{ (cubic meter)}$$

Hatchback – Cargo Space Dimensions

All hatchback cargo dimensions are to be taken with the front seat in full down and rear position, and the rear seat folded down. The hatchback door is in the closed position. (For electronically adjusted seats, see the manufacturer's specifications for Design "H" Point).

- L208 CARGO LENGTH AT FRONT SEATBACK HEIGHT. The minimum horizontal dimension from the "X" plane tangent to the rearmost surface of the driver's seatback to the inside limiting interference of the hatchback door on the vehicle zero "Y" plane.
- L209 CARGO LENGTH AT FLOOR – FRONT. The minimum horizontal dimension measured at floor level from the rear of the front seatback to the normal limiting interference of the hatchback door on the vehicle zero "Y" plane.
- L210 CARGO LENGTH AT SECOND SEATBACK HEIGHT. The minimum dimension measured from the "X" plane tangent to the rearmost surface of second seatback or the load floor which is stowed at least one half of the H198 dimension height above the rear load floor, to the rearmost inside limiting interference on the zero "X" plane.
- L211 CARGO LENGTH AT FLOOR – SECOND SEATBACK. The minimum horizontal dimension measured at floor level from the rear of the second seatback or load floor panel to the normal limiting interference of the hatchback door on the vehicle zero "Y" plane.
- H197 FRONT SEATBACK TO LOAD HEIGHT. The dimension measured vertically from the horizontal tangent to the top of the seatback to the undepressed floor covering.
- H198 SECOND SEATBACK TO LOAD FLOOR HEIGHT: The dimension measured vertically from the second seatback to the undepressed floor covering.
- V3 HATCHBACK.
Measured in inches:
$$\frac{L208 + L209}{2} \times W4 \times H197$$

$$\frac{\hspace{10em}}{1728} = \text{ft}^3$$

Measured in mm:
$$\frac{L208 + L209}{2} \times W4 \times H197$$

$$\frac{\hspace{10em}}{10^9} = \text{m}^3 \text{ (cubic meter)}$$
- V4 HIDDEN LUGGAGE CAPACITY – REAR OF FRONT SEAT.
The total volumes of individual pieces of one set of standard luggage stowed in any hidden cargo area below the load floor rear of the front seat.
- V11 HATCHBACK CARGO VOLUME INDEX. Usable luggage (one (1) stand and luggage set) below floor:
Measured in inches:
$$\frac{L210 + L211}{2} \times W4 \times H198$$

$$\frac{\hspace{10em}}{1728} = \text{ft}^3$$

Measured in mm:
$$\frac{L210 + L211}{2} \times W4 \times H198$$

$$\frac{\hspace{10em}}{10^9} = \text{m}^3 \text{ (cubic meter)}$$

MVMA Specifications

METRIC (U.S. Customary)

Index

Subject	Page No.	Subject	Page No.
Alternator	16	Passenger Capacity	
Axle Drive, Front, Rear, All Four	2, 9, 10	Passenger Mass Distribution	
Axle Shafts	10	Pistons	
Battery	16	Power Brakes	
Body and Miscellaneous Information	17	Power, Engine	
Brakes - Parking Service	12, 13	Power Steering	
Camber	15	Power Teams	
Camshaft	3	Propeller Shaft	
Capacities		Pumps - Fuel	
Cooling System	5	Water	
Fuel Tank	6	Radiator - Cap, Hoses, Core	
Lubricants		Ratios - Axle, Transaxle	2, 9
Engine Crankcase	4	Compression	
Transmission / Transaxle	8, 9	Steering	
Rear Axle	10	Transmission / Transaxle	2, 8
Carburetor	2, 6	Rear Axle	2
Caster	15	Regulator - Alternator	
Climate Control System	19	Restraint System	
Clutch - Pedal Operated	8	Rims	
Coil, Ignition	16	Rods - Connecting	
Connecting Rods	4	Scrub Radius	
Convenience Equipment	20-21	Seats	
Cooling System	5	Shock Absorbers, Front & Rear	
Crankshaft	4	Spark Plugs	
Cylinders and Cylinder Head	3	Speedometer	
Diesel Information	4	Springs - Front & Rear Suspension	
Dimension Definitions		Stabilizer (Sway Bar) - Front & Rear	
Key Sheet - Exterior	28, 31, 32	Starting System	
Key Sheet - Interior	29, 30, 32, 33, 34	Steering	
Electrical System	15, 16	Suppression - Ignition, Radio	
Emission Controls	7	Suspension - Front & Rear	
Engine - General		Tail Pipe	
Bore, Stroke, Type	3	Theft Protection	
Compression Ratio	2	Thermostat, Cooling	
Displacement	2, 3	Tires	
Firing Order, Cylinder Numbering	3	Toe-In	
General Information, Power & Torque	2	Torque Converter	
Intake System	4	Torque - Engine	2, 8
Power Teams	2	Trailer Towing	2
Exhaust System	7	Transaxle	2
Equipment Availability, Convenience	20	Transmission - Types	2, 8
Fan, Cooling	5	Transmission - Automatic	2
Filters - Engine Oil, Fuel System	4	Transmission - Manual	2
Four Wheel Drive	10	Transmission - Ratios	2, 8
Frame	17	Tread	2
Front Suspension	11	Trunk Cargo Load	
Front Wheel Drive Unit	10	Trunk Luggage Capacity	2
Fuel Economy, EPA	1	Turning Diameter	3
Fuel Injection	6	Unitized Construction	1
Fuel System	6	Universal Joints, Propeller Shaft	1
Fuel Tank	6	Valve System	
Glass	18	Vehicle Dimensions	
Headlamps	18	Width	2
Headroom - Body	23, 24	Length	2
Heights	22	Height	2
Horns	15	Ground Clearance	2
Horsepower - Brake	2	Front Compartment	2
Ignition System	16	Rear Compartment	2
Inflation - Tires	13	Luggage Compartment	2
Interior Volumes	23	Station Wagon - Third Seat	2
Instruments	15	Station Wagon - Cargo Space	2
Lagroom	23, 24	Hatchback - Cargo Space	2
Lengths	22	Fiducial Marks	2
Leveling, Suspension	11	Voltage Regulator	16
Lifters, Valve	4	Water Pump	5
Linings - Clutch, Brake	8, 12	Weights	26, 27
Lubrication - Engine Transmission / Transaxle	4, 8, 9	Wheel Alignment	15
Luggage Compartment	23	Wheelbase	22
Models	1	Wheels & Tires	13
Motor Starting	16	Wheel Spindle	14
Muffler	7	Widths	22
Origin	1	Windshield	18
		Windshield Wiper and Washer	15

