

1996

IMPALA SS

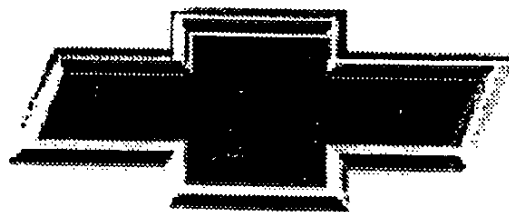

GENUINE CHEVROLET

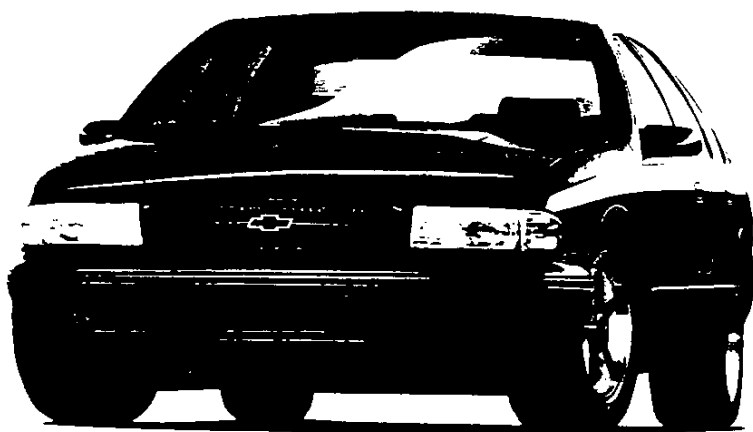

3





Dealer Order Guide

Caprice Classic Impala SS

Feature Availability

	CAPRICE SEDAN	CAPRICE WAGON	IMPALA SS
Air Bags — Driver and Front-Passenger	S	S	S
Air Conditioning — with R-134a Refrigerant	S	S	S
Antenna — Power	O	O	S
Brakes — 4-Wheel Anti-Lock (ABS)	S	S	S
Brake/Transmission Shift Interlock	S	S	S
Console — Full-Floor	NA	NA	S
Defogger — Rear-Window	O	O	S
Driver Seat — 6-Way Power	O	O	S
Door Locks — Child Security Rear	S	S	S
Engine — 4.3 Liter V8 with SFI	S	NA	NA
— 5.7 Liter V8 with SFI	O ¹	S	S
Exhaust System — Stainless-Steel	S	S	S
Exterior Accents — Body-Color	NA	NA	S
Exterior Trim — Blackout	NA	NA	S
Luggage Rack	NA	S	NA
Paint — Base-Coat/Clear-Coat	S	S	S
Remote Keyless Entry	O	NA	S
Scotchgard™ Fabric Protector	S	S	S
Speed Control — Electronic	O	O	S
Steering Column — Tilt-Wheel™ Adjustable	S	S	S
Stereo — AM/FM with Seek-Scan and Cassette Tape Player	S	S	S
— AM/FM with Seek-Scan and Compact Disc Player	O	O	O
Suspension — de Carbon Shocks	NA	NA	S
— Special Ride and Handling	NA	NA	S
Theft-Deterrent System — PASS-Key II	S	S	S
Tires — P215/75R-15 Whitewall Radials	S	NA	NA
— P225/75R-15 Whitewall Radials	NA	S	NA
— P235/70R-15 Blackwall Radials	O ²	NA	NA
— P235/70R-15 Whitewall Radials	O ²	NA	NA
— P225/50ZR-17 Blackwall	NA	NA	S
Trailer Package	NA	O	NA
Transmission — 4-Speed Electronically Controlled Automatic	S	S	S
Trunk — Power Opener	O	O	S
Wheels — 15" Aluminum with Locks	O	NA	NA
— 17" Aluminum with Locks	NA	NA	S
Wheel Covers — Deluxe	S	NA	NA
— Wire	O	S	NA
Wipers — Intermittent	S	S	S

S—Standard. O—Optional (some options may be available only as part of a Special Value Package.
See your Order Guide for feature availability). NA—Not available.
1—Requires Sport suspension. 2—Requires 5.7L engine.

Additional Information on Significant Features

- Both the Caprice and Impala SS have driver and front-passenger air bags as standard equipment. Air bags help to reduce the chance of injury in certain moderate to severe frontal collisions. Always wear safety belts, even with air bags.
- Both Impala and Caprice have PASS-Key II, a completely-passive theft-deterrent system that requires no activation or deactivation before leaving the vehicle. The system consists of a small, resistance-coded pellet located in the ignition key and a resistor measurement circuit in the steering column. If a key is inserted that doesn't have the correct resistance value, the fuel system and starter are temporarily disabled.

- Caprice and Impala SS have standard 4-wheel anti-lock brakes, which are designed to help minimize the possibility of wheel lockup, and result in better stability during severe braking. When wheel sensors detect an impending lockup, the control unit modulates brake pressure to the appropriate brake lines, helping to improve steering, even on slippery surfaces.

- Impala SS ride and handling characteristics are driving-enthusiast oriented, thanks to its standard Special Ride and Handling Suspension and de Carbon shocks, designed specifically to provide a firm, controlled ride.

- The 5.7 Liter LTI engine, standard on Impala SS, delivers 260 hp and 330 lb.-ft. of torque for outstanding acceleration and passing power.

Deletions

- Caprice: Two-Tone paint has been deleted.
- Caprice: Light Adriatic Blue Metallic and Purple Pearl Metallic have been deleted.
- Non-marketing cars have been deleted.

Chevrolet, the Chevrolet Emblem, Caprice and Impala are registered trademarks and the Impala Emblem is a trademark of the General Motors Corporation. Cadillac is a trademark of the GM Corp. PASS-Key is a registered trademark of the Radio Electronics Corporation. © 1995 General Motors Corp. All rights reserved. 96A-57c



Dealer Order Guide

Caprice Classic Impala SS

Feature Vehicle

Caprice Classic Sedan (1SC)

The Feature vehicle for 1996 is the Caprice Classic Sedan with Special Value Package 1SC, which includes:

- Power Windows and Trunk Opener
- Full-Size Spare
- Rear-Window Defogger
- P215/75R-15 W/S Tires
- Automatic Day/Night Rearview Mirror
- Dual Electric Remote, Heated Outside Rearview Mirrors
- Aluminum Wheels
- Visor — Right-Hand Covered Illuminated Mirror
- Rear-Compartment Reading Lamps
- Cornering Lamps
- Driver and Front-Passenger Power Seats
- Heat-Reflective Windshield
- Power Antenna
- Twilight Sentinel
- Remote Keyless Entry System
- Custom Interior Package
- AM/FM Stereo with Compact Disc Player.

The lead vehicle reinforcing the price/value relationship is the Caprice Classic with 1SA (see following for details).

Three Focus vehicles are featured, and each emphasizes a key-image attribute. They include:

- Value — 1SA
- Upscale (Leather) — 1SC
- Wagon — 1SD.

Please order accordingly.

Focus Vehicle

Caprice Classic Sedan (1SA)

Ordering Recommendations:

Recommended Caprice Classic Sedan content, based on national sales volume, is listed below to assist your dealership in ordering.

Caprice Classic Sedan with Special Value Package 1SA includes:

- 4.3 Liter Engine with 4-Speed Electronically Controlled Automatic Transmission
- Power Antenna, Windows and Trunk Opener
- Rear-Compartment Reading Lamps
- Automatic Day/Night Rearview Mirror
- Dual Electric Remote, Heated Outside Rearview Mirrors
- P215/75R-15 W/S Tires
- Deluxe Wheel Covers
- Full-Size Spare Tire
- Rear-Window Defogger.

Focus Vehicle

Caprice Classic Wagon (1SD)

Ordering Recommendations:

Recommended Caprice Classic — Wagon content, based on national sales volume, is listed below to assist your dealership in ordering.

Caprice Classic — Wagon 1SD includes:

- 5.7 Liter V8 Engine with 4-Speed Electronically Controlled Automatic Transmission
- Power Antenna and Windows
- Dual Electric Remote Outside Mirrors
- Wire Wheel Covers
- Full-Size Spare Tire
- Rear-Window Defogger
- Driver and Front-Passenger Power Seats
- Deluxe Rear Compartment
- Rear-Compartment Reading Lamps
- Automatic Leveling Suspension
- Custom Interior Package
- Automatic Day/Night Rearview Inside Mirror with Dual Reading Lamps
- Visor — Right-Hand Covered Illuminated Mirror
- Rear-Compartment Security Cover
- Heat-Reflective Windshield.

Feature/Focus Vehicle

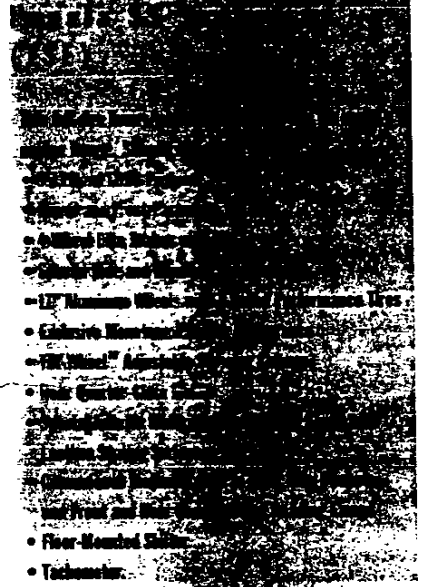

Positioning Statement

Caprice is positioned as the full-size sedan that appeals to the mature, domestic buyer who puts a priority on safety, size and ride characteristics. This includes families and retirees looking for the advantages of a big car at an affordable price.

Impala SS appeals to driving enthusiasts who appreciate the performance potential of a V8 engine in a full-size sports sedan. The typical Impala SS buyer is a married male who is domestically committed and seeks a power/performance image in the car he drives.

Competitive Vehicles

- | | |
|-------------------------|--------------------|
| • Caprice: | • Impala SS: |
| • Ford Crown Victoria | • Chrysler LHS |
| • Mercury Grand Marquis | • Ford Taurus SHO. |
| • Chrysler New Yorker. | |

NOTE: Model, PEG and optional content may vary in your locality. Use the Retail Sales Analysis (RSA) to verify or select your dealership's focus vehicle content.

96

Dealer Order Guide

Caprice Classic Impala SS

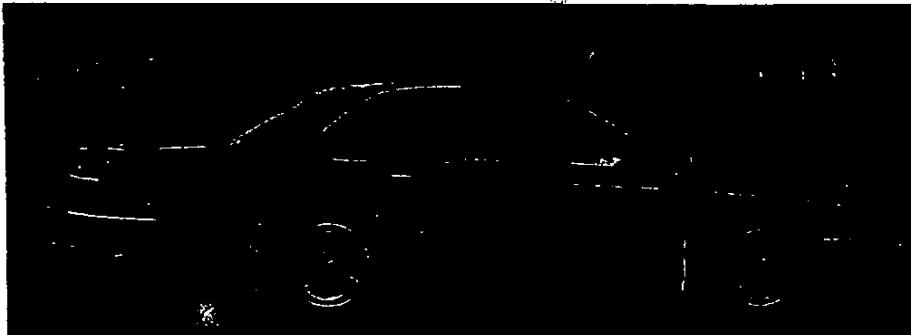

Feature Vehicle

for 1996 is the Caprice Classic Sedan with Special Value Package (ISC) (detailed on the following sheet).

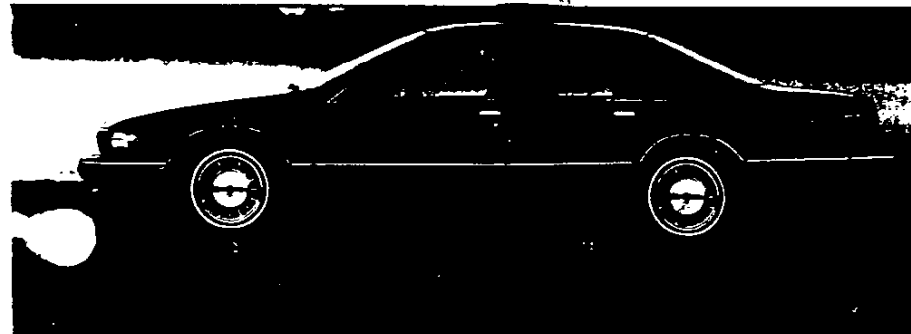

Focus Vehicle

for 1996 is the Caprice Classic Sedan with Special Value Package (ISA). This model represents the best opportunity for high-volume Caprice sales at your dealership (detailed on the following sheet).



Feature/Focus Vehicle

for 1996 is the Impala SS Sedan. This full-size sport sedan boasts eye-catching style, superb performance and accommodations for five to attract the true enthusiast.



S.P.A.C.E.™ BLUE = New '96 feature.

SAFETY AND SECURITY

S

- DRIVER AND FRONT-PASSENGER AIR BAGS — help reduce the chance of injury in certain moderate to severe frontal collisions. Always wear safety belts, even with air bags.
- 4-WHEEL ANTI-LOCK BRAKE SYSTEM (ABS) — helps reduce wheel lockup and helps driver maintain steering control during severe braking, even on slippery surfaces.
- PASS-KEY II THEFT-DETERRENT SYSTEM — consists of a small, resistance-coded pellet in the ignition key which must match a measurement circuit in the steering column to enable the engine to start.
- CHILD SECURITY REAR-DOOR LOCKS — provide security against a child opening rear doors from the inside.
- BRAKE/TRANSMISSION SHIFT INTERLOCK (BTSI) — prevents transmission from being shifted out of Park without first applying the brake.
- STEEL SAFETY CAGE — surrounds the entire passenger compartment. Caprice meets 1997 Federal side-impact standards today.

PERFORMANCE

P

- CAPRICE: 4.3 LITER V8 ENGINE WITH SEQUENTIAL-PORT FUEL INJECTION — delivers 200 hp and 235 lb.-ft. of torque for smooth, responsive performance.
- 5.7 LITER V8 ENGINE WITH SEQUENTIAL-PORT FUEL INJECTION (OPTIONAL ON CAPRICE, STANDARD ON IMPALA SS) — uses innovative Corvette technology for truly impressive performance. Horsepower is 260 at 4800 rpm.
- FOUR-SPEED ELECTRONICALLY CONTROLLED AUTOMATIC TRANSMISSION (FLOOR-MOUNTED SHIFTER ON IMPALA SS) — provides virtually seamless performance with almost imperceptible shifts.
- CAPRICE: P215/75R-15 W/S TIRES — all-season, steel-belted tires provide excellent traction (P225/75R-15 W/S on Wagon).
- IMPALA SS: P255/50ZR-17 B/W TIRES — Z-rated performance tires deliver a compliant ride and responsive handling.
- TACHOMETER — provides an accurate RPM measurement (Impala SS).

APPEARANCE

A

- CAPRICE: WIDE BODY-SIDE MOLDINGS — added styling accents help prevent door dings.
- IMPALA SS: BODY-COLOR FRONT AND REAR FASCIAE, WHEEL-OPENING MOLDINGS — provide enthusiast-oriented monochromatic appearance.
- BASE-COAT/CLEAR-COAT PAINT — resists fading and provides high-gloss shine for long-lasting exterior beauty.
- TINTED, FLUSH-MOUNTED GLASS — reduces UV rays, improves aerodynamics and reduces wind noise while providing bold appearance.

COMFORT AND CONVENIENCE

C

- OPTIONAL POWER WINDOWS WITH DRIVER'S EXPRESS-DOWN FEATURE (STANDARD ON IMPALA SS) — allows easy operation of all windows with one-touch operation to lower driver window.
- AM/FM ELECTRONICALLY TUNED STEREO — includes seek-scan features and provides high-quality sound through premium front and rear coaxial speakers (UNO).
- OPTIONAL REMOTE POWER TRUNK RELEASE (STANDARD ON IMPALA SS) — allows trunk lid to be opened from inside the vehicle.

EASY-TO-OWN

E

- TWO-SIDE-GALVANIZED STEEL — on all exterior body panels (except the roof) for excellent protection against corrosion.
- SCOTCHGARD™ FABRIC PROTECTOR — on seats, door panels, floor covering; resists stains and makes cleanup easy.
- STAINLESS-STEEL EXHAUST SYSTEM — includes all pipes, catalytic converter and muffler to resist corrosion.
- AIR CONDITIONING WITH R-134a REFRIGERANT — quickly cools interior for occupant comfort.
- GENUINE CUSTOMER CARE — a no-deductible, 3-year/36,000-mile limited warranty, 24-hour roadside assistance via toll-free hot line, and courtesy transportation, if your vehicle ever needs warranty work, at participating dealers.

Trim Color/Seat Style Availability



Custom Cloth available in Medium Beige, Medium Blue, Gray and Ruby.



Caprice: Standard Custom Cloth SS/45 seat with center front armrest, adjustable head restraints, driver- and passenger-seat recliners and seat-back pocket.



Leather available in Medium Beige, Medium Blue, Gray and Ruby.



Caprice: Leather SS/45 with center pull-down armrest, adjustable head restraints, driver- and passenger-seat recliners and rear-seat center armrest.



Impala Leather available in Gray.

Impala: Gray Leather 45/45 Sport bucket seat with full-floor console and cup holders, adjustable head restraints, driver- and passenger-seat recliners and seat-back pockets.



Wheels

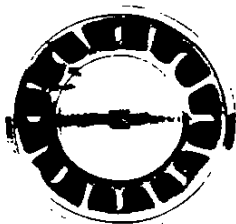

Caprice Classic Sedan standard 15" deluxe wheel cover.

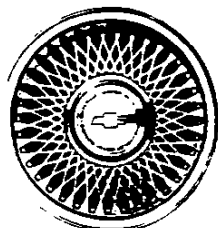

Caprice Classic Sedan optional 15" aluminum wheel (NA on Wagon).

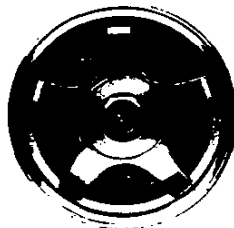

Impala SS standard 17" aluminum wheels.

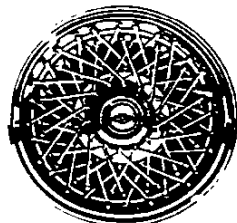

Caprice Classic Wagon standard 15" wire wheel cover (optional on Sedan).

Most Popular Retail Exterior Colors by Percentage

Below are the associated four most popular Caprice colors for 1996, based on national sales volume. They are listed for reference only. To identify the top-selling colors in your area, by model, use the Retail Sales Analysis (RSA).

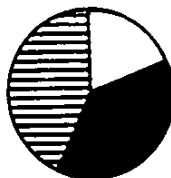

Bright White	19%
Light Driftwood Metallic	15%
Dark Cherry Metallic	12%
Dark Green-Gray Metallic	11%
Other colors	43%

Most Popular Retail Exterior Colors with Corresponding Interior Color Availability

Caprice Classic

Interior Colors

Medium Beige Medium Blue Gray Ruby

Exterior Colors

Bright White	■	■	■	■
Dark Cherry Metallic	■		■	■
Dark Green-Gray Metallic	■		■	
Light Driftwood Metallic	■			

Impala SS

Interior Colors

Gray

Exterior Colors

Black	■
Granite Metallic	■
Dark Cherry Metallic	■

Buyer Demographics

- Caprice Classic:
 - Median age of buyer is 67 years.
 - Median income of \$35,000 annually.
 - 63% of Caprice Classic buyers are male.
 - 75% of Caprice Classic buyers are retired.
- Impala SS:
 - Median age of buyer is 40-60 years.
 - Median income of \$60,000 annually.
 - 80% of Impala SS buyers are male.
 - 50% of Impala SS buyers are retired.

IMPALA SS

REVISED:1-29-96

1996 ORDER GUIDE

CAPRICE
Page 1

Prices Shown Are Manufacturer's Suggested Retail Prices (MSRP) At The Time Of Publication. These Prices Are To Be Used Only As An Aid To Inventory Management Since MSRP Figures Change Periodically. The Vehicle Price Schedule Is The Official Pricing Documentation Of Chevrolet Motor Division And Should Be Used In Discussing Vehicle Prices With Potential Buyers. The Model Prices Shown In The Order Guide Include The Destination Freight Charges.

IMPALA SS EQUIPMENT SUMMARY

1BL19

STANDARD INTERIOR FEATURES

AIR CONDITIONING:		S
CARGO NET:	LUGGAGE AREA	S
DEFOGGER:	REAR WINDOW, W/HEATED OUTSIDE REARVIEW MIRRORS	S
GAGES:	OIL CHANGE MONITOR, OIL PRESSURE, TRIP ODOMETER, VOLTMETER AND TACHOMETER	S
GLASS:	TINTED	S
KEYLESS ENTRY:	REMOTE	S
LIGHTING:	COURTESY, FRONT DOOR LAMPS READING LAMPS, DUAL-IN REARVIEW MIRROR AND REAR COMPARTMENT	S
LOCKS:	CHILD SECURITY, REAR POWER	S
MIRROR:	INSIDE REARVIEW, W/DUAL READING LAMPS	S
MONITOR:	OIL CHANGE	S
RADIO:	ELECTRONICALLY TUNED AM/FM STEREO RADIO W/SEEK-SCAN, DIGITAL CLOCK, W/AUTOMATIC TONE CONTROL, CASSETTE TAPE, THEFT LOCK AND SPEED COMPENSATED VOLUME (INCLUDES PREMIUM FRONT AND REAR COAXIAL SPEAKERS)	S
RESTRAINT SYSTEM:	DRIVER AND PASSENGER SIDE AIR BAGS	S
SCOTCHGARD:	FABRIC PROTECTOR INCLUDES FLOOR COVERING AND MATS	S
SPEED CONTROL:	ELECTRONIC	S
TRUNK RELEASE:	POWER	S
WARNING LIGHTS:	LOW FLUID LOW OIL LEVEL	S
WINDOWS:	POWER WITH DRIVER'S SIDE EXPRESS DOWN	S

STANDARD EXTERIOR FEATURES

ANTENNA:	POWER, WITH BLACK BASE	S
DOOR HANDLES:	BODY COLOR	S
EMBLEMS:	BODY SIDE AND REAR DECK LID EMBLEMS	S
FACIAS:	BODY COLOR FRONT AND REAR	S
LOCK CYLINDER:	BLACK KEY LOCK CYLINDER	S
PAINT:	BASE COAT/CLEAR COAT	S
PASS KEY:	THEFT DETERRENT SYSTEM	S
SPOILER:	REAR	S
TIRES:	FULL SIZE SPARE P255/50ZR-17 BLACKWALL	S
WIPERS:	WINDSHIELD INTERMITTENT	S

STANDARD CHASSIS FEATURES

AXLE:	REAR, 3.08 LIMITED SLIP DIFFERENTIAL	S
BRAKES:	4-WHEEL DISC ANTI-LOCK BRAKE/TRANSMISSION SHIFT INTERLOCK	S
COOLING:	EXTRA CAPACITY TRANSMISSION OIL COOLER	S
ENGINE:	5.7 LITER V8 SFI	S
EXHAUST SYSTEM:	STAINLESS STEEL	S
FUEL TANK:	23 GALLON CAPACITY	S
SHOCKS:	DeCARBON	S
SUSPENSION:	SPECIAL RIDE AND HANDLING	S
TRANSMISSION:	4-SPEED AUTOMATIC ELECTRONICALLY CONTROLLED	S

CAPRICE

1996 ORDER GUIDE

REVISED: 1-29-96

Page 2

Prices Shown Are Manufacturer's Suggested Retail Prices (MSRP) At The Time Of Publication. These Prices Are To Be Used Only As An Aid To Inventory Management Since MSRP Figures Change Periodically. The Vehicle Price Schedule Is The Official Pricing Documentation Of Chevrolet Motor Division And Should Be Used In Discussing Vehicle Prices With Potential Buyers. Prices Shown In The Order Guide Include The Destination Freight Charges.

**IMPALA SS
TRIM DEFINITION & OPTION SUMMARY**

INTERIOR TRIM

1BL19

CONSOLE:	FULL FLOOR SHIFTER WITH CUPHOLDERS	S
FLOOR COVERING:	MATS, FRONT/REAR FLOOR, CARPETED, COLOR-KEYED	S
INTERIOR FINISH:	BLACK SATIN FINISH REPLACES WOODGRAIN	S
MAP POCKETS:	IN DOOR	S
MIRRORS:	VISOR, LH AND RH COVERED	S
SEAT FRONT:	POWER, DRIVER SIDE	S
SEAT TRIM:	LEATHER 45/55 SEAT WITH ADJUSTABLE HEAD RESTRAINTS, DRIVER AND PASSENGER RECLINING SEATS AND SEAT BACK POCKETS WITH POWER 6-WAY ADJUSTER (DRIVER SIDE)	S
STEERING WHEEL:	ADJUSTABLE STEERING COLUMN, TILT WHEEL	S

EXTERIOR TRIM

GRILLE:	BODY COLOR	
MIRRORS:	TWIN REMOTE ELECTRIC	S
MOLDINGS:	BLACK TAIL LAMP	S
	BODY COLOR ROCKER MOLDINGS	S
	BODY COLOR WHEEL OPENING MOLDINGS	S
	NARROW BODY SIDE	S
	REAR QUARTER GLASS MOLDING	S
WHEELS:	17" ALUMINUM	S

IMPALA SS SEDAN

24,995.00 **Model 1BL19 IMPALA SS**
 * Includes Destination and Handling Charges

MUST SPECIFY: EMISSION, ENGINE, TRANSMISSION
MUST ORDER ONE GROUP -- NO DELETIONS ALLOWED

N.C.	Base Preferred Equipment Group (Refer Standard Equipment Summary Page)	1SF	1SE
		x	x
490.00	Preferred Equipment Group 1 Mirror, Rearview Auto Day/Night Mirror, RH Visor, Illuminated Power Seat: Passenger 6-Way Adjuster Twilight Sentinel		x x x x

COLOR AND TRIM SELECTION

Interior Trim Color		Gray	
MODEL	SEAT TYPE	SEAT OPTION*	
1BL19	Leather 45/45	AS7	143

*Seat Option AS7 Must Be Specified

SOLID PAINT APPLICATION

Exterior Paint Color	Color Code	Gray
Black	41U	x
Cherry, Dk (Met)	77U	x
Green-Gray, Dk (Met)	18U	x

POWER TEAMS

ENGINE OPTION CONDITION	AXLE RATIO
-	3.08
LT1 MX0	Std

ADDITIONAL OPTIONS

ACKNOWLEDGEMENTS

- RBS Multiple Order Numbers
- R8T Preliminary Invoice
- VK3 **BRACKET:** License Plate, Front

EMISSIONS

- FE9 Federal Emission Requirement
- NG1 Massachusetts/NY Emission Requirement
- YF5 California Emission Requirement
- NB8 California/MA Emission Override (Reqs FE9 Emission)
- NC7 Federal Emission Override (Reqs YF5/NG1 Emission)

- K05 **HEATER:** Engine Block

MIRRORS:

- DF6 Rearview, Auto Day/Night (Incl w/1SE)
- D64 Visor, RH Illuminated (Incl w/1SE)

RADIO EQUIPMENT

- UNO Electronically Tuned AM/FM Stereo Radio w/Automatic Tone Control, Compact Disc Player, Digital Clock, Theft Lock and Speed Compensated Volume (Incls Premium Front and Rear Coaxial Speakers)

- A23 **WINDSHIELD:** Heat Reflective

5.7L V8

LT1

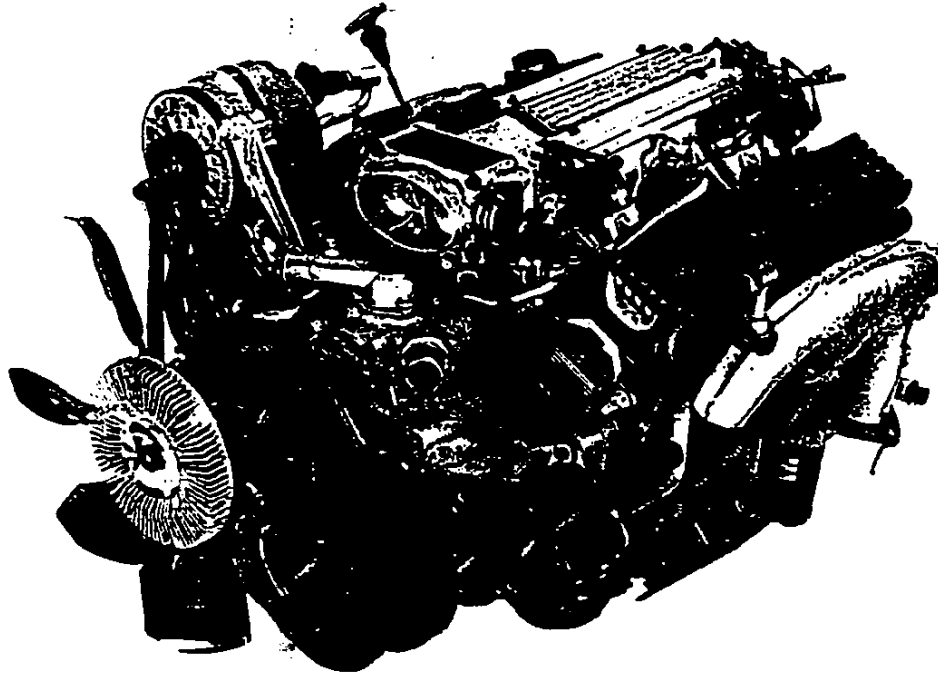

B & D Trailing Version Shown



"The LT1 V8 provides the kind of low-speed punch and strong throttle response that can't be matched by import rivals with their high-strung fours and V6's. It also produces a menacing growl that is music to the ears of many car aficionados."

Consumer Guide

Product Specifications

Type:
5.7L V8

Displacement:
350 CID (5733 cc)

Compression Ratio:
10.4:1 (F, Y)
10.0:1 (B, D)

Valve Configuration:
OVERHEAD VALVES

Manufactured:
FLINT, MI

Valve Lifters:
HYDRAULIC ROLLER

Firing Order:
1-8-4-3-6-5-7-2

Bore x Stroke:
4.00 x 3.48 in. (101.60 x 88.39 mm)

Fuel System:
SEQUENTIAL PORT
FUEL INJECTION

Horsepower:
300 @ 5000 rpm (Y)
280 @ 5000 rpm (F)
260 @ 5000 rpm (B, D)

lb-ft Torque:
335 @ 4000 rpm (Y)
325 @ 2400 rpm (F)
330 @ 2400 rpm (B & D)

Maximum Engine Speed:
6000 rpm (F, Y)
5500 rpm (B, D)

Emissions Control:

- EVAPORATIVE
- CATALYTIC CONVERTER
- EXHAUST GAS RECIRCULATION (EGR)
- POSITIVE CRANKCASE VENTILATION (PCV)
- AIR INJECTION REACTION (AIR)

Materials

Block:
CAST IRON

Cylinder Head:
CAST ALUMINUM (F, Y)
CAST IRON (B, D)

Intake Manifold:
CAST ALUMINUM

Exhaust Manifold:
CAST IRON

Main Bearing Caps:
CAST IRON

Crankshaft:
CAST IRON (B,D,F)
FORGED STEEL (Y)

Camshaft:
STEEL

Connecting Rods:
POWDERED METAL

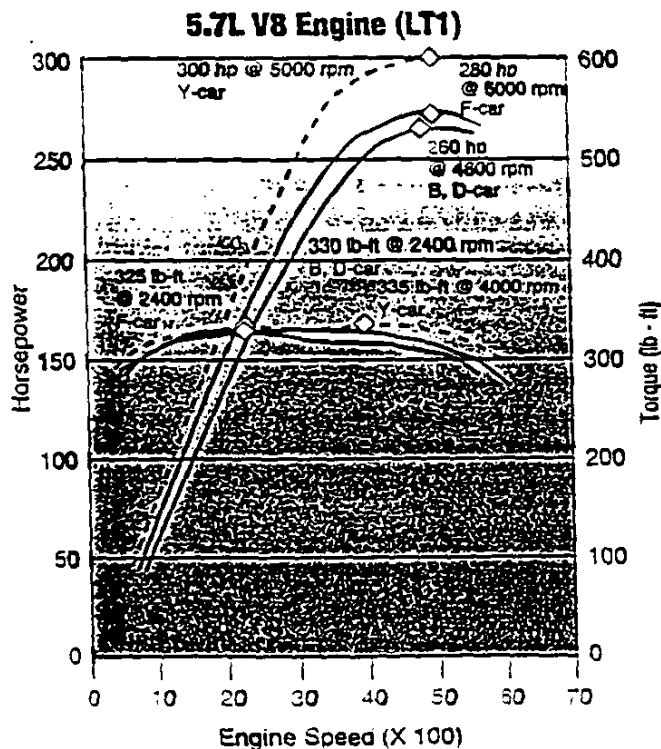

Applications:

Chevrolet Caprice - option
Buick Roadmaster - base
Cadillac Fleetwood - base
Chevrolet Camaro - option
Pontiac Firebird - option
Chevrolet Corvette - base

Information may vary with application. All specifications listed are based on the latest product information available at the time of publication. The right is reserved to make changes at any time without notice.

5.7L V8

LT1

Features and Benefits

Sequential-port fuel injection - The 5.7L V8 features sequential port fuel injection (SFI), the most sophisticated and advanced fuel delivery technology Powertrain offers. This is a very precise fuel delivery system in which the powertrain control module (PCM) individually controls the fuel injectors. With SFI, each of the eight injectors are fired one at a time, in a sequence that matches the firing order, further improving fuel timing for optimum combustion. SFI offers greater emissions control, idle stability, performance, durability, fuel efficiency and driveability.



On-Board Diagnostics Second Generation (OBDII) - As with all GM vehicles, the LT1 will be fully OBDII compliant in 1996. The PCM, a highly sophisticated on-board computer and one of the industry's most powerful, must now monitor a wide variety of emissions systems and components for the slightest level of deterioration or malfunction. This includes the fuel delivery system, catalytic converter and EGR valve. Its diagnostic tools include the oxygen sensor, crank position sensor, MAP sensor and manifold air temperature sensor. These systems have secondary benefits as well. Rear oxygen sensors, for example, help improve fuel control and overall performance. In addition to ensuring vehicles meet the more stringent emissions standards and improving overall system reliability, OBDII has some benefits for the customer. The PCM stores and retrieves even more diagnostic messages to help technicians diagnose and fix problems more quickly and accurately. And since OBDII sets trouble codes (SERVICE ENGINE SOON light), when a system begins to deteriorate rather than waiting for a complete system failure, drivers can bring their vehicles in for service before experiencing a possible break down or more costly repair.

Powertrain control module - Coupled with SFI, the LT1's powertrain control module (PCM) controls the individual fuel injectors and optical ignition system, and interacts with the electronically controlled transmission.



Ignition system - The LT1's powerful ignition system has been enhanced for 1996. Customers will notice improved idle quality thanks to new low-resistance wires and new spark plugs. This high current, low resistance system offers cold-start performance unsurpassed by today's competition. Even in temperatures as cold as 20 degrees below zero, the LT1 starts every time within six-tenths of one second.

The legend lives on - This legendary small-block V8 packs enormous power and responsiveness into an efficient package. The engine — a radical re-design of GM's historical 350 CID V8 — represents the future of General Motors overhead valve (OHV) engines. RPM range is increased 800 to 1000 revs beyond most OHV engines, giving the LT1 the low-end punch of an OHV and the high-speed responsiveness of an overhead cam engine. This "best of both worlds" characteristic of the LT1 makes it perfect for sport performance models.

There's more than just brawn - Power isn't the only attribute of the LT1. It leads the entire spectrum of engine attributes with an unrivaled degree of balanced excellence. Fuel efficiency, strict emissions compliance, system durability, performance and attention to hardware detail add up to one great engine.

Opti-spark - The LT1 features an angle-based opti-spark system — the highest precision spark control and delivery system available. That's because it reads cylinder positions at every degree of crank rotation, enabling spark-control adjustments to be accomplished several times each second.



Exhaust manifold - The LT1's exhaust manifold has single-point air injection and an electric air pump, thereby eliminating unnecessary parasitic loss experienced with mechanical systems. This extremely quiet air pump is especially helpful during cold starts for better catalytic converter efficiency. New for 1996, the exhaust manifold will feature tri-layered stainless steel gaskets. This improves the durability of the gaskets over time and helps the system meet GM's exhaust leakage specifications. The F-car's exhaust manifold and converters help it to meet the strict California emissions standards — the toughest in the country. In fact, every F-car produced contains all the technologies needed to pass California emissions requirements, making it truly a "50-state car."



Copper lead bearings — New for '96, the LT1 will feature copper lead cam bearings. The copper replaces the former cadmium lead bearings. This removes the environmentally unfriendly material from the manufacturing site, as well as enables the copper to be recycled.

Other key features - The 5.7L V8 LT1 offers many distinctive features that have earned it a clear market niche. This includes a gear-driven water pump that helps ensure coolant flow, even in the event of accessory belt breakage. Dual-oxygen sensors and knock sensors, coupled with accurate Multec fuel injectors and opti-spark, provide optimum control for each cylinder bank. LT1 also features powdered-metal connecting rods and positively ventilated angle-based ignition timing for improved reliability.



Continuous improvement - Throughout its life, the LT1 has received improvements in reliability and serviceability, such as an upgraded oil pan, oil-level sensor, coolant pump and single-speed electric fuel pump. In the spirit of continuous improvement, new composite rocker arm covers were added to absorb more engine noise and vibration. Camshaft profile modifications offered last year on the B and D platforms for improved performance and noise reduction will be rolled out for F and Y platforms in 1996. The Y-car application will also receive a 5-degree throttle (offered in 1994 on the F-car) for improved launch feel and smoother transitions off the line. The pistons in the LT1 have been modified for 1996, and feature a positive twist top ring design. This improves the seal between piston and cylinder bore, and reduces blow-by emissions, particularly at high engine speeds. The LT1 engine will also use long life coolant.

Range extension - The range extension of the LT1 has raised the level of competition for all large displacement sport and passenger car engines because it delivers the character that all customers want. Its design integrity is evidenced by the outstanding customer response we have had since its introduction. The LT1 has power at a broad range of engine speeds, a lively, responsive throttle and outstanding fuel efficiency.

Horsepower and torque - The 5.7L V8 LT1 offers horsepower and torque ratings for four vehicle platforms — the Y, F, B and D. In the Y-car, the LT1 is rated at 300 horsepower at 5000 rpm and 335 lb - ft of torque at 4000 rpm. Applied to the F-car, the LT1 rates 280 hp at 5000 rpm and 325 lb - ft of torque at 2400 rpm. The B and D car ratings are 260 hp at 5000 rpm and 330 lb - ft of torque at 2400 rpm.

MANUFACTURERS MOTOR VEHICLE SPECIFICATIONS

METRIC (U.S. CUSTOMARY)

1996

Manufacturer CHEVROLET MOTOR DIVISION GENERAL MOTORS CORPORATION	Vehicle Line IMPALA SS SEDAN	
Mailing Address 30007 VAN DYKE WARREN, MI 48090-9065	Issued	Revised

Direct questions concerning these specifications to the manufacturer listed above.

The information contained herein is prepared, distributed by, and is solely the responsibility of the vehicle manufacturing company to whose products it relates. This specification form was developed by the vehicle manufacturing companies under the auspices of the American Automobile Manufacturers Association.

The General Specifications herein are those in effect at date of compilation and are subject to change without notice or incurring obligation by the manufacturer.

AAMA

American Automobile Manufacturers Association

Blank Forms Provided by Technical Affairs Division

FORM AAMA-96

Table of Contents

	1	Vehicle Models/Origin	∅	Indicates Format Change
	2	Power Teams		From Previous Year
	3	Engine		
	4	Lubrication System		
	4	Diesel System		
	5	Cooling System		
	6	Fuel System		
	7	Vehicle Emission Control		
∅	7	Exhaust System		
	8-10	Transmission, Axles and Shafts		
	11	Suspension		
	12-13	Brakes, Tires and Wheels		
	14	Steering		
	15-16	Electrical		
	17	Body - Miscellaneous Information		
	17	Frame		
	18	Restraint System		
	18	Glass		
	18	Headlamps		
	19	Climate Control System		
∅	20-21	Convenience Equipment		
	21	Trailer Towing		
	22-24	Vehicle Dimensions		
	25	Vehicle Fiducial Marks		
	26	Vehicle Mass		
	27	Optional Equipment Differential Mass (Weight)		
	28-34	Vehicle Dimensions Definitions - Key Sheets		
	35	Index		

NOTE:

1. This form uses both SI Metric units and U.S. Customary units. The metric unit of measure is presented first, and the U.S. Customary unit follows in parentheses.
2. UNLESS OTHERWISE INDICATED:
 - a. Specifications apply to standard models without optional equipment. Significant deviations are noted.
 - b. Nominal design dimensions are used throughout these specifications.
 - c. All linear dimensions are in millimeters (inches), and all mass (weight) specifications are in kilograms (pounds).
3. The General Specifications herein are those in effect at date of compilation and are subject to change without notice or incurring obligation by the manufacturer.
4. Additional Vehicle Dimensions (based in part on SAE J1100 "Motor Vehicle Dimensions") may be available from the manufacturer.

MVMA Specifications

Vehicle Line IMPALA SS SEDAN
 Model Year 1996 Issued _____ Revised (#) _____

METRIC (U.S. Customary)

Vehicle Origin

Design & development (company)	Midsized Car Division
Where built (country)	U.S.A.
Authorized U.S. sales marketing representative	Chevrolet Motor Division

Vehicle Models

Model Description & Drive (FWD / RWD / AWD / 4WD)*	Introduction Date	Make, Vehicle Models, Series, Body Type (Mfg's Model Code)	No. of Designated Seating Positions (Front / Rear)	Max. Trunk/Cargo Load-Kilograms (Pounds)	EPA Fuel Economy (City/Hwy)
IMPALA SS 4-Dr. Notchback Sedan (RWD)		1BL19 (w/WX3)	5 (2/3)	92.4 (203.6)	17/26

* FWD - Front Wheel Drive RWD - Rear Wheel Drive AWD - All Wheel Drive 4WD - Four Wheel Drive

MVMA Specifications

Vehicle Line IMPALA SS SEDAN
 Model Year 1996 Issued _____ Revised (e) _____

METRIC (U.S. Customary)

Engine Description
 Engine Code

5.7 LITER V8 (350 CID)
 SEQUENTIAL FUEL INJECTION RPO LT1

Engine - General

Type & description (inline, V, angle, flat, location, front, mid, rear, transverse, longitudinal, sohc, dohc, ohv, hemi, wedge, pre-chamber, etc.)	90 Deg. V Front Longitudinal	
Manufacturer	General Motors Powertrain Division	
No. of cylinders	8	
Bore	101.6 mm (4.0 in.)	
Stroke	86.40 mm (3.48 in.)	
Bore Spacing (C / L to C / L)	111.8 mm (4.40 in.)	
Cylinder block material & mass kg. (lbs.) (machined)	Cast Iron	
Cylinder block deck height	229.4 mm (9.025 in.)	
Cylinder block length	506.2 mm (19.93 in.)	
Deck clearance (minimum) (above or below block)	.025 Below	
Cylinder head material & mass kg. (lbs.)	Cast Iron	
Cylinder head volume cm ³ (inches ³)		
Cylinder liner material	Not Applicable	
Head gasket thickness (compressed)	1.245 mm (0.049 in.)	
Minimum combustion chamber total volume cm ³ (inches ³)		
Cyl. no. system (front to rear)*	L. Bank	1-3-5-7
	R. Bank	2-4-6-8
Firing order	1-8-4-3-6-5-7-2	
Intake manifold material & mass kg. (lbs.)**	Cast Aluminum	
Exhaust manifold material & mass kg. (lbs.)**	Cast Iron	
Knock sensor (number & location)	2 - One Each Side of Cylinder Case	
Fuel required unleaded, diesel, etc.	Unleaded	
Fuel antiknock index (R + M) + 2		
Engine Mounts	Quantity	2
	Material and type (elastomeric, hydroelastic, hydraulic damper, etc.)	Elastomeric
	Added isolation (sub-frame, crossmember, etc.)	Not Applicable
Total dressed engine mass (wt) dry***	273.24 kg. (602.4 lbs.)	

Engine - Pistons

Material & mass, g (weight, oz.) - piston only	Cast Aluminum
--	---------------

Engine - Camshaft

Location	In Cylinder Block "V" Above Crankshaft	
Material & mass kg (weight, lbs.)	Steel	
Drive type	Chain / belt	Chain
	Width / pitch	

* Rear of engine - drive takeoff. View from drive takeoff end to determine left & right side of engine.

** Finished state.

*** Dressed engine mass (weight) includes the following: All those items necessary to make the engine a complete ready-to-run unit.

MVMA Specifications

Vehicle Line IMPALA SS SEDAN
 Model Year 1996 Issued _____ Revised (●) _____

METRIC (U.S. Customary)*

Engine Description	5.7 LITER V8 (350 CID)
Engine Code	SEQUENTIAL FUEL INJECTION RPO LT1

Engine - Valve System

Hydraulic lifters (std., opt., n.a.)	Standard	
Valves	Number intake / exhaust	8/8
	Head O.D. intake / exhaust	49.28 mm (1.94 in.) / 38.1 mm (1.50 in.)

Engine - Connecting Rods

Material & mass kg., (weight, lbs.)*	Steel
Length (axes CA. to CA.)	144.78 mm (5.70 in.)

Engine - Crankshaft

Material & mass kg., (weight, lbs.)*	Cast Iron	
End thrust taken by bearing (no.)	5	
Length & number of main bearings	5	
Seal (material, one, two piece design, etc.)	Front	Fluroelastomer/One Piece Lip Seal
	Rear	Fluroelastomer/One Piece Lip Seal

Engine - Lubrication System

Normal oil pressure kPa (psi) at engine rpm	41 (6) @ 1000 / 124 (18) @ 2000 / 165 (24) @ 4000 Hot
Type oil intake (floating, stationary)	Stationary
Oil filter system (full flow, part, other)	Full Flow
Capacity of c/case, less filter-refill-L (qt.)	3.8 (4.0)

Engine - Diesel Information

(NOT APPLICABLE)

Diesel engine manufacturer		
Glow plug, current drain at 0°F.		
Injector nozzle	Type	
	Opening pressure kPa (psi)	
Pre-chamber design		
Fuel injection pump	Manufacturer	
	Type	
Fuel injection pump drive (belt, chain, gear)		
Supplementary vacuum source (type)		
Fuel heater (yes/no)		
Water separator, description (std., opt.)		
Turbo manufacturer		
Oil cooler-type (oil to engine coolant, oil to ambient air)		
Oil filter		

Engine - Intake System

(NOT APPLICABLE)

Turbo charger - manufacturer	
Super charger - manufacturer	
Intercooler	

* Finished State

MVMA Specifications

Vehicle Line IMPALA SS SEDAN
 Model Year 1996 Issued _____ Revised (#) _____

METRIC (U.S. Customary)

Engine Description
 Engine Code

5.7 LITER V8 (350 CID)
 SEQUENTIAL FUEL INJECTION RPO LT1

Engine - Cooling System

Coolant recovery system (std., opt., n.a.)	Pressurized Coolant System	
Coolant fill location (rad., bottle)	Bottle, Coolant Recovery	
Radiator cap relief valve pressure kPa (psi)	Reservoir Cap; 103.4 (15.0)	
Circulation thermostat	Type (choke, bypass)	Choke, Suction Side
	Starts to open at °C (°F)	82 (180)
Water pump	Type (centrifugal, other)	Centrifugal
	GMP 1000 pump rpm	14
	Number of pumps	1
	Drive (V-belt, other)	Serpentine Belt
	Bearing type	Sealed Double Row Ball
	Impeller material	Steel
	Housing material	Cast Aluminum
By-pass recirculation type (inter., ext.)	Internal	
Cooling System capacity	With heater - L (qt.)	Not Applicable
	With air conditioner - L (qt.)	14.3 (15.1)
	Opt. equipment specify - L (qt.)	15.9 (16.8), Heavy Duty Cooling
Water jackets full length of cyl. (yes, no)	Yes	
Water all around cylinder (yes, no)	Yes	
Water jackets open at head face (yes, no)	Yes	
Radiator core	Std., A/C, HD	Standard
	Type (cross-flow, etc.)	Cross Flow
	Construction (fin & tube mechanical, braze, etc.)	Fin & Tube, Solder
	Material, mass kg (wgt., lbs.)	Aluminum, Hi-Efficiency
	Width	762 mm (30.0 in.)
	Height	438 mm (17.2 in.)
	Thickness	34 mm (1.3 in.)
Fins per inch	3.0	
Radiator end tank material	Nylon	
Fan	Std., elec., opt.	Standard, Electric
	Number of blades & type (flex, solid, material)	5 Blade, Polypropylene
	Number & location (front, rear of radiator)	2 Fans, Rearward of Radiator
	Diameter & projected width	360 mm (14.2 in.)
	Ratio (fan to crankshaft rev.)	Heavy Duty Clutch/Fan & 240 W. Electric
	Fan cutout type	ECM Control
	Drive type (direct, remote)	Electric Motor
	RPM at idle (elec.)	Pri. (150 W) 1900-2000 RPM; Sec. (100 W) 1800-1900 RPM; HD 150 W / 240 W
	Motor rating (wattage/elec.)	Pri. (150 W/12V) Right Side; Sec. (100 W/12V) Left Side; HD 150 W / 240 W
	Motor switch (type & location/elec.)	Relay
	Switch point (temp./pressure/elec.)	Both Fans Electric on W/250 PSIG & Above on AC
Fan shroud (material)	Polypropylene	

MVMA Specifications

Vehicle Line IMPALA SS SEDAN
 Model Year 1996 Issued _____ Revised (*) _____

METRIC (U.S. Customary)

Engine Description
 Engine Code

5.7 LITER V8 (350 CID)
 SEQUENTIAL FUEL INJECTION RPO LT1

Engine - Fuel System (See supplemental page for details of Fuel Injection, Supercharger, Turbocharger, etc. if used.)

Induction type: carburetor, fuel injection system, etc.		Sequential Port Fuel Injection
Manufacturer		AC Rochester Products
Carburetor no. of barrels		None
Idle A/F mix.		Preset - No Adjustment
Fuel injection	Point of injection (no.)	Fuel Injectors at Inlet Ports
	Constant, pulse, flow	Pulse
	Control (electronic, mech.)	Electronic - On Board Computer
	System pressure kPa (psi)	300 (43.5)
Idle speed-rpm (spec. neutral or drive and propane if used)	Manual	Not Applicable
	Automatic	PCM Controlled
Intake manifold heat control (exhaust or water thermostatic or fixed)		None
Air cleaner type		Replaceable Paper Element
Fuel filter (type/location)		409 Stainless Steel 12 / Attach to Frame, Right Side
Fuel pump	Type (elec. or mech.)	Electric
	Location (eng., tank)	Fuel Tank
	Pressure range kPa (psi)	Normal 83.0 (12.0), Shut Off 135 (19.6)
	Flow rate at regulated pressure L (gal)/hr @ kPa (psi)	23-30 gr/sec @ 83 (12.0)

Fuel Tank

Capacity refill L (gallons)		87 (23)
Location (describe)		Below Rear Compartment Pan
Attachment		Straps
Material & Mass kg. (weight lbs.)		HDPE Mass - w/o Sender 11.1 kg.; w/Sender 12.7 kg.
Filter pipe	Location & material	Rear 1008 - 1010 Steel; Coating Lead/Tin
	Connection to tank	Clamped w/Hose Coupler
Fuel line (material)		Nylon Tubing 12
Fuel hose (material)		Rubber
Return line (material)		Nylon Tubing 12
Vapor line (material)		Nylon Tubing 12
Extended range tank	Opt., n.s.	Not Applicable
	Capacity L (gallons)	-
	Location & material	-
	Attachment	-
Auxiliary tank	Opt., n.s.	Not Applicable
	Capacity L (gallons)	-
	Location & material	-
	Attachment	-
	Selector switch or valve	-
Separate fill		-

MVMA Specifications

Vehicle Line IMPALA SS SEDAN
 Model Year 1996 Issued _____ Revised (*) _____

METRIC (U.S. Customary)

Engine Description
 Engine Code

5.7 LITER V8 (350 CID)
 SEQUENTIAL FUEL INJECTION RPO LT1

Vehicle Emission Control

Type (air injection, engine modifications, other)		Air Injection w/Computer Command Control		
Exhaust Emission Control	Air injection	Pump or pulse	Vane	
		Driven by	Electric	
		Air distribution (head, manifold, etc.)	Exhaust Manifold	
		Point of entry	Exhaust Manifold	
	Exhaust Gas Recirculation	Type (controlled flow, open orifice, other)	Controlled Flow	
		Exhaust source		
		Point of exhaust injection (spacer, carburetor, manifold, other)	Manifold	
	Catalytic Converter	Type	3 Way	
		Number of	2	
		Location(s)	LH - Close Coupled; RH - Underbody	
Volume L (in ³)		1.54 (94.1), Each		
Substrate type		Monolith		
Noble metal type		Platinum (Pt), Rhodium (Rh)		
Crankcase Emission Control	Type (ventilates to atmosphere, induction system, other)	Induction System		
	Energy source (manifold vacuum, carburetor, other)	Manifold Vacuum		
	Discharges to (intake manifold, other)	Intake Plenum		
	Air inlet (breather cap, other)	Air Cleaner		
Evaporative Emission Control	Vapor vented to (crankcase, canister, other)	Fuel Tank	Canister	
		Carburetor	-	
	Vapor storage provision	Canister		
Electronic system	Closed loop (yes/no)	Yes		
	Open loop (yes/no)	No		

Engine - Exhaust System

Type (single, single with cross-over, dual, other)	Dual	
Muffler no. & type (reverse flow, straight thru, separate resonator), Muffler volume (liters), Material & Mass kg. (weight lbs.)	2. Reverse Flow	
Resonator no., type, & volume (liters)	2. Straight	
Exhaust pipe	Branch o.d., wall thickness	50.08 mm (1.97 in.)
	Main o.d., wall thickness	57.15 mm (2.25 in.), 1.8 mm (.070 in.) Min.
	Material & Mass kg. (weight lbs.)	Stainless Steel, 3.4 (7.5)
Intermediate pipe	o.d. & wall thickness	63.5 mm (2.5 in.); 1.40 mm (.055 in.) Min.
	Material & Mass kg. (weight lbs.)	Stainless Steel, 10.645 kg. (23.46 in.)
Tail pipe	o.d. & wall thickness	63.5 mm (2.5 in.); 1.73 mm (.068 in.), Min.
	Material & Mass kg. (weight lbs.)	Stainless Steel, 6.415 (14.1)

MVMA Specifications

Vehicle Line IMPALA SS SEDAN
 Model Year 1996 Issued _____ Revised (*) _____

METRIC (U.S. Customary)

Engine Description
 Engine Code

5.7 LITER V8 (350 CID)
 SEQUENTIAL FUEL INJECTION RPO LT1

Transmissions/Transaxle (Std., Opt., N.A.)

Manual 4-speed (manufacturer/country)	Not Available
Manual 5-speed (manufacturer/country)	"
Manual 6-speed (manufacturer/country)	"
Automatic (manufacturer/country)	"
Automatic overdrive (manufacturer/country)	Hydra-Matic, U.S.A. (M30)

Manual Transmission/Transaxle (NOT APPLICABLE)

Number of forward speeds		
Gear ratios	1st	
	2nd	
	3rd	
	4th	
	5th	
	6th	
	Reverse	
Synchronous meshing (specify gears)		
Shift lever location		
Trans. case material & mass kg. (lbs.)*		
Lubricant	Capacity L (pt.)	
	Type recommended	

Cluth (Manual Transmission) (NOT APPLICABLE)

Clutch manufacturer		
Clutch type (dry, wet; single, multiple disc)		
Linkage (hydraulic, cable, rod, lever, other)		
Max. pedal effort (nom. spring load) N (lbs.)	Depressed	
	Released	
Axial (spring, power/percent, nominal)		
Type pressure plate springs		
Total spring load (nominal) N (lbs.)		
Clutch facing	Facing mfg. & material coding	
	Facing material & construction	
	Rivets per facing	
	Outside x inside dia. (nominal)	
	Total eff. area cm ² (in. ²)	
	Thickness (pressure plate side/fly wheel side)	
	Rivet depth (pressure plate side/fly wheel side)	
Engagement cushion method		
Release bearing type & method lub.		
Torsional damping method, springs, hysteresis		

* Includes shift linkage, lubricant, and clutch housing. If other specify.

MVMA Specifications

Vehicle Line IMPALA SS SEDAN
 Model Year 1996 Issued _____ Revised (*) _____

METRIC (U.S. Customary)

Engine Description	5.7 LITER V8 (350 CID)
Engine Code	SEQUENTIAL FUEL INJECTION RPO LT1

Automatic Transmission/Transaxle

Trade Name		GM Powertrain 4L60E
Type and special features (describe)		Electronic, 4-Speed Automatic, Overdrive 4th Gear Lock Up Torque Converter Clutch
Shift mechanics		
Gear selector	Location (column, floor, other)	Column
	Ltr./No. designation (e.g. PRND21)	P-R-N-(D)-D-2-1
	Shift interlock (yes, no, describe)	Yes
Gear ratios	1st	3.059
	2nd	1.625
	3rd	1.000
	4th	0.696
	5th	-
	6th	-
	Reverse	2.294
	Final drive ratio	3.08
Max. upshift vehicle speed - drive range km/h (mph)		1 - 2 = 72 (45) 2 - 3 = 132 (82)
Max. upshift engine speed RPM		5150 RPM
Max. lockdown speed - drive range km/h (mph)		3 - 2 = 116 (72) 2 - 1 = 56 (35)
Min. overdrive speed km/h (mph)		47 (29)
Torque converter	Type	3 Element with Converter Clutch
	Torus design	Full
	Number of elements	3
	Max. ratio at stall	1.91
	Type of cooling (air, liquid)	Liquid
	Nominal diameter	298 mm
Capacity factor "K"		100
Pump type		Vane
Lubricant	Capacity refill L (pt.)	4.8 (10)
	Type recommended	Dexron III
Oil cooler (std., opt., N.A., internal, external, air, liquid)		External, Liquid
Transmission mass kg (lbs.) & case material**		83 (184) Wet, Aluminum

All Wheel / 4 Wheel Drive

(NOT APPLICABLE)

Description & type (part-time, full-time, 2/4 shift while moving, mechanical, elect., chain/gear, etc.)		
Transfer case	Manufacturer and model	
	Type and location	
Low-range gear ratio		
System disconnect (describe)		
Center differential	Type (bevel, planetary, w or w/o viscous bias, torsen, etc.)	
	Torque split (% front/rear)	

* Input speed + $\sqrt{\text{torque}}$

** Dry weight including torque converter. If other, specify.

MVMA Specifications

Vehicle Line IMPALA SS SEDAN
 Model Year 1996 Issued _____ Revised (#) _____

METRIC (U.S. Customary)

Engine Description
 Engine Code

5.7 LITER V8 (350 CID)
 SEQUENTIAL FUEL INJECTION RPO LT1

Axle Ratio and Tooth Combinations (See 'Power Teams' for axle ratio usage)

Axle ratio (or overall top gear ratio)		3.08
Ring gear o.d.		8.60
No. of teeth	Pinion	13
	Ring gear	40

Rear Axle Unit

Description		Semi-Floating Axle, Overhung Hypoid Drive Pinion and Ring Gear
Limited slip differential (type)		Cone Clutch (Limited Slip Required)
Drive pinion	Type	Hypoid Gear
	Offset	44.0 (1.75)
No. of differential pinions		2
Pinion / differential	Adjustment (shim, etc.)	Shim
	Bearing adjustment	Collapsible Sleeve
Driving wheel bearing (type)		Direct on Single Row Cylindrical
Lubricant	Capacity L (pt.)	2.0 (4.2)
	Type recommended	GL-5 Gear Lubricant

Propeller Shaft - Rear Wheel Drive

Manufacturer Type (straight tube, tube-in-tube, internal-external damper, etc.)		Straight Tube	
Outer diam. x length* x wall thickness	Manual 4-speed transmission	Not Applicable	
	Manual 5-speed transmission	"	
	Manual 6-speed transmission	"	
	Overdrive	"	
	Automatic transmission	76.2 x 1384 x 2.11 mm (3.00 x 54.49 x .083 in.) LT1 & 4L60E & 8.6" Axle	
Intermediate bearing	Type (plain, anti-friction)	None	
	Lubrication (fitting, prepack)	None	
Slip yoke	Type	Splined	
	Number of teeth	27	
	Spline o.d.	29.858 (1.175)	
Universal joints	Make and mfg. no.	Front	American Axle, S-44
		Rear	American Axle, S-44
	Number used	2	
	Type (ball and trunnion, cross)	Cross	
	Rear attach (u-bolt, clamp, etc.)	Strap & Bolt	
	Bearing	Type (plain, anti-friction)	Anti-Friction
Lubrication (fitting, prepack)		Pre-Packed	
Drive taken through (torque tube, arms or springs)		Control Arm	
Torque taken through (torque tube, arms or springs)		Control Arm	

* Centerline to centerline of universal joints, or to centerline of rear attachment.

MVMA Specifications

Vehicle Line IMPALA SS SEDAN
 Model Year 1996 Issued _____ Revised (●) _____

METRIC (U.S. Customary)

Model Code/Description And/Or
 Engine Code/Description

5.7 LITER V8 (350 CID)
 SEQUENTIAL FUEL INJECTION RPO LT1

Suspension - General Including Electronic Controls

Car leveling	Standard/optional/not available	Not Applicable	
	Manual/automatic control	"	
	Type (air/hydraulic)	"	
	Primary/assist spring	"	
	Rear only/4 wheel leveling	"	
	Single/dual rate spring	"	
	Single/dual ride heights	"	
Shock absorber damping controls	Standard/option/not available	Not Applicable	
	Manual/automatic control	"	
	Number of damping rates	"	
	Type of actuation (manual/electric motor/air, etc.)	"	
	Sensors	Lateral acceleration	"
		Deceleration	"
		Acceleration	"
Road surface		"	
Shock absorber (front & rear)	Type	Mono Tube High Pressure Gas Charged / FE4	
	Make	DeCarbone	
	Piston diameter	46 mm (1.64 in.)	
	Rod diameter	11.5 mm (.46 in.)	

Suspension - Front

Type and description		SLA
Travel	Full jounce (define load condition)	90 mm (3.4 in.) @ Design (3-Passenger)
	Full rebound	108 mm (4.3 in.) @ Design (3-Passenger)
Spring	Type (coil, leaf, other & material)	Coil (Steel/Warm Set, Painted)
	Insulators (type & material)	Front Upper (Natural Rubber)
	Size (Leaf: length & width; Coil: design height & i.d.; Bar: length & diameter)	Checking Height 296.8 mm (11.7 in.) Coil: I.D. 102.9 mm (4.05 in.)
	Spring rate N/mm (lb./in.)	FE4 Sedan 77 (440)
	Rate at wheel N/mm (lb./in.)	FE4 Sedan 39 (223)
Stabilizer	Type (link, linkless, frameless)	Link
	Material & O.D. bar/tube, wall thickness	Solid Steel, 30.0 mm (1.18 in.)

Suspension - Rear

Type and description		4-Link, Solid Axle
Travel	Full jounce (define load condition)	110 mm (4.3 in.) @ Design (3-Passenger)
	Full rebound	129 mm (5.1 in.) @ Design (3-Passenger)
Spring	Type (coil, leaf, other & material)	Coil (Steel, Warm Set, Paint)
	Size (Leaf: length & width; Coil: design height & i.d.; Bar: length & diameter)	Checking Height 296.8 mm (11.7 in.) Coil: I.D. 102.9 mm (4.05 in.)
	Spring rate N/mm (lb./in.)	FE4 Sedan 27 (154)
	Rate at wheel N/mm (lb./in.)	FE4 Sedan 26.6 (152)
	Insulators (type & material)	Upper (Butyl)
	If leaf	No. of leaves
Shackle (comp. or tens.)		"
Stabilizer	Type (link, linkless, frameless)	FE4, Link
	Material & O.D. bar/tube, wall thickness	26.0 mm (1.02 in.) FE4
Track bar (type)		Not Applicable

MVMA Specifications

Vehicle Line IMPALA SS SEDAN
 Model Year 1996 Issued _____ Revised (*) _____

METRIC (U.S. Customary)

Model Code/Description And/Or
 Engine Code/Description

ALL

Brakes - Service

Description		Single Caliper Disc Front & Rear			
Manufacturer and brake type (std., opt., n.a.)	Front (disc or drum)	Delco Chassis Division, Standard Disc			
	Rear (disc or drum)	Delco Chassis Division, Standard Disc			
Valving type (proportion, delay, metering, other)		Combination, Metering and Proportioning			
Power brake (std., opt., n.a.)		Standard			
Booster type (remote, integral, vac., hyd., etc.)		Vacuum			
Vacuum	Source (inline, pump, etc.)	Engine Manifold			
	Reservoir (volume in. ³)	Not Applicable			
	Pump-type (elec., gear or belt driven)	"			
Traction assist	Operational speed range	"			
	Type (engine or brake intervention)	"			
Antilock device	Front/rear (std., opt., n.a.)	Standard			
	Manufacturer	Robert Bosch Corporation			
	Type (electronic, mech.)	Electronic			
	Number sensors or circuits	3			
	Number antilock hydraulic circuits	3			
	Integral or add-on system	Add-On			
	Yaw control (yes, no)	Yes			
Hyd. power source (elec., vac., mtr., pwr., strp.)	Electrical				
Effective area cm ² (in. ²)*		740 (114.7)			
Gross Lining area cm ² (in. ²)** (F/R)		270.2 (41.9) / 521.5 (80.8)			
Swept area cm ² (in. ²)*** (F/R)		1563.3 (242.3) / 883.9 (137.0)			
Rotor (Front)	Outer working diameter	305 mm (12 in.)			
	Inner working diameter	208 mm (8.19 in.)			
	Thickness	25.4 mm (1 in.)			
	Material & type (vented/solid)	Cast Iron Vented			
Rotor (Rear)	Outer working diameter	295 mm (11.6 in.)			
	Inner working diameter	208 mm (8.0 in.)			
	Thickness	20.32 mm (0.8 in.)			
	Material & type (vented/solid)	Cast Iron Vented			
Wheel cylinder bore		25.4 mm (1.0 in.)			
Master cylinder	Bore/stroke	F/R	28.6 mm Bore / 37.06 mm Stroke (Worst Case)		
Pedal arc ratio		3.5:1			
Line press. at 445 N (100 lb.) pedal load [kPa (psi)]		8614 kPa (1250 psi)			
Lining clearance		F/R	0 mm (0 in.) / .75 mm (.030 in.)		
Brake lining	Front wheel	Bonded or riveted (rivets/seg.)		Riveted (8)	
		Rivet Size		Head: 9.1mm (.359 in.) / Shank: 5.3 mm (.21 in.)	
		Manufacturer		Delco Chassis Division	
		Lining code ****			
		Material		Bendix 7822 D	
		****	Primary or out-board	65.11 cu. cm (3.97 cu. in.)	
		****	Secondary or in-board	77.0 cu. cm (4.70 cu. in.)	
	Shoe thickness (no lining)		3.2 mm (.125 in.) Outboard/5.1 mm (.200 in.) Inboard		
	Rear wheel	Bonded or riveted (rvts/seg.)		Riveted	
		Manufacturer		Delco Chassis Division	
		Lining code ****			
		Material		DM 4035/4050, Police	
		****	Primary or out-board	77.08 cu. cm (4.80 cu. in.)	
****		Secondary or in-board	114.47 cu. cm (7.11 cu. in.)		
Shoe thickness (no lining)		1.80-2.16 mm (.071-.085 in.)			

* Excludes rivet holes, grooves, chamfers, etc.

** Includes rivet holes, grooves, chamfers, etc.

*** Total swept area for four brakes. (Drum brake: Widest lining contact width for each brake x its contact circumference.) (Disc brake: Square of Outer Working Dia. minus Square of inner Working Dia. multiplied by Pi/2 for each brake.)

**** Size for drum brakes includes length x width x thickness. *****Manufacturer I.D., catalog for formulation designation and coefficient of friction classification.

MVMA Specifications

Vehicle Line IMPALA SS SEDAN
 Model Year 1996 Issued _____ Revised (#) _____

METRIC (U.S. Customary)

Model Code/Description And/Or
 Engine Code/Description

ALL

Tires And Wheels (Standard)

Tires	Size (service description)		P255/50 ZR17
	Type (bias, radial, steel, nylon, etc.)		Radial
	Inflation pressure (cold) for recommended max. vehicle load	Front kPa (psi)	207 (30)
		Rear kPa (psi)	207 (30)
	Rev./mile at 70 km/h (45 mph)		477 km (768 mph)
Wheels	Type & material		Cast Aluminum
	Rim (size & flange type)		17 x 8 1/2 'J'
	Wheel offset		6.0 mm
	Attachment	Type (bolt or stud & nut)	Stud & Nut
		Circle diameter	5"
Number & size		5 x 12 mm	
Spare	Tire and wheel		P215/75 R15 with 15 x 7 Steel Wheel
	Storage position & location (describe)		Rearward in Trunk - Under Shelf Panel

Tires And Wheels (Optional)

(NOT APPLICABLE)

Tire size (service description)	
Type (bias, radial, steel, nylon, etc.)	
Wheel (type & material)	
Rim (size, flange type and offset)	
Tire size (service description)	
Type (bias, radial, steel, nylon, etc.)	
Wheel (type & material)	
Rim (size, flange type and offset)	
Tire size (service description)	
Type (bias, radial, steel, nylon, etc.)	
Wheel (type & material)	
Rim (size, flange type and offset)	
Tire size (service description)	
Type (bias, radial, steel, nylon, etc.)	
Wheel (type & material)	
Rim (size, flange type and offset)	
Spare tire and wheel size	
(if configuration is different than road tire or wheel, describe optional spare tire and/or wheel location & storage position)	

Brakes - Parking

Type of control	Pedal	
Location of control	Dash Panel	
Operates on	Cable	
If separate from service brakes	Type (internal or external)	Internal
	Drum diameter	279 mm (11.0 in.)
	Lining size (length x width x thickness)	Primary 77.08 cu. cm Secondary 114.47 cu. cm.

MVMA Specifications

Vehicle Line IMPALA SS
 Model Year 1996 Issued _____ Revised (®) _____

METRIC (U.S. Customary)

Model Code/Description And/Or
 Engine Code/Description

SEDAN

Steering

Manual (std., opt., n.s.)		Not Applicable				
Power (std., opt., n.s.)		Standard				
Speed-sensitive (std., opt., n.s.)		Not Applicable				
4-wheel steering (std., opt., n.s.)		Not Applicable				
Adjustable steering wheel/column (tilt, telescope, other)	Type	Tilt				
	Manufacturer	Saginaw Division				
	(std., opt., n.s.)	Standard				
Wheel diameter** (W9) SAE J1100	Manual	Not Applicable				
	Power	387 mm O.D.				
Turning diameter m (ft.)	Outside front	Wall to wall (l. & r.)	LT (44' - 10") RT (45' - 8")			
		Curb to curb (l. & r.)	LT (43' - 11") RT (43' - 7")			
	Inside rear	Wall to wall (l. & r.)	LT (26' - 3") RT (26' - 11")			
		Curb to curb (l. & r.)	LT (26' - 4") RT (27' - 1")			
Scrub Radius*		Not Available				
Manual	Gear	Type	Not Applicable			
		Manufacturer	-			
		Ratios	<table border="1"> <tr> <td>Gear</td> <td>-</td> </tr> <tr> <td>Overall</td> <td>-</td> </tr> </table>	Gear	-	Overall
	Gear	-				
Overall	-					
No. wheel turns (stop to stop)		-				
Power	Type (coaxial, elec. hyd., etc.)		Hydraulic			
	Manufacturer		Saginaw Division			
	Gear	Type	Integral			
		Ratios	<table border="1"> <tr> <td>Gear</td> <td>12.7:1</td> </tr> <tr> <td>Overall</td> <td>15.3</td> </tr> </table>	Gear	12.7:1	Overall
	Gear	12.7:1				
Overall	15.3					
Pump (drive)		Belt				
No. wheel turns (stop to stop)		3.06				
Linkage	Type		Parallelogram w/Lube Fittings			
	Location (front or rear of wheels, other)		Front			
	Tie rods (one or two)		See Linkage			
Steering axis	Inclination at camber (deg.)		0 ± .8			
	Bearings (type)	Upper	Not Applicable			
		Lower	-			
Thrust		-				
Steering spindle/knuckle & joint type		Tapered Stud				

* The horizontal distance in the front elevation between wheel centerline and kingpin (ball joint) axis at ground.

** See Page 23.

MVMA Specifications

Vehicle Line IMPALA SS SEDAN
 Model Year 1996 Issued Revised (●)

METRIC (U.S. Customary)

Model Code/Description And/Or
 Engine Code/Description

ALL

Wheel Alignment

Front wheel at curb mass (wt.)	Service checking	Caster (deg.)	3.5 (±) 1.0
		Camber (deg.)	0.0 (±) 0.8
		Toe-in outside track mm (in.)	0.16 (±) 0.20
	Service reset*	Caster (deg.)	2.8 (±) 3.5
		Camber (deg.)	0.8 (±) 0.8
		Toe-in mm (in.)	0.16 (±) 0.16
	Periodic M.V. inspection	Caster (deg.)	2.8 (±) 1.0
		Camber (deg.)	0.0 (±) 0.8
		Toe-in mm (in.)	0.16 (±) 0.20
Rear wheel at curb mass (wt.)	Service checking	Camber (deg.)	Not Applicable
		Toe-in outside track mm (in.)	"
	Service reset*	Camber (deg.)	"
		Toe-in mm (in.)	"
	Periodic M.V. insp.	Camber (deg.)	"
		Toe-in mm (in.)	"

* Indicates pre-set, adjustable, trend set or other.

Electrical - Instruments and Equipment

Speedometer	Type (analog, digital, std., opt.)	Digital Standard	
	Trip odometer (std., opt., n.a.)	Standard	
Head-up display	Standard, optional, not available		Not Applicable
	Type	Secondary, opto-electronic	"
	Speedometer	Digital	"
	Status/warning indicators	Turn signals, high beam, low fuel, check gauges	"
	Brightness control	Day / night mode, adjustable	"
EGR maintenance indicator		None	
Charge indicator	Type	Gage	
	Warning device (light, audible)	Light	
Temperature indicator	Type	Gage	
	Warning device (light, audible)	Light	
Oil pressure indicator	Type	Telltale	
	Warning device (light, audible)	Light	
Fuel indicator	Type	Gage	
	Warning device (light, audible)	N.A.	
Windshield wiper	Type (standard)	Delay	
	Type (optional)	None	
	Blade length	22 in.	
	Swept area cm ² (in. ²)	7655.8 (1186.9)	
Windshield washer	Type (standard)	Centrifugal Pump - Demand Wash	
	Type (optional)	Not Applicable	
	Fluid level indicator (light, audible)	Light	
Rear window wiper, wiper/washer (std., opt., n.a.)		Not Applicable	
Horn	Type	Delco	
	Number used	2	
Other		Low Coolant Indicator, Telltale-Light Low Oil Level Indicator, Telltale-Light Change Oil Monitor, Telltale Airbag - Telltale-Light	

MVMA Specifications

Vehicle Line IMPALA SS SEDAN
 Model Year 1996 Issued _____ Revised (*) _____

METRIC (U.S. Customary)

Engine Code/Description

5.7 LITER V8 (350 CID)
 SEQUENTIAL FUEL INJECTION RPO LT1

Electrical - Supply System

Battery	Manufacturer	Delco Remy
	Model, std., (opt.)	Standard
	Voltage	12 V
	Amps at 0° F. cold crank	525
	Minutes-reserve capacity	90 Min. Reserve
	Amps/hrs. -20 hr. rate	54 Amps/hrs.
	Location	Engine Compartment, Right Front
Alternator	Manufacturer	Delco Remy
	Rating (idle/max. rpm)	36/100 (1600/6500 Generator RPM)
	Ratio (alt. crank/rev.)	3.0
	Output at idle (rpm, park)	36 Amps
	Optional (type & rating)	-
Regulator	Type	Temperature Compensated Per Curve "C" - 6507

Electrical - Starting System

Motor	Manufacturer	Nippon Denso
	Current drain @ 0 °C (°F)	350 Amps
	Power rating kw (hp)	1.6 (2.1)
Motor drive	Engagement type	Positive Shift Solenoid
	Pinion engages from (front, rear)	Rear

Electrical - Ignition System

Type	Electronic (std., opt., n.s.)	-	
	Other (specify)	Opti-Spark Ignition System	
Coil	Manufacturer	Delco Remy	
	Model		
	Current	Engine stopped - A	-
		Engine idling - A	-
Spark plug	Manufacturer	AC Rochester	
	Model	R45LTSP	
	Thread (mm)	M14 x 1.25	
	Tightening torque N-m (lb. ft.)	24-30 (18-22)	
	Gap	1.27 (0.050 in.)	
	Number per cylinder	1	
Distributor	Manufacturer	Delco Remy	
	Model	1103878	

Electrical - Suppression

Locations & type	Internal Generator Capacitor, Non-Metallic High-Tension Cables, Resistor Spark Plugs, Ignition Coil By-Pass Capacitor, Internal AC Blower Motor By-Pass Capacitor & A/C Compression Diode, with Radio Provisions; Fuse Block Capacitor and On "Heater Only" Blower Motors and Coax Capacitor.
------------------	---

MVMA Specifications

Vehicle Line IMPALA SS
 Model Year 1996 Issued _____ Revised (#) _____

METRIC (U.S. Customary)

Model Code/Description

SEDAN

Body

Structure	All Welded Heavy-Gage Steel Body. Full Perimeter Frame
Bumper system front - rear	Frame Mounted Steel Beam on Delco Energy Absorbers Covered with Urethane Fascia. Performance 5 mph.
Anti-corrosion treatment	2-Sided Galvanized A - METAL REQUIREMENTS 1. Quarter 2. Door Inner & Outer 3. Fender Inner & Outer 4. Hood Inner & Outer 5. Decklid Inner & Outer B - SUBSEQUENT COATINGS 1. Phosphate 2. Cathodic Elpo 3. Augmented Waxes

Body - Miscellaneous Information

Type of finish (lacquer, enamel, other)	Base-Coat/Clear-Coat	
Hood	Material & mass	Steel, Hood Assembly with Grille, Brakes, Insulator (26.5)
	Hinge location (front, rear)	Rear
	Type (counterbalance, prop)	Gas Spring
	Release control (internal, external)	Internal
Trunk lid	Material & mass	Steel, (19.6)
	Type (counterbalance, other)	Torque Rod
	Internal release control (elec., mech., n.a.)	Electric
Hatchback lid	Material & mass	Not Applicable
	Type (counterbalance, other)	"
	Internal release control (elec., mech., n.a.)	"
Tailgate	Material & mass	"
	Type (drop, lift, door)	"
	Internal release control (elec., mech., n.a.)	"
Vent window control (crank, friction, pivot, power)	Front	Not Applicable
	Rear	"
Window regulator type (cable, tape, flex drive, etc.)	Front	Cross-Arm Regulator
	Rear	Cross-Arm Regulator
Seat cushion type (e.g., 60/40 bucket, bench, wire, foam, etc.)	Front	Wire Susp.; 45 Driver, 45 Pass.
	Rear	Bench Std., Wire/Foam Suspension
	3rd seat	Not Applicable
Seat back type (e.g., 60/40 bucket, bench, wire, foam, etc.)	Front	Wire Susp.; 45 Driver, 45 Pass., Wire Susp.
	Rear	Wire/Foam Susp.
	3rd seat	Not Applicable

Frame

Type and description (separate frame, unitized frame, partially-unitized frame)	Separate Frame. Sedan: 2 Crossmembers
---	---------------------------------------

MVMA Specifications

Vehicle Line IMPALA SS SEDAN
 Model Year 1996 Issued _____ Revised (#) _____

METRIC (U.S. Customary)

Model Code/Description

SEDAN

Restraint System

Seating Position			Left	Center	Right
Active	Type & description (lap & shoulder belt, lap belt, etc.) Standard / Optional	First seat	Lap and Shoulder Belt		Lap and Shoulder Belt
		Second seat	Lap and Shoulder Belt	Lap Belt	Lap and Shoulder Belt
		Third seat	Not Applicable	Not Applicable	Not Applicable
Passive	Type & description (air bag, motorized-2-point belt, fixed belt, knee bolster, manual-lap belt) Standard / Optional	First seat	Supplemental Inflatable Restraint	Not Applicable	Supplemental Inflatable Restraint
		Second seat	Not Applicable	Not Applicable	Not Applicable
		Third seat	Not Applicable	Not Applicable	Not Applicable
Glass		SAE Ref.No.			
Windshield glass exposed surface area cm ² (in. ²)		S1	7276.8 (1127.9)		
Side glass exposed surface area cm ² (in. ²) - total 2 sides		S2	18124.5 (2809.3)		
Rearlight glass exposed surface area cm ² (in. ²)		S3	5919.4 (917.5)		
Total glass exposed surface area cm ² (in. ²)		S4	31320.7 (4854.7)		
Windshield glass (type/thickness)			Curved - Laminated Plate, 5.5 mm		
Side glass (type/thickness)			Curved - Tempered Plate, 4.0 mm		
Rearlight glass (type/thickness)			Curved - Tempered Plate, 5.5 mm		
Tinted (yes/no, location)		A	Yes, Windshield		
Solar control (yes/no, coated/batched, location)			No		

Headlamps

Description (sealed beam, halogen, replaceable bulb, etc.)	Replacement Bulb
Shape	Contoured
Lo-beam type (2A1, 2B1, 2C1, etc.)	9004 Bulb
Quantity	2 Per Vehicle
Hi-beam type (1A1, 2A1, 1C1, 2C1, etc.)	Included in Lo-Beam Bulb 9004
Quantity	2 Per Vehicle

MVMA Specifications

Vehicle Line IMPALA SS SEDAN
 Model Year 1996 Issued Revised (●)

METRIC (U.S. Customary)

Engine Code/Description

ALL

Climate Control System

Air conditioning (std., opt., man., auto.)		Standard: Electronic Climate Control
Condenser	Type	Tube & Fin
	Eff. face area (sq. mm.)	308,250
	Fins per inch	13
Evaporator	Type	
	Eff. face area (sq. mm.)	75,600
	Fins per inch	
Heater core	Material	Aluminum
	Eff. face area (sq. mm.)	33,600
	Fins per inch	13
Compressor	Type	Axial (6) Cylinder
	Displacement (cc.)	110
	Manufacturer	Harrison Division, G.M.
	A/C pulley ratio	1.43
Accumulator	Type	
	Height (mm.)	205
	Diameter (mm.)	88
Receiver	Type	
	Height (mm.)	
	Diameter (mm.)	
Refrigerant control (CCOT, TVS, etc.)		CCOT
Heater water valve (yes / no)		No
Refrigerant (R - 12, R - 134a, etc.)		R134A
Charge level (lbs. - oz.)		1.75 lbs.
Cold engine lockout switch (yes / no)		No
Wide open throttle cutout switch (yes / no)		No

MVMA Specifications

Vehicle Line IMPALA SS SEDAN
 Model Year 1996 Issued _____ Revised (#) _____

METRIC (U.S. Customary)

Model Code/Description

SEDAN

Convenience Equipment (standard, optional, n.a.)

	Clock (digital, analog)	Digital - In Radio
	Compass / thermometer	Not Applicable
	Console (floor, overhead)	Floor
	Defroster, electric windshield	None
	Defroster, electric backlight	Optional
Electronic	Diagnostic monitor (integrated, individual)	Low Oil Level Indicator, Washer, Coolant, Fuel, Oil Level Indicators, Change Oil Monitor
	Instrument cluster (list instruments)	Speedo Fuel Temp
	Keyless entry	Standard
	Trip/reminder (avg. spd., fuel)	Not Applicable
	Voice alert (list items)	Not Applicable
	Other	
	Fuel door lock (remote, key, electric)	Not Applicable
Integrated Child Seating	Std./opt. & location in vehicle	Not Applicable
	Number of occupants	Not Applicable
	Occupant weight/height (min. & max.)	Not Applicable
	Restraint system description (3 or 5-point belts/booster seat capability)	Not Applicable
Lamps	Auto head on/off delay, dimming	Standard
	Cornering	Standard
	Courtesy (map, reading)	Courtesy (Door) - Standard Reading Lamps - Standard
	Door lock, ignition	None
	Engine compartment	Standard, RH Side
	Fog	None
	Glove compartment	Standard
	Trunk	Standard
	Illuminated entry system (list lamps, activation)	Standard (Interior Lights)
	Other	Center High-Mounted Stop Lamp Standard
Mirrors	Day / night (auto., man.)	Manual
	L.H. (remote, power, heated)	Power - Standard, Power Heated - Optional
	R.H. (convex, remote, power, heated)	Power - Standard, Power Heated - Optional (Convex Mirror)
	Visor vanity (RH / LH, illuminated)	Non-illuminated - LH & RH, Standard / Optional RH - Illuminated
	Navigation system (describe)	Not Applicable
	Parting brake-auto release (warning light)	Base Light

MVMA Specifications

Vehicle Line IMPALA SS SEDAN
 Model Year 1996 Issued _____ Revised (#) _____

METRIC (U.S. Customary)

Model Code/Description

SEDAN

Convenience Equipment (standard, optional, n.a.)

Power equipment	Deck lid (release, pull down)		Release - Standard
	Door locks (manual, automatic, describe system)		Power - Standard
	Seats	2 - 4 - 6 way, etc.	6-Way LH Standard; 6-Way RH Optional
		Reclining (R.H., L.H.)	Manual RH & LH on all Split Seats
		Memory (R.H., L.H., preset recline)	None
		Support (lumbar, hip, thigh, etc.)	None
		Heated (R.H., L.H., other)	None
	Side windows		Power - Standard
	Vent windows		None
	Rear windows		Not Applicable
Radio systems	Antenna (location, whip, w/shield, power)		Whip RH Front Fender; Power - Optional
	Standard	AM, FM, stereo, tape, compact disc, graphic equalizer, theft deterrent, radio prep package, headphone jacks, etc.	UM6 - AM/FM Stereo Seek, Scan, Auto Reverse, Cass., Clock - ETR
	Optional		UL0 - AM/FM Stereo Seek, Scan, Auto Reverse, Cassette, Clock, ATC. - ETR UN0 - AM/FM Stereo Seek, Scan, CD, Clock ETR, ATC, w/Delco Lock II (Anti-Theft)
	Speaker (number, location)		4 Speakers - 1 Each Front Door, 2 Rear Shelf
Roof: open air or fixed (flip-up, sliding, "T")			Not Applicable
Speed control device			Cruise Control - Stepper Motor
Speed warning device (light, buzzer, etc.)			Not Applicable
Tachometer (rpm)			*
Telephone system (describe)			*
Theft deterrent system			Pass Key II

Trailer Towing

Towing capable	Yes / No	Class I (Base)
Engine / transmission / axle	Std. / Opt.	LT1; M30 4L60E (Standard) 3.08
Tow class (I, II, III)*	Std. / Opt.	
Max. gross trailer wgt. (lbs.)	Std / Opt.	2000 (Maximum)
Max. trailer tongue load (lbs.)	Std. / Opt.	240 w/Weight Distr. Hitch
Towing package available	Yes / No	

* Class I - 2,000 lbs. Class II - 3,500 lbs. Class III - 5,000 lbs.

MV Specifications

Vehicle Line IMPALA SS SEDAN
 Model Year 1996 Issued _____ Revised (●) _____

METRIC (U.S. Customary)

Vehicle Dimensions See Key Sheets for definitions

All dimensions to ground are for comparative purposes only. Dimensions are to be shown for all base body models of each vehicle line. SAE Ref. No. refers to the definition published in SAE Recommended Practice J1100 "Motor Vehicle Dimensions," unless otherwise specified.

Model/Description	SAE Ref. No.	SEDAN
Width		
Tread (front)	W101	1582 (62.3)
Tread (rear)	W102	1593 (62.7)
Vehicle width	W103	1968 (77.5)
Body width SgRP (front)	W117	1953 (76.9)
Vehicle width (front doors open)	W120	3589 (141.3)
Vehicle width (rear doors open)	W121	3468 (136.6)
Turn angle (degrees)	W122	27.5
Outside mirror width	W410	2114 (83.2)

Length

Wheelbase	L101	2945 (115.9)
Vehicle length	L103	5439 (214.1)
Overhang (front)	L104	1059 (41.7)
Overhang (rear)	L105	1435 (56.5)
Upper structure length	L123	3143 (123.7)
Rear wheel C/L "X" coordinate	L127	4475 (176.3)

Height **

Passenger distribution (front/rear)	PD1, 2,3	Not Available	**
Truck load			**
Vehicle height	H101	1389 (54.7)	
Cowl point to ground	H114	970 (38.2)	
Deck point to ground	H138	1063 (41.9)	
Rocker panel-front to ground	H112	256 (10.1)	
Rocker panel-rear to ground	H111	270 (10.6)	
Windshield slope angle (degrees)	H122	60.5	
Backlight slope angle (degrees)	H121	65.5	

Ground Clearance **

Front bumper to ground	H102	256 (10.1), EPA
Rear bumper to ground	H104	320 (12.6), EPA
Buttress ground front at curb (wt.)	H103	283 (11.1), Curb
Buttress ground rear at curb (wt.)	H105	360 (14.2), Curb
Angle of approach (degrees)	H106	16 EPA
Angle of departure (degrees)	H107	9.4 EPA
Rear wheel over angle (degrees)	H147	14.1 EPA, 9.9 GVM
Axle differential to ground (front/rear)	H153	193 (7.6)
Min. running ground clearance	H156	178.7 (7.0), Curb 157.0 (6.2), EPA
Location of min. running ground clear.		Rear Lower Trailing Arm Bracket

** All Height And Ground Clearance Are Made Using EPA Loaded Vehicle Weight, Loading Conditions.

EPA vehicle weight is the base vehicle weight plus all coolant and fluids necessary for operation plus 100% of the fuel capacity, plus the weight of all options and accessories which weigh three pounds or more and which are sold on at least 33% of the car line, plus two occupants.

All dimensions are in millimeters (inches).

MVMA Specifications

Vehicle Line IMPALA SS SEDAN
 Model Year 1996 Issued _____ Revised (#) _____

METRIC (U.S. Customary)

Vehicle Dimensions

See Key **_____** for definitions

Model Code/Description	SAE Ref. No.	SEDAN
------------------------	--------------	--------------

Front Compartment

SgRP front, "X" coordinate	L31	3078 (121.2)
Effective head room	H61	986 (39.2)
Max. effective leg room (accelerator)	L34	1072.0 (42.2)
SgRP to heel point	H30	320.0 (8.7)
SgRP to heel point	L53	976.0 (34.5)
Back angle (degrees)	L40	36.5
Hip angle (degrees)	L42	97
Knee angle (degrees)	L44	127
Foot angle (degrees)	L46	67
Design H-point front travel	L17	163.0 (6.4)
Normal driving & riding seat track trvl.	L23	143.0 (5.6)
Shoulder room	W3	1610.0 (63.4)
Hip room	W5	1448.0 (57.0)
Upper body opening to ground	H50	1347 (53.0)
Steering wheel maximum diameter*	W9	367.0 (15.2)
Steering wheel angle (degrees)	H18	19
Accel. heel pt. to steer. whl. cntr.	L11	555 (21.9)
Accel. heel pt. to steer. whl. cntr.	H17	629.0 (24.8)
Undepressed floor covering thickness	H67	9.0 (0.35)

Front Compartment Interior Dimensions are Measured with the Seating Reference Point (SgRP) 20 mm forward and _____ mm Upward of Rearmost Position.

Rear Compartment

SgRP point coupe distance	L50	882.0 (34.7)
Effective head room	H63	963 (37.9)
Min. effective leg room	L51	1002 (39.5)
SgRP (second to heel)	H31	292.0 (11.5)
Knee clearance	L48	64 (2.5)
Shoulder room	W4	1610.0 (63.4)
Hip room	W6	1445.0 (56.9)
Upper body opening to ground	H51	1362 (53.6)
Back angle (degrees)	L41	25
Hip angle (degrees)	L43	93
Knee angle (degrees)	L45	110
Foot angle (degrees)	L47	127.5
Depressed floor covering thickness	H73	18

Luggage Compartment

Usable luggage capacity L (cu. ft.)	V1	577.4 (20.4)
Liftover height	H195	785.5 (30.9)

Interior Volumes (EPA Classification)

Vehicle class	Large
Interior volume index including trunk/cargo (cu. ft.)**	134.6 = Pass. Area 114.2 (Frt. 60.2 + Rr. 54.0) + Trunk Area 20.4
Trunk/cargo index (cu. ft.)	20.4

* See page 14.

** See definition page 33.

All linear dimensions are in millimeters (inches) unless otherwise noted.

*** EPA Loaded Vehicle Weight, Loading Conditions

MVMA Specifications

Vehicle Line IMPALA SS SEDAN
 Model Year 1996 Issued _____ Revised (●) _____

METRIC (U.S. Customary)

Vehicle Dimensions See Key Sheets for definitions

Model Code/Description	SAE Ref. No.	SEDAN
------------------------	--------------	-------

Station Wagon/MPV* -Third Seat

(NOT APPLICABLE)

Seat facing direction	SD1	
SgRP couple distance	L85	
Shoulder room	W85	
Hip room	W86	
Effective leg room	L86	
Effective head room	H86	
SgRP to heel point	H87	
Knee clearance	L87	
Back angle (degrees)	L88	
Hip angle (degrees)	L89	
Knee angle (degrees)	L90	
Foot angle (degrees)	L91	

Station Wagon/MPV* - Cargo Space

(NOT APPLICABLE)

Cargo length (open front)	L200	
Cargo length (open second)	L201	
Cargo length (closed front)	L202	
Cargo length (closed second)	L203	
Cargo length at belt (front)	L204	
Cargo length at belt (second)	L205	
Cargo width (wheelhouse)	W201	
Rear opening width at floor	W203	
Opening width at belt	W204	
Min. rear opening width above belt	W205	
Cargo height	H201	
Rear opening height	H202	
Tailgate to ground height	H250	
Front seat back to load floor height	H197	
Cargo volume index m ³ (ft. ³)	V2	
Hidden cargo volume index m ³ (ft. ³)	V4	
Cargo volume index-rear of 2-seat	V10	
Cargo volume index**	V6	
Cargo width at floor**	W500	
Maximum cargo height*	H505	

Hatchback - Cargo Space

(NOT APPLICABLE)

Cargo length at front seatback height	L208	
Cargo length at floor (front)	L209	
Cargo length at second seatback height	L210	
Cargo length at floor (second)	L211	
Front seatback to load floor height	H197	
Second seatback to load floor height	H198	
Cargo volume index m ³ (ft. ³)	V3	
Hidden cargo volume index m ³ (ft. ³)	V4	
Cargo volume index - rear of 2-seat	V11	

All linear dimensions are in millimeters (inches) unless otherwise noted.

* MPV - Multipurpose Vehicle

** EPA Loaded Vehicle Weight, Loading Conditions

MVMA Specifications

Vehicle Line IMPALA SS SEDAN
 Model Year 1996 issued Revised (●)

METRIC (U.S. Customary)

Model Code/
Description

SEDAN

Vehicle Fiducial Marks

Fiducial Mark Number*	Define Coordinate Location	
Front	X - Fiducial mark to vertical zero grid line - front measured horizontally, from the zero grid line to the front fiducial mark located on top of the front seat adjuster mounting bolt. Y - Fiducial mark to centerline of car - front, width measurement made from centerline car to fiducial mark located on top of the front seat adjuster mounting bolt. Z - Fiducial mark to horizontal zero grid line - front, measured vertically from zero grid line to front fiducial mark located on top of the front seat adjuster mounting bolt.	
Rear	X - Fiducial mark to vertical zero grid line - rear, measured horizontally from the zero grid line to rear fiducial mark located on the rail (compartment pan - longitudinal.) Y - Fiducial mark to centerline of car - rear, width measurement made from centerline of car to fiducial mark located on the rail (compartment pan - longitudinal.) Z - Fiducial mark to horizontal zero grid line - rear, measured vertically from the zero grid line to rear fiducial mark located on the rail (compartment pan - longitudinal.)	
NOTE: Provide 3 of 4 Fiducial Mark Locations		
Front	W21**	564 (22.2)
	L54**	2754 (108.4)
	H81**	509 (20.0)
	*** H161**	348 (13.7), Curb
	*** H163**	392 (15.4)
Rear	W22**	254 (10.0)
	L55**	5533 (217.8)
	H82**	586 (23.1)
	*** H162**	446 (17.6)
	*** H164**	359 (14.1)

* Reference - SAE Recommended Practice, J182a, Motor Vehicle Fiducial Marks.

** Reference - SAE Recommended Practice J1100 - Motor Vehicle Dimensions.

*** EPA Loaded Vehicle Weight, Loading Conditions

All linear dimensions are in millimeters (inches) unless otherwise noted.

MVMA Specifications
METRIC (U.S. Customary)

Vehicle Line IMPALA SS SEDAN
 Model Year 1996 Issued _____ Revised (*) _____

		Optional Equipment Differential Mass (weight)*			
Code	Equipment	MASS, kg. (lb.)			Remarks Restrictions, Requirements
		Front	Rear	Total	
AG2	Seat Adjuster - 6-Way Power Passenger	3.2 (7.0)	1.0 (2.2)	4.2 (9.2)	
AN4	Child Restraint Provisions	0 (0)	.4 (.9)	.4 (.9)	1BL19
AP9	Convenience Net	0 (0)	.2 (.4)	.2 (.4)	
AU0	Lock Control - Remote Entry	.6 (1.3)	.4 (.9)	1.0 (2.2)	1BL19
AU3	Lock - Side Door, Electric	.6 (1.3)	.6 (1.3)	1.2 (2.6)	
A90	Lock - Rear Compartment Lid, Remote Control Electric	-2 (-.4)	.8 (1.7)	.6 (1.3)	
BC5	Interior Ornamentation Load Comp	-2 (-.4)	.8 (1.7)	.6 (1.3)	
B18	Ornamentation - Interior, Deluxe	.2 (.4)	0 (0)	.2 (.4)	1BL19
B45	Trim Equipment Delete Fleet	0 (0)	-2.0 (-4.4)	-2.0 (-4.4)	
B48	Trim - Luggage Compartment	0 (0)	3.2 (7.0)	3.2 (7.0)	
B81	Exterior Ornamentation - Body Side Delete	-6 (-1.3)	-1.0 (-2.2)	-1.6 (-3.5)	1BL19
C49	Defogger - Rear Window, Electric	.2 (.4)	.2 (.4)	.4 (.8)	
C71	Lamp - Interior Front Door	.2 (.4)	0 (0)	.2 (.4)	
C96	Lamps	.2 (.4)	0 (0)	.2 (.4)	
DC4	Mirror - I/S, R/V Tilt R/Lamp	.2 (.4)	0 (0)	.2 (.4)	
DD2	Mirror - I/S, Sunshade, Covered	.2 (.4)	0 (0)	.2 (.4)	

* Also see Engine - General Section for dressed engine mass (weight.)

MVMA Specifications
METRIC (U.S. Customary)

Vehicle Line IMPALA SS SEDAN
 Model Year 1996 Issued _____ Revised (●) _____

Code	Equipment	Optional Equipment Differential Mass (weight)*			Remarks Restrictions, Requirements
		MASS, kg. (lb.)			
		Front	Rear	Total	
DL8	Mirror - Outside Rear	.6 (1.3)	0 (0)	.6 (1.3)	
D64	Mirror - Visor (Illuminated)	.2 (.4)	0 (0)	.2 (.4)	
FE2	Suspension System - Ride, Handling	3.0 (6.6)	8.0 (17.6)	11.0 (24.2)	
FE3	Suspension System - Sport	3.8 (8.4)	9.2 (20.3)	13.0 (28.7)	
F41	Suspension System - Front/Rear, Firm Ride, Handling	3.0 (6.6)	8.0 (17.6)	11.0 (24.2)	
GU4	Axle - Rear (3.08 Ratio)	0 (0)	12.0 (26.5)	12.0 (26.5)	
G80	Axle - Rear (Limited Slip)	0 (0)	3.6 (7.9)	3.6 (7.9)	1BA00
IHD	Trim - Interior Design	.2 (.4)	.2 (.4)	.4 (.9)	
IHN	Trim - Interior Design	1.8 (4.0)	1.8 (4.0)	3.6 (7.9)	
IQD	Trim - Interior Design	.8 (1.8)	.8 (1.8)	1.6 (3.5)	
1QN	Trim - Interior Design	1.8 (4.0)	1.8 (4.0)	3.6 (7.9)	
1Q2	Trim - Interior Design	1.6 (3.5)	1.6 (3.5)	3.2 (7.0)	
1RD	Trim - Interior Design A52	.2 (.4)	.2 (.4)	.4 (.9)	
IRN	Trim - Interior Design A52	1.8 (4.0)	1.8 (4.0)	3.6 (7.9)	
JA2	Brake - System Heavy Duty	0 (0)	13.0 (28.7)	13.0 (28.7)	1BL19 & GU5
JA2	Brake - System Heavy Duty	0 (0)	14.0 (30.9)	14.0 (30.9)	1BL19 & GU2
JA9	Brake Heavy Weight, Disc/Disc	0 (0)	10.8 (23.8)	10.8 (23.8)	1BL19 & GU5
KC4	Cooling System - Engine Oil	1.4 (3.1)	0 (0)	1.4 (3.1)	

* Also see Engine - General Section for dressed engine mass (weight.)

MVMA Specifications
METRIC (U.S. Customary)

Vehicle Line IMPALA SS SEDAN
 Model Year 1996 Issued _____ Revised (®) _____

		Optional Equipment Differential Mass (weight)*			
Code	Equipment	MASS, kg. (lb.)			Remarks Restrictions, Requirements
		Front	Rear	Total	
UQ5	Speaker System - 4 Dual	.2 (.4)	.8 (1.8)	1.0 (2.2)	
U1C	Radio - AM/FM Stereo Seek & Scan	.8 (1.8)	.2 (.4)	1.0 (2.2)	
U75	Antenna - Power, Radio	1.0 (2.2)	0 (0)	1.0 (2.2)	
VK3	License Plate Rear Mounted Pkg. - Exp.	.4 (.9)	0 (0)	.4 (.9)	
V03	Cooling System - Extra Capacity	1.0 (2.2)	-.2 (-.4)	.8 (1.8)	
1T1	Hose - Radiator & Heater (Sp.) Sil. Rub	.4 (.9)	0 (0)	.4 (.9)	
122	Anti-Corrosion Hot Melt	1.0 (2.2)	1.0 (2.2)	2.0 (4.4)	
142	Trim Comb - Leather, Light Gray	.4 (.9)	.4 (.9)	.8 (1.8)	
6A3	Mat. - H/D Front & Rear	2.4 (5.3)	2.4 (5.3)	4.8 (10.6)	
6F8	Tray - Ash Side Front Doors	.2 (.4)	0 (0)	.2 (.4)	
6G2	Reinforced - Roof Panel	1.6 (3.5)	1.6 (3.5)	3.2 (7.0)	
6J1	Wiring - Ignition & Main Power	.8 (1.8)	.4 (.8)	1.2 (2.6)	
6J2	Wiring - Headlight, Flash, Grille Light	.2 (.4)	0 (0)	.2 (.4)	
6J3	Wiring - Headlight, Flash, Grille Left Speaker	.6 (1.3)	.4 (.9)	1.0 (2.2)	
6J6	Lamp Package - Rear Panel Lights	0 (0)	1.6 (3.5)	1.6 (3.5)	1BL19
7B3	Suspension - Special Handling	3.8 (8.4)	9.2 (20.3)	13.0 (28.7)	
7L9	Cooler - Hydraulic Steering Oil	.4 (.9)	0 (0)	.4 (.9)	
7P8	Cooler - Engine Oil	4.2 (9.3)	0 (0)	4.2 (9.3)	

* Also see Engine - General Section for dressed engine mass (weight.)

MVMA Specifications
METRIC (U.S. Customary)

Vehicle Line IMPALA SS SEDAN
 Model Year 1996 Issued _____ Revised (e) _____

		Optional Equipment Differential Mass (weight)*			
Code	Equipment	MASS, kg. (lb.)			Remarks Restrictions, Requirements
		Front	Rear	Total	
U75	Antenna - Power, Radio	1.0 (2.2)	0 (0)	1.0 (2.2)	
VK3	License Plate Rear Mounted Pkg. - Exp.	.4 (.9)	0 (0)	.4 (.9)	
V03	Cooling System - Extra Capacity	1.0 (2.2)	-2 (-.4)	.8 (1.8)	
V08	Radiator - Heavy Duty (Req. W/V92)	3.0 (6.6)	0 (0)	3.0 (6.6)	
1T1	Hose - Radiator & Heater (Sp.) Sil. Rub	.4 (.9)	0 (0)	.4 (.9)	
1Z2	Anti-Corrosion Hot Melt	1.0 (2.2)	1.0 (2.2)	2.0 (4.4)	
142	Trim Comb - Leather, Light Gray	.4 (.9)	.4 (.9)	.8 (1.8)	
5AN	Tire - P225/70HR 15	4.0 (8.8)	4.0 (8.8)	8.0 (17.6)	1BL19
5AQ	Tire - P225/70HR 15	4.0 (8.8)	4.0 (8.8)	8.0 (17.6)	1BL19 & R4Z
5AQ	Tire - P225/70HR 15	1.4 (3.1)	1.4 (3.1)	2.8 (6.2)	1BL19 & R4Y
6A3	Mat - H/D Front & Rear	2.4 (5.3)	2.4 (5.3)	4.8 (10.6)	
6F8	Tray - Ash Side Front Doors	.2 (.4)	0 (0)	.2 (.4)	
6G2	Reinforced - Roof Panel	1.6 (3.5)	1.6 (3.5)	3.2 (7.0)	
6J1	Wiring - Ignition & Main Power	.8 (1.8)	.4 (.8)	1.2 (2.6)	
6J2	Wiring - Headlight, Flash, Grille Light	.2 (.4)	0 (0)	.2 (.4)	
6J3	Wiring - Headlight, Flash, Grille Left Speaker	.6 (1.3)	.4 (.9)	1.0 (2.2)	
6J6	Lamp Package - Rear Panel Lights	0 (0)	1.6 (3.5)	1.6 (3.5)	1BL19

* Also see Engine - General Section for dressed engine mass (weight.)

AAMA Specifications
METRIC (U.S. Customary)

- Exterior Vehicle And Body Dimensions - Key Sheet

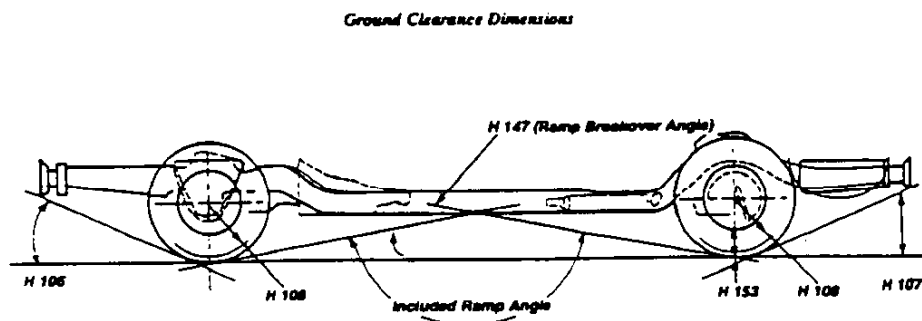
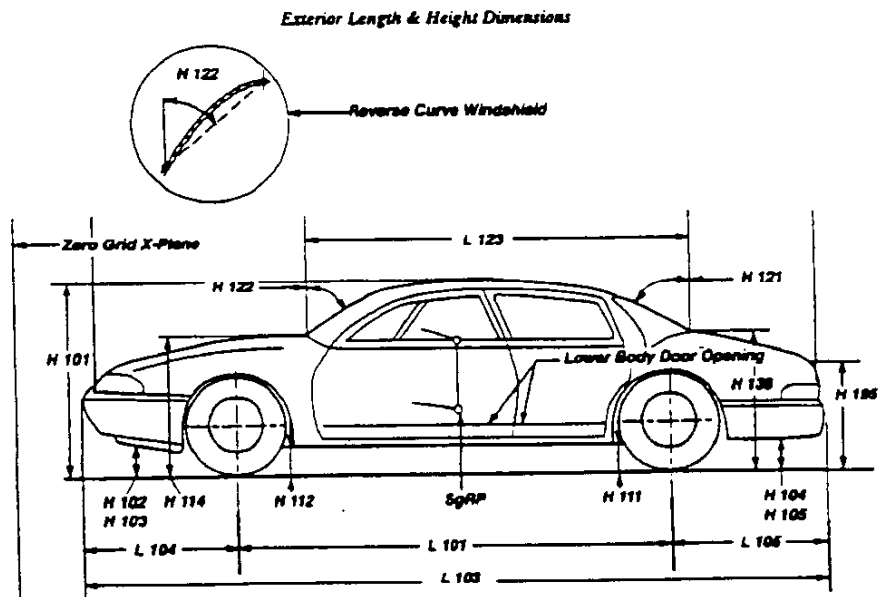
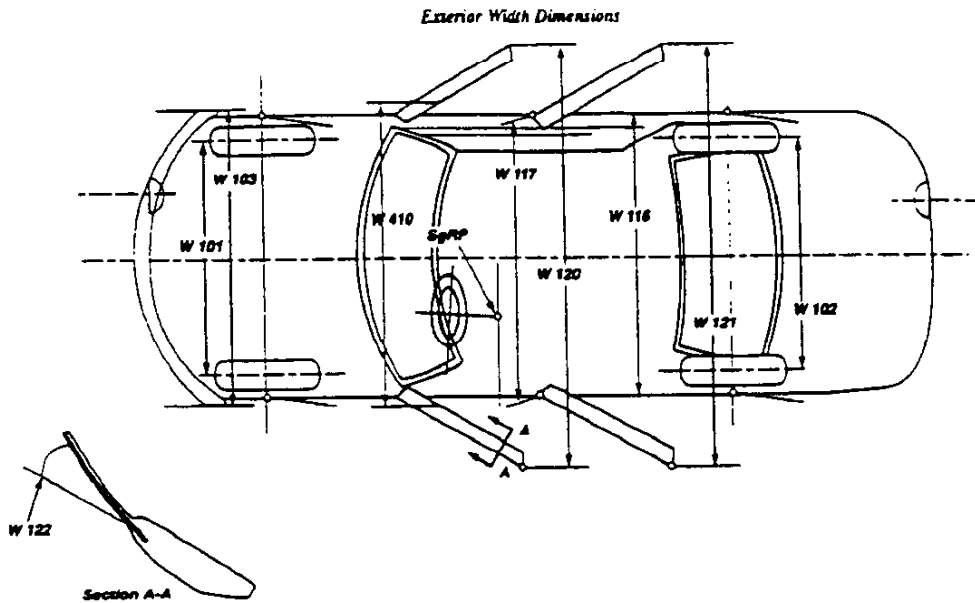

**AAMA Specifications
METRIC (U.S. Customary)**

Interior Vehicle And Body Dimensions - Key Sheet

Interior Length Dimensions

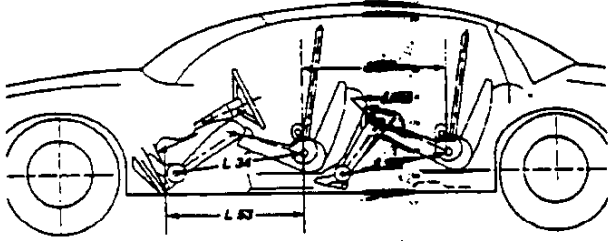

Interior Height Dimensions

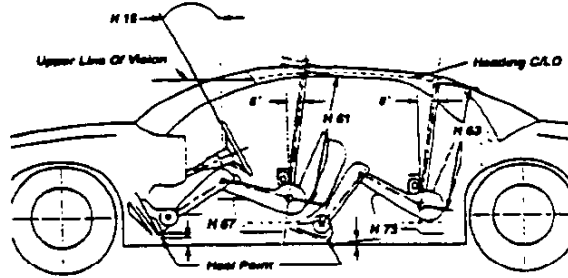

Interior Height Dimensions

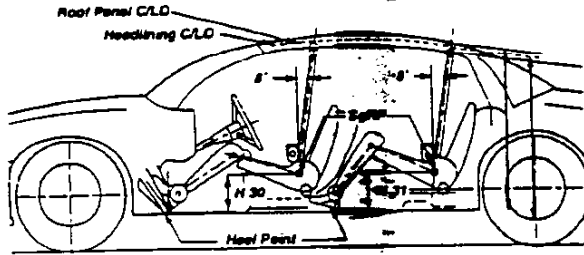

Interior Length Dimensions

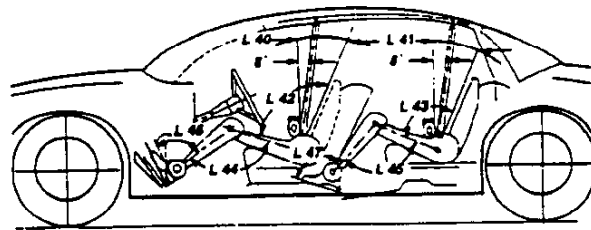

Interior Width Dimensions

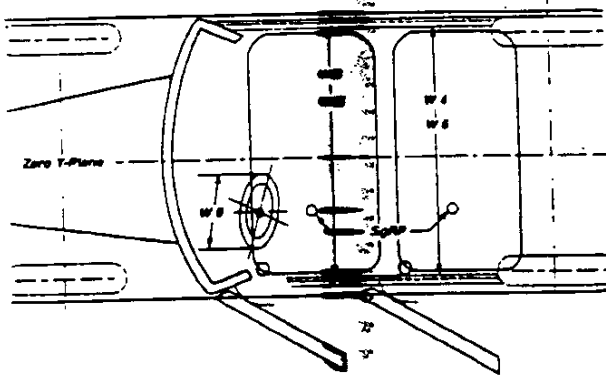

Interior Height Dimensions

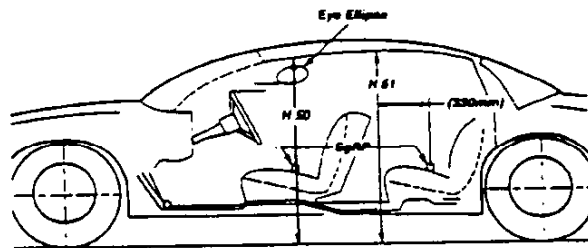

**AAMA Specifications
METRIC (U.S. Customary)**

Interior Vehicle And Body Dimensions - Key Sheet

Interior Dimensions, Seated, Meets Third Seat

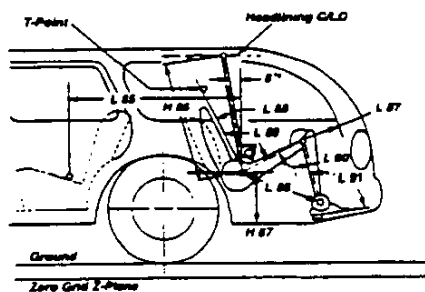

Interior Dimensions

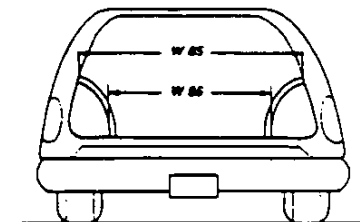

Cargo Space Dimensions

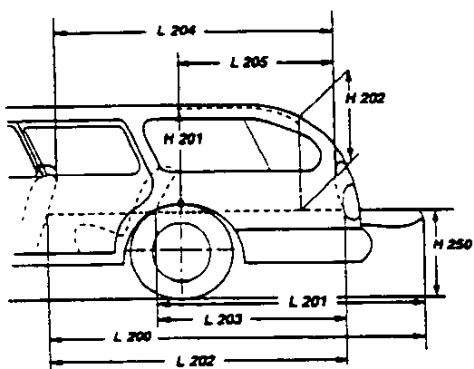

Cargo Space Dimensions

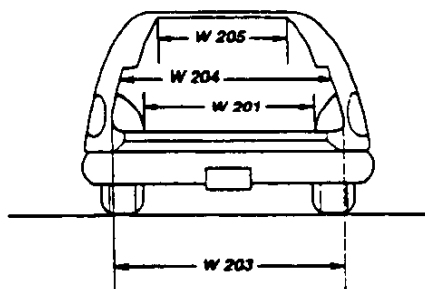

Cargo Space Dimensions

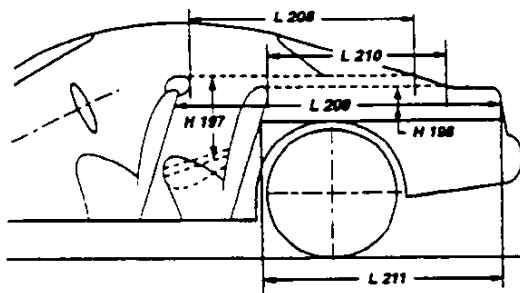

Multipurpose Vehicle Cargo Space

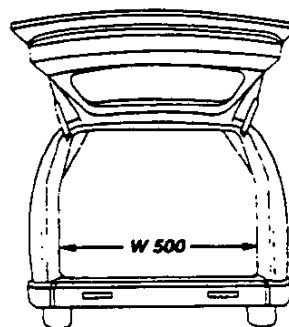
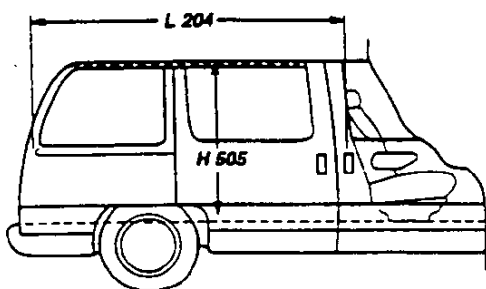

AAMA Specifications

METRIC (U. S. Customary)

Exterior Vehicle And Body Dimensions - Key Sheet

Dimensions Definitions

Seating Reference Point

SEATING REFERENCE POINT means the manufacturer's design reference point which -

- (a) Establishes the rearmost normal design driving or riding position of each designated seating position in a vehicle;
- (b) Has coordinates established relative to the design vehicle structure;
- (c) Simulates the position of the pivot center of the human torso and thigh; and
- (d) is the reference point employed to position the two dimensional templates described in SAE Recommended Practice J826, "Devices for Use in Defining and Measuring Vehicle Seating Accommodations."

Width Dimensions

- W101 TREAD-FRONT.** The dimension measured between the tire centerlines at the ground.
- W102 TREAD-REAR.** The dimension measured between the tire centerlines at the ground. In case of dual wheels, the dimension will be measured to the centerline of tire and wheel assemblies.
- W103 VEHICLE WIDTH.** The maximum dimension measured between the widest point on the vehicle, excluding exterior mirrors, flexible mud flaps, marker lamps, but including bumpers, moldings, sheet metal protrusions or dual wheels, if standard equipment.
- W117 BODY WIDTH AT SgRP-FRONT.** The dimension measured laterally between the widest points on the body at the SGRP-front, excluding door handles, applied moldings, or appliques.
- W120 VEHICLE WIDTH-FRONT DOORS OPEN.** The dimension measured between the widest point on the rear doors in maximum hold-open position.
- W121 VEHICLE WIDTH-REAR DOORS OPEN.** The dimension measured between the widest point on the rear doors in maximum hold-open position. For vehicles with a rear door on only one side, this dimension is to the zero "Y" plane.
- W122 TUMBLE-HOME. STRAIGHT SIDE GLASS.** The angle measured from a vertical to the outside surface of the front door glass at the SgRP "X" plane.
CURVED SIDE GLASS. The angle measured from a vertical to a chord extending from the upper DLO to the lower DLO at the outside surface of the front door glass at the front SgRP "X" plane.
- W410 OUTSIDE MIRROR WIDTH:** The dimension between the widest point on the outside mirrors. The standard right and left mirror adjusted for normal driving will be shown unless otherwise noted. When only one outside mirror is standard, the dimension will be to the zero "Y" plane.

Length Dimensions

- L101 WHEELBASE (WB).** The dimension measured longitudinally between front and rear wheel centerline. In case of dual rear axles, the dimension shall be to the midpoint of the centerlines of the rear wheels.
- L103 VEHICLE LENGTH.** The maximum dimension measured longitudinally between the foremost point and the rearmost point on the vehicle, including bumper, bumper guards, tow hooks and/or rub strips, if standard equipment.
- L104 OVERHANG-FRONT.** The dimension measured longitudinally from the centerline of the front wheels to the foremost point on the vehicle including bumper, bumper guards, tow hook and/or rub strips, if standard equipment.
- L105 OVERHANG-REAR.** The dimension measured longitudinally from the centerline of the rear wheels; or in the case of dual rear axles, the dimension shall be the midpoint of the centerlines of the rear wheels, to the rearmost point on the vehicle including rear bumpers, bumper guards, tow hooks and rub strips, if standard equipment.
- L123 UPPER STRUCTURE LENGTH.** The dimension measured longitudinally from the cowl point to the deck point.

- L127 REAR WHEEL CENTERLINE "x" COORDINATE** or in the case of dual rear axles, the coordinate shall be the midpoint of the distance between the rear axle centerlines.

Height Dimensions

- H101 VEHICLE HEIGHT.** The dimension measured vertically from the highest point on the vehicle body to ground.
- H111 ROCKER PANEL-REAR TO GROUND.** The dimension measured vertically from the bottom of the rocker or side quarter panel at the front of the rear wheel opening, excluding flanges, to ground.
- H112 ROCKER PANEL-FRONT TO GROUND.** The dimension measured vertically from the foremost point on the bottom of the rocker panels, excluding flanges, to ground.
- H114 COWL POINT TO GROUND.** Measured at zero "Y" plane.
- H121 BACKLIGHT SLOPE ANGLE.** The angle between the vertical reference line and the surface of backlight at vehicle zero "Y" plane. For curve backlight, the angle is to chord of backlight arc from lower DLO to upper DLO.
- H122 WINDSHIELD SLOPE ANGLE.** The angle between the vertical reference line and a chord of the windshield arc running from the lower DLO to the upper DLO at the vehicle zero "Y" plane. In the case of wrap over glass, the angle to be measured will be formed by a chord 457 mm (18.0 in.) long drawn from the lower DLO to the intersecting point on the windshield.
- H138 DECK POINT TO GROUND.** Measured at zero "Y" plane.
- H109 STATICLOAD-TIRE RADIUS-REAR.** Specified by the manufacturer in accordance with composite TIRE SECTION STANDARD.

Ground Clearance Dimensions

- H102 FRONT BUMPER TO GROUND.** The minimum dimension measured vertically from the lowest point on the front bumper to ground, including bumper guards, if standard equipment.
- H103 FRONT BUMPERTO GROUND-CURB MASS(WT.).** Measured in the same manner as H102.
- H104 REAR BUMPER TO GROUND.** The minimum dimension measured vertically from the lowest point on the rear bumper to ground, including bumper guards, if standard equipment.
- H105 REAR BUMPER TO GROUND-CURB MASS(WT.).** Measured in the same manner as H104.
- H106 ANGLE OF APPROACH.** The angle measured between a line tangent to the front tire static loaded radius arc and the initial point of structural interference forward of the front tire to ground. The limiting structural component shall be designated.
- H107 ANGLE OF DEPARTURE.** The angel measured between a line tangent to the rear tire static loaded radius arc and the initial point of structural interference rearward of the rear tire to ground. The limiting component shall be designated.
- H147 RAMP BREAKOVER ANGLE.** The angle measured between two lines tangent to the front and rear tire static loaded radius and intersecting at a point on the underside of the vehicle which defines the largest ramp over which the vehicle can roll.
- H153 REAR AXLE DIFFERENTIAL TO GROUND.** The minimum dimension measured from the rear axle differential to ground.
- H156 MINIMUM RUNNING GROUND CLEARANCE.** The minimum dimension measured from the sprung vehicle to ground. Specify location.

AAMA Specifications

METRIC (U. S. Customary)

Interior Vehicle And Body Dimensions - Key Sheet

Dimensions Definitions

Glass Areas

- S1 Windshield area.
 S2 Side windows area. Includes the front door, rear door, vents, and rear quarter windows on both sides of the vehicle.
 S3 Backlight areas.
 S4 Total area. Total of all areas (S1 + S2 + S3).

Fiducial Mark Dimensions

- Fiducial Mark - Number 1**
 L54 "X" coordinate.
 W21 "Y" coordinate.
 H81 "Z" coordinate.
 H161 Height "Z" coordinate to ground at curb weight.
 H163 Height "Z" coordinate to ground.
Fiducial Mark - Number 2
 L55 "X" coordinate.
 W22 "Y" coordinate.
 H82 "Z" coordinate.
 H162 Height "Z" coordinate to ground at curb weight.
 H164 Height "Z" coordinate to ground.

Front Compartment Dimensions

- L11 ACCELERATOR WHEEL POINT TO STEERING WHEEL CENTER. The dimension measured horizontally from the AHP to the intersection of the steering column centerline and a plane tangent to the upper surface of the steering wheel rim.
 L17 DESIGN-H-POINT-FRONT TRAVEL. The dimension measured horizontally between the design H-point-front in the foremost and rearmost seat track positions. (See SAE J1100)
 L23 NORMAL DRIVING AND RIDING SEAT TRACK TRAVEL. The dimension measured horizontally between a point on the design H-point travel line from the SgRP to the displaced point on the design H-point travel line with the seat moved to the foremost seat position, but not to include seat track travel used for purposes other than normal driving and riding positions. (See SAE J1100).
 L31 SgRP-Front. "X" Coordinated.
 L34 MAXIMUM EFFECTIVE LEG ROOM-ACCELERATOR. The dimension measured along a line from the ankle pivot center to the SgRP-front plus 254 mm (10.0 in.) measured with right foot on the underdepressed accelerator pedal. For vehicles with SgRP to heel (H30) greater than 18 in., the accelerator pedal may be depressed as specified by the manufacturer. If the accelerator is depressed, the manufacturer shall place foot flat on pedal and note the depression of the pedal.
 L40 BACK ANGLE-FRONT. The angle measured between a vertical line through the SgRP-front and the torso line. If the seatback is adjustable, use the normal driving and riding position specified by the manufacturer.
 L42 HIP ANGLE-FRONT. The angle measured between torso line and thigh centerline.
 L44 KNEE ANGLE-FRONT. The angle measured between thigh centerline and lower leg centerline measured on the right leg.
 L46 FOOT ANGLE-FRONT. The angle measured between the lower leg centerline and a line tangent to the ball and heel of the bare foot flesh line measured on the right leg. Ref SAE J826.
 L53 SgRP-FRONT TO HEEL. The dimension measured horizontally from the SgRP-front to the accelerator heel point.
 W3 SHOULDER ROOM-FRONT. The minimum dimension measured laterally between the trimmed surfaces on the "X" plane through the SgRP-front at height between the belt line and 254 mm (10.0 in.) above the SgRP-front, excluding the door assist strap and attaching parts.

- W5 HIP ROOM-FRONT. The minimum dimension measured laterally between the trimmed surfaces on the "X" plane through the SgRP-front within 25 mm (1.0 in.) below and 76 mm (3.0 in.) above the SgRP-front and 76 mm (3.0 in.) fore and aft of the SgRP-front.
 W9 STEERING WHEEL MAXIMUM OUTSIDE DIAMETER. Define if other than round.
 H7 ACCELERATOR HEEL POINT TO THE STEERING WHEEL CENTER. The dimension measured vertically from the AHP-front to the intersection of the steering column centerline to a plane tangent to the upper surface of the steering wheel rim.
 H18 STEERING WHEEL ANGLE. The angle measured from a vertical to the surface plane of the steering wheel.
 H30 SgRP-FRONT TO HEEL. The dimension measured vertically from the SgRP-front to the accelerator heel point.
 H50 UPPER BODY OPENING TO GROUND-FRONT. The dimension measured vertically from the trimmed body opening to the ground on the SgRP-front "X" plane.
 H61 EFFECTIVE HEAD ROOM-FRONT. The dimension measured along a line 8 deg. rear of vertical from the SgRP-front to the headlining plus 102 mm (4.0 in.).
 H67 FLOOR COVERING THICKNESS - UNDEPRESSED - FRONT. The dimension measured vertically from the surface of the undepressed floor covering to the underbody sheet metal at the accelerator heel point.

Rear Compartment Dimensions

- L41 BACK ANGLE-SECOND. The angle measured between a vertical line through the SgRP-second and the torso line.
 L43 HIP ANGLE-SECOND. The angle measured between torso line and thigh centerline.
 L45 KNEE ANGLE-SECOND. The angle measured between thigh centerline and lower leg centerline.
 L47 FOOT ANGLE-SECOND. The angle measured between the lower leg centerline and a line tangent to the ball and heel of the three-dimensional devices bare foot flesh line (Reference J826).
 L48 KNEE CLEARANCE-SECOND. The minimum dimension measured from the knee pivot center to the back of the front seatback minus 51 mm (2.0 in.).
 L50 SgRP COUPLE DISTANCE-SECOND. The dimension measured horizontally from the driver SgRP-front to the SgRP-second.
 L51 MINIMUM EFFECTIVE LEG ROOM-SECOND. The dimension measured along a line from the ankle pivot center to the SgRP-second plus 254 mm (10.0 in.).
 W4 SHOULDER ROOM-SECOND. The minimum dimension measured laterally between door or quarter trimmed surfaces on the "X" plane through the SgRP-second at height between 254-406 mm (10.0-16.0 in.) above the SgRP-second, excluding the door assist straps and attaching parts.
 W6 HIP ROOM-SECOND. Measured in the same manner as W5.
 H31 SgRP-SECOND TO HEEL. The dimension measured vertically from the SgRP-second to the two dimensional device heel point on the depressed floor covering.
 H51 UPPER BODY OPENING TO GROUND-SECOND. The dimension measured vertically from the trimmed body opening to the ground on the "X" plane 330 mm (13.0 in.) forward of the SgRP-second.
 H63 EFFECTIVE HEAD ROOM-SECOND. The dimension measured along a line 8 deg. rear of vertical from the SgRP to the headlining, plus 102 mm (4.0 in.).
 H73 FLOOR COVERING-DEPRESSED-SECOND. The dimension measured vertically from the heel point to the underbody sheet metal.

AAMA Specifications

METRIC (U. S. Customary)

Interior Vehicle And Body Dimensions - Key Sheet

Dimensions Definitions

Luggage Compartment Dimensions

V1 **USABLE LUGGAGE CAPACITY**-Total of volumes of individual pieces of standard luggage set plus H-boxes stowed in the luggage compartment in accordance with the procedure described in paragraph 8.2 of SAE-J1100a.

Interior Volumes (EPA Classification)

The Interior Index is listed for each body style except two seaters. The Interior Volume Index estimates the space in a car. It is based on four measurements - head room, shoulder room, hip room, and leg room - for the front and rear seats, plus trunk capacity.

The Trunk/Cargo Index is an estimate of the size of the trunk/cargo space. In station wagons and hatchbacks it is an estimate of the space behind the second seat.

Station Wagon/MPV - Third Seat Dimensions

L85 **SgRP COUPLE DISTANCE-THIRD**. The dimension measured horizontally from the SgRP-second to the SgRP-third.

L86 **EFFECTIVE LEG ROOM-THIRD**. The dimension measured along a line from the ankle pivot center to the SgRP-third plus 254 mm (10.0 in.).

L87 **KNEE CLEARANCE-THIRD**. The minimum dimension from the knee pivot center to the back of second seatback minus a constant of 51 mm (2.0in.). With rear-facing third seat, dimension is measured to closure.

L88 **BACK ANGLE-THIRD**. Measured in the same manner as L41.

L89 **HIP ANGLE-THIRD**. Measured in the same manner as L43.

L90 **KNEE ANGLE-THIRD**. Measured in the same manner as L45.

L91 **FOOT ANGLE-THIRD**. Measured in the same manner as L47.

W85 **SHOULDER ROOM-THIRD**. Measured in the same manner as W4.

W86 **HIP ROOM-THIRD**. Measured in the same manner as W5.

H86 **EFFECTIVE HEAD ROOM-THIRD**. The dimension, measured along a line 8 deg. from the SgRP-third to the headlining rear of vertical plus a constant of 102 mm (4.0 in.).

H87 **SgRP-THIRD TO HEEL POINT**

SD1 **SEAT FACING DIRECTION-THIRD**.

Station Wagon/MPV - Cargo Space Dimensions

L200 **CARGO LENGTH-OPEN-FRONT**. The minimum dimension measured longitudinally from the back of the front seatback at the height of the undepressed floor covering to the rearmost point on the undepressed floor covering on the open tailgate or cargo surface if the rear closure is a conventional door type tailgate at the zero "Y" plane.

L201 **CARGO LENGTH-OPEN-SECOND**. The dimension measured longitudinally from the back of the second seatback at the height of the undepressed floor covering on the open tailgate or cargo floor surface if the rear closure is a conventional door type tailgate, at the zero "Y" plane.

L202 **CARGO LENGTH-CLOSED-FRONT**. The minimum dimension measured horizontally from the back of the front seat at the height of the undepressed floor covering to the rearmost point on the undepressed floor covering on the closed tailgate or taildoor for station wagons, trucks and mpv's at the zero "Y" plane.

L203 **CARGO LENGTH-CLOSED-SECOND**. The dimension measured horizontally from the back of the second seat at the height of the undepressed floor covering to the rearmost point on the undepressed floor covering on the closed tailgate or taildoor for station wagons, trucks and mpv's at the zero "Y" plane.

L204 **CARGO LENGTH AT BELT-FRONT**. The minimum dimension measured horizontally from the back of the front seatback at the seatback top to the foremost normal surface of the closed tailgate or inside surface of the cab backpanel at the height of the belt, on the zero "Y" plane.

L205 **CARGO LENGTH AT BELT-SECOND**. The minimum dimension measured horizontally from the back of the second seatback top to the foremost normal surface of the closed tailgate at the height of the belt, on the zero "Y" plane.

W201 **CARGO WIDTH-WHEELHOUSE**. The minimum dimension measured laterally between the trimmed wheelhouses at floor level. For any vehicle not trimmed, measure to the sheet metal.

W203 **REAR OPENING WIDTH AT FLOOR**. The minimum dimension measured laterally between the limiting interferences of the rear opening at floor level.

W204 **REAR OPENING WIDTH AT BELT**. The minimum dimension measured laterally between the limiting interferences of the rear opening at belt height or top of pick up box.

W205 **REAR OPENING WIDTH ABOVE BELT**. The minimum dimension measured laterally between the limiting interferences of the rear opening above the belt height.

W500 **CARGO WIDTH AT FLOOR**. The maximum dimension measured laterally between the limiting interferences at the floor level. This dimension shall include ribs and pillars, but will exclude wheelhouses.

H197 **FRONT SEATBACK TO LOAD FLOOR HEIGHT**. The dimension measured vertically from the horizontal tangent to the top of the seatback to the undepressed floor covering.

H201 **CARGO HEIGHT**. The dimension measured vertically from the top of the undepressed floor covering to the headlining at the rear wheel "X" coordinate on the zero "Y" plane.

H202 **REAR OPENING HEIGHT**. The dimension measured vertically from the top of the undepressed floor covering to the upper trimmed opening on the zero "Y" plane with rear door fully open.

H250 **TAILGATE TO GROUND CURB MASS (WT.)** The dimension measured vertically from the top of the undepressed floor covering on the lowered tailgate to ground on the zero "Y" plane.

H505 **MAXIMUM CARGO HEIGHT**. The maximum vertical dimension rear of the front seat from the cargo floor to roof bow or headlining at the zero "Y" plane.

AAMA Specifications

METRIC (U. S. Customary)

Interior Vehicle And Body Dimensions - Key Sheet

Dimensions Definitions

<p>V2 STATION WAGON Measured in inches:</p> $\frac{W4 \times H201 \times L204}{1728} = \text{ft.}^3$ <p>Measured in mm:</p> $\frac{W4 \times H201 \times L204}{10^9} = \text{m}^3(\text{cubicmeter})$	<p>L208 CARGO LENGTH AT FRONT SEATBACK HEIGHT. The minimum horizontal dimension from the "X" plane tangent to the rearmost surface of the driver's seatback to the inside limiting interference of the hatchback door on the vehicle zero "Y" plane.</p> <p>L209 CARGO LENGTH AT FLOOR-FRONT. The minimum horizontal dimension measured at floor level from the rear of the front seatback to the normal limiting interference of the hatchback door on the vehicle zero "Y" plane.</p> <p>L210 CARGO LENGTH AT SECOND SEATBACK HEIGHT. The minimum dimension measured from the "X" plane tangent to the rearmost surface of second seatback or the load floor which is towed at least one half of the H198 dimension height above the rear load floor, to the rearmost inside limiting interference on the zero "X" plane.</p> <p>L211 CARGO LENGTH AT FLOOR-SECOND SEATBACK. The minimum horizontal dimension measured at floor level from the rear of the second seatback or load floor panel to the normal limiting interference of the hatchback door on the vehicle zero "Y" plane.</p> <p>H197 FRONT SEATBACK TO LOAD HEIGHT. The dimension measured vertically from the horizontal tangent to the top of the seatback to the undepressed floor covering.</p> <p>H198 SECOND SEATBACK TO LOAD FLOOR HEIGHT. The dimension measured vertically from the second seatback to the undepressed floor covering.</p> <p>V3 TRUCKS AND MPV'S WITH CLOSED AREA. Measured in inches:</p> $\frac{L204 \times W500 \times H505}{1728} = \text{ft.}^3$ <p>Measured in mm:</p> $\frac{L204 \times W500 \times H505}{10^9} = \text{m}^3(\text{cubicmeter})$
<p>V4 HIDDEN LUGGAGE CAPACITY-REAR OF FRONT SEAT. The total volumes of individual pieces of one set of standard luggage stowed in any hidden cargo area below the load floor rear of the front seat.</p> <p>V5 TRUCKS AND MPV'S WITH OPEN AREA. Measured in inches:</p> $\frac{L506 \times W505 \times H503}{1728} = \text{ft.}^3$ <p>Measured in mm:</p> $\frac{L506 \times W500 \times H503}{10^9} = \text{m}^3(\text{cubicmeter})$	<p>V4 HIDDEN LUGGAGE CAPACITY-REAR OF SECOND SEAT. The total volume of individual pieces of one set of standard luggage stowed in any hidden cargo area below the load floor rear of the second seat.</p> <p>V10 STATION WAGON CARGO VOLUME INDEX. Measured in inches:</p> $\frac{H201 \times L205 \times \frac{W4+W201}{2}}{1728} = \text{ft.}^3$ <p>Measured in mm:</p> $\frac{H201 \times L205 \times \frac{W4+W201}{2}}{10^9} = \text{m}^3(\text{cubicmeter})$
<p>V6 TRUCKS AND MPV'S WITH CLOSED AREA. Measured in inches:</p> $\frac{L204 \times W500 \times H505}{1728} = \text{ft.}^3$ <p>Measured in mm:</p> $\frac{L204 \times W500 \times H505}{10^9} = \text{m}^3(\text{cubicmeter})$	<p>V3 HATCHBACK. Measured in inches:</p> $\frac{\frac{L208+L209}{2} \times W4 \times H197}{1728} = \text{ft.}^3$ <p>Measured in mm:</p> $\frac{\frac{L208+L209}{2} \times W4 \times H197}{10^9} = \text{m}^3(\text{cubicmeter})$
<p>V8 HIDDEN LUGGAGE CAPACITY-REAR OF SECOND SEAT. The total volume of individual pieces of one set of standard luggage stowed in any hidden cargo area below the load floor rear of the second seat.</p> <p>V10 STATION WAGON CARGO VOLUME INDEX. Measured in inches:</p> $\frac{H201 \times L205 \times \frac{W4+W201}{2}}{1728} = \text{ft.}^3$ <p>Measured in mm:</p> $\frac{H201 \times L205 \times \frac{W4+W201}{2}}{10^9} = \text{m}^3(\text{cubicmeter})$	<p>V4 HIDDEN LUGGAGE CAPACITY-REAR OF FRONT SEAT. The total volumes of individual pieces of one set of standard luggage stowed in any hidden cargo area below the load floor rear of the front seat.</p> <p>V11 HATCHBACK CARGO VOLUME INDEX. Usable luggage (one (1) stand and luggage set) below floor: Measured in inches:</p> $\frac{\frac{L210+L211}{2} \times W4 \times H198}{1728} = \text{ft.}^3$ <p>Measured in mm:</p> $\frac{\frac{L210+L211}{2} \times W4 \times H198}{10^9} = \text{m}^3(\text{cubicmeter})$

Hatchback - Cargo Space Dimensions

All Hatchback cargo dimensions are to be taken with the front seat in full down and rear position, and the rear seat folded down. The hatchback door is in the closed position. (For electronically adjusted seats, see the manufacturer's specifications for Design "H" Point).

AAMA Specifications

METRIC (U. S. Customary)

Index

Subject	Page No.	Subject	Page No.
Alternator	16	Passenger Capacity	1
Axle, Drive, Front, Rear, All Four	2, 9, 10	Passenger Mass Distribution	26
Axle Shafts	10	Pistons	3
Battery	16	Power Brakes	12
Body and Miscellaneous Information	17	Power Engine	2
Brakes-Parking Service	12, 13	Power Steering	14
Camber	15	Power Teams	2
Camshaft	3	Propeller Shaft	10
Capacities		Pumps-Fuel	6
Cooling System	5	Water	5
Fuel Tank	6	Radiator-Cap, Hoses, Core	5
Lubricants		Ratios-Axle, Transaxle	2,9,10
Engine Crankcase	4	Compression	2
Transmission/Transaxle	8,9	Steering	14
Rear Axle	10	Transmission/Transaxle	2,8,9
Carburetor	2,6	Rear Axle	2,10
Caster	15	Regulator-Alternator	16
Climate Control System	19	Restraint System	18
Clutch-Pedal Operated	8	Rims	13
Coil, Ignition	16	Rods-Connecting	4
Connecting Rods	4	Scrub Radius	14
Convenience Equipment	20-21	Seats	17
Cooling System	5	Shock Absorbers, Front & Rear	11
Crankshaft	4	Spark Plugs	16
Cylinders and Cylinder Head	3	Speedometer	15
Diesel Information	4	Springs-Front & Rear Suspension	11
Dimension Definitions		Stabilizer (Sway Bar)-Front & Rear	11
Key Sheet-Exterior	28,31,32	Starting System	16
Key Sheet-Interior	29,30,32,33,34	Steering	14
Electrical System	15,16	Suppression-Ignition, Radio	16
Emission Controls	7	Suspension-Front & Rear	11
Engine-General		Tail Pipe	7
Bore, Stroke, Type	3	Theft Protection	21
Compression Ratio	2	Thermostat, Cooling	5
Displacement	2,3	Tires	13
Firing Order, Cylinder Numbering	3	Toe-In	15
General Information, Power & Torque	2	Torque Converter	9
Intake System	4	Torque-Engine	2,8,9
Power Teams	2	Trailer Towing	21
Exhaust System	7	Transaxle	9
Equipment Availability, Convenience	20	Transmission-Types	2,8,9
Fan, Cooling	5	Transmission-Automatic	2,9
Filters - Engine Oil, Fuel System	4	Transmission-Manual	2,8
Four Wheel Drive	10	Transmission-Ratios	2,8,9
Frame	17	Tread	22
Front Suspension	11	Trunk Cargo Load	1
Front Wheel Drive Unit	10	Trunk Luggage capacity	23
Fuel Economy, EPA	1	Turning Diameter	14
Fuel Injection	6	Unitized Construction	18
Fuel System	6	Universal Joints, Propeller Shaft	10
Fuel Tank	6	Valve System	4
Glass	18	Vehicle Dimensions	
Headlamps	18	Width	22
Headroom-Body	23,24	Length	22
Heights	22	Height	22
Horns	15	Ground Clearance	22
Horsepower-Brake	2	Front Compartment	23
Ignition System	16	Rear Compartment	23
Inflation-Tires	13	Luggage Compartment	23
Interior Volumes	23	Station Wagon-Third Seat	24
Instruments	15	Station Wagon-Cargo Space	24
Legroom	23,24	Hatchback-Cargo Space	24
Lengths	22	Fiducial Marks	25
Leveling,Suspension	11	Voltage Regulator	16
Lifters, Valve	4	Water Pump	5
Linings-Clutch, Brake	8,12	Weights	26,27
Lubrication-Engine Transmission/Transaxle	4,8,9	Wheel Alignment	15
Luggage Compartment	23	Wheelbase	22
Models	1	Wheels & Tires	13
Motor Starting	16	Wheel Spindle	14
Muffler	7	Widths	22
Origin	1	Windshield	18
		Windshield Wiper and Washer	15

