

GENUINE CHEVROLET

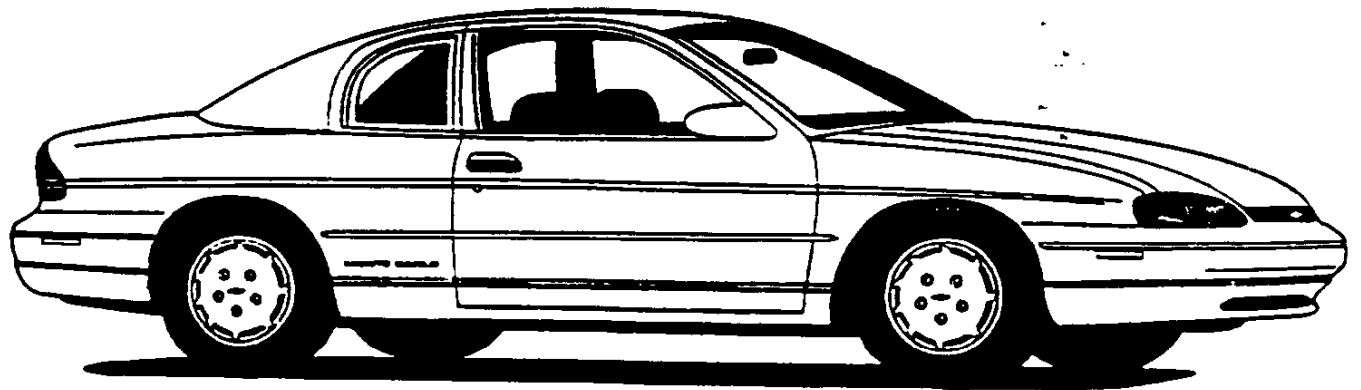

1

2



Monte Carlo

FOCUS: Monte Carlo LS Coupe

'97

Dealer Order Guide inserts are your first look at Chevrolet Passenger Car models for 1997. Overall improvements, changes and deletions are highlighted. Use these inserts to assist you in ordering your initial shipments. (NOTE: some information is preliminary and is subject to change.)

Positioning Statement

A smart, spirited, personal statement you can trust, designed, engineered and built around the driver.

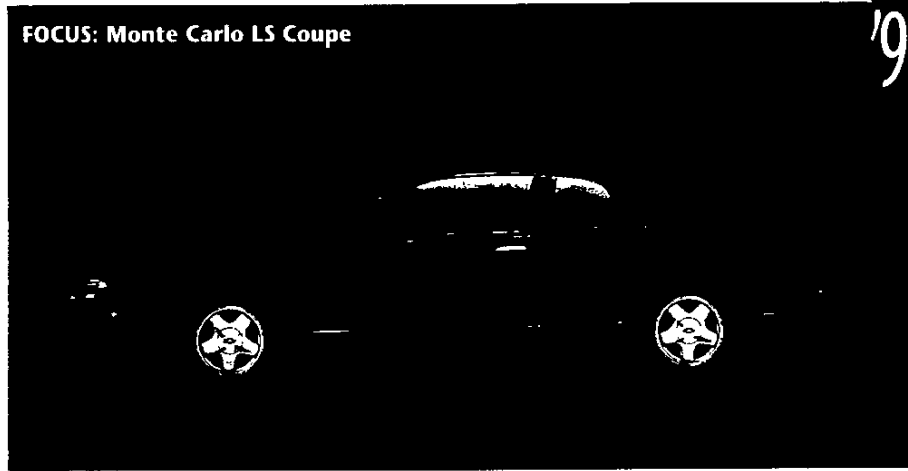

FEATURE: Monte Carlo Z34 Coupe

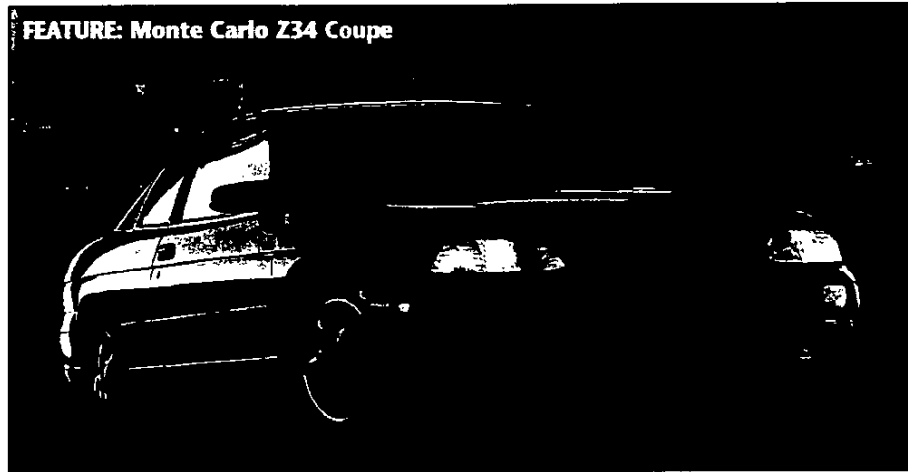

Monte Carlo

FOCUS

Monte Carlo LS Coupe (image above, top)

The Focus vehicle is the model that is chosen for its saleability. It is equipped with the product features that customers want most. Generally, it is the "volume" vehicle that comprises the majority of the build. NOTE: model, PEG and optional equipment may vary in your locality.

The Focus vehicle for 1997 is Monte Carlo LS Coupe. This truly affordable, midsize, 6-passenger coupe offers sleek, contemporary styling teamed with an intelligent combination of standard safety and performance features. When equipped with the recommended PEG 1SG, this model represents the best opportunity for Monte Carlo high-volume sales at your dealership.

Ordering Recommendations: Recommended Monte Carlo LS Coupe content, based on anticipated national sales volume, is listed below to assist your dealership in ordering.

Monte Carlo LS Coupe with Preferred Equipment Group 1SG includes:

Standard Equipment only (see page 4 for details). Individual Options:

- Rear-Window Defogger (C49)
- Aluminum Wheels (PY0), requires QNX tires.
- P225/60R-16 B/W Touring Tires

Evaluate options on an as-needed basis.

Popular colors: Black, Bright White, Dark Jade Green Metallic and Dark Carmine Red Metallic.

FEATURE

The Feature vehicle is the "image" model Chevrolet will profile most in its advertising. Generally, it does the best job of capturing attention and creating consumer awareness.

Monte Carlo Z34 Coupe (image above, bottom)

The Feature vehicle for 1997 is Monte Carlo Z34 Coupe. This powerful, well-appointed sport coupe was designed to please the true automotive enthusiast. Standard features include:

- 3.4 Liter DOHC V6 with Sequential Fuel Injection
- Tuned Ride and Handling Suspension with Fast-Ratio Power Steering
- Analog Instrumentation with Tachometer
- 16" Aluminum Wheels and Goodyear Eagle RS-A Performance Tires specifically designed for Monte Carlo Z34
- Custom Cloth Bucket Seats with Center Storage Armrest and Cup Holder
- Dual Tailpipes
- Dual Remote Body-Color Electric Mirrors.

Lead color: Torch Red.

©1996 All Rights Reserved



7

7





Monte Carlo

'97

S.P.A.C.E. is an acronym that helps organize and explain key features and benefits in the major categories a customer needs and wants. Overall improvements, changes and deletions are highlighted. Please review the supplied information, keeping in mind that this material is provided to you before production startup - and is liable to change.

S.P.A.C.E. (New-for-'97 features appear in color.)



SAFETY

• **AUTOMATIC DAYTIME RUNNING LAMPS** — headlamps automatically come on at low intensity when ignition is turned on, increasing vehicle's visibility to other drivers. Also includes automatic exterior lamp control, which turns on headlamps and all other exterior lamps at full intensity when it's dark outside. System is overridden when driver utilizes headlamps manually. • **4-WHEEL ANTI-LOCK BRAKE SYSTEM (ABS)** — helps reduce wheel lockup and helps driver maintain steering control during severe braking, even on slippery surfaces. 4-wheel disc brakes (standard on Z34) • **DRIVER AND FRONT-PASSENGER AIR BAGS** — help reduce the chance of injury in certain moderate to severe frontal collisions. Always wear safety belts, even with air bags. • **SAFETY-CAGE CONSTRUCTION** — surrounds the entire passenger compartment. • **PASS-KEY II THEFT-DETERRENT SYSTEM** — consists of a small resistance-coded pellet in the ignition key, which must match a measurement circuit in the steering column to enable the engine to start.



PERFORMANCE

• **HANDLING IMPROVEMENTS (LS MODELS ONLY)** — include new diameter for rear stabilizer bar (16mm) and rear springs rate change. • **3100 V6 ENGINE WITH SFI AND 4-SPEED ELECTRONICALLY CONTROLLED AUTOMATIC TRANSMISSION (STANDARD ON LS MODELS)** — delivers smooth, effortless power for passing and merging. Shifts are virtually seamless. • **FOUR-WHEEL INDEPENDENT SUSPENSION** — provides an excellent combination of ride and response. • **3.4 LITER DOHC V6 (Z34 MODELS ONLY)** — four-valves-per-cylinder engine delivers 215 hp at 5200 rpm for impressive performance. New 4-speed electronically controlled transmission comes standard with 3.4 Liter DOHC V6 engine.



APPEARANCE

• **TWO NEW EXTERIOR COLORS** — Dark Jade Green Metallic and Deep Purple Metallic. • **BASECOAT/CLEARCOAT PAINT** — not only provides a more durable, lustrous finish, but reduces the severity of water-spotting and etching from acid rain. • **TWO-SIDE-GALVANIZED STEEL** — on all exterior body panels (except the roof), for unsurpassed corrosion protection.



COMFORT AND CONVENIENCE

• **OPTIONAL ELECTRIC SUNROOF** — provides outside air and sunlight. • **OPTIONAL LEATHER-WRAPPED STEERING WHEEL WITH RADIO CONTROLS** — makes driving more comfortable/stylish, and allows for effortless radio control (standard on Z34). • **SPLIT-FOLDING REAR SEAT** — allows long cargo items to extend from trunk to rear-passenger area. • **OPTIONAL INDIVIDUAL DRIVER AND FRONT-PASSENGER TEMPERATURE CONTROLS** — create more comfortable environment for driver and front-seat passenger.



EASY-TO-OWN

• **SCOTCHGARD™ FABRIC PROTECTOR** — on seats, door panels, floor carpeting and floor mats, resists stains and makes cleanup easy. • **DEXRON III AUTOMATIC TRANSMISSION FLUID** — never needs changing under normal driving conditions. • **PLATINUM-TIP SPARK PLUGS (BOTH ENGINES)** — designed to last up to 100,000 miles.* • **OIL WEAR SENSOR INDICATOR** — informs driver of when it is time to change the engine oil. • **STAINLESS-STEEL EXHAUST SYSTEM** — includes all pipes, catalytic converter and muffler to resist corrosion, for a long service life. • **GENUINE CUSTOMER CARE** — a 3-year/36,000-mile, no deductible, limited warranty, 24-hour roadside assistance via toll-free hot line, and courtesy transportation, if your vehicle ever needs warranty work, at participating dealers.

*Maintenance needs vary with different uses and driving conditions.



4

5



MONTE CARLO

REVISED 8-19-96

1997 ORDER GUIDE

MONTE CARLO

Page 1

Prices Shown Are Manufacturer's Suggested Retail Prices (MSRP) At the Time of Publication. These Prices Are To Be Used Only As An Aid To Inventory Management Since MSRP Figures Change Periodically. The Vehicle Price Schedule Is The Official Pricing Documentation Of Chevrolet Motor Division And Should Be Used In Discussing Vehicle Prices With Potential Buyers. The Model Prices Shown In The Order Guide Include The Destination Freight Charges.



4

4



**MONTE CARLO
TRIM DEFINITION & OPTION SUMMARY**

INTERIOR TRIM		1WW271WX27	
FLOOR COVERING:	MATS, FRONT/REAR FLOOR, CARPETED, COLOR-KEYED	S	S
MIRRORS:	VISOR, LH AND RH	S	S
	VISOR RH ILLUMINATED	S	S
SEATS:	CUSTOM CLOTH 60/40 SEAT WITH CENTER STORAGE ARMREST WITH CUPHOLDER AND 4-WAY MANUAL DRIVER SEAT ADJUSTER AND SPLIT REAR FOLD DOWN	--	S
	CUSTOM CLOTH BUCKET WITH CONSOLE, 4-WAY MANUAL DRIVER SEAT ADJUSTER AND SPLIT REAR FOLD DOWN SEAT	--	S

EXTERIOR TRIM			
MIRRORS:	DUAL BODY COLOR TWIN REMOTE ELECTRIC	--	S
MOLDINGS:	BODYSIDE	S	S
WHEELS:	15" DELUXE BOLT-ON COVERS-SILVER	S	--
	16" ALUMINUM	.	S

MONTE CARLO LS COUPE

COLOR AND TRIM SELECTION

PLEASE NOTE: The Exterior Paint and Interior Trim Combinations Shown Below are the Only Combinations that are Available.

Interior Trim Color	Med Gray	Graphite	Neutral	Med Blue
---------------------	----------	----------	---------	----------

MODEL	SEAT TYPE	SEAT OPT**	14D	12D	52D	30D
1WW27	Custom Cloth 60/40	AM6	14D	12D	52D	30D
	*Custom Cloth Bucket	AR9	14D	12D	52D	30D
	*Leather Bucket	AR9		122	522	

*Includes Console

**Seat Option AM6 or AR9 Must Be Specified

SOLID PAINT APPLICATION

Exterior Paint Color	Color Code	Med Gray	Graphite	Neutral	Med Blue
Black	41U	x	x	x	
Blue, Med Adriatic (Met)	30U	x	x		x
Granite (Met)	03U	x	x	x	
Green, Med Lichen (Met)	47U		x	x	
Green, Dark Jade (Met)	56U	x	x	x	
Purple, Deep (Met)	89U	x	x	x	x
Red, Dk Carmine (Met)	51U	x	x	x	
Red, Torch	70U	x	x	x	
White, Bright	16U	x	x	x	x

POWER TEAMS

ENGINE OPTION CONDITION	FINAL DRIVE RATIO
	3.33
L82 MX0	Std

MONTE CARLO Z34 COUPE

COLOR AND TRIM SELECTION

PLEASE NOTE: The Exterior Paint and Interior Trim Combinations Shown Below are the Only Combinations that are Available.

Interior Trim Color	Med Gray	Graphite	Neutral	Med Blue
---------------------	----------	----------	---------	----------

MODEL	SEAT TYPE	SEAT OPT**				
1WX27	* Custom Cloth Bucket	AR9	14D	12D	52D	30D
	* Leather Bucket	AR9		122	522	

*Includes Console

**Seat Opt AR9 Must Be Specified

SOLID PAINT APPLICATION

Exterior Paint Color	Color Code	Med Gray	Graphite	Neutral	Med Blue
Black	41U	x	x	x	
Blue, Med Adriatic (Met)	30U	x	x		x
Green, Dark Jade (Met)	56U	x	x	x	
Purple, Deep (Met)	89U	x	x	x	
Red, Dk Carmine (Met)	51U	x	x	x	
Red, Torch	70U	x	x	x	
White, Bright	16U	x	x	x	x

POWER TEAMS

ENGINE OPTION CONDITION	FINAL DRIVE RATIO
WITH FE9 FEDERAL EMISSIONS	
LQ1 MX0	Std
WITH YF5 CALIFORNIA EMISSIONS	
LQ1 MX0	Std

MANUFACTURERS MOTOR VEHICLE SPECIFICATIONS

METRIC (U.S. CUSTOMARY)

1997

Manufacturer	CHEVROLET MOTOR DIVISION GENERAL MOTORS CORPORATION	Vehicle Line	MONTE CARLO	
Mailing Address	30007 VAN DYKE WARREN, MI 48090-9065	September, 1996	Revised	

Direct questions concerning these specifications to the manufacturer listed above.

The information contained herein is prepared, distributed by, and is solely the responsibility of the vehicle manufacturing company to whose products it relates. This specification form was developed by the vehicle manufacturing companies under the auspices of the American Automobile Manufacturers Association.

The General Specifications herein are those in effect at date of compilation and are subject to change without notice or incurring obligation by the manufacturer.

AAMA

American Automobile Manufacturers Association

Blank Forms Provided by Technical Affairs Division

Specifications

METRIC

Table of Contents

1	Vehicle Models/Origin	ø	Indicates Format Change
2	Power Teams		From Previous Year
3	Engine		
4	Lubrication System		
4	Diesel System		
5	Cooling System		
6	Fuel System		
7	Vehicle Emission Control		
7	Exhaust System		
8-10	Transmission, Axles and Shafts		
11	Suspension		
12-13	Brakes, Tires and Wheels		
14	Steering		
15-16	Electrical		
17	Body – Miscellaneous Information		
17	Frame		
18	Glass		
18	Headlamps		
19	Climate Control System		
20-21	Convenience Equipment		
21	Trailer Towing		
22-24	Vehicle Dimensions		
25	Vehicle Fiducial Marks		
26	Vehicle Mass		
27	Optional Equipment Differential Mass (Weight)		
28-34	Vehicle Dimensions Definitions – Key Sheets		
35	Index		

NOTE:

1. This form uses both SI Metric units and U.S. Customary units. The metric unit of measure is presented first, and the U.S. Customary unit follows in parentheses.
2. UNLESS OTHERWISE INDICATED:
 - a. Specifications apply to standard models without optional equipment. Significant deviations are noted.
 - b. Nominal design dimensions are used throughout these specifications.
 - c. All linear dimensions are in millimeters (inches), and all mass (weight) specifications are in kilograms (pounds).
3. The General Specifications herein are those in effect at date of compilation and are subject to change without notice or incurring obligation by the manufacturer.
4. Additional Vehicle Dimensions (based in part on SAE J1100 "Motor Vehicle Dimensions") may be available from the manufacturer.

MVMA Specifications

Vehicle Line MONTE CARLO
 Model Year 1997 Issued _____ Revised (●) _____

METRIC (U.S. Customary)

Vehicle Origin

Design & development (company)	G.M., Midsize Car Division
Where built (country)	Canada
Authorized U.S. sales marketing representative	Chevrolet Motor Division

Vehicle Models

Model Description & Drive (FWD / RWD / AWD / 4WD)*	Introduction Date	Make, Vehicle Models, Series, Body Type (Mfg.'s Model Code)	No. of Designated Seating Positions (Front / Rear)	Max. Trunk/Cargo Load-Kilograms (Pounds)	EPA Fuel Economy (City/Hwy)
MONTE CARLO LS 2-Door Notchback Coupe (FWD)		1WW27	6 (3/3) 5 (2/3) Opt.		19/29 - L82
MONTE CARLO Z34 2-Door Notchback Coupe (FWD)		1WX27	5 (2/3)		17/26 - LQ1

MVMA Specifications

Vehicle Line MONTE CARLO
 Model Year 1997 Issued _____ Revised (●) _____

METRIC (U.S. Customary)

Power Teams

SAE J1349 Net bhp (brake horsepower) and Net Torque corrected to 77°F/25°C and 29.61 in. Hg/100 kPa atmospheric pressure.

		A	B	C	D	
E N G I N E	Engine Code	L82	LQ1			
	Displacement Liters (in ³)	3.1 (191)	3.4 (206)			
	Induction system (FI, Carb, etc.)	Sequential Fuel Injection	Sequential Fuel Injection			
	Compression ratio	9.6:1	9.7:1			
	SAE Net at RPM	Power kW (bhp)	119 (160) @ 5200	160 (215) @ 5200		
		Torque N • m (lb. ft.)	251 (185) @ 4000	298 (220) @ 4400		
Exhaust single, dual	Single	Dual				
T R A N S	Transmission/ Transaxle	M13 Auto Transaxle Four-Speed	M15 Auto Transaxle Four-Speed			
	Effective Final Drive / Axle Ratio (std. first)	3.33	3.42			

Series Availability		Power Teams (A - B - C - D)	
Model	Code	Standard	Optional
MONTE CARLO LS			
2-Dr. Notchback Coupe	1VW27	A	-
MONTE CARLO Z34			
2-Dr. Notchback Coupe	1WX27	B	-

MVMA Specifications

Vehicle Line MONTE CARLO
 Model Year 1997 Issued _____ Revised (●) _____

METRIC (U.S. Customary)

Engine Description	3.1 LITER V6 (191 CID)
Engine Code	SEQUENTIAL FUEL INJECTION RPO L82

Engine - General

Type & description (inline, V, angle, flat, location, front, mid, rear, transverse, longitudinal, sohc, dohc, ohv, hemi, wedge, pre-chamber, etc.)	60 Degree V, Transverse, OHV, Front Wheel Drive	
Manufacturer	General Motors Powertrain Group	
No. of cylinders	Six	
Bore	89.0 mm	
Stroke	84.0 mm	
Bore Spacing (C / L to C / L)	111.76 mm	
Cylinder block material & mass kg. (lbs.) (machined)	Cast Iron, 57 (125.7) Block, Bearing Caps, Bolts, & Cup Plug	
Cylinder block deck height	224.0 mm	
Cylinder block length	435.5 mm	
Deck clearance (minimum) (above or below block)	.58 Above TDC	
Cylinder head material & mass kg. (lbs.)	Cast Aluminum, 5.8 (12.8)	
Cylinder head volume cm ³ (inches ³)	26.2 (1.6)	
Cylinder liner material	Not Applicable	
Head gasket thickness (compressed)	1.55 mm	
Minimum combustion chamber total volume cm ³ (inches ³)	60.29 (3.7)	
Cyl. no. system (front to rear)*	L. Bank	2-4-6
	R. Bank	1-3-5
Firing order	1-2-3-4-5-6	
Intake manifold material & mass kg. (lbs.)**	Cast Aluminum, 8.5 (18.7) Upper & lower	
Exhaust manifold material & mass kg. (lbs)**	Cast Iron, Rt: 3.6kg (7.9); Lt: 2.4 (5.3)	
Knock sensor (number & location)	One, Left Side Center of Block	
Fuel required unleaded, diesel, etc.	Unleaded	
Fuel antiknock index (R + M) + 2	86	
Engine Mounts	Quantity	Four
	Material and type (elastomeric, hydroelastic, hydraulic damper, etc.)	One - Hydraulic, One - Elastomeric (Three-Speed Trans.); Two - Hydraulic (Four-Speed Trans.); Two - Torque Struts
	Added isolation (sub-frame, crossmember, etc.)	Isolated Cradle Supporting Left & Right Mounts
Total dressed engine mass (wt) dry***	188 kg with oil	

Engine - Pistons

Material & mass, g (weight, oz.) - piston only	Aluminum Alloy, 0.38 kg
--	-------------------------

Engine - Camshaft

Location	Above Crankshaft at Center of "V"	
Material & mass kg (weight, lbs.)	Assembled Steel, 2.26 (Five)	
Drive type	Chain / belt	Chain
	Width / pitch	16.18 mm Max width; 3/8 pitch inverted Tooth "Silent" Chain

- * Rear of engine - drive takeoff. View from drive takeoff end to determine left & right side of engine.
- ** Finished state.
- *** Dressed engine mass (weight) includes the following: All those items necessary to make the engine a complete ready-to-run unit.

MVMA Specifications

Vehicle Line MONTE CARLO
 Model Year 1997 Issued _____ Revised (●) _____

METRIC (U.S. Customary)

Engine Description **3.4 LITER V6 (207 CID)**
 Engine Code **SEQUENTIAL FUEL INJECTION RPO LQ1**

Engine - General

Type & description (inline, V, angle, flat, location, front, mid, rear, transverse, longitudinal, sohc, dohc, ohv, hemi, wedge, pre-chamber, etc.)	60 Degree V, Front, Transverse, DOHC, Front Wheel Drive	
Manufacturer	General Motors Powertrain Group	
No. of cylinders	Six	
Bore	92.029 mm	
Stroke	84.0 mm	
Bore Spacing (C / L to C / L)	111.76 mm	
Cylinder block material & mass kg. (lbs.) (machined)	Cast Iron, 52.1 (114.9) Block, Bearing Caps, Bolts & Cup Plug	
Cylinder block deck height	224.0 mm	
Cylinder block length	435.5 mm	
Deck clearance (minimum) (above or below block)	0.28 mm Above Block, Nominal (± 0.24 mm)	
Cylinder head material & mass kg. (lbs.)	Aluminum 7.9 (17.4)	
Cylinder head volume cm ³ (inches ³)	50.3 (3.1)	
Cylinder liner material	Not Applicable	
Head gasket thickness (compressed)	1.55 mm	
Minimum combustion chamber total volume cm ³ (inches ³)	67.7 (4.13)	
Cyl. no. system (front to rear)*	L. Bank	2-4-6
	R. Bank	1-3-5
Firing order	1-2-3-4-5-6	
Intake manifold material & mass kg. (lbs.)**	Aluminum, 9.3 (20.4) Upper & Lower	
Exhaust manifold material & mass kg. (lbs)**	Cast Iron - RT: 4.5 (10) LT: 2.9 (6.5)	
Knock sensor (number & location)	Two, Near Starter Motor Under Exhaust Manifold	
Fuel required unleaded, diesel, etc.	Unleaded	
Fuel antiknock index (R + M) + 2	87	
Engine Mounts	Quantity	Four
	Material and type (elastomeric, hydroelastic, hydraulic damper, etc.)	One - Elastomeric; Two - Hydraulic; One - Torque Strut
	Added isolation (sub-frame, crossmember, etc.)	Isolated (Sub-frame) Supporting the Right & Left Hand Mounts
Total dressed engine mass (wt) dry***	237 kg with oil	

Engine - Pistons

Material & mass, g (weight, oz.) - piston only	Aluminum Alloy, 0.41kg
--	------------------------

Engine - Camshaft

Location	(Four) OHC in Carrier	
Material & mass kg (weight, lbs.)	Cast Iron - Left Bank Intake and Exhaust, 4.2 (9.3) Cast Iron - Right Bank Intake and Exhaust, 4.6 (10.1)	
Drive type	Chain / belt	Belt and Chain
	Width / pitch	Belt, 34.0/8.00 mm; Chain, 19.05/9.53 mm

- * Rear of engine - drive takeoff. View from drive takeoff end to determine left & right side of engine.
- ** Finished state.
- *** Dressed engine mass (weight) includes the following: All those items necessary to make the engine a complete ready-to-run unit.



1

2



MVMA Specifications

Vehicle Line MONTE CARLO
 Model Year 1997 Issued _____ Revised (●) _____

METRIC (U.S. Customary)

Engine Description 3.1 LITER V6 (191 CID)
 Engine Code SEQUENTIAL FUEL INJECTION RPO L82

Engine - Valve System

Hydraulic lifters (std., opt., n.a.)	Standard
Valves	Number intake / exhaust
	Head O.D. intake / exhaust
	Six/Six
	43.64 mm / 36.20 mm

Engine - Connecting Rods

Material & mass kg., (weight, lbs.)*	Forged Steel, 0.59 (1.3)
Length (axes C/L to C/L)	144.78 mm

Engine - Crankshaft

Material & mass kg., (weight, lbs.)*	Cast Iron, 17.2 (37.9)
End thrust taken by bearing (no.)	Three
Number & Length of main bearing journals	One - 29.5 mm; Two and Three - 24.0 mm, Four - 36.0 mm
Seal (material, one, two piece design, etc.)	Front
	Rear
	Viton/Steel, One Piece
	Viton/Steel, One Piece

Engine - Lubrication System

Normal oil pressure kPa (psi) at engine rpm	280 - 360 (40.6 - 52.2) @ 2400
Type oil intake (floating, stationary)	Stationary
Oil filter system (full flow, part, other)	Full Flow
Capacity of c/case, less filter-refill-L (qt.)	3.8 (4.0)

Engine - Diesel Information

(NOT APPLICABLE)

Diesel engine manufacturer		
Glow plug, current drain at 0°F.		
Injector nozzle	Type	
	Opening pressure kPa (psi)	
Pre-chamber design		
Fuel Injection pump	Manufacturer	
	Type	
Fuel injection pump drive (belt, chain, gear)		
Supplementary vacuum source (type)		
Fuel heater (yes/no)		
Water separator, description (std., opt.)		
Turbo manufacturer		
Oil cooler-type (oil to engine coolant; oil to ambient air)		
Oil filter		

Engine - Intake System

(NOT APPLICABLE)

Turbo charger - manufacturer	
Super charger - manufacturer	
Intercooler	

* Finished State

4

5

MVMA Specifications

Vehicle Line MONTE CARLO
 Model Year 1997 Issued _____ Revised (●) _____

METRIC (U.S. Customary)

Engine Description
 Engine Code

3.4 LITER V6 (207 CID)
 SEQUENTIAL FUEL INJECTION RPO LQ1

Engine - Valve System

Hydraulic lifters (std., opt., n.a.)	Standard
Valves	Number intake / exhaust
	Head O.D. intake / exhaust

Engine - Connecting Rods

Material & mass kg., (weight, lbs.)*	Forged Steel, 0.59 (1.3)
Length (axes C/L to C/L)	144.78 mm

Engine - Crankshaft

Material & mass kg., (weight, lbs.)*	Nodular Cast Iron, 17.2 (37.9)
End thrust taken by bearing (no.)	Three
number & length of main bearing journals	One - 29.5 mm, Two and Three - 24.0 mm, Four - 36.0 mm
Seal (material, one, two piece design, etc.)	Front
	Rear

Engine - Lubrication System

Normal oil pressure kPa (psi) at engine rpm	275 (40) @ 2000
Type oil intake (floating, stationary)	Stationary
Oil filter system (full flow, part, other)	Full Flow
Capacity of c/case, less filter-refill-L (qt.)	With Optional Oil Cooler 4.73 (5.0), Without Filter

Engine - Diesel Information

(NOT APPLICABLE)

Diesel engine manufacturer	
Glow plug, current drain at 0°F.	
Injector nozzle	Type
	Opening pressure kPa (psi)
Pre-chamber design	
Fuel Injection pump	Manufacturer
	Type
Fuel injection pump drive (belt, chain, gear)	
Supplementary vacuum source (type)	
Fuel heater (yes/no)	
Water separator, description (std., opt.)	
Turbo manufacturer	
Oil cooler-type (oil to engine coolant, oil to ambient air)	
Oil filter	

Engine - Intake System

(NOT APPLICABLE)

Turbo charger - manufacturer	
Super charger - manufacturer	
Intercooler	

* Finished State



4

5



MVMA Specifications

Vehicle Line MONTE CARLO
 Model Year 1997 Issued _____ Revised (●) _____

METRIC (U.S. Customary)

Engine Description	3.1 LITER V6 (191 CID)
Engine Code	SEQUENTIAL FUEL INJECTION RPO L82

Engine - Cooling System

Coolant recovery system (std., opt., n.a.)		Standard	
Coolant fill location (rad., bottle)		Bottle Coolant Recovery	
Radiator cap relief valve pressure kPa (psi)		103.4 (15)	
Circulation thermostat	Type (choke, bypass)	Bypass	
	Starts to open at °C (°F)	90 (195)	
Water pump	Type (centrifugal, other)	Centrifugal	
	GMP 1000 pump rpm	12	
	Number of pumps	One	
	Drive (V-belt, other)	Serpentine	
	Bearing type	Ball-Roller	
	Impeller material	Cast Iron	
Housing material		Aluminum	
By-pass recirculation type (inter., ext.)		External	
Cooling System capacity	With heater - L (qt.)	A/C is Standard	
	With air conditioner - L (qt.)	11.59 (12.2) - Includes 0.5L Reservoir Reserve	
	Opt. equipment specify - L (qt.)	Not Applicable	
Water jackets full length of cyl. (yes, no)		No	
Water all around cylinder (yes, no)		Yes	
Water jackets open at head face (yes, no)		Yes	
Radiator core	Std., A/C, HD	A/C is Standard Equipment	
	Type (cross-flow, etc.)	Cross-Flow	
	Construction (fin & tube mechanical, braze, etc.)	High Efficiency Radiator (H.E.R.), Fin & Tube	
	Material, mass kg (wt., lbs.)	Aluminum, 3.22 (7.16)	
	Width	774.0 mm (30.5 in.)	
	Height	382.4 mm (15.0 in.)	
	Thickness	16.0 mm (0.630 in.)	
Fins per inch		17, 2.5 mm	
Radiator end tank material		Plastic	
Fan	Std., elec., opt.	Electric	Electric
	Number of blades & type (flex, solid, material)	Seven Blades, Solid, Plastic	Seven Blades, Solid, Plastic
	Number & location (front, rear of radiator)	Rear	Rear
	Diameter & projected width	360.0 mm (14.2 in.), Diameter	360.0 mm (14.2 in.), Diameter
	Ratio (fan to crankshaft rev.)	Not Applicable	Not Applicable
	Fan cutout type	ECM Controlled	ECM Controlled
	Drive type (direct, remote)	Direct	Direct
	RPM at idle (elec.)	1800 Primary	1650 Secondary
	Motor rating (wattage/elec.)	150 W	90 W
	Motor switch (type & location/elec.)	Engine Mounted Coolant Temp. Sensor, A/C Liquid Line Press. Switch or Transducer	(Same)
	Switch point (temp./pressure/elec.)	(See Below)	(See Below)
	Fan shroud (material)	Not Available	Not Available

PRIMARY FAN (LH)	ON	OFF	SECONDARY FAN (RH)	ON	OFF
A/C Head Pressure or	190 PSI	140 PSI	A/C Head Pressure or	240 PSI	190 PSI
Engine Coolant	223 deg. F.	216 deg. F.	Engine Coolant	235 deg. F.	228 deg. F.



7

1



MVMA Specifications

Vehicle Line MONTE CARLO
 Model Year 1997 Issued _____ Revised (●) _____

METRIC (U.S. Customary)

Engine Description
 Engine Code

3.4 LITER V6 (207 CID)
 SEQUENTIAL FUEL INJECTION RPO LQ1

Engine - Cooling System

Coolant recovery system (std., opt., n.a.)		Standard	
Coolant fill location (rad., bottle)		Bottle Coolant Recovery	
Radiator cap relief valve pressure kPa (psi)		103.4 (15)	
Circulation thermostat	Type (choke, bypass)	Bypass	
	Starts to open at °C (°F)	90 (194)	
Water pump	Type (centrifugal, other)	Centrifugal	
	GMP 1000 pump rpm	9.7	
	Number of pumps	One	
	Drive (V-belt, other)	Serpentine Poly V	
	Bearing type	Ball-Roller	
	Impeller material	Cast Iron	
Housing material		Aluminum	
By-pass recirculation type (inter., ext.)			
Cooling System capacity	With heater - L (qt.)	A/C is Standard	
	With air conditioner - L (qt.)	11.04 (12.35) - Includes 0.5L Reservoir Reserve	
	Opt. equipment specify - L (qt.)	Not Available	
Water jackets full length of cyl. (yes, no)		No	
Water all around cylinder (yes, no)		Yes	
Water jackets open at head face (yes, no)		Yes	
Radiator core	Std., A/C, HD	A/C is Standard Equipment	
	Type (cross-flow, etc.)	Cross-Flow	
	Construction (fin & tube mechanical, braze, etc.)	High Efficiency Radiator (H.E.R.), Fin & Tube	
	Material, mass kg (wgt., lbs.)	Aluminum, 5.46 (12.04)	
	Width	774.0 mm (30.5 in.)	
	Height	382.4 mm (15.0 in.)	
	Thickness	34 mm (1.3 in.)	
Fins per inch		17, 3.0 mm	
Radiator end tank material		Plastic	
Fan	Std., elec., opt.	Dual Electric Standard	
	Number of blades & type (flex, solid, material)	Seven Blades, Solid, Plastic	Seven Blades, Solid, Plastic
	Number & location (front, rear of radiator)	Rear	Rear
	Diameter & projected width	360.0 mm (14.2 in.), Diameter	360.0 mm (14.2 in.), Diameter
	Ratio (fan to crankshaft rev.)	Not Applicable	Not Applicable
	Fan cutout type	ECM Controlled	ECM Controlled
	Drive type (direct, remote)	Direct	Direct
	RPM at idle (elec.)	2100 Primary	1650 Secondary
	Motor rating (wattage/elec.)	240 W	90 W
	Motor switch (type & location/elec.)	Engine Mounted Coolant Temp. Sensor, A/C Liquid Line Press. Switch or Transducer	(Same)
	Switch point (temp./pressure/elec.)	(See Below)	(See Below)
	Fan shroud (material)	Not Available	Not Available

PRIMARY FAN (LH)	ON	OFF	SECONDARY FAN (RH)	ON	OFF
A/C Head Pressure or	190 PSI	140 PSI	A/C Head Pressure or	240 PSI	190 PSI
Engine Coolant	223 deg. F.	216 deg. F.	Engine Coolant	235 deg. F.	228 deg. F.

MVMA Specifications

Vehicle Line MONTE CARLO
 Model Year 1997 Issued _____ Revised (●) _____

METRIC (U.S. Customary)

Engine Description Engine Code

3.1 LITER V6 (191 CID)
 SEQUENTIAL FUEL INJECTION RPO L82

Engine - Fuel System (See Supplemental page for details of Fuel Injection, Supercharger, Turbocharger, etc. if used.)

Induction type: carburetor, fuel injection system, etc.		Sequential Fuel Injection
Manufacturer		Delphi Energy & Engine Management Systems
Carburetor no. of barrels		Not Applicable
Idle A/F mix.		PCM Controlled
Fuel injection	Point of injection (no.)	Intake Port (Six)
	Constant, pulse, flow	Pulse
	Control (electronic, mech.)	Electronic
	System pressure kPa (psi)	300 (43.5)
Idle speed-rpm (spec. neutral or drive and propane if used)	Manual	Not Applicable
	Automatic	PCM Controlled
Intake manifold heat control (exhaust or water thermostatic or fixed)		Fixed
Air cleaner type		Replaceable Paper Element
Fuel filter (type/location)		Replaceable Enclosed Paper Element (Near Fuel Tank)
Fuel pump	Type (elec. or mech.)	Electrical
	Location (eng., tank)	Tank
	Pressure range kPa (psi)	250-300 (36-44)
	Flow rate at regulated pressure L (gal)/hr @ kPa (psi)	62.4 (16.51) @ 350 (50.8), Figures for Wide Open Throttle

Fuel Tank

Capacity refill L (gallons)		60.9 (16.1)
Location (describe)		Underbody, Forward of Rear Axle
Attachment		Two Steel Straps w/Four Vertical Fasteners
Material & Mass kg. (weight lbs.)		Stamped Steel Upper & Lower w/Perimeter Seam Weld, 9.634 (21.239)
Filler pipe	Location & material	Left Rear Quarter Panel-Steel
	Connection to tank	Flexible Hose
Fuel line (material)		Steel & Nylon
Fuel hose (material)		Nylon
Return line (material)		Steel & Nylon
Vapor line (material)		Steel & Nylon
Extended range tank	Opt., n.a.	Not Applicable
	Capacity L (gallons)	Not Applicable
	Location & material	Not Applicable
	Attachment	Not Applicable
Auxiliary tank	Opt., n.a.	Not Applicable
	Capacity L (gallons)	Not Applicable
	Location & material	Not Applicable
	Attachment	Not Applicable
	Selector switch or valve	Not Applicable
Separate fill		Not Applicable

MVMA Specifications

Vehicle Line MONTE CARLO
 Model Year 1997 Issued _____ Revised (●) _____

METRIC (U.S. Customary)

Engine Description **3.4 LITER V6 (207 CID)**
 Engine Code **SEQUENTIAL FUEL INJECTION RPO LQ1**

Engine - Fuel System (See Supplemental page for details of Fuel Injection, Supercharger, Turbocharger, etc. if used.)

Induction type: carburetor, fuel injection system, etc.		Sequential Fuel Injection
Manufacturer		AC Rochester Products
Carburetor no. of barrels		None
Idle A/F mix.		PCM Controlled
Fuel injection	Point of injection (no.)	At Inlet Ports (Six)
	Constant, pulse, flow	Pulse
	Control (electronic, mech.)	Electronic
	System pressure kPa (psi)	300 (43.5)
Idle speed-rpm (spec. neutral or drive and propane if used)	Manual	Not Applicable
	Automatic	PCM Controlled
Intake manifold heat control (exhaust or water thermostatic or fixed)		Throttle Body Water Heat; No Induction Air Heat
Air cleaner type		Single Snorkel, Replaceable Paper Element
Fuel filter (type/location)		Replaceable Enclosed Paper Element (Near Fuel Tank)
Fuel pump	Type (elec. or mech.)	Electrical
	Location (eng., tank)	Tank
	Pressure range kPa (psi)	250-300 (36-44)
	Flow rate at regulated pressure L (gal)/hr @ kPa (psi)	91.2 (24) @ 350 (51), Figures for Wide Open Throttle

Fuel Tank

Capacity refill L (gallons)		64.7 (17.1)
Location (describe)		Underbody, Forward of Rear Axle
Attachment		Two Steel Straps w/Four Vertical Fasteners
Material & Mass kg. (weight lbs.)		Stamped Steel Upper & Lower w/Perimeter Seam Weld, 9.634 (21.239)
Filler pipe	Location & material	Left Rear Quarter Panel-Steel
	Connection to tank	Flexible Hose
Fuel line (material)		Steel & Nylon
Fuel hose (material)		Nylon (No Coupled Hose)
Return line (material)		Steel & Nylon
Vapor line (material)		Steel & Nylon
Extended range tank	Opt., n.a.	Not Applicable
	Capacity L (gallons)	Not Applicable
	Location & material	Not Applicable
	Attachment	Not Applicable
Auxiliary tank	Opt., n.a.	Not Applicable
	Capacity L (gallons)	Not Applicable
	Location & material	Not Applicable
	Attachment	Not Applicable
	Selector switch or valve	Not Applicable
Separate fill		Not Applicable



;

;



MVMA Specifications

Vehicle Line MONTE CARLO
 Model Year 1997 Issued _____ Revised (●) _____

METRIC (U.S. Customary)

Engine Description 3.1 LITER V6 (191 CID)
 Engine Code SEQUENTIAL FUEL INJECTION RPO L82

Vehicle Emission Control

Type (air injection, engine modifications, other)		Not Applicable		
Exhaust Emission Control	Air injection	Pump or pulse	Not Applicable	
		Driven by	Not Applicable	
		Air distribution (head, manifold, etc.)	Not Applicable	
		Point of entry	Not Applicable	
	Exhaust Gas Recirculation	Type (controlled flow, open orifice, other)	Controlled Flow, Linear	
		Exhaust source	Right Side Exhaust Manifold	
		Point of exhaust injection (spacer, carburetor, manifold, other)	Intake Manifold	
	Catalytic Converter	Type	Three Way Catalyst	
		Number of	One	
		Location(s)	Underbody	
Volume L (in ³)		2.67 (163.0)		
Substrate type		Monolith/Ceramic		
Noble metal type		Platinum (Pt) / Palladium (Pd) / Rhodium (Rh)		
Crankcase Emission Control	Type (ventilates to atmosphere, induction system, other)	Induction System		
		Manifold Vacuum		
	Energy source (manifold vacuum, carburetor, other)	Manifold Vacuum		
		Intake Manifold		
Discharges to (intake manifold, other)	Intake Manifold			
	Right Rear Rocker Arm Cover			
Evaporative Emission Control	Vapor vented to (crankcase, canister, other)	Fuel Tank	Canister	
		Carburetor	Not Applicable	
	Vapor storage provision		Charcoal	
Electronic system	Closed loop (yes/no)	Yes		
	Open loop (yes/no)	No		

Engine - Exhaust System

Type (single, single with cross-over, dual, other)	Single w/Crossover	
○ Muffler no. & type (reverse flow, straight thru, separate resonator) , Muffler volume (liters), Material & Mass kg. (weight lbs.)	Reverse Flow	
○ Resonator no., type, & volume (liters)	88.9 mm O.D., Round Bottle, Straight Thru	
Exhaust pipe	Branch o.d., wall thickness	--
	Main o.d., wall thickness	--
	Material & Mass kg. (weight lbs.)	409 Stainless Steel (Airgap)
Intermediate pipe	o.d. & wall thickness	50.8 x 1.07 mm (2.0 x 0.042 in.)
	Material & Mass kg. (weight lbs.)	409 Stainless Steel
Tail pipe	o.d. & wall thickness	50.8 x 1.07 mm (2.0 x 0.042 in.)
	Material & Mass kg. (weight lbs.)	409 Stainless Steel - Painted Black



MVMA Specifications

Vehicle Line MONTE CARLO
 Model Year 1997 Issued _____ Revised (●) _____

METRIC (U.S. Customary)

Engine Description 3.4 LITER V6 (207 CID)
 Engine Code SEQUENTIAL FUEL INJECTION RPO LQ1

Vehicle Emission Control

Exhaust Emission Control	Air injection	Pump or pulse	Pump
		Driven by	Electric motor
		Air distribution (head, manifold, etc.)	Exhaust manifolds
		Point of entry	Exhaust manifolds
	Exhaust Gas Recirculation	Type (controlled flow, open orifice, other)	Controlled Flow, Linear
		Exhaust source	Right Exhaust Manifold
	Catalytic Converter	Point of exhaust injection (spacer, carburetor, manifold, other)	Intake Manifold
		Type	Three Way Catalyst
		Number of	One
		Locations(s)	Underbody
Volume L (in ³)		2.67 (163.0)	
Substrate type		Ceramic/Monolith	
Crankcase Emission Control	Noble metal type	Platinum (Pt.), Rhodium (Rh), Palladium (Pd)	
	Noble metal concentration (g/cm ³)	0.09/0.0/0.009 (troy oz)	
	Type (ventilates to atmosphere, induction system, other)	Induction System	
	Energy source (manifold vacuum, carburetor, other)	Manifold Vacuum	
Evaporative Emission Control	Discharges to (intake manifold, other)	Inlet Manifold	
	Air inlet (breather cap, other)	Throttle Body	
Electronic system	Vapor vented to (crankcase, canister, other)	Fuel Tank Canister	
		Carburetor Not Applicable	
	Vapor storage provision	Charcoal	
Electronic system	Closed loop (yes/no)	Yes	
	Open loop (yes/no)	No	

Engine - Exhaust System

Type (single, single with cross-over, dual, other)	Dual, w/Crossover	
⊘ Muffler no. & type (reverse flow, straight thru, separate resonator), Muffler volume (liters), Material & Mass kg. (weight lbs.)	Reverse Flow	
⊘ Resonator no., type, & volume (liters)	88.9 mm O.D., Round Bottle, Straight Thru	
Exhaust pipe	Branch o.d., wall thickness	--
	Main o.d., wall thickness	63.5 x 1.77 mm (2.5 x 0.070 in.)
	Material & Mass kg. (weight lbs.)	Laminated 409 Stainless Steel
Intermediate pipe	o.d. & wall thickness	57.2 x 1.37 mm, Legs 50.8 x 1.37 mm
	Material & Mass kg. (weight lbs.)	409 Stainless Steel
Tail pipe	o.d. & wall thickness	57.2 x 1.37 mm, Tip 1.20 mm
	Material & Mass kg. (weight lbs.)	409 Stainless - Steel Painted Black

MVMA Specifications

Vehicle Line MONTE CARLO
 Model Year 1997 Issued _____ Revised (●) _____

METRIC (U.S. Customary)

Engine Description **3.1 LITER V6 (191 CID)**
 Engine Code **SEQUENTIAL FUEL INJECTION RPO L82**

Transmissions/Transaxle (Std., Opt., N.A.)

Manual 4-speed (manufacturer/country)	Not Applicable
Manual 5-speed (manufacturer/country)	Not Applicable
Manual 6-speed (manufacturer/country)	Not Applicable
Automatic (manufacturer/country)	Not Applicable
Automatic overdrive (manufacturer/country)	Gm Powertrain Group, USA

Manual Transmission/Transaxle (NOT APPLICABLE)

Number of forward speeds		
Gear ratios	1st	
	2nd	
	3rd	
	4th	
	5th	
	6th	
	Reverse	
Synchronous meshing (specify gears)		
Shift lever location		
Trans. case material & mass kg. (lbs.)*		
Lubricant	Capacity L (pt.)	
	Type recommended	

Clutch (Manual Transmission) (NOT APPLICABLE)

Clutch manufacturer		
Clutch type (dry, wet; single, multiple disc)		
Linkage (hydraulic, cable, rod, lever, other)		
Max. pedal effort (nom. spring load) N (lbs.)	Depressed	
	Released	
Assist (spring, power/percent, nominal)		
Type pressure plate springs		
Total spring load (nominal) N (lbs.)		
Clutch facing	Facing mfr. & material coding	
	Facing material & construction	
	Rivets per facing	
	Outside x inside dia. (nominal)	
	Total eff. area cm ² (in. ²)	
	Thickness (pressure plate side/fly wheel side)	
	Rivet depth (pressure plate side/fly wheel side)	
Engagement cushion method		
Release bearing type & method lub.		
Torsional damping method, springs, hysteresis		

* Includes shift linkage, lubricant, and clutch housing. If other specify.



MVMA Specifications

Vehicle Line MONTE CARLO
 Model Year 1997 Issued _____ Revised (●) _____

METRIC (U.S. Customary)

Engine Description
 Engine Code

3.4 LITER V6 (207 CID)
 SEQUENTIAL FUEL INJECTION RPO LQ1

Transmissions/Transaxle (Std., Opt., N.A.)

Manual 4-speed (manufacturer/country)	Not Applicable
Manual 5-speed (manufacturer/country)	Not Applicable
Manual 6-speed (manufacturer/country)	Not Applicable
Automatic (manufacturer/country)	Not Applicable
Automatic overdrive (manufacturer/country)	Gm Powertrain Group, USA

Manual Transmission/Transaxle

(NOT APPLICABLE)

Number of forward speeds		
Gear ratios	1st	
	2nd	
	3rd	
	4th	
	5th	
	6th	
	Reverse	
Synchronous meshing (specify gears)		
Shift lever location		
Trans. case material & mass kg. (lbs.)*		
Lubricant	Capacity L (pt.)	
	Type recommended	

Clutch (Manual Transmission)

(NOT APPLICABLE)

Clutch manufacturer		
Clutch type (dry, wet, single, multiple disc)		
Linkage (hydraulic, cable, rod, lever, other)		
Max. pedal effort (nom. spring load) N (lbs.)	Depressed	
	Released	
Assist (spring, power/percent, nominal)		
Type pressure plate springs		
Total spring load (nominal) N (lbs.)		
Clutch facing	Facing mfr. & material coding	
	Facing material & construction	
	Rivets per facing	
	Outside x inside dia. (nominal)	
	Total eff. area cm ² (in. ²)	
	Thickness (pressure plate side/fly wheel side)	
	Rivet depth (pressure plate side/fly wheel side)	
Engagement cushion method		
Release bearing type & method lub.		
Torsional damping method, springs, hysteresis		

* Includes shift linkage, lubricant, and clutch housing. If other specify.



.

.

.

.

.

.

.



MVMA Specifications

Vehicle Line MONTE CARLO
 Model Year 1997 Issued _____ Revised (●) _____

METRIC (U.S. Customary)

Engine Description
 Engine Code

3.1 LITER V6 (191 CID)
 SEQUENTIAL FUEL INJECTION RPO L82

Automatic Transmission/Transaxle

Trade Name		Hydra-Matic 4T60-E (M13) Transaxle
Type and special features (describe)		Four-Speed Automatic w/Torque Converter Clutch
Shift mechanics		Hydraulic Clutches/Electronic Controls
Gear selector	Location (column, floor, other)	Column & Floor (Mechanical)
	Ltr./No. designation (e.g. PRND21)	P-R-N-(<u>OD</u>)-D-2-1
	Shift interlock (yes, no, describe)	Yes - Brake, Ignition Key
Gear ratios	1st	2.92
	2nd	1.57
	3rd	1.00
	4th	0.70
	5th	Not Applicable
	6th	Not Applicable
	Reverse	2.38
	Final drive ratio	3.33
Max. upshift vehicle speed - drive range km/h (mph)		One - Two = 66 (41) Three - Four = 163 (101) Two - Three = 124 (77)
Max. upshift engine speed RPM		5600
Max. kickdown speed - drive range km/h (mph)		Two - One = 48 (30) Three - Two = 104 (65)
Min. overdrive speed km/h (mph)		52 (32)
Torque converter	Type	Lock-Up
	Torus design	Yes
	Number of elements	Three
	Max. ratio at stall	1.95
	Type of cooling (air, liquid)	Liquid
	Nominal diameter	245.0 mm
Capacity factor "K"		180
Pump type		Variable Displacement Vane
Lubricant	Capacity refill L (qts.)	12.7 (13.4) Dry
	Type recommended	Dexron III
Oil cooler (std., opt., N.A., internal, external, air, liquid)		Standard, Integral with Radiator
Transmission mass kg (lbs.) & case material**		81.0 (178.50), Cast Aluminum

All Wheel / 4 Wheel Drive

(NOT APPLICABLE)

Description & type (part-time, full-time, 2/4 shift while moving, mechanical, elect., chair/gear, etc.)		
Transfer case	Manufacturer and model	
	Type and location	
Low-range gear ratio		
System disconnect (describe)		
Center differential	Type (bevel, planetary, w or w/o viscous bias, torsen, etc.)	
	Torque split (% front/rear)	

* Input speed + $\sqrt{\text{torque}}$

** Dry weight including torque converter. If other, specify.



.

.



MVMA Specifications

Vehicle Line MONTE CARLO
 Model Year 1997 Issued _____ Revised (●) _____

METRIC (U.S. Customary)

Engine Description	3.4 LITER V6 (207 CID)
Engine Code	SEQUENTIAL FUEL INJECTION RPO LQ1

Automatic Transmission/Transaxle

Trade Name		Hydra-Matic 4T65E Transaxle
Type and special features (describe)		Four Speed, Front Wheel Drive, Electronically Controlled, Automatic Transaxle with Torque Converter Clutch and Overdrive
Shift mechanics		Hydraulic Clutches/Electronic Controls
Gear selector	Location (column, floor, other)	Floor
	Ltr./No. designation (e.g. PRND21)	P-R-N-(<u>OD</u>)-D-2-1
	Shift interlock (yes, no, describe)	Yes - Brake, Ignition Key
Gear ratios	1st	2.92
	2nd	1.57
	3rd	1.00
	4th	0.71
	5th	Not Applicable
	6th	Not Applicable
	Reverse	2.39
	Final drive ratio	3.05 3.43 Effective
Max. upshift vehicle speed - drive range km/h (mph)		One - Two = 77 (48) Three - Four = 185 (115) Two - Three = 138 (86)
Max. upshift engine speed RPM		6500
Max. kickdown speed - drive range km/h (mph)		Two - One = 59 (37) Three - Two = 122 (76)
Min. overdrive speed km/h (mph)		67 (42)
Torque converter	Type	ECCC
	Torus design	Yes
	Number of elements	Three
	Max. ratio at stall	2.35
	Type of cooling (air, liquid)	Liquid
	Nominal diameter	245 mm (9.7 in.)
Capacity factor "K"		177
Pump type		Variable Displacement Vane
Lubricant	Capacity refill L (pt.)	12.7 (26.6), Dry Transmission
	Type recommended	Dexron III
Oil cooler (std., opt., N.A., internal, external, air, liquid)		Standard, Integral with Radiator
Transmission mass kg (lbs.) & case material**		93 wet, Cast Aluminum

All Wheel / 4 Wheel Drive

(NOT APPLICABLE)

Description & type (part-time, full-time, 2/4 shift while moving, mechanical, elect., chain/gear, etc.)		
Transfer case	Manufacturer and model	
	Type and location	
Low-range gear ratio		
System disconnect (describe)		
Center differential	Type (bevel, planetary, w or w/o viscous bias, torsen, etc.)	
	Torque split (% front/rear)	

* Input speed + $\sqrt{\text{torque}}$

** Dry weight including torque converter. If other, specify.



.

.

.



MVMA Specifications

Vehicle Line MONTE CARLO
 Model Year 1997 Issued _____ Revised (●) _____

METRIC (U.S. Customary)

Engine Description **3.1 LITER V6 (191 CID)**
 Engine Code **SEQUENTIAL FUEL INJECTION RPO L82**

Axle Ratio and Tooth Combinations (See 'Power Teams' for axle ratio usage) (AUTOMATIC TRANS - M13)

Effective final drive ratio (or overall top gear ratio)		3.33 (2.35)
Transfer ratio and method (chain, gear, etc.)		1.00 Chain
Front drive unit	Ring gear o.d.	Not Applicable
	No. of teeth	Not Applicable
	Pinion	Not Applicable
	Ring gear	Not Applicable

Front Drive Unit

Description (integral to trans., etc.)		Planetary Final Drive Integral with Transmission
Limited slip differential (type)		Not Applicable
Drive pinion	Type	Not Applicable
	Offset	Not Applicable
No. of differential pinions		Two
Pinion / differential	Adjustment (shim, etc.)	Not Applicable
	Bearing adjustment	Not Applicable
Driving wheel bearing (type)		
Lubricant	Capacity L (pt.)	8.0 (16.9)
	Type recommended	Dexron II

Axle Shafts - Front Wheel Drive

Manufacturer and number used		Two Per Car		
Type (straight, solid bar, tubular, etc.)	Left	Straight Solid Bar		
	Right	Straight Solid Bar		
Outer diam. x length* x wall thickness	Manual Transaxle	Left	Not Applicable	
		Right	Not Applicable	
	Automatic transaxle	Left	--	
		Right	--	
	Optional transaxle	Left	27.1 x 326.0 mm (1.07 x 12.83 in.)	
		Right	27.1 x 360.0 mm (1.07 x 14.17 in.)	
Slip yoke	Type	--		
	Number of teeth	--		
	Spline o.d.	--		
Universal joints	Make and mfg. no.	Inner	Delphi Saginaw Steering Systems	
		Outer	Delphi Saginaw Steering Systems	
	Number used	Four, Two on Each Shaft		
	Type, size, plunge	Inner	Tripot Joint, 27 Size 66.0 mm Plunge	
		Outer	Rzeppa Joint: Fixed, 27 Size	
	Attach (u-bolt, clamp, etc.)	Inboard Joint - Snap Ring, Outboard Joint (Nut/Washer - Clamping)		
	Bearing	Type (plain, anti-friction)	Inboard Joint: Ball Bearing, Needle Roller Bearing (Anti-Friction Bearing) Outboard Joint: Ball Bearing	
Lubrication (fitting, prepack)		Prepacked		
Drive taken through (torque tube, arms or springs)		Wishbone Lower Control Arm, Upper Macpherson Strut		
Torque taken through (torque tube, arms or springs)		Engine Mounting System		

* Centerline to centerline of universal joints, or to centerline of attachment.



.

.

.

.

.

.



MVMA Specifications

Vehicle Line MONTE CARLO
 Model Year 1997 Issued _____ Revised (●) _____

METRIC (U.S. Customary)

Engine Description
 Engine Code

3.4 LITER V6 (207 CID)
 SEQUENTIAL FUEL INJECTION RPO LQ1

Axle Ratio and Tooth Combinations (See 'Power Teams' for axle ratio usage)

Effective final drive ratio (or overall top gear ratio)		3.43 (2.41)
Transfer ratio and method (chain, gear, etc.)		
Front drive unit	Ring gear o.d.	
	No. of teeth	Pinion
		Ring gear

Front Drive Unit

Description (integral to trans., etc.)		Integral to Transmission
Limited slip differential (type)		Not Applicable
Drive pinion	Type	Not Applicable
	Offset	Not Applicable
No. of differential pinions		Two
Pinion / differential	Adjustment (shim, etc.)	Not Applicable
	Bearing adjustment	Not Applicable
Driving wheel bearing (type)		Sealed Ball Bearing
Lubricant	Capacity L (pt.)	
	Type recommended	

Axle Shafts - Front Wheel Drive

Manufacturer and number used		Delphi Saginaw Steering Systems	
Type (straight, solid bar, tubular, etc.)		Left	Straight Solid Bar
		Right	Straight Solid Bar
Outer diam. x length* x wall thickness	Manual Transaxle	Left	Not Applicable
		Right	Not Applicable
	Automatic transaxle	Left	27.1 x 326 mm (1.07 x 12.83 in.)
		Right	27.1 x 360 mm (1.07 x 14.17 in.)
	Optional transaxle	Left	Not Available
		Right	Not Available
Slip yoke	Type	Not Applicable	
	Number of teeth	Not Applicable	
	Spline o.d.	Not Applicable	
Universal joints	Make and mfg. no.	Inner	Delphi Saginaw Steering Systems
		Outer	Delphi Saginaw Steering Systems
	Number used		Inboard & Outboard on Each Shaft Assembly
	Type, size, plunge	Inner	Tripot Joint, 27 Size 66.0 mm Plunge
		Outer	Rzeppa Joint, Fixed Center, 27 Size
	Attach (u-bolt, clamp, etc.)		Retaining Ring
	Bearing	Type (plain, anti-friction)	Inner - Ball & Roller Outer - Ball
Lubrication (fitting, prepack)		Prepacked	
Drive taken through (torque tube, arms or springs)		Wishbone Lower Control Arm, Upper MacPherson Strut	
Torque taken through (torque tube, arms or springs)		Engine Mounting System	

* Centerline to centerline of universal joints, or to centerline of attachment.



.

.



MVMA Specifications

Vehicle Line MONTE CARLO
 Model Year 1997 Issued _____ Revised (●) _____

METRIC (U.S. Customary)

Model Code/Description And/Or
 Engine Code/Description

COUPE (EXCEPT 3.4L ENGINE) (FE1 SUSPENSION)

Suspension - General Including Electronic Controls

Car leveling	Standard/optional/not available		Not Available	
	Manual/automatic control		Not Available	
	Type (air/hydraulic)		Not Available	
	Primary/assist spring		Not Available	
	Rear only/4 wheel leveling		Not Available	
	Single/dual rate spring		Not Available	
	Single/dual ride heights		Not Available	
	Provision for jacking		Body Rails, Under Rocker Panels; Jack Pad at Center of Rear Crossmember	
Shock absorber damping controls	Standard/option/not available		Not Available	
	Manual/automatic control		Not Available	
	Number of damping rates		Not Available	
	Type of actuation (manual/ electric motor/air, etc.)		Not Available	
	Sensors	Lateral acceleration		Not Available
		Deceleration		Not Available
		Acceleration		Not Available
Road surface		Not Available		
Shock absorber (front & rear)	Type		MacPherson Strut Front, MacPherson Strut Rear	
	Make		Delphi Chassis Systems	
	Piston diameter		35.0 mm (1.38 in.)	
	Rod diameter		25.0 mm (1.00 in.)	

Suspension - Front

Type and description		MacPherson Strut with Coil Springs, One-Piece "A" Configuration Lower Control Arms	
Travel	Full jounce (define load condition)	78.0 mm (3.07 in.)	
	Full rebound	95.0 mm (3.74 in.)	
Spring	Type (coil, leaf, other & material)		Coil
	Insulators (type & material)		Rubber
	Size (Leaf: length & width; Coil: design height & i.d.; Bar: length & diameter)		Coil: 200.3 mm (7.89 in.); 173.0 mm (6.81 in.)
	Spring rate N/mm (lb./in.)		19.5 (111.4)
	Rate at wheel N/mm (lb./in.)		24.0 (137.1)
Stabilizer	Type (link, linkless, frameless)		Linkless
	Material & O.D. bar/tube, wall thickness		Steel, 30.0 mm (1.18 in.) - Solid

Suspension - Rear

Type and description		Tri-Link Independent MacPherson Strut with Coil Springs Lateral Links Attached to Body Cross Member, Trailing Arms	
Travel	Full jounce (define load condition)	102.0 mm (4.02 in.)	
	Full rebound	105.0 mm (4.13 in.)	
Spring	Type (coil, leaf, other & material)		Coil
	Size (Leaf: length & width; Coil: design height & i.d.; Bar: length & diameter)		Coil: 224.0 mm (8.8 in.); 137.0 mm (5.4 in.)
	Spring rate N/mm (lb./in.)		16.0 / 40.5 Variable Rate
	Rate at wheel N/mm (lb./in.)		TBD
	Insulators (type & material)		Rubber
	if leaf	No. of leaves	-
		Shackle (comp. or tens.)	-
Stabilizer	Type (link, linkless, frameless)		Link
	Material & O.D. bar/tube, wall thickness		Steel, 20.0 mm (0.787 in.) Solid
Track bar (type)		Not Applicable	



.

.

.

.



MVMA Specifications

Vehicle Line MONTE CARLO
 Model Year 1997 Issued _____ Revised (●) _____

METRIC (U.S. Customary)

Model Code/Description And/Or
 Engine Code/Description

COUPE (3.4L DOHC ENGINE) (F41 SUSPENSION)

Suspension - General Including Electronic Controls

Car leveling	Standard/optional/not available		Not Available	
	Manual/automatic control		Not Available	
	Type (air/hydraulic)		Not Available	
	Primary/assist spring		Not Available	
	Rear only/4 wheel leveling		Not Available	
	Single/dual rate spring		Not Available	
	Single/dual ride heights		Not Available	
	Provision for jacking		Body Rails, Under Rocker Panels; Jack Pad at Center of Rear Crossmember	
Shock absorber damping controls	Standard/option/not available		Not Available	
	Manual/automatic control		Not Available	
	Number of damping rates		Not Available	
	Type of actuation (manual/electric motor/air, etc.)		Not Available	
	Sensors	Lateral acceleration		Not Available
		Deceleration		Not Available
		Acceleration		Not Available
Road surface		Not Available		
Shock absorber (front & rear)	Type		MacPherson Strut Front, Tubular Rear	
	Make		Delphi Chassis Systems	
	Piston diameter		35.0 mm (1.38 in.)	
	Rod diameter		25.0 mm (1.00 in.)	

Suspension - Front

Type and description		MacPherson Strut with Coil Springs, One-Piece "A" Configuration Lower Control Arms	
Travel	Full jounce (define load condition)	78.0 mm (3.07 in.)	
	Full rebound	95.0 mm (3.74 in.)	
Spring	Type (coil, leaf, other & material)		Coil
	Insulators (type & material)		Rubber
	Size (Leaf: length & width; Coil: design height & i.d.; Bar: length & diameter)		Coil: 200.3 mm (7.89 in.); 173.0 mm (6.81 in.)
	Spring rate N/mm (lb./in.)		23.5 (134.2)
	Rate at wheel N/mm (lb./in.)		26.8 (153.0)
Stabilizer	Type (link, linkless, frameless)		Linkless
	Material & O.D. bar/tube, wall thickness		Steel, 34.0 mm (1.34 in.) - Hollow (Wall Thickness = 5.1 mm)

Suspension - Rear

Type and description		Tri-Link Independent MacPherson Strut with Coil Springs Large Lateral Links Attached to Body Cross Member, Trailing Arms	
Travel	Full jounce (define load condition)	102.0 mm (4.02 in.)	
	Full rebound	105.0 mm (4.13 in.)	
Spring	Type (coil, leaf, other & material)		Coil
	Size (Leaf: length & width; Coil: design height & i.d.; Bar: length & diameter)		Coil: 224.0 mm (8.8 in.); 137.0 mm (5.4 in.)
	Spring rate N/mm (lb./in.)		18.5 / 33.3 Variable Rate
	Rate at wheel N/mm (lb./in.)		TBD
	Insulators (type & material)		Rubber
	If leaf	No. of leaves	--
		Shackle (comp. or tens.)	--
Stabilizer	Type (link, linkless, frameless)		Link
	Material & O.D. bar/tube, wall thickness		Steel, 22.0 mm (0.866 in.) Solid
Track bar (type)		Not Applicable	



.

.



MVMA Specifications

Vehicle Line MONTE CARLO
 Model Year 1997 Issued _____ Revised (●) _____

METRIC (U.S. Customary)

Model Code/Description And/Or
 Engine Code/Description

COUPE

Brakes - Service

Description		Dual Piston Caliper - Front Disc; Single Piston Caliper - Rear Disc			
Manufacturer and brake type (std., opt., n.a.)	Front (disc or drum)	Disc			
	Rear (disc or drum)	Disc			
Valving type (proportion, delay, metering, other)		Proportioning			
Power brake (std., opt., n.a.)		Standard			
Booster type (remote, integral, vac., hyd., etc.)		Vacuum			
Vacuum	Source (inline, pump, etc.)	Inline			
	Reservoir (volume in. ³)	Not Applicable			
	Pump-type (elec., gear or belt driven)	Not Applicable			
Traction assist	Operational speed range	Not Applicable			
	Type (engine or brake intervention)	Not Applicable			
Antilock device	Front/rear (std., opt., n.a.)	Standard - All Models			
	Manufacturer	Delphi Saginaw Steering Systems			
	Type (electronic, mech.)	Electronic			
	Number sensors or circuits	Four			
	Number antilock hydraulic circuits	Four Separate Brake Lines/Three Controlled Channels (LF, RF, RR)			
	Integral or add-on system	Add-On Mounted to Master Cylinder			
	Yaw control (yes, no)	Yes			
Hyd. power source (elec., vac., mtr., pwr., strg.)		Not Applicable			
Effective area cm ² (in. ²)*		283.9 (44.0), Four Wheels			
Gross Lining area cm ² (in. ²)** (F/R)		F: 167.7 (26.0); R: 116.1 (18.0)			
Swept area cm ² (in. ²)** (F/R)		F: 1090.9 (169.09); R: 926.4 (143.6)			
Rotor	Outer working diameter	F/R	F: 267.0 mm (10.5 in.);		
	Inner working diameter	F/R	F: 167.0 mm (6.6 in.);		
	Thickness	F/R	F: 26.3 mm (1.04 in.);		
	Material & type (vented/solid)	F/R	F: Composite Vented;		
Drum	Diameter & width	F/R	Not Applicable		
	Type and material	F/R	Not Applicable		
Wheel cylinder bore		F: 42.0 mm (1.65 in.)			
Master cylinder	Bore/stroke	F/R	Bore: 24.0 mm (0.94 in.); Stroke: 35.5 mm (1.40 in.)		
Pedal arc ratio		3.5:1			
Line press. at 445 N (100 lb.) pedal load [kPa (psi)]		13600 kPa (1972 psi)			
Lining clearance		F/R	0/0 mm		
Brake lining	Front wheel	Bonded or riveted (rivets/seg.)		Integrally Molded	
		Rivet Size		--	
		Manufacturer		Delphi Chassis Systems	
		Lining code *****		DM127EE	
		Material		Semi-Metallic	
		****	Primary or out-board	119.4 x 38.1 mm / (4.7 x 1.5 in.)	
		Size	Secondary or in-board	119.4 x 38.1 mm / (4.7 x 1.5 in.)	
	Shoe thickness (no lining)		4.98 mm (0.196 in.)		
	Rear wheel	Bonded or riveted (rvts/seg.)		Integrally Molded	
		Manufacturer		Delco Chassis Division	
		Lining code *****		DM127EE	
		Material		Semi-Metallic	
		****	Primary or out-board	83.8 x 33.0 mm / (3.3 x 1.3 in.)	
		Size	Secondary or in-board	102.9 x 33.0 mm / (4.05 x 1.3 in.)	
Shoe thickness (no lining)		4.98 mm (0.196 in.)			

* Excludes rivet holes, grooves, chamfers, etc. ** Includes rivet holes, grooves, chamfers, etc.
 *** Total swept area for four brakes. (Drum brake: Widest lining contact width for each brake x its contact circumference.)
 (Disc brake: Square of Outer Working Dia. minus Square of inner Working Dia. multiplied by $\pi/2$ for each brake.)
 **** Size for drum brakes includes length x width x thickness. ***** Manufacturer I.D., catalog for formulation designation and coefficient of friction classification.



.

.



MVMA Specifications

Vehicle Line MONTE CARLO
 Model Year 1997 Issued _____ Revised (●) _____

METRIC (U.S. Customary)

Model Code/Description And/Or
 Engine Code/Description

COUPE

Tires And Wheels (Standard)

Tires	Size (service description)		P205/70R15 AL2 BW (95 S)
	Type (bias, radial, steel, nylon, etc.)		Steel Belted Radial (Two Ply)
	Inflation pressure (cold) for recommended max. vehicle load	Front kPa (psi)	205 (30)
		Rear kPa (psi)	205 (30)
	Rev./mile at 70 km/h (45 mph)		492 Rev/Km
Wheels	Type & material		Stamped Steel
	Rim (size & flange type)		15 x 6
	Wheel offset		42.0 mm (1.65 in.)
	Attachment	Type (bolt or stud & nut)	Stud (M12 x 1.5)
		Circle diameter	115 mm (4.52 in.)
Number & size		Five & M12	
Spare	Tire and wheel		Compact Spare T125/70D16 16 x 4 Wheel
	Storage position & location (describe)		Horizontal, Under Trunk Compartment Load Floor

Tires And Wheels (Optional)

Tire size (service description)		P215/65R15 - Police
Type (bias, radial, steel, nylon, etc.)		Steel Belted Radial
Wheel (type & material)		Stamped Steel
Rim (size, flange type and offset)		15 x 6 (42.0 mm Offset)
Tire size (service description)		
Type (bias, radial, steel, nylon, etc.)		
Wheel (type & material)		
Rim (size, flange type and offset)		
Tire size (service description)		P225/60R16 AL2 BW (97 S)
Type (bias, radial, steel, nylon, etc.)		Steel Belted Radial
Wheel (type & material)		Cast Aluminum
Rim (size, flange type and offset)		16 x 6.5 (38.0 mm Offset)
Tire size (service description)		P225/60R16 - AL3 BL - Z34 (97 H)
Type (bias, radial, steel, nylon, etc.)		Steel Belted Radial
Wheel (type & material)		Cast Aluminum
Rim (size, flange type and offset)		16 x 6.5 (38.0 mm Offset)
Spare tire and wheel size		
(if configuration is different than road tire or wheel, describe optional spare tire and/or wheel location & storage position)		

Brakes - Parking

Type of control		Single Stroke, Foot Pedal Application, Push to Release
Location of control		Left of Driver's Left Knee
Operates on		Rear Service Brakes
If separate from service brakes	Type (internal or external)	--
	Drum diameter	--
	Lining size (length x width x thickness)	--



.

.

.

.

.

.



MVMA Specifications

Vehicle Line MONTE CARLO
 Model Year 1997 Issued _____ Revised (●) _____

METRIC (U.S. Customary)

Model Code/Description And/Or
 Engine Code/Description

COUPE

Steering

Manual (std., opt., n.a.)		Not Available		
Power (std., opt., n.a.)		Standard		
Speed-sensitive (std., opt., n.a.)		Not Available		
4-wheel steering (std., opt., n.a.)		Not Available		
Adjustable steering wheel/column (tilt, telescope, other)	Type	Tilt		
	Manufacturer	Delphi Saginaw Steering		
	(std., opt., n.a.)	Standard		
Wheel diameter** (W9) SAE J1100	Manual	Not Available		
	Power	380.0 mm		
Turning diameter m (ft.)	Outside front	Wall to wall (l. & r.)	Coupe: FE1 - 12.93 (42.42); F41/FE2 - 13.58 (44.55); FE3 - 13.60 (44.60)	
		Curb to curb (l. & r.)	FE1 - 11.2 (36.7); F41 - 11.88 (39.0); FE2 - 11.88 (39.0); FE3 - 11.88 (39.0)	
	Inside rear	Wall to wall (l. & r.)	Not Available	
		Curb to curb (l. & r.)	7.18 (23.6)	
Scrub Radius*		Base - 15.78 mm; Touring - 16.39; Sport - 24.05 mm		
Manual	Gear	Type	Not Available	
		Manufacturer	Not Available	
		Ratios	Gear	Not Available
			Overall	Not Available
No. wheel turns (stop to stop)		Not Available		
Power	Type (coaxial, elec. hyd., etc.)		Hydraulic	
	Manufacturer		Saginaw Division	
	Gear	Type	End Take-Off Rack and Pinion	
		Ratios	Gear	49.9 mm/Rev
			Overall	16.1:1
	Pump (drive)		Belt	
No. wheel turns (stop to stop)		P205/70R15-2.60 (FE1) P225/60R16-2.26 (F41)		
Linkage	Type		End Take-Off	
	Location (front or rear of wheels, other)		Rear	
	Tie rods (one or two)		Two	
Steering axis	Inclination at camber (deg.)		13.4	
	Bearings (type)	Upper	Ball Bearing	
		Lower	Ball Joint	
		Thrust	Not Applicable	
Steering spindle/knuckle & joint type		MacPherson Strut		

* The horizontal distance in the front elevation between wheel centerline and kingpin (ball joint) axis at ground.
 ** See Page 23.



•

•

•



MVMA Specifications

Vehicle Line MONTE CARLO
 Model Year 1997 Issued _____ Revised (●) _____

METRIC (U.S. Customary)

Model Code/Description And/Or
 Engine Code/Description

COUPE

Wheel Alignment

Front wheel at curb mass (wt.)	Service checking	Caster (deg.)	1.8 ± 0.5	
		Camber (deg.)	0.7 ± 0.5	
		Toe-in outside track mm (in.)	0.0 ± 0.20	
	Service reset*	Caster (deg.)	Pre-set	
		Camber (deg.)	0.7	
		Toe-in mm (in.)	0.0	
Periodic M.V. in-spection	Caster (deg.)			
	Camber (deg.)			
	Toe-in mm (in.)			
Rear wheel at curb mass (wt.)	Service checking	Camber (deg.)	15" Whl. -0.35 ± 0.5	16" Whl. -0.45 ± 0.5
		Toe-in outside track (deg.)	0.0 ± 0.3 (Sum Toe)	
	Service reset*	Camber (deg.)	15" Whl. -0.35 ± 0.5	16" Whl. -0.45 ± 0.5
		Toe-in (deg.)	0.0 ± 0.3 (Sum Toe)	
	Periodic M.V. insp.	Camber (deg.)		
		Toe-in mm (in.)		

* Indicates pre-set, adjustable, trend set or other.

Electrical - Instruments and Equipment

Speedometer	Type (analog, digital, std., opt.)	Analog
	Trip odometer (std., opt., n.a.)	Not Available
Head-up display	Standard, optional, not available	Not Available
	Type	Secondary, opto-electronic
	Speedometer	Digital
	Status/warning indicators	Turn signals, high beam, low fuel, check gauges
	Brightness control	Day / night mode, adjustable
EGR maintenance indicator		Not Available
Charge indicator	Type	Not Available
	Warning device (light, audible)	Tell-Tale Light
Temperature indicator	Type	Not Available
	Warning device (light, audible)	Tell-Tale Light
Oil pressure indicator	Type	Not Available
	Warning device (light, audible)	Tell-Tale Light
Fuel indicator	Type	Analog
	Warning device (light, audible)	Not Available
Windshield wiper	Type (standard)	Depressed Park / Pulse Wiper
	Type (optional)	Not Available
	Blade length	560.0 mm (22.0 in.)
	Swept area cm ² (in. ²)	7558.3 (1171.5)
Windshield washer	Type (standard)	Wet-Arm System
	Type (optional)	Not Available
	Fluid level indicator (light, audible)	Not Available
Rear window wiper, wiper/washer (std., opt., n.a.)		Not Available
Horn	Type	Vibrator
	Number used	Two
Other	PRNDL	Mechanical
	Odometer	Mechanical
	Tachometer	Not Available



•

•

•

•

•

•

•

•

•



MVMA Specifications

Vehicle Line MONTE CARLO
 Model Year 1997 Issued _____ Revised (●) _____

METRIC (U.S. Customary)

Engine Code/Description

3.1 LITER V6 (191 CID)
 SEQUENTIAL FUEL INJECTION RPO L82

Electrical - Supply System

Battery	Manufacturer	Delphi Energy & Engine Management Systems
	Model, std., (opt.)	SAE 75-525 (1983655)
	Voltage	12
	Amps at 0° F. cold crank	525
	Minutes-reserve capacity	90
	Amps/hrs. -20 hr. rate	54
	Location	Engine Compartment
Alternator	Manufacturer	Delphi Energy & Engine Management Systems
	Rating (idle/max. rpm)	36/100 Amps
	Ratio (alt. crank/rev.)	2.75
	Output at idle (rpm, park)	68 Amps W/AC
	Optional (type & rating)	Not Applicable
Regulator	Type	Integral with Alternator

Electrical - Starting System

Motor	Manufacturer	Delphi Energy & Engine Management Systems
	Current drain -29 (-20) °C (°F)	325 Amps
	Power rating kw (hp)	1.5 (2.0)
Motor drive	Engagement type	Solenoid Actuated, Positive Engagement
	Pinion engages from (front, rear)	Front

Electrical - Ignition System

Type	Electronic (std., opt., n.a.)	Standard	
	Other (specify)	None	
Coil	Manufacturer	Delphi Energy & Engine Management Systems	
	Model	Direct Ignition	
	Current	Engine stopped - A	Less than 100 ma
		Engine idling - A	Less than 1.5 A (Avg.)
Spark plug	Manufacturer	Delphi Energy & Engine Management Systems	
	Model	41 - 940	
	Thread (mm)	14 x 1.25	
	Tightening torque N-m (lb. ft.)	9-20 (7-15)	
	Gap	1.52 mm (0.060 in.)	
Distributor	Number per cylinder	One	
	Manufacturer	Not Applicable	
	Model	Not Applicable	

Electrical - Suppression

Locations & type	
------------------	--



MVMA Specifications

Vehicle Line MONTE CARLO
 Model Year 1997 Issued _____ Revised (●) _____

METRIC (U.S. Customary)

Engine Code/Description

3.4 LITER V6 (207 CID)
 SEQUENTIAL FUEL INJECTION RPO LQ1

Electrical - Supply System

Battery	Manufacturer	Delphi Energy & Engine Management Systems
	Model, std., (opt.)	Standard
	Voltage	12
	Amps at 0° F. cold crank	690 CCA
	Minutes-reserve capacity	90
	Amps/hrs. -20 hr. rate	54
	Location	Engine Compartment
Alternator	Manufacturer	Delphi Energy & Engine Management Systems
	Rating (idle/max. rpm)	42/105 Amps
	Ratio (alt. crank/rev.)	2.74
	Output at idle (rpm, park)	66 Amps W/AC
	Optional (type & rating)	Not Applicable
Regulator	Type	Integral with Alternator

Electrical - Starting System

Motor	Manufacturer	Delphi Energy & Engine Management Systems
	Current drain -29 (-20) °C (°F)	450 Amps
	Power rating kw (hp)	1.7 (2.3)
Motor drive	Engagement type	Solenoid Operated Shift Lever
	Pinion engages from (front, rear)	Front

Electrical - Ignition System

Type	Electronic (std., opt., n.a.)	Electronic Direct Ignition (Standard) - Control Module with Three Integral Coils and One Remote Timing Sensor
	Other (specify)	-
Coil	Manufacturer	Delphi Energy & Engine Management Systems
	Model	1103792
	Current	Engine stopped - A Less than 100 ma Engine idling - A Less than 1.5 A (Avg.)
Spark plug	Manufacturer	Delphi
	Model	41 - 919
	Thread (mm)	14 x 1.25
	Tightening torque N-m (lb. ft.)	10-20 (7.38-14.75)
	Gap	1.14 mm (0.045 in.)
	Number per cylinder	One
Distributor	Manufacturer	Not Applicable
	Model	Not Applicable

Electrical - Suppression

Locations & type	Alternator - Internal Capacitor Suppression Ignition - Internal Resistor/Capacitor Networks
------------------	--



1

2

3

4

5



MVMA Specifications

Vehicle Line MONTE CARLO
 Model Year 1997 Issued _____ Revised (●) _____

METRIC (U.S. Customary)

Model Code/Description

COUPE

Body

Structure	Unitized Body - Frame. Body Side Assembly Includes Full Drawn Quarter Panels. Fully Stamped Inner/Outer Door Panels with Header Extending into Roof. Full-Length Deck Lid Inner/Outer Panels, Full-Drawn Floor Pan.
Bumper system front - rear	Body Color Soft Fascia, Foam Absorber and Rigid Reinforcing Bar Used at Both Front and Rear.
Anti-corrosion treatment	Double-Sided Galvanizing or Gavaneal of all Major Body/Sheet Metal Inner/Outer Panels Including Hood, Deck Lid, Doors as well as Rear and End Panel, Plenum, Fenders, Compartment Pan, Quarter Panels, Rocker Panels and Wheelhouse Outer Panels.

Body - Miscellaneous Information

Type of finish (lacquer, enamel, other)		Base Coat-Clear Coat Acrylic Enamel Over ELPO Primer
Hood	Material & mass	Steel, 17.3 kg.
	Hinge location (front, rear)	Rear
	Type (counterbalance, prop)	Gas Charged Strut
	Release control (internal, external)	Internal
Trunk lid	Material & mass	Steel
	Type (counterbalance, other)	Dual Torque Rods
	Internal release control (elec., mech., n.a.)	Electric, Optional
Hatchback lid	Material & mass	Not Available
	Type (counterbalance, other)	Not Available
	Internal release control (elec., mech., n.a.)	Not Available
Tailgate	Material & mass	Not Available
	Type (drop, lift, door)	Not Available
	Internal release control (elec., mech., n.a.)	Not Available
Vent window control (crank, friction, pivot, power)	Front	Not Applicable
	Rear	Not Applicable
Window regulator type (cable, tape, flex drive, etc.)	Front	Cross Arm Regulator
	Rear	Cross Arm Regulator
Seat cushion type (e.g., 60/40 bucket, bench, wire, foam, etc.)	Front	Custom Cloth - 60/40 Split Bench or 40/40 Bucket, Trim Material Bonded to Foam Leather - 40/40 Bucket on Foam
	Rear	Custom Cloth - Bench, Trim Material Bonded to Foam with Encapsulated Frame Leather - Bench, On Foam with Encapsulated Frame
	3rd seat	Not Applicable
Seat back type (e.g., 60/40 bucket, bench, wire, foam, etc.)	Front	Custom Cloth - 60/40 Split Bench or 40/40 Bucket, Trim Material Bonded to Foam Leather - 40/40 Bucket on Foam
	Rear	Custom Cloth - Bench, Trim Material Bonded to Foam with Encapsulated Frame Leather - Bench, On Foam with Encapsulated Frame
	3rd seat	Not Applicable

Frame

Type and description (separate frame, unitized frame, partially-unitized frame)	Unitized Body/Frame. Bolted-On Powertrain Cradle with Mounting Provisions for Suspension and Engine Mounts.
---	---



7

8

9



MVMA Specifications

Vehicle Line MONTE CARLO
 Model Year 1997 Issued _____ Revised (●) _____

METRIC (U.S. Customary)

Model Code/Description

COUPE

Restraint System

Seating Position			Left	Center	Right
Active	Type & description (lap & shoulder belt, lap belt, etc.)	First seat	3Pt. Single Loop W/Shldr. Retractor, End Release Buckle, Head Rest Guide/All Retractors are Web & Vehicle Sensitive Retractors	Lap Belt Manual Adjustment End Release Buckle	3 Pt. Single Loop W/Shldr. Retractor, End Release Buckle, Head Rest Guide, Child Cinch Retractor/All Retractors are Web & Vehicle Sensitive Retractors
	(lap & shoulder belt, lap belt, etc.)	Second seat	Three Pt. Single Loop W/Shldr. Retractor, End Release Buckle, Child Cinch Retractor, Child Comfort Guide/All Retractors are Web & Vehicle Sensitive Retractors	Lap Belt Manual Adjustment End Release Buckle	Three Pt. Single Loop W/Shldr. Rtrctr., End Release Buckle, Child Cinch Retractor, Child Comfort Guide/All Retractors are Web & Vehicle Sensitive Retractors
	Standard / Optional	Third seat			
Passive	Type & description (air bag, motorized-2-point belt, fixed belt, knee bolster, manual-lap belt)	First seat	Air Bag	Air Bag (Passenger Side)	Air Bag
	Standard / Optional	Second seat			
		Third seat			
Glass		SAE Ref.No.			
Windshield glass exposed surface area cm ² (in. ²)		S1			
Side glass exposed surface area cm ² (in. ²) - total 2 sides		S2	3815.14 cm ²		
Backlight glass exposed surface area cm ² (in. ²)		S3			
Total glass exposed surface area cm ² (in. ²)		S4	--		
Windshield glass (type/thickness)					
Side glass (type/thickness)			5.0 mm		
Backlight glass (type/thickness)					
Tinted (yes/no, location)					
Solar control (yes/no, coated/batched, location)					

Headlamps

Description (sealed beam, halogen, replaceable bulb, etc.)	Halogen, Replacement Bulb Unit
Shape	Aero
Lo-beam type (2A1, 2B1, 2C1, etc.)	Trade No. 9006/HB4
Quantity	Two
Hi-beam type (1A1, 2A1, 1C1, 2C1, etc.)	Trade No. 9005/HB3
Quantity	Two



2

3

4

5

6

7

8

9

10

11

12

13

14

15

16

17

18

19

20

21

22

23

24

25

26

27

28

29

30

31

32

33

34

35



MVMA Specifications

Vehicle Line MONTE CARLO
 Model Year 1997 Issued _____ Revised (●) _____

METRIC (U.S. Customary)

Engine Code/Description

ALL

Climate Control System

Air conditioning (std., opt., man., auto.)		Standard - L82
Condenser	Type	Tube & Fin
	Eff. face area (sq. mm.)	315,181
	Fins per inch	13
Evaporator	Type	U Flow, Aluminum
	Eff. face area (sq. mm.)	48,437
	Fins per inch	14
Heater core	Material	Aluminum
	Eff. face area (sq. mm.)	33,028
	Fins per inch	30
Compressor	Type	V5
	Displacement (cc.)	Variable Displacement
	Manufacturer	Delphi Harrison Thermal Systems
	A/C pulley ratio	1.37
Accumulator	Type	Non-Serviceable, Sealed, Integral Design
	Height (mm.)	206
	Diameter (mm.)	89
Receiver	Type	Not Applicable
	Height (mm.)	Not Applicable
	Diameter (mm.)	Not Applicable
Refrigerant control (COT, TVS, etc.)		Variable Displacement Compressor VDOT
Heater water valve (yes / no)		No
Refrigerant (R - 12, R - 134a, etc.)		R134A
Charge level (lbs. - oz.)		2.0 lbs.
Cold engine lockout switch (yes / no)		No
Wide open throttle cutout switch (yes / no)		Yes
Power steering cutout switch (yes/no)		Yes, LQ1 Only



4

4

4

4

4

4



MVMA Specifications

Vehicle Line MONTE CARLO
 Model Year 1997 Issued _____ Revised (●) _____

METRIC (U.S. Customary)

Model Code/Description

COUPE

Convenience Equipment (standard, optional, n.a.)

	Clock (digital, analog)	Digital - In Radio, Standard
	Compass / thermometer	Not Available
	Console (floor, overhead)	Optional, Floor (Overhead - Not Available)
	Defroster, electric windshield	Not Available
	Defroster, electric backlight	Optional
Electronic	Diagnostic monitor (integrated, individual)	Not Available
	Instrument cluster (list instruments)	Not Available
	Keyless entry	Optional
	Tripminder (avg. spd., fuel)	Not Available
	Voice alert (list items)	Not Available
	Other	
	Fuel door lock (remote, key, electric)	
Integrated Child Seating	Std./opt. & location in vehicle	Not Available
	Number of occupants	Not Available
	Occupant weight/height (min. & max.)	Not Available
	Restraint system description (3 or 5-point belts/booster seat capability)	Not Available
Lamps	Auto head on/off delay, dimming	Not Available
	Cornering	Not Available
	Courtesy (map, reading) Dome	Standard
	Door lock, ignition	
	Engine compartment	Standard
	Fog	Not Available
	Glove compartment	Standard
	Trunk	Standard
	Illuminated entry system (list lamps, activation)	Sustained Interior Illumination
	Other Ashtray	Standard
CHMSL	Standard	
Mirrors	Day / night (auto., man.)	Standard - Manual
	L.H. (remote, power, heated)	Standard - Remote, Optional - Power
	R.H. (convex, remote, power, heated)	Standard - Manual, Optional - Power
	Visor vanity (RH / LH, illuminated)	Not Available, (Uncovered Visor Vanity - Optional)
	Navigation system (describe)	Not Available
	Parking brake-auto release (warning light)	Standard - Warning Light



7

8



MVMA Specifications

Vehicle Line MONTE CARLO
 Model Year 1997 Issued _____ Revised (●) _____

METRIC (U.S. Customary)

Model Code/Description

COUPE

Convenience Equipment (standard, optional, n.a.)

Power equipment	Deck lid (release, pull down)		Optional, Electric Release	
	Door locks (manual, automatic, describe system)		Electric, Standard	
	Seats	2 - 4 - 6 way, etc.		Standard Four Way, Driver Side Only; Optional Six-Way
		Reclining (R.H., L.H.)		Standard - Manual
		Memory (R.H., L.H., preset recline)		Not Available
		Support (lumbar, hip, thigh, etc.)		Not Available
		Heated (R.H., L.H., other)		Not Available
	Side windows		Standard Power	
	Vent windows		Not Applicable	
Rear windows		Not Applicable		
Radio systems	Antenna (location, whip, w/shield, power)		Standard, Fixed Whip Located on Right Rear Upper Quarter Panel	
	Standard	AM, FM, stereo, tape, compact disc, graphic equalizer, theft deterrent, radio prep package, headphone jacks, etc.	AM/FM Stereo, Seek & Scan/Standard	
	Optional		AM/FM Stereo, Seek & Scan, Cassette ATC (Theft Deterrent) - Optional AM/FM Stereo, Seek & Scan, Cassette - Optional AM/FM Stereo, Seek & Scan/Compact Disc ATC (Theft Deterrent) - Optional	
	Speaker (number, location)		Standard - Two In Front Doors, Two In Package Shelf, Optional - Dual Coax	
Roof: open air or fixed (flip-up, sliding, "T")			Not Available	
Speed control device			Optional, Automatic Electronic	
Speed warning device (light, buzzer, etc.)			Not Available	
Tachometer (rpm)			Optional (Included as Part of Optional Gauge Package)	
Telephone system (describe)			Not Available	
Theft deterrent system			Not Available	

Trailer Towing

Towing capable	Yes / No	Yes
Engine / transmission / axle	Std. / Opt.	3.1L, Four-Spd. Auto., 3.33; 3.4L, Four-Spd. Auto., 3.43
Tow class (I, II, III)*	Std. / Opt.	One
Max. gross trailer wgt. (lbs.)	Std. / Opt.	1000
Max. trailer tongue load (lbs.)	Std. / Opt.	100
Towing package available	Yes / No	No

* Class I - 2,000 lbs. Class II - 3,500 lbs. Class III - 5,000 lbs.



-

4



MVMA Specifications

Vehicle Line MONTE CARLO
 Model Year 1997 Issued _____ Revised (●) _____

METRIC (U.S. Customary)

Vehicle Dimensions See Key Sheets for definitions

All dimensions to ground are for comparative purposes only. Dimensions are to be shown for all base body models of each vehicle line. SAE Ref. no. refers to the definition published in SAE Recommended Practice J1100 "Motor Vehicle Dimensions," unless otherwise specified.

Model Code/Description

SAE
Ref.
No.

COUPE

Width

Tread (front)	W101	1512 (59.5)
Tread (rear)	W102	1500 (59.0)
Vehicle width	W103	1842 (72.5)
Body width at SgRP (front)	W117	1795 (70.6)
Vehicle width (front doors open)	W120	4057 (159.7)
Vehicle width (rear doors open)	W121	Not Applicable
Tumble-home (degrees)	W122	28
Outside mirror width	W410	1980 (77.9)

Length

Wheelbase	L101	2730 (107.5)
Vehicle length	L103	5099 (200.7)
Overhang (front)	L104	1172 (46.1)
Overhang (rear)	L105	1197 (47.1)
Upper structure length	L123	2877 (113.2)
Rear Wheel C/L "X" coordinate	L127	4525 (178.1)

Height **

Passenger distribution (front/rear)	PD1 .2,3	**
Trunk/cargo load		**
Vehicle height	H101	1368 (53.8)
Cowl point to ground	H114	
Deck point to ground	H138	
Rocker panel-front to ground	H112	194 (7.6)
Rocker panel-rear to ground	H111	195 (7.7)
Windshield slope angle (degrees)	H122	63 (2.4)
Backlight slope angle (degrees)	H121	69 (2.7)

Ground Clearance **

Front bumper to ground	H102	
Rear bumper to ground	H104	
Bumper to ground front at curb mass (wt.)	H103	
Bumper to ground rear at curb mass (wt.)	H105	
Angle of approach (degrees)	H106	
Angle of departure (degrees)	H107	
Ramp breakover angle (degrees)	H147	
Axle differential to ground (front/rear)	H153	
Min. running ground clearance	H156	165 (6.5)
Location of min. running ground clear.		

** All Vehicle Height And Ground Clearance Are Made Using EPA Loaded Vehicle Weight, Loading Conditions. EPA loaded vehicle weight is the base vehicle weight plus all coolant and fluids necessary for operation plus 100% of the fuel capacity, plus the weight of all options and accessories which weigh three pounds or more and which are sold on at least 33% of the car line, plus two occupants.

All linear dimensions are in millimeters (inches).



1
2



MVMA Specifications

Vehicle Line MONTE CARLO
 Model Year 1997 Issued _____ Revised (●) _____

METRIC (U.S. Customary)

Vehicle Dimensions

See Key Sheets for definitions

Model Code/Description

SAE
Ref.
No.

COUPE

Front Compartment

SgRP front, "X" coordinate	L31	3140 (123.6)
Effective head room	H61	963 (37.9)
Max. effective leg room (accelerator)	L34	1076 (42.4)
SgRP to heel point	H30	240 (9.4)
SgRP to heel point	L53	876 (34.4)
Back angle (degrees)	L40	26.0 (1.0)
Hip angle (degrees)	L42	98.0 (3.9)
Knee angle (degrees)	L44	128 (5.0)
Foot angle (degrees)	L46	87 (3.4)
Design H-point front travel	L17	208 (8.1)
Normal driving & riding seat track trvl.	L23	179 (7.0)
Shoulder room	W3	1460 (57.5)
Hip room	W5	1356 (53.4)
*** Upper body opening to ground	H50	1203 (47.3)
Steering wheel maximum diameter*	W9	375 (14.7)
Steering wheel angle (degrees)	H18	22 (0.9)
Accel. heel pt. to steer. whl. cntr.	L11	
Accel. heel pt. to steer. whl. cntr.	H17	
Undepressed floor covering thickness	H67	25 (1.0)

Front Compartment Interior Dimensions are Measured with the Seating Reference Point (SgRP) _____ mm forward and _____ mm Upward of Rearmost Position.

Rear Compartment

SgRP point couple distance	L50	792 (31.1)
Effective head room	H63	938 (36.9)
Min. effective leg room	L51	886 (34.9)
SgRP (second to heel)	H31	250 (9.8)
Knee clearance	L48	22 (0.8)
Shoulder room	W4	1463 (57.6)
Hip room	W6	1310 (51.6)
*** Upper body opening to ground	H51	
Back angle (degrees)	L41	28
Hip angle (degrees)	L43	84
Knee angle (degrees)	L45	87
Foot angle (degrees)	L47	123
Depressed floor covering thickness	H73	17 (6.7)

Luggage Compartment

Usable luggage capacity L (cu. ft.)	V1	445 (17.5)
*** Lifter height	H195	679 (26.7)

Interior Volumes (EPA Classification)

Vehicle class	Mid-Size
Interior volume index including trunk/cargo (cu. ft.)**	111.6
Trunk/cargo index (cu. ft.)	15.5

* See page 14.

** See definition page 33.

All linear dimensions are in millimeters (inches) unless otherwise noted.

*** EPA Loaded Vehicle Weight, Loading Conditions



e

r

.

.



MVMA Specifications

Vehicle Line MONTE CARLO
 Model Year 1997 Issued _____ Revised (●) _____

METRIC (U.S. Customary)

Vehicle Dimensions See Key Sheets for definitions

Model Code/Description

COUPE

Station Wagon/MPV*
 -Third Seat

SAE
 Ref.
 No.

(NOT APPLICABLE)

Seat facing direction	SD1	
SgRP couple distance	L85	
Shoulder room	W85	
Hip room	W86	
Effective leg room	L86	
Effective head room	H86	
SgRP to heel point	H87	
Knee clearance	L87	
Back angle (degrees)	L88	
Hip angle (degrees)	L89	
Knee angle (degrees)	L90	
Foot angle (degrees)	L91	

Station Wagon/MPV* - Cargo Space

(NOT APPLICABLE)

Cargo length (open front)	L200	
Cargo length (open second)	L201	
Cargo length (closed front)	L202	
Cargo length (closed second)	L203	
Cargo length at belt (front)	L204	
Cargo length at belt (second)	L205	
Cargo width (wheelhouse)	W201	
Rear opening width at floor	W203	
Opening width at belt	W204	
Min. rear opening width above belt	W205	
Cargo height	H201	
Rear opening height	H202	
Tailgate to ground height	H250	
Front seat back to load floor height	H197	
Cargo volume index m ³ (ft. ³)	V2	
Hidden cargo volume index m ³ (ft. ³)	V4	
Cargo volume index-rear of 2-seat	V10	
Cargo volume index*	V6	
Cargo width at floor*	W500	
Maximum cargo height*	H505	

Hatchback - Cargo Space

(NOT APPLICABLE)

Cargo length at front seatback height	L208	
Cargo length at floor (front)	L209	
Cargo length at second seatback height	L210	
Cargo length at floor (second)	L211	
Front seatback to load floor height	H197	
Second seatback to load floor height	H198	
Cargo volume index m ³ (ft. ³)	V3	
Hidden cargo volume index m ³ (ft. ³)	V4	
Cargo volume index - rear of 2-seat	V11	

All linear dimensions are in millimeters (inches) unless otherwise noted.

* MPV - Multipurpose Vehicle

** EPA Loaded Vehicle Weight, Loading Conditions

-

.

MVMA Specifications

Vehicle Line MONTE CARLO
 Model Year 1997 Issued _____ Revised (●) _____

METRIC (U.S. Customary)

Model Code/
Description

COUPE

Vehicle Fiducial Marks

Fiducial Mark Number*	Define Coordinate Location	
Front	X	Fiducial Mark to Vertical Zero Grid Line - Front Measured Horizontally, from the Zero Grid Line to the Front Fiducial Mark Located on Top of the Front Seat Adjuster Mounting Bolt.
	Y	Fiducial Mark to Centerline of Car - Front, Width Measurement made from Centerline Car to Fiducial Mark Located on Top of the Front Seat Adjuster Mounting Bolt.
	Z	Fiducial Mark to Horizontal zero Grid Line - Front, Measured Vertically from Zero Grid Line to Front Fiducial Mark Located on Top of the Front Seat Adjuster Mounting Bolt.
Rear	X	Fiducial Mark to Vertical Zero Grid Line - Rear, Measured Horizontally from the Zero Grid Line to Rear Fiducial Mark Located on the Rail (Compartment Pan - Longitudinal.)
	Y	Fiducial Mark to Centerline of Car - Rear, Width Measurement made from Centerline of Car to Fiducial Mark Located on the Rail (Compartment Pan - Longitudinal.)
	Z	Fiducial Mark to Horizontal Zero Grid Line - Rear, Measured Vertically from the Zero Grid Line to Rear Fiducial Mark Located on the Rail (Compartment Pan - Longitudinal.)
NOTE: Provide 3 of 4 Fiducial Mark Locations		
Front	W21**	555.0
	L54**	2775.0 (109.2)
	H81**	278.0 (10.9)
	H161**	334.0 (13.1)
	H163**	314.0 (12.3)
Rear	W22**	488 (19.2)
	L55**	5200 (204.7)
	H82**	388 (15.2)
	H162**	445 (17.5)
	H164**	425 (16.7)

* Reference - SAE Recommended Practice, J182a, Motor Vehicle Fiducial Marks.

** Reference - SAE Recommended Practice J1100 - Motor Vehicle Dimensions.

*** EPA Loaded Vehicle Weight, Loading Conditions

All linear dimensions are in millimeters (inches) unless otherwise noted.



2

4

7

1

1





5

3

1

1

1

1

1



MVMA Specifications
METRIC (U.S. Customary)

Vehicle Line MONTE CARLO
 Model Year 1997 Issued _____ Revised (●) _____

Code	Equipment	Optional Equipment Differential Mass (weight)*			Remarks Restrictions, Requirements
		MASS. kg. (lb.)			
		Front	Rear	Total	
AG1	Seat Adj-6 Way Pwr Drv Only	0.6 (1.3)	0.6 (1.3)	1.2 (2.6)	
AM9	Seat-RR, Split Back, Fldg.	0.4 (0.9)	4.0 (4.4)	2.4 (5.3)	
AQ9	Seat Front-Bucket/Recliner	6.0 (13.2)	6.0 (13.2)	12.0 (26.4)	
AR9	Seat Front Bkt, Euro P/D Recliner	-2.4 (-5.3)	-1.8 (-4.0)	-4.2 (-9.3)	
A90	Lock-RR Compt Lid, Rem Cont Ele.	0.0 (0.0)	0.2 (0.44)	0.2 (0.44)	
BF9	Cover-Flr. Mat Delete	-1.8 (4.0)	-1.4 (3.0)	-3.2 (7.0)	
C49	Defogger-RR Window, Electric	0.0 (0.0)	0.2 (0.4)	0.2 (0.4)	
DG7	Mirror - O/S, L&R, Elec. Painted	0.2 (0.4)	0.0 (0.0)	0.2 (0.4)	
D55	Console-Frt. Compt. Floor	2.0 (4.4)	2.0 (4.4)	4.0 (8.8)	
F41	Suspension System Frt/RR, Firm Ride Hdlg.	1.0 (2.2)	1.0 (2.2)	2.0 (4.4)	
KC4	Cooling System - Eng. Oil	2.4 (5.3)	-0.2 (-0.4)	2.2 (4.9)	
KD1	Cooling System - Trans Oil	1.4 (3.1)	-0.2 (-0.4)	1.2 (2.6)	
K05	Heater - Engine Block	0.4 (0.9)	0.0 (0.0)	0.4 (0.9)	
K34	Cruise Control Auto Electronic	1.2 (2.6)	0.0 (0.0)	1.2 (2.6)	
LQ1	Engine-Gas, 6 Cylinder 3.4L, MF1	61.4 (135.4)	-7.8 (-17.2)	53.6 (118.2)	
NC5	Exhaust-Dual Vert Tail Pipes	1.0 (2.2)	10.8 (23.8)	11.8 (26.0)	

* Also see Engine - General Section for dressed engine mass (weight.)



1

2



MVMA Specifications
METRIC (U.S. Customary)

Vehicle Line MONTE CARLO
 Model Year 1997 Issued _____ Revised (●) _____

		Optional Equipment Differential Mass (weight)*			
Code	Equipment	MASS, kg. (lb.)			Remarks Restrictions, Requirements
		Front	Rear	Total	
N81	Full Size Spare Tire	0.0 (0.0)	2.6 (5.7)	2.6 (5.7)	
PY0	Wheel - 16 x 6.5 Aluminum	-3.2 (-7.1)	-3.2 (-7.1)	-6.4 (-14.2)	
QNX	Tire-P225/60R16/NBL	0.6 (1.3)	0.6 (1.3)	1.2 (2.6)	
QVG	Tire-P225/60R16/N	2.2 (4.9)	2.2 (4.9)	4.4 (9.8)	
UA1	Battery-High Capacity, Wet	1.6 (3.5)	0.0 (0.0)	1.6 (3.5)	
UL0	Radio-AM/FM Stereo	0.6 (1.3)	0.2 (0.4)	0.8 (1.7)	
UL5	Radio-Delete	-2.2 (-4.9)	-1.4 (-3.1)	-3.6 (-8)	
UM6	Radio-AM/FM Stereo, S&S, Cass, CL	0.6 (1.3)	0.2 (0.4)	0.8 (1.7)	
UN0	Radio-AM/FM Cassette	.8 (1.8)	.2 (.4)	1.0 (2.2)	
UV8	Telephone Provision	0.2 (0.4)	0.2 (0.4)	0.4 (0.8)	
U62	Speaker System - 4, Dual Frt Coax	0.2 (0.4)	0.2 (0.4)	0.4 (0.8)	
VB7	Bumper Frt & RR Sport	-0.6 (-1.3)	0.2 (0.4)	-0.4 (-0.9)	
VK3	License Plt Frt Mount Package	0.4 (0.8)	-0.2 (-0.4)	0.2 (0.4)	
VR6	Hook Tie Down	0.2 (0.4)	0.2 (0.4)	0.4 (0.8)	
V08	Radiator-Heavy Duty	2.0 (4.4)	0.0 (0.0)	2.0 (4.4)	
Z7G	Monte Carlo Z34	0.4 (0.9)	0.2 (0.4)	0.6 (1.3)	

* Also see Engine - General Section for dressed engine mass (weight.)



2

3

4



Specifications METRIC

Exterior Vehicle And Body Dimensions - Key Sheet

Exterior Width Dimensions

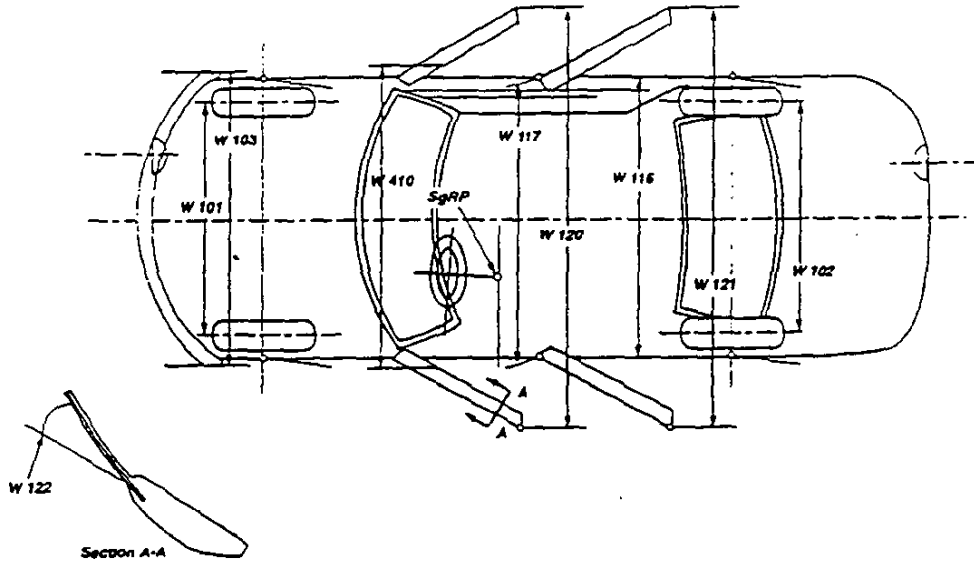

Exterior Length & Height Dimensions

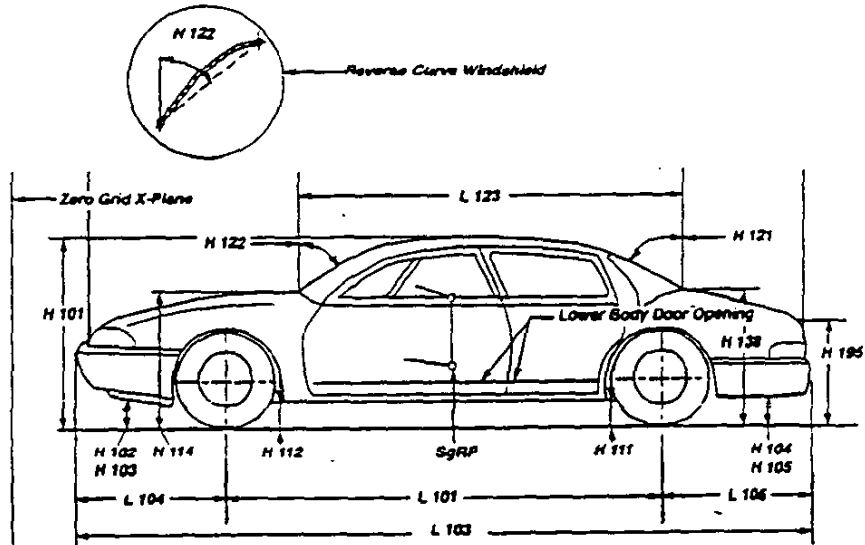

Ground Clearance Dimensions

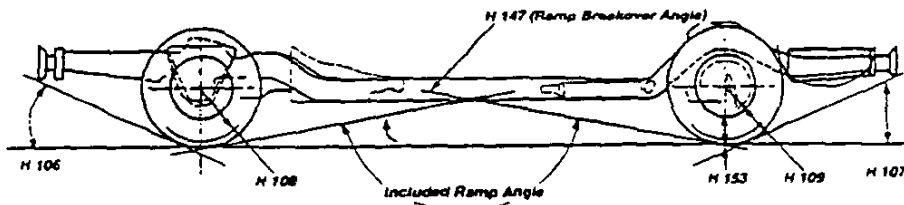



8

7



Specifications METRIC

Interior Vehicle And Body Dimensions - Key Sheet

Interior Length Dimensions

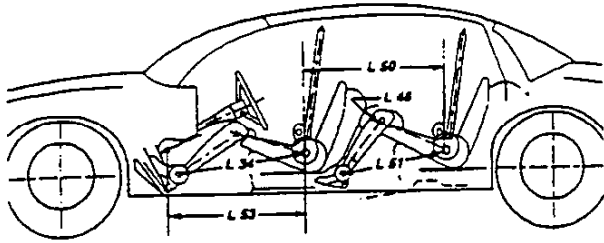

Interior Height Dimensions

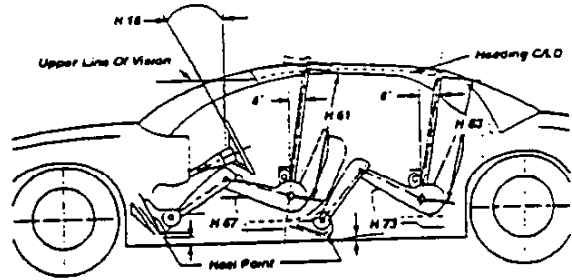

Interior Height Dimensions

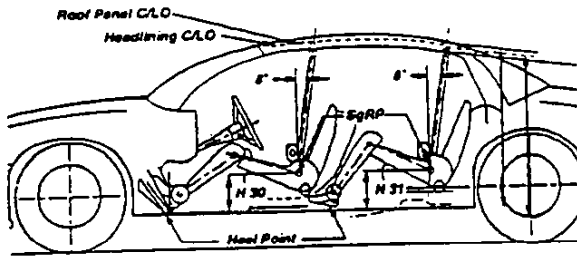

Interior Length Dimensions

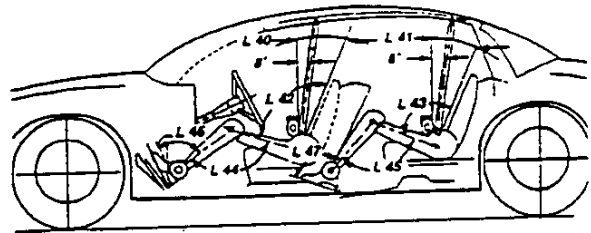

Interior Width Dimensions

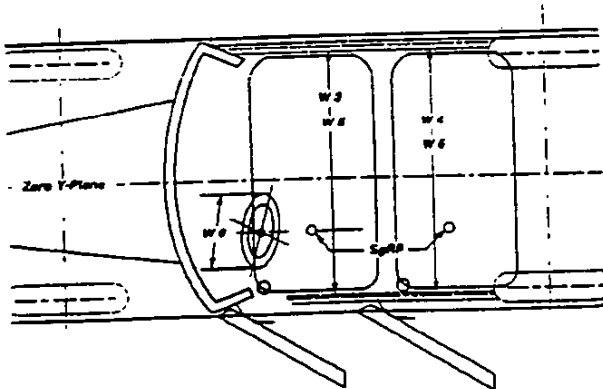

Interior Height Dimensions

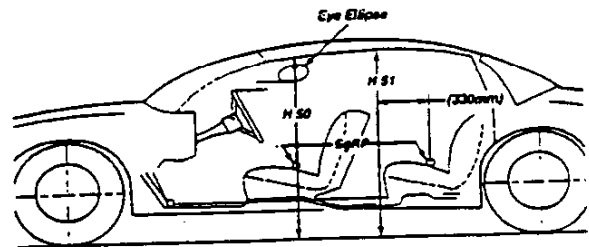

Specifications METRIC

Interior Vehicle And Body Dimensions - Key Sheet

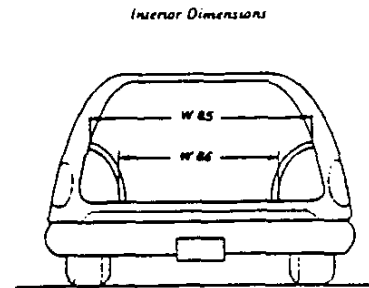
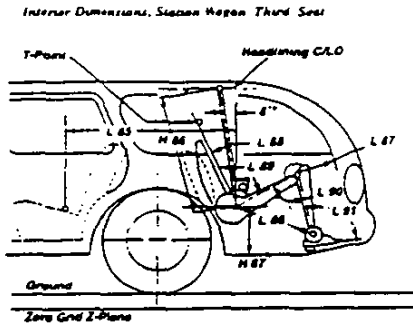

Cargo Space Dimensions

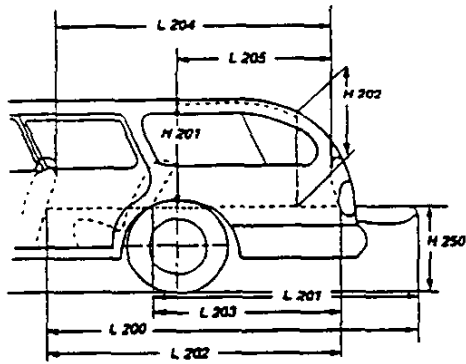

Cargo Space Dimensions

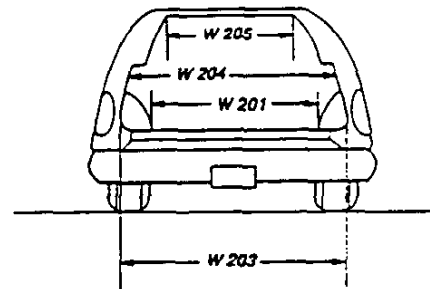

Cargo Space Dimensions

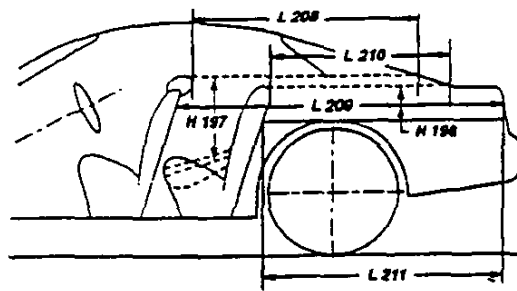

Multipurpose Vehicle Cargo Space

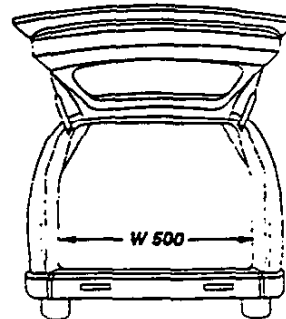
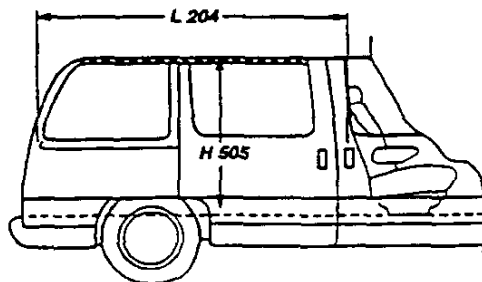

Specifications

METRIC

Exterior Vehicle And Body Dimensions - Key Sheet

Dimensions Definitions

Seating Reference Point

SEATING REFERENCE POINT means the manufacturer's design reference point which -
 (a) Establishes the rearmost normal design driving or riding position of each designated seating position in a vehicle;
 (b) Has coordinates established relative to the design vehicle structure;
 (c) Simulates the position of the pivot center of the human torso and thigh; and
 (d) is the reference point employed to position the two dimensional templates described in SAE Recommended Practice J826, "Devices for Use in Defining and Measuring Vehicle Seating Accommodations."

Width Dimensions

- W101 TREAD-FRONT. The dimension measured between the tire centerlines at the ground.
- W102 TREAD-REAR. The dimension measured between the tire centerlines at the ground. In case of dual wheels, the dimension will be measured to the centerline of tire and wheel assemblies.
- W103 VEHICLE WIDTH. The maximum dimension measured between the widest point on the vehicle, excluding exterior mirrors, flexible mud flaps, marker lamps, but including bumpers, moldings, sheet metal protrusions or dual wheels, if standard equipment.
- W117 BODY WIDTH AT SgRP-FRONT. The dimension measured laterally between the widest points on the body at the SGRP-front, excluding door handles, applied moldings, or appliques.
- W120 VEHICLE WIDTH-FRONT DOORS OPEN. The dimension measured between the widest point on the rear doors in maximum hold-open position.
- W121 VEHICLE WIDTH-REAR DOORS OPEN. The dimension measured between the widest point on the rear doors in maximum hold-open position. For vehicles with a rear door on only one side, this dimension is to the zero "Y" plane.
- W122 TUMBLE-HOME. STRAIGHT SIDE GLASS. The angle measured from a vertical to the outside surface of the front door glass at the SgRP "X" plane.
 CURVED SIDE GLASS. The angle measured from a vertical to a chord extending from the upper DLO to the lower DLO at the outside surface of the front door glass at the front SgRP "X" plane.
- W410 OUTSIDE MIRROR WIDTH: The dimension between the widest point on the outside mirrors. The standard right and left mirror adjusted for normal driving will be shown unless otherwise noted. When only one outside mirror is standard, the dimension will be to the zero "Y" plane.

Length Dimensions

- L101 WHEELBASE (WB). The dimension measured longitudinally between front and rear wheel centerline. In case of dual rear axles, the dimension shall be to the midpoint of the centerlines of the rear wheels.
- L103 VEHICLE LENGTH. The maximum dimension measured longitudinally between the foremost point and the rearmost point on the vehicle, including bumper, bumper guards, tow hooks and/or rub strips, if standard equipment.
- L104 OVERHANG-FRONT. The dimension measured longitudinally from the centerline of the front wheels to the foremost point on the vehicle including bumper, bumper guards, tow hook and/or rub strips, if standard equipment.
- L105 OVERHANG-REAR. The dimension measured longitudinally from the centerline of the rear wheels; or in the case of dual rear axles, the dimension shall be the midpoint of the centerlines of the rear wheels, to the rearmost point on the vehicle including rear bumpers, bumper guards, tow hooks and rub strips, if standard equipment.

- L123 UPPER STRUCTURE LENGTH. The dimension measured longitudinally from the cowli point to the deck point.
- L127 REAR WHEEL CENTERLINE "x" COORDINATE or in the case of dual rear axles, the coordinate shall be the midpoint of the distance between the rear axle centerlines.

Height Dimensions

- H101 VEHICLE HEIGHT. The dimension measured vertically from the highest point on the vehicle body to ground.
- H111 ROCKER PANEL-REAR TO GROUND. The dimension measured vertically from the bottom of the rocker or side quarter panel at the front of the rear wheel opening, excluding flanges, to ground.
- H112 ROCKER PANEL-FRONT TO GROUND. The dimension measured vertically from the foremost point on the bottom of the rocker panels, excluding flanges, to ground.
- H114 COWL POINT TO GROUND. Measured at zero "Y" plane.
- H121 BACKLIGHT SLOPE ANGLE. The angle between the vertical reference line and the surface of backlight at vehicle zero "Y" plane. For curve backlight, the angle is to chord of backlight arc from lower DLO to upper DLO.
- H122 WINDSHIELD SLOPE ANGLE. The angle between the vertical reference line and a chord of the windshield arc running from the lower DLO to the upper DLO at the vehicle zero "Y" plane. In the case of wrap over glass, the angle to be measured will be formed by a chord 457 mm (18.0 in.) long drawn from the lower DLO to the intersecting point on the windshield.
- H138 DECK POINT TO GROUND. Measured at zero "Y" plane.
- H109 STATICLOAD-TIRE RADIUS-REAR. Specified by the manufacturer in accordance with composite TIRE SECTION STANDARD.

Ground Clearance Dimensions

- H102 FRONT BUMPER TO GROUND. The minimum dimension measured vertically from the lowest point on the front bumper to ground, including bumper guards, if standard equipment.
- H103 FRONT BUMPER TO GROUND-CURB MASS(WT.). Measured in the same manner as H102.
- H104 REAR BUMPER TO GROUND. The minimum dimension measured vertically from the lowest point on the rear bumper to ground, including bumper guards, if standard equipment.
- H105 REAR BUMPER TO GROUND-CURB MASS(WT.). Measured in the same manner as H104.
- H106 ANGLE OF APPROACH. The angle measured between a line tangent to the front tire static loaded radius arc and the initial point of structural interference forward of the front tire to ground. The limiting structural component shall be designated.
- H107 ANGLE OF DEPARTURE. The angle measured between a line tangent to the rear tire static loaded radius arc and the initial point of structural interference rearward of the rear tire to ground. The limiting component shall be designated.
- H147 RAMP BREAKOVER ANGLE. The angle measured between two lines tangent to the front and rear tire static loaded radius and intersecting at a point on the underside of the vehicle which defines the largest ramp over which the vehicle can roll.
- H153 REAR AXLE DIFFERENTIAL TO GROUND. The minimum dimension measured from the rear axle differential to ground.
- H156 MINIMUM RUNNING GROUND CLEARANCE. The minimum dimension measured from the sprung vehicle to ground. Specify location.



1
2
3

4

5

6

7

8



Specifications

METRIC

Interior Vehicle And Body Dimensions - Key Sheet

Dimensions Definitions

Glass Areas

- S1 Windshield area.
 S2 Side windows area. Includes the front door, rear door, vents, and rear quarter windows on both sides of the vehicle.
 S3 Backlight areas.
 S4 Total area. Total of all areas (S1 + S2 + S3).

Fiducial Mark Dimensions

- Fiducial Mark - Number 1
 L54 "X" coordinate.
 W21 "Y" coordinate.
 H81 "Z" coordinate.
 H161 Height "Z" coordinate to ground at curb weight.
 H163 Height "Z" coordinate to ground.
 Fiducial Mark - Number 2
 L55 "X" coordinate.
 W22 "Y" coordinate.
 H82 "Z" coordinate.
 H162 Height "Z" coordinate to ground at curb weight.
 H164 Height "Z" coordinate to ground.

Front Compartment Dimensions

- L11 ACCELERATOR WHEEL POINT TO STEERING WHEEL CENTER. The dimension measured horizontally from the AHP to the intersection of the steering column centerline and a plane tangent to the upper surface of the steering wheel rim.
 L17 DESIGN-H-POINT-FRONT TRAVEL. The dimension measured horizontally between the design H-point-front in the foremost and rearmost seat track positions. (See SAE J1100)
 L23 NORMAL DRIVING AND RIDING SEAT TRACK TRAVEL. The dimension measured horizontally between a point on the design H-point travel line from the SgRP to the displaced point on the design H-point travel line with the seat moved to the foremost seat position, but not to include seat track travel used for purposes other than normal driving and riding positions. (See SAE J1100).
 L31 SgRP-Front. "X" Coordinated.
 L34 MAXIMUM EFFECTIVE LEG ROOM-ACCELERATOR. The dimension measured along a line from the ankle pivot center to the SgRP-front plus 254 mm (10.0 in.) measured with right foot on the undepressed accelerator pedal. For vehicles with SgRP to heel (H30) greater than 18 in., the accelerator pedal may be depressed as specified by the manufacturer. If the accelerator is depressed, the manufacturer shall place foot flat on pedal and note the depression of the pedal.
 L40 BACK ANGLE-FRONT. The angle measured between a vertical line through the SgRP-front and the torso line. If the seatback is adjustable, use the normal driving and riding position specified by the manufacturer.
 L42 HIP ANGLE-FRONT. The angle measured between torso line and thigh centerline.
 L44 KNEE ANGLE-FRONT. The angle measured between thigh centerline and lower leg centerline measured on the right leg.
 L46 FOOT ANGLE-FRONT. The angle measured between the lower leg centerline and a line tangent to the ball and heel of the bare foot flesh line measured on the right leg. Ref SAE J826.
 L53 SgRP-FRONT TO HEEL. The dimension measured horizontally from the SgRP-front to the accelerator heel point.
 W3 SHOULDER ROOM-FRONT. The minimum dimension measured laterally between the trimmed surfaces on the "X" plane through the SgRP-front at height between the belt line and 254 mm (10.0 in.) above the SgRP-front, excluding the door assist strap and attaching parts.

- W5 HIP ROOM-FRONT. The minimum dimension measured laterally between the trimmed surfaces on the "X" plane through the SgRP-front within 25 mm (1.0 in.) below and 76 mm (3.0 in.) above the SgRP-front and 76 mm (3.0 in.) fore and aft of the SgRP-front.
 W9 STEERING WHEEL MAXIMUM OUTSIDE DIAMETER. Define if other than round.
 H7 ACCELERATOR HEEL POINT TO THE STEERING WHEEL CENTER. The dimension measured vertically from the AHP-front to the intersection of the steering column centerline to a plane tangent to the upper surface of the steering wheel rim.
 H18 STEERING WHEEL ANGLE. The angle measured from a vertical to the surface plane of the steering wheel.
 H30 SgRP-FRONT TO HEEL. The dimension measured vertically from the SgRP-front to the accelerator heel point.
 H50 UPPER BODY OPENING TO GROUND-FRONT. The dimension measured vertically from the trimmed body opening to the ground on the SgRP-front "X" plane.
 H61 EFFECTIVE HEAD ROOM-FRONT. The dimension measured along a line 8 deg. rear of vertical from the SgRP-front to the headlining plus 102 mm (4.0 in.).
 H67 FLOOR COVERING THICKNESS - UNDEPRESSED - FRONT. The dimension measured vertically from the surface of the undepressed floor covering to the underbody sheet metal at the accelerator heel point.

Rear Compartment Dimensions

- L41 BACK ANGLE-SECOND. The angle measured between a vertical line through the SgRP-second and the torso line.
 L43 HIP ANGLE-SECOND. The angle measured between torso line and thigh centerline.
 L45 KNEE ANGLE-SECOND. The angle measured between thigh centerline and lower leg centerline.
 L47 FOOT ANGLE-SECOND. The angle measured between the lower leg centerline and a line tangent to the ball and heel of the three-dimensional devices bare foot flesh line (Reference J826).
 L48 KNEE CLEARANCE-SECOND. The minimum dimension measured from the knee pivot center to the back of the front seatback minus 51 mm (2.0 in.).
 L50 SgRP COUPLE DISTANCE-SECOND. The dimension measured horizontally from the driver SgRP-front to the SgRP-second.
 L51 MINIMUM EFFECTIVE LEG ROOM-SECOND. The dimension measured along a line from the ankle pivot center to the SgRP-second plus 254 mm (10.0 in.).
 W4 SHOULDER ROOM-SECOND. The minimum dimension measured laterally between door or quarter trimmed surfaces on the "X" plane through the SgRP-second at height between 254-406 mm (10.0-16.0 in.) above the SgRP-second, excluding the door assist straps and attaching parts.
 W6 HIP ROOM-SECOND. Measured in the same manner as W5.
 H31 SgRP-SECOND TO HEEL. The dimension measured vertically from the SgRP-second to the two dimensional device heel point on the depressed floor covering.
 H51 UPPER BODY OPENING TO GROUND-SECOND. The dimension measured vertically from the trimmed body opening to the ground on the "X" plane 330 mm (13.0 in.) forward of the SgRP-second.
 H63 EFFECTIVE HEAD ROOM-SECOND. The dimension measured along a line 8 deg. rear of vertical from the SgRP to the headlining, plus 102 mm (4.0 in.).
 H73 FLOOR COVERING-DEPRESSED-SECOND. The dimension measured vertically from the heel point to the underbody sheet metal.



Specifications

METRIC

Interior Vehicle And Body Dimensions - Key Sheet

Dimensions Definitions

Luggage Compartment Dimensions

V1 USABLE LUGGAGE CAPACITY-Total of volumes of individual pieces of standard luggage set plus H-boxes stowed in the luggage compartment in accordance with the procedure described in paragraph 8.2 of SAE-J1100a.

Interior Volumes (EPA Classification)

The Interior Index is listed for each body style except two seaters. The Interior Volume Index estimates the space in a car. It is based on four measurements - head room, shoulder room, hip room, and leg room - for the front and rear seats, plus trunk capacity.

The Trunk/Cargo Index is an estimate of the size of the trunk/cargo space. In station wagons and hatchbacks it is an estimate of the space behind the second seat.

Station Wagon/MPV - Third Seat Dimensions

L85 SgRP COUPLE DISTANCE-THIRD. The dimension measured horizontally from the SgRP-second to the SgRP-third.

L86 EFFECTIVE LEG ROOM-THIRD. The dimension measured along a line from the ankle pivot center to the SgRP-third plus 254 mm (10.0 in.).

L87 KNEE CLEARANCE-THIRD. The minimum dimension from the knee pivot center to the back of second seatback minus a constant of 51 mm (2.0in.). With rear-facing third seat, dimension is measured to closure.

L88 BACK ANGLE-THIRD. Measured in the same manner as L41.

L89 HIP ANGLE-THIRD. Measured in the same manner as L43.

L90 KNEE ANGLE-THIRD. Measured in the same manner as L45.

L91 FOOT ANGLE-THIRD. Measured in the same manner as L47.

W85 SHOULDER ROOM-THIRD. Measured in the same manner as W4.

W86 HIP ROOM-THIRD. Measured in the same manner as W5.

H86 EFFECTIVE HEAD ROOM-THIRD. The dimension, measured along a line 8 deg. from the SgRP-third to the headlining rear of vertical plus a constant of 102 mm (4.0 in.).

H87 SgRP-THIRD TO HEEL POINT

SD1 SEAT FACING DIRECTION-THIRD.

Station Wagon/MPV - Cargo Space Dimensions

L200 CARGO LENGTH-OPEN-FRONT. The minimum dimension measured longitudinally from the back of the front seatback at the height of the undepressed floor covering to the rearmost point on the undepressed floor covering on the open tailgate or cargo surface if the rear closure is a conventional door type tailgate at the zero "Y" plane.

L201 CARGO LENGTH-OPEN-SECOND. The dimension measured longitudinally from the back of the second seatback at the height of the undepressed floor covering on the open tailgate or cargo floor surface if the rear closure is a conventional door type tailgate, at the zero "Y" plane.

L202 CARGO LENGTH-CLOSED-FRONT. The minimum dimension measured horizontally from the back of the front seat at the height of the undepressed floor covering to the rearmost point on the undepressed floor covering on the closed tailgate or taildoor for station wagons, trucks and mpv's at the zero "Y" plane.

L203 CARGO LENGTH-CLOSED-SECOND. The dimension measured horizontally from the back of the second seat at the height of the undepressed floor covering to the rearmost point on the undepressed floor covering on the closed tailgate or taildoor for station wagons, trucks and mpv's at the zero "Y" plane.

L204 CARGO LENGTH AT BELT-FRONT. The minimum dimension measured horizontally from the back of the front seatback at the seatback top to the foremost normal surface of the closed tailgate or inside surface of the cab backpanel at the height of the belt, on the zero "Y" plane.

L205 CARGO LENGTH AT BELT-SECOND. The minimum dimension measured horizontally from the back of the second seatback top to the foremost normal surface of the closed tailgate at the height of the belt, on the zero "Y" plane.

W201 CARGO WIDTH-WHEELHOUSE. The minimum dimension measured laterally between the trimmed wheelhousings at floor level. For any vehicle not trimmed, measure to the sheet metal.

W203 REAR OPENING WIDTH AT FLOOR. The minimum dimension measured laterally between the limiting interferences of the rear opening at floor level.

W204 REAR OPENING WIDTH AT BELT. The minimum dimension measured laterally between the limiting interferences of the rear opening at belt height or top of pick up box.

W205 REAR OPENING WIDTH ABOVE BELT. The minimum dimension measured laterally between the limiting interferences of the rear opening above the belt height.

W500 CARGO WIDTH AT FLOOR. The maximum dimension measured laterally between the limiting interferences at the floor level. This dimension shall include ribs and pillars, but will exclude wheelhouses.

H197 FRONT SEATBACK TO LOAD FLOOR HEIGHT. The dimension measured vertically from the horizontal tangent to the top of the seatback to the undepressed floor covering.

H201 CARGO HEIGHT. The dimension measured vertically from the top of the undepressed floor covering to the headlining at the rear wheel "X" coordinate on the zero "Y" plane.

H202 REAR OPENING HEIGHT. The dimension measured vertically from the top of the undepressed floor covering to the upper trimmed opening on the zero "Y" plane with rear door fully open.

H250 TAILGATE TO GROUND CURB MASS (WT.) The dimension measured vertically from the top of the undepressed floor covering on the lowered tailgate to ground on the zero "Y" plane.

H505 MAXIMUM CARGO HEIGHT. The maximum vertical dimension rear of the front seat from the cargo floor to roof bow or headlining at the zero "Y" plane.

Specifications

METRIC

Interior Vehicle And Body Dimensions - Key Sheet

Dimensions Definitions

<p>V2 STATION WAGON Measured in inches:</p> $\frac{W4 \times H201 \times L204}{1728} - ft^3$ <p>Measured in mm:</p> $\frac{W4 \times H201 \times L204}{10^9} - m^3(cubicmeter)$	<p>L208 CARGO LENGTH AT FRONT SEATBACK HEIGHT. The minimum horizontal dimension from the "X" plane tangent to the rearmost surface of the driver's seatback to the inside limiting interference of the hatchback door on the vehicle zero "Y" plane.</p> <p>L209 CARGO LENGTH AT FLOOR-FRONT. The minimum horizontal dimension measured at floor level from the rear of the front seatback to the normal limiting interference of the hatchback door on the vehicle zero "Y" plane.</p> <p>L210 CARGO LENGTH AT SECOND SEATBACK HEIGHT. The minimum dimension measured from the "X" plane tangent to the rearmost surface of second seatback or the load floor which is towed at least one half of the H198 dimension height above the rear load floor, to the rearmost inside limiting interference on the zero "X" plane.</p> <p>L211 CARGO LENGTH AT FLOOR-SECOND SEATBACK. The minimum horizontal dimension measured at floor level from the rear of the second seatback or load floor panel to the normal limiting interference of the hatchback door on the vehicle zero "Y" plane.</p> <p>H197 FRONT SEATBACK TO LOAD HEIGHT. The dimension measured vertically from the horizontal tangent to the top of the seatback to the undepressed floor covering.</p> <p>H198 SECOND SEATBACK TO LOAD FLOOR HEIGHT. The dimension measured vertically from the second seatback to the undepressed floor covering.</p> <p>V3 HATCHBACK. Measured in inches:</p> $\frac{L208 - L209}{2} \times W4 \times H197 - ft^3$ <p>Measured in mm:</p> $\frac{L208 - L209}{2} \times W4 \times H197 - m^3(cubicmeter)$
<p>V4 HIDDEN LUGGAGE CAPACITY-REAR OF FRONT SEAT. The total volumes of individual pieces of one set of standard luggage stowed in any hidden cargo area below the load floor rear of the front seat.</p> <p>V5 TRUCKS AND MPV'S WITH OPEN AREA. Measured in inches:</p> $\frac{L506 \times W505 \times H503}{1728} - ft^3$ <p>Measured in mm:</p> $\frac{L506 \times W505 \times H503}{10^9} - m^3(cubicmeter)$	<p>V4 HIDDEN LUGGAGE CAPACITY-REAR OF FRONT SEAT. The total volumes of individual pieces of one set of standard luggage stowed in any hidden cargo area below the load floor rear of the front seat.</p> <p>V11 HATCHBACK CARGO VOLUME INDEX. Usable luggage (one (1) stand and luggage set) below floor: Measured in inches:</p> $\frac{L210 - L211}{2} \times W4 \times H198 - ft^3$ <p>Measured in mm:</p> $\frac{L210 - L211}{2} \times W4 \times H198 - m^3(cubicmeter)$
<p>V6 TRUCKS AND MPV'S WITH CLOSED AREA. Measured in inches:</p> $\frac{L204 \times W500 \times H505}{1728} - ft^3$ <p>Measured in mm:</p> $\frac{L204 \times W500 \times H505}{10^9} - m^3(cubicmeter)$	<p>V8 HIDDEN LUGGAGE CAPACITY-REAR OF SECOND SEAT. The total volume of individual pieces of one set of standard luggage stowed in any hidden cargo area below the load floor rear of the second seat.</p> <p>V10 STATION WAGON CARGO VOLUME INDEX. Measured in inches:</p> $\frac{H201 \times L205 \times \frac{W4 - W201}{2}}{1728} - ft^3$ <p>Measured in mm:</p> $\frac{H201 \times L205 \times \frac{W4 - W201}{2}}{10^9} - m^3(cubicmeter)$

Hatchback - Cargo Space Dimensions

All Hatchback cargo dimensions are to be taken with the front seat in full down and rear position, and the rear seat folded down. The hatchback door is in the closed position. (For electronically adjusted seats, see the manufacturer's specifications for Design "H" Point).



1
2
3



Specifications

METRIC

Index

Subject	Page No.	Subject	Page No.
Alternator	16	Origin	1
Axle, Drive, Front, Rear, All Four	2, 9, 10	Passenger Capacity	1
Axle Shafts	10	Passenger Mass Distribution	26
Battery	16	Pistons	3
Body and Miscellaneous Information	17	Power Brakes	12
Brakes-Parking Service	12, 13	Power Engine	2
Camber	15	Power Steering	14
Camshaft	3	Power Teams	2
Capacities		Propeller Shaft	10
Cooling System	5	Pumps-Fuel	6
Fuel Tank	6	Water	5
Lubricants		Radiator-Cap, Hoses, Core	5
Engine Crankcase	4	Ratios-Axle, Transaxle	2,9,10
Transmission/Transaxle	8,9	Compression	2
Rear Axle	10	Steering	14
Carburetor	2,6	Transmission/Transaxle	2,8,9
Caster	15	Rear Axle	2,10
Climate Control System	19	Regulator-Alternator	16
Clutch-Pedal Operated	8	Restraint System	18
Coil, Ignition	16	Rims	13
Connecting Rods	4	Rods-Connecting	4
Convenience Equipment	20-21	Scrub Radius	14
Cooling System	5	Seats	17
Crankshaft	4	Shock Absorbers, Front & Rear	11
Cylinders and Cylinder Head	3	Spark Plugs	16
Diesel Information	4	Speedometer	15
Dimension Definitions		Springs-Front & Rear Suspension	11
Key Sheet-Exterior	28,31,32	Stabilizer (Sway Bar)-Front & Rear	11
Key Sheet-Interior	29,30,32,33,34	Starting System	16
Electrical System	15,16	Steering	14
Emission Controls	7	Suppression-Ignition, Radio	16
Engine-General		Suspension-Front & Rear	11
Bore, Stroke, Type	3	Tail Pipe	7
Compression Ratio	2	Theft Protection	21
Displacement	2,3	Thermostat, Cooling	5
Firing Order, Cylinder Numbering	3	Tires	13
General Information, Power & Torque	2	Toe-In	15
Intake System	4	Torque Converter	9
Power Teams	2	Torque-Engine	2,8,9
Exhaust System	7	Trailer Towing	21
Equipment Availability, Convenience	20	Transaxle	9
Fan, Cooling	5	Transmission-Types	2,8,9
Filters - Engine Oil, Fuel System	4	Transmission-Automatic	2,9
Four Wheel Drive	10	Transmission-Manual	2,8
Frame	17	Transmission-Ratios	2,8,9
Front Suspension	11	Tread	22
Front Wheel Drive Unit	10	Trunk Cargo Load	1
Fuel Economy, EPA	1	Trunk Luggage capacity	23
Fuel Injection	6	Turning Diameter	14
Fuel System	6	Unitized Construction	18
Fuel Tank	6	Universal Joints, Propeller Shaft	10
Glass	18	Valve System	4
Headlamps	18	Vehicle Dimensions	
Headroom-Body	23,24	Width	22
Heights	22	Length	22
Horns	15	Height	22
Horsepower-Brake	2	Ground Clearance	22
Ignition System	16	Front Compartment	23
Inflation-Tires	13	Rear Compartment	23
Interior Volumes	23	Luggage Compartment	23
Instruments	15	Station Wagon-Third Seat	24
Legroom	23,24	Station Wagon-Cargo Space	24
Lengths	22	Hatchback-Cargo Space	24
Leveling,Suspension	11	Fiducial Marks	25
Lifters, Valve	4	Voltage Regulator	16
Linings-Clutch, Brake	8,12	Water Pump	5
Lubrication-Engine Transmission/Transaxle	4,8,9	Weights	26,27
Luggage Compartment	23	Wheel Alignment	15
Models	1	Wheelbase	22
Motor Starting	16	Wheels & Tires	13
Muffler	7	Wheel Spindle	14
		Widths	22
		Windshield	18
		Windshield Wiper and Washer	15

