

1999

CHEVROLET
ASTRO VAN

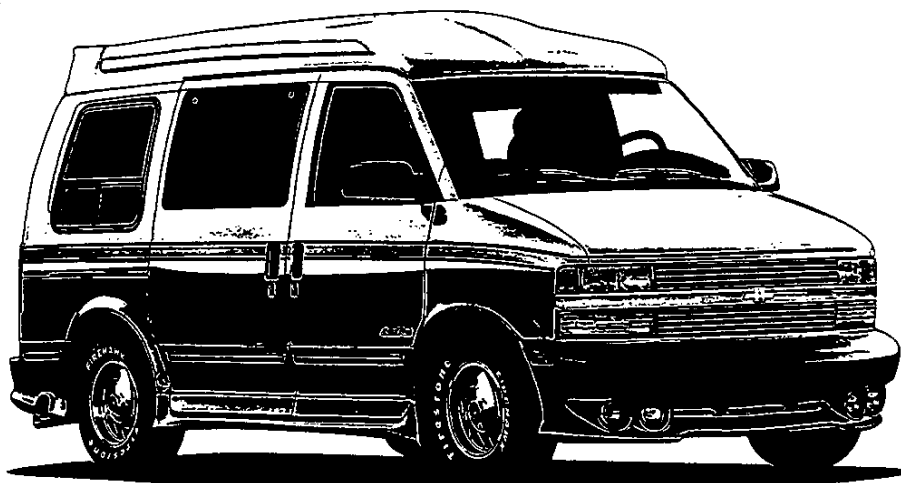



For Release: August 1, 1998

Contact: Chevrolet Communications
Chevrolet Media Online: <http://media.gm.com/chevy>
Phone: 1-800-CHEVY-MI
Fax: 800-504-5073

1999 CHEVY ASTRO, AN INDUSTRY EXCLUSIVE, OFFERS NEW ALL-WHEEL DRIVE SYSTEM

DETROIT — For the second straight year, Chevy Astro rear-wheel-drive midsize van remains one of the few choices for buyers who need more room and capability than typical front-wheel-drive minivans, but don't want the bulk of a full-size van.

"Astro provides one of the few alternatives to van buyers," says John Gaydash, Astro brand manager. "No minivan can match it for cargo capacity, trailering capability and comfortable seating for eight adults."

Astro is able to fit a diverse group of customers' needs because of its versatility. It is available in either passenger or cargo versions, and in rear-wheel-drive or All-Wheel-Drive configurations.

1999 Astros feature a number of refinements.

For example, a new "state of the art" All-Wheel-Drive active transfer case replaces the previous All-Wheel-Drive (AWD) system. Astro will operate in two-wheel drive until the system senses rear wheel slippage. It then immediately transfers torque between the front and rear axle to help regain traction and optimize control.

The standard 4L60-E four-speed automatic overdrive transmission has been enhanced for '99. It now provides better sealing with new pump cover seals. In addition, a new clutch plate material is designed to improve clutch durability and performance.

This transmission is matched with the powerful Vortec 4300 V6 SFI engine (190 horsepower @ 4400 rpm, 250 lb.-ft. of torque at 2800 rpm) to provide best in class trailering — up to 5,500 lbs. when properly equipped. Ford and Chrysler minivans top out at 3,500 lbs.

Astro's interior is designed for versatility, comfort and convenience. New for '99, an available roof console with a trip computer provides instantaneous and average fuel economy, trip range, fuel used and elapsed time — perfect for tracking mileage on family vacations. The console is standard with LS and LT trim levels. The LT trim level also includes eight-passenger seating, six-way power driver seat, power mirrors, Remote Keyless Entry and more.

- MORE -

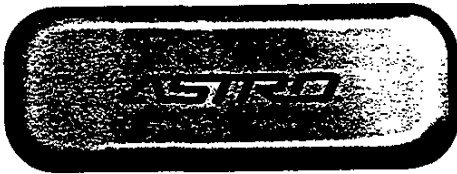

1999 CHEVROLET ASTRO



ASTRO CARGO VAN

This hard-working van is for cost-conscious fleet managers, small business owners and tradespeople. No compact cargo van can carry more than Astro.* Astro Cargo Van provides users with a unique combination of size, capacity, maneuverability and long-lasting dependable service at an efficient operating cost.

Competitors:

- Ford Windstar (FWD) Cargo Van

Demographics:

- Typical buyers are commercial users and fleets, which include building, remodeling, plumbing, electrical, security and pickup and delivery

Sales for the 1997 model were 37,347 units.

*Excludes other GM vehicles.

MODEL/TRIM LEVELS

- Passenger Van, rear-wheel drive
- Passenger Van, All-Wheel-Drive
- Cargo Van, rear-wheel drive
- Cargo Van, All-Wheel-Drive

Three trim levels are available for Astro Passenger Van:

- Astro (with standard trim)
- LS
- LT.

Astro Cargo Van is available only in the standard trim level.

ASTRO PASSENGER VAN (WITH STANDARD TRIM)

Interior features:

- Air conditioning
- Next Generation driver and front-passenger air bags*
- Passlock® theft-deterrent system
- Delayed-entry interior lights
- Scotchgard™ protection (on floor carpeting and all available cloth seats and trim)
- Passenger assist handles
- Cup holders

- Three auxiliary power outlets (two up front, one in back).
- Intermittent variable windshield wipers.

Exterior:

- Daytime Running Lamps (DRL)
- Two-side galvanized steel body panels (except roof).

Functional:

- Vortec 4300 V6 engine
- Electronically controlled 4-speed automatic overdrive transmission (4T60-E)
- 4-wheel antilock brake system (ABS)
- Power front disc/rear drum brakes
- Power rack-and-pinion steering
- 4-wheel independent suspension
- 100,000-mile platinum-tip spark plugs†
- 150,000-mile extended-life engine coolant†
- 15-inch steel wheels.

*Always use safety belts and proper child restraints, even with Next Generation air bags. See the Owner's Manual for more safety information.

ASTRO LS PASSENGER VAN

Astro LS adds:

Interior:

- 8-passenger seating in Custom Cloth
- Sunshades with illuminated vanity mirrors
- Tilt-Wheel™ steering column and electronic speed control.
- Cargo convenience net
- Solar-Ray deep-tinted glass
- Overhead console with electronics
- Power door locks and windows.

Exterior:

- Body-side cladding
- Power mirrors.

ASTRO LT PASSENGER VAN

LT adds:

Interior:

- 8-passenger seating trimmed in Special Cloth
- 6-way power driver seat
- Overhead console with trip computer
- Sunshades with illuminated vanity mirrors
- Power mirrors
- Power windows

1999 CHEVROLET ASTRO

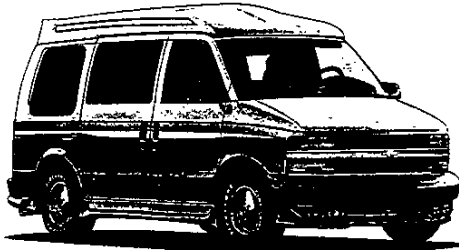

Astro LT All-Wheel-Drive

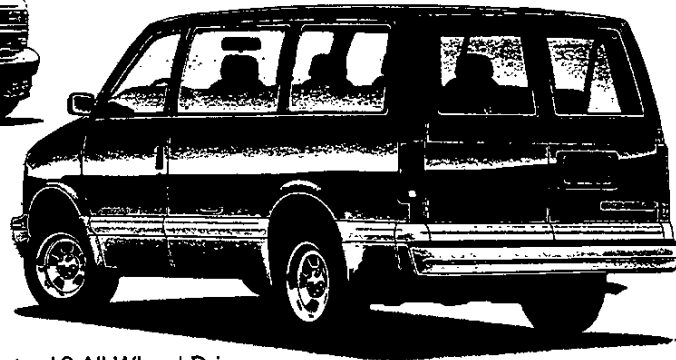

Astro LS All-Wheel-Drive

ASTRO AND THE MARKETPLACE

ASTRO PASSENGER VAN

This versatile van is the logical midsize van choice for recreationally active families who need the capabilities only Astro can provide: versatility and truck-like attributes (towing power, cargo room and an available AWD model).

For 1999, Astro offers more cargo capacity, payload capacity and a higher trailer towing rating than any typical front-wheel-drive minivan. And it's truck tough.

Competitors:

- Ford Windstar
- Dodge Caravan and Grand Caravan/Plymouth Voyager and Grand Voyager
- Mazda MPV

Demographics:

- Typical buyers are 25 to 55 years of age
- Median income of \$50,000
- Predominantly married with children and college graduates

Sales for the 1997 model year were 79,248 units.

NEW FOR 1999

INTERIOR

- Roof console with electronics (page 5).

EXTERIOR

- Two new exterior colors: Medium Charcoal Gray Metallic and Medium Bronzemist Metallic (page 7).

- New stripe design and two new stripe colors for LT trim: Silvermist and Bronzemist Metallic (page 7).
- Optional running boards (page 7).

TRANSMISSIONS

- Automatic transmission enhancements (page 9).
- "State of the art" active transfer case on AWD models (page 9).

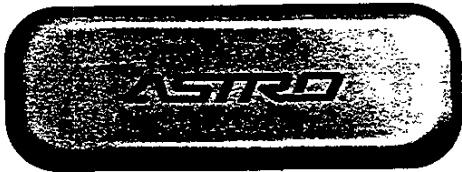

SAFETY AND SECURITY

CRASH AVOIDANCE FEATURES

- **DAY-TIME RUNNING LAMPS (DRL)** turn on automatically* when shifting the vehicle from "Park" and when the ignition is on. With DRL, the headlamps operate at reduced intensity to increase Astro's visibility to other drivers. The DRL system is overridden when the vehicle's headlamps are engaged.
- **4-WHEEL ANTILOCK BRAKE SYSTEM (ABS)**, automatically adjusts brake pressure to the front and rear wheels during hard braking situations, to help the driver maintain steering control and reduce wheel lockup. All the driver has to do is keep firm pressure on the brake pedal and steer.
- **BRAKE TRANSMISSION SHIFT INTERLOCK**, a feature of the automatic transmission, requires drivers to depress the brake pedal to shift out of Park.
- **SLOPING HOOD DESIGN** and large windshield contribute to road visibility.

*Parking brake must be disengaged for the system to activate.

STANDARD OCCUPANT PROTECTION FEATURES

- **NEXT GENERATION DRIVER AND FRONT-PASSENGER AIR BAGS*** are designed to supplement safety belts, helping to restrain front-seat occupants in the event of a moderate to severe frontal impact.
- **THREE-POINT ENERGY-ABSORBING SAFETY BELT SYSTEM** helps restrain outboard passengers by distributing forces to help reduce the risk of injury.
- **REAR-SEAT (OUTBOARD SEATS) SAFETY BELT CHILD COMFORT GUIDES** adjust the angle of safety belt crossover, making safety belts more comfortable for older children and smaller sized adults riding in the intermediate or rear seats.

- **CHILD SECURITY SLIDING-DOOR LOCK**, positioned on the front of the sliding door, prevents the lock from being opened from the inside when it is engaged.
- **REINFORCED SAFETY-CAGE** construction surrounds occupants with a cocoon-like system of structural components. This structure consists of reinforced roof rails, door pillars and beams designed to help minimize intrusion into the passenger compartment.
- **FRONT AND REAR CRUSH ZONES** are designed to deform in a controlled manner in the event of a collision to help absorb impact energy to reduce intrusion into the passenger compartment.
- **ENERGY-ABSORBING STEERING COLUMN AND INSTRUMENT PANEL** are designed to help absorb collision impact, to help reduce the risk of injury to the driver.

*Always use safety belts and proper child restraints, even with Next Generation air bags. See the owner's manual for more safety information.

SECURITY FEATURES

- **PASSLOCK THEFT-DETERRENT SYSTEM** is totally passive. If an attempt is made to start the vehicle without the proper key, the fuel system is disabled.
- **REMOTE KEYLESS ENTRY** (optional with LS and base-level, standard on LT transmits a uniquely coded signal to activate power lock/unlock functions, as well as illuminated entry.
- **HOMELINK 3-CHANNEL TRANSMITTER**, optional on base-level, LS and LT models with available roof console, memorizes the activation codes for up to three remote-control devices (such as garage door, gate and security lights) to help promote personal security.

1999 CHEVROLET ASTRO

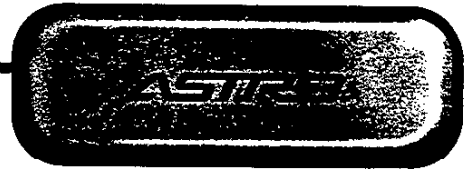

- Remote Keyless Entry
- Leather-wrapped steering wheel
- Painted luggage carrier.

ASTRO CONVERSION VAN

Chevrolet offers a comprehensive Upfitter Package (RPO YF7) for Astro that provides authorized van converters with a well equipped basic vehicle, ready to receive the custom features and touches that enhance the enjoyment of Astro as an ideal vehicle for recreation and travel.

ASTRO CARGO VAN

Astro Cargo Van combines the inherent toughness of a Chevy truck and the nimble handling and efficiency of a minivan with the spacious midsize van roominess only Astro can offer. What's more, the available AWD models adds still further to this versatile van's appealing work credentials.

Interior

- Air conditioning
- Passlock® theft-deterrent system
- Next Generation driver and front-passenger air bags*
- Cup holders
- Intermittent windshield wipers
- Two front auxiliary power outlets

Exterior

- Daytime Running Lamps (DRL)†
- Two-side galvanized steel body panels (except roof).

Functional

- Vortec 4300 V6 engine
- Electronically controlled 4-speed automatic overdrive transmission (4T60-E)
- 4-wheel antilock brake system (ABS)
- Power front disc/rear drum brakes
- Power rack-and-pinion steering
- 4-wheel independent suspension (RWD)
- 100,000-mile platinum-tip spark plugs†
- 150,000-mile extended-life engine coolant†
- 15-inch steel wheels.

*Always use safety belts and proper child restraints, even with Next Generation air bags. See the owner's manual for more safety information. †Parking brake must be disengaged for the system to activate.

THE CHEVROLET FAMILY OF VANS

Chevrolet offers six distinctly styled vans with several equipment levels, the broadest combination of any manufacturer in the industry. These vans provide customers broad options in size, power, economy and utility.

NOTE: The Chevy Van name has been replaced by Chevy Express Cargo Van for the 1999 model year.

CHEVY EXPRESS PASSENGER VAN — With seating for up to 15 people, Chevy Express Passenger Van is the ideal people-mover and cargo-hauler. It serves both commercial and personal applications that require "anything goes" versatility in a full-size van.

CHEVY EXPRESS CARGO VAN — Offering full-size van flexibility and rugged truck durability, Chevy Express Cargo Van provides exceptional comfort, impressive safety features, superior towing capabilities and is ideal for conversion upfitting or big cargo-carrying applications, with as much as 316.8 cu. ft. of cargo room.

ASTRO VAN — Chevy Astro Van (passenger and cargo models) is a versatile workhorse, offering a combination of people-moving (as many as 8 passengers), cargo-carrying (as much as 170.4 cu. ft.) and trailering capabilities (as much as 5,500 lbs., when properly equipped).

VENTURE — Chevy Venture completes the Chevrolet family of vans, offering time-challenged customers optimum flexibility, comfort and convenience, while providing "space on demand," impressive ride and handling and one of the most powerful minivans in its class. Venture is available in Passenger Van and Cargo Van configurations.



1999 CHEVROLET ASTRO



SEATS

- Front passengers are protected by LBP AND SHOULDER SAFETY BELTS AND HEAD RESTRAINTS, while passengers in the intermediate and rear bench seats have lap safety belts, shoulder safety belts and head restraints for the outboard seating positions.
- SPECIAL LEATHER SEATING SURFACES are available on Astro LT models.

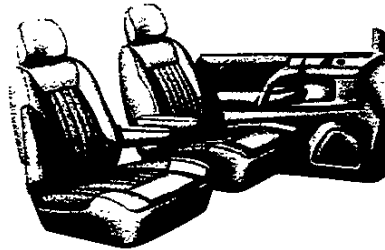

- FRONT RECLINING SPECIAL CLOTH OR SPECIAL LEATHER HIGH-BACK BUCKET SEATS with folding integral armrests and adjustable head restraints. Split-back center- and rear-row seats with fold-down center console, convenience tray and cup holders — standard on LT in Special Cloth, optional on LT with Special Leather seating surfaces.

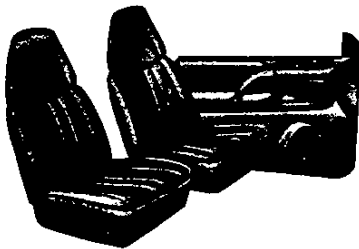

- FRONT HIGH-BACK RECLINING CUSTOM VINYL BUCKET SEATS with 3-passenger center-row bench seat — standard on Astro Passenger Van with standard trim and Cargo Van (which includes only front seats).

Alternate Seating Packages (Passenger Van):

- ZP7 7-passenger seating includes: 4 high-back reclining bucket seats and a 3-passenger adjustable rear-row seat.
- ZP8 8-passenger seating* includes: 2 high-back front reclining bucket seats and two 3-passenger adjustable rear-bench seats.*

*2 split-back rear bench seats with LT trim.

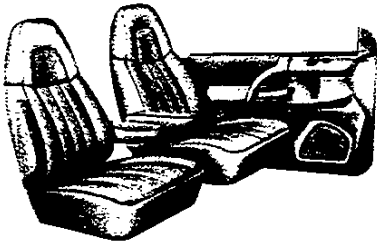

- FRONT HIGH-BACK RECLINING CUSTOM CLOTH ADJUSTABLE BUCKET SEATS with folding integral armrests and adjustable 3-passenger center- and rear-row bench seats — standard on LS, available with standard trim and on Cargo Van (front seats only).

Interior Colors, Cloth, and Leather†:

- Medium Gray
- Blue*
- Neutral
- Red.†

*Not available in special cloth or special leather. (LT models).
†Not available with ZP5 seating.

1999 CHEVROLET ASTRO

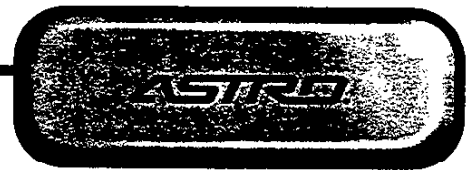

INTERIOR FEATURES

COMFORT/CONVENIENCE FEATURES

Standard

- **ENGINE COVER CONVENIENCE CONSOLE** includes such handy features as dual auxiliary power outlets, dual cup holders, a glove box and a map net.
- **AIR CONDITIONING** uses CFC-free refrigerant. Front air conditioning is standard on all models. Rear air conditioning is optional on all passenger van models.
- **SCOTCHGARD™ PROTECTION** helps protect cloth seating surfaces and floor coverings from stains and makes cleanups easy.
- **INTERMITTENT VARIABLE WINDSHIELD WIPERS** allow the driver to match wiper speed with weather conditions for improved visibility.
- **PASSENGER ASSIST HANDLES** help make vehicle entry and exit easy.
- **WIDE-OPENING REAR AND SIDE DOORS** make loading and unloading easy.
- **DOOR MAP POCKETS** provide convenient storage space.
- **RIBBED LOAD FLOOR** on Astro Cargo Van models helps make sliding heavy cargo easy.

Optional

- **NEW AVAILABLE ROOF CONSOLE WITH NEW TRIP COMPUTER** (standard with LS and LT trim) includes average and instantaneous fuel economy, trip range, fuel consumption and elapsed time. This console is also available without electronics.
- **TILT-WHEEL™ STEERING COLUMN**, standard on LS and LT and optional with standard trim, lets the driver adjust the wheel for easy entry and exit
- **REAR COMPARTMENT CONVENIENCE NET**, standard on LS and LT, helps prevent groceries and other small cargo items from sliding about.

SOUND SYSTEMS

- **ELECTRONICALLY TUNED AM/FM STEREO** with seek-scan, digital clock and six-speaker system, standard on all models.
- **ELECTRONICALLY TUNED AM/FM STEREO WITH CASSETTE PLAYER**, seek-scan and digital clock, available on all models.
- **ELECTRONICALLY TUNED AM/FM STEREO WITH CASSETTE PLAYER**, speed-compensated volume, automatic tone control, seek-scan, digital clock, TheftLock security feature and eight-speaker system, optional on all models.*
- **ELECTRONICALLY TUNED AM/FM STEREO WITH COMPACT DISC PLAYER**, seek-scan, digital clock, automatic tone control, speed-compensated volume, TheftLock and eight-speaker system, optional on all models.*
- **ELECTRONICALLY TUNED AM/FM STEREO WITH CASSETTE PLAYER**, compact disc player, seek-scan, digital clock, automatic tone control, speed-compensated volume, TheftLock and eight-speaker system, optional on all models.*
- **CENTER-ROW RADIO CONTROLS** are available with the uplevel cassette and dual playback cassette/compact disc player systems (not available on base-level models).

*Cargo Van models offer four front-door speakers and rear-speaker wiring.



1999 CHEVROLET ASTRO



ASTRO CARGO VAN

This hard-working van is for cost-conscious fleet managers, small business owners and tradespeople. No compact cargo van can carry more than Astro.* Astro Cargo Van provides users with a unique combination of size, capacity, maneuverability and long-lasting dependable service at an efficient operating cost.

Competitors:

- Ford Windstar (FWD) Cargo Van

Demographics:

- Typical buyers are commercial users and fleets, which include building, remodeling, plumbing, electrical, security and pickup and delivery

Sales for the 1997 model were 37,347 units.

*Excludes other GM vehicles.

- Three auxiliary power outlets (two up front, one in back).
- Intermittent variable windshield wipers.

Exterior:

- Daytime Running Lamps (DRL)
- Two-side galvanized steel body panels (except roof).

Functional:

- Vortec 4300 V6 engine
- Electronically controlled 4-speed automatic overdrive transmission (4T60-E)
- 4-wheel antilock brake system (ABS)
- Power front disc/rear drum brakes
- Power rack-and-pinion steering
- 4-wheel independent suspension
- 100,000-mile platinum-tip spark plugs†
- 150,000-mile extended-life engine coolant†
- 15-inch steel wheels.

†Always use safety belts and proper child restraints, even with Next Generation air bags. See the Owner's Manual for more safety information.

MODEL/TRIM LEVELS

- Passenger Van, rear-wheel drive
- Passenger Van, All-Wheel-Drive
- Cargo Van, rear-wheel drive
- Cargo Van, All-Wheel-Drive

Three trim levels are available for Astro Passenger Van:

- Astro (with standard trim)
- LS
- LT.

Astro Cargo Van is available only in the standard trim level.

ASTRO PASSENGER VAN (WITH STANDARD TRIM)

Interior features:

- Air conditioning
- Next Generation driver and front-passenger air bags*
- Passlock® theft-deterrent system
- Delayed-entry interior lights
- Scotchgard™ protection (on floor carpeting and all available cloth seats and trim)
- Passenger assist handles
- Cup holders

ASTRO LS PASSENGER VAN

Astro LS adds:

Interior:

- 8-passenger seating in Custom Cloth
- Sunshades with illuminated vanity mirrors
- Tilt-Wheel™ steering column and electronic speed control.
- Cargo convenience net
- Solar-Ray deep-tinted glass
- Overhead console with electronics
- Power door locks and windows.

Exterior:

- Body-side cladding
- Power mirrors.

ASTRO LT PASSENGER VAN

LT adds:

Interior:

- 8-passenger seating trimmed in Special Cloth
- 6-way power driver seat
- Overhead console with trip computer
- Sunshades with illuminated vanity mirrors
- Power mirrors
- Power windows

1999 CHEVROLET ASTRO

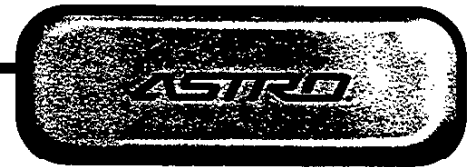

EXTERIOR STRUCTURAL FEATURES

EXTERIOR FEATURES

Standard:

- **TWO-SIDE GALVANIZED STEEL** is used for all major exterior body panels (except the roof, where it is not needed) to help prevent surface rust due to minor chips and scratches.
- **SEVEN-STAGE ZINC PHOSPHATE WASH AND ZINC-RICH CORROSION-RESISTANT PRIMER** further protect the Astro body, door and hood.
- **SPECIAL SEALERS** are applied to body seams for added corrosion protection before final assembly.
- **URETHANE ANTI-CHIP COATING** on all lower body panels (except cladded models) provides added protection against stone damage and road debris, and hot wax is sprayed on the underbody.
- **AN ALUMINIZED STAINLESS-STEEL MUFFLER AND TAILPIPE** designed to provide enhanced durability.

Options:

- **NEW AVAILABLE RUNNING BOARDS**, new for 1999 (optional on all models with body cladding), accents exterior appearance while making entry and exit easy.
- **SMOOTH FRONT FASCIA AND REAR BUMPER**, painted body color, on Astro Cargo Van models with YF7 and standard trim on Astro Passenger Van models.
- **BODY-SIDE CLADDING** provides dramatic styling (standard on LS and LT; optional on Cargo Van models with YF7 Upfitter Package).
- **SOLAR-RAY TINTED GLASS** improves interior comfort and enhances protection against ultraviolet and infrared solar rays (deep tint on LS and LT models).

STRUCTURAL FEATURES

- **BODY INTEGRAL FRAME STRUCTURE** that incorporates a partial front ladder-type stub-frame with the floor panels adds rigidity without excessive weight. This design maximizes strength and payload capacity.
- **SINGLE-PIECE STAMPINGS**, which comprise the underbody, right- and left-side panels, roof panel and front end provide increased structural rigidity.
- **SINGLE-PIECE CONSTRUCTION OF THE FRONT-DOOR FRAMES**, window frames, side- and rear-door openings protects against corrosion by eliminating vulnerable seams.
- **PLASTIC RESIN** in some parts — such as the radiator coolant reservoir, windshield washer reservoir and fuel tank shield — are labeled to facilitate recycling.

EXTERIOR PAINT/COLORS

Standard basecoat/clearcoat paint on Astro resists fading and provides a high gloss shine for long-lasting exterior beauty.

NEW Paint Colors for 99:

- Medium Charcoal Gray Metallic
- Medium Bronzemist Metallic.

NEW Paint Colors for 99:

- Silvermist
- Bronzemist.

Other Colors:

- Ivory White
- Teal Blue Metallic
- Dark Copper Metallic
- Silvermist Metallic
- Light Carmine Red Metallic
- Medium Cadet Blue Metallic
- Dark Forest Green Metallic
- Light Autumnwood Metallic.



SAFETY AND SECURITY

CRASH AVOIDANCE FEATURES

- **DAY-TIME RUNNING LAMPS (DRL)** turn on automatically* when shifting the vehicle from "Park" and when the ignition is on. With DRL, the headlamps operate at reduced intensity to increase Astro's visibility to other drivers. The DRL system is overridden when the vehicle's headlamps are engaged.
- **4-WHEEL ANTILOCK BRAKE SYSTEM (ABS)**, automatically adjusts brake pressure to the front and rear wheels during hard braking situations, to help the driver maintain steering control and reduce wheel lockup. All the driver has to do is keep firm pressure on the brake pedal and steer.
- **BRAKE, TRANSMISSION SHIFT INTERLOCK**, a feature of the automatic transmission, requires drivers to depress the brake pedal to shift out of Park.
- **SLOPING HOOD DESIGN** and large windshield contribute to road visibility.

*Parking brake must be disengaged for the system to activate.

STANDARD OCCUPANT PROTECTION FEATURES

- **NEXT GENERATION DRIVER AND FRONT-PASSENGER AIR BAGS*** are designed to supplement safety belts, helping to restrain front-seat occupants in the event of a moderate to severe frontal impact.
- **THREE-POINT ENERGY-ABSORBING SAFETY BELT SYSTEM** helps restrain outboard passengers by distributing forces to help reduce the risk of injury.
- **REAR-SEAT (OUTBOARD SEATS) SAFETY BELT CHILD COMFORT GUIDES** adjust the angle of safety belt crossover, making safety belts more comfortable for older children and smaller sized adults riding in the intermediate or rear seats.

- **WORLD SECURITY SLIDING-DOOR LOCK**, positioned on the front of the sliding door, prevents the lock from being opened from the inside when it is engaged.
- **REINFORCED SAFETY-CAGE** construction surrounds occupants with a cocoon-like system of structural components. This structure consists of reinforced roof rails, door pillars and beams designed to help minimize intrusion into the passenger compartment.
- **FRONT AND REAR CRUSH ZONES** are designed to deform in a controlled manner in the event of a collision to help absorb impact energy to reduce intrusion into the passenger compartment.
- **ENERGY-ABSORBING STEERING COLUMN AND INSTRUMENT PANEL** are designed to help absorb collision impact, to help reduce the risk of injury to the driver.

*Always use safety belts and proper child restraints, even with Next Generation air bags. See the owner's manual for more safety information.

SECURITY FEATURES

- **PASSLOCK™ THEFT-DETERRENT SYSTEM** is totally passive. If an attempt is made to start the vehicle without the proper key, the fuel system is disabled.
- **REMOTE KEYLESS ENTRY** (optional with LS and base-level, standard on LT transmits a uniquely coded signal to activate power lock/unlock functions, as well as illuminated entry.
- **HOMELINK 3-CHANNEL TRANSMITTER**, optional on base-level, LS and LT models with available roof console, memorizes the activation codes for up to three remote-control devices (such as garage door, gate and security lights) to help promote personal security.

1999 CHEVROLET ASTRO



TRANSMISSIONS

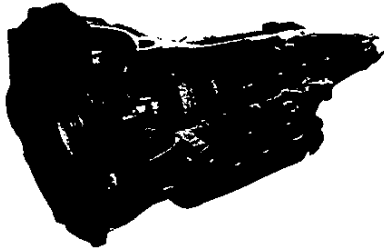

4L60-E 4-SPEED ELECTRONIC AUTOMATIC TRANSMISSION

GM's 4L60-E 4-speed automatic overdrive transmission is standard equipment on Astro. The 4L60-E's "intelligent" electronic controls allow the transmission to match the engine's performance, delivering outstanding fuel-efficiency.

4L60-E new features:

- NEW** VAMAC PUMP COVER SEALS provide for better sealing.
- NEW** CLUTCH PLATE MATERIAL is designed to improve durability and performance.

Other 4L60-E features:

- **WIDE RANGE OF GEAR RATIOS** in the 4L60-E enhances both performance and fuel economy. The 3.06:1 first-gear ratio provides high torque multiplication for initial acceleration. The overdrive 0.70:1 fourth gear lowers engine rpm at highway speeds, providing enhanced fuel economy and minimizing wear.
- **POWERTRAIN CONTROL MODULE (PCM)** in the 4L60-E provides precision and flexibility. It measures key vehicle input, including throttle position, vehicle speed, gear range, temperature and engine load. Four solenoids connected to the PCM control shift points and help promote shift smoothness.

- **VIRTUALLY SEAMLESS OPERATION** is made possible, since the PCM acts as an interface between the engine and transmission.
- **SHIFT-TIMING** is controlled electronically by signals sent to the valve body's shift solenoids, which activate the shift valves and execute the gear changes.
- **BRAKE/TRANSMISSION SHIFT INTERLOCK** is standard. The interlock requires the driver to apply the brake pedal to shift out of Park.
- **SECOND-GEAR-START FEATURE** provides an extra measure of control in hazardous driving conditions. The driver can reduce torque to the drive wheels by moving the gear selector to the Drive 2 position, thereby increasing control during initial acceleration on slippery surfaces.
- **AUTOMATIC TRANSMISSION FLUID** in the 4L60-E has a fluid change interval of 50,000 miles* under normal operating conditions.

*Maintenance needs vary with different uses and driving conditions. See owner's manual for more information.

ALL-WHEEL-DRIVE SYSTEM

- NEW** STATE-OF-THE-ART ALL-WHEEL-DRIVE SYSTEM
The vehicle will normally operate in 2WD until the system senses rear wheel slip, at which time it will transfer torque to the front axle.
- NEW** TRANSFER CASE ASSEMBLY, CONTROL MODULE AND ELECTRICAL HARNESS are the system's components.



1999 CHEVROLET ASTRO



SEATS

- Front passengers are protected by LAP AND SHOULDER SAFETY BELTS AND HEAD RESTRAINTS, while passengers in the intermediate and rear bench seats have lap safety belts, shoulder safety belts and head restraints for the outboard seating positions.
- SPECIAL LEATHER SEATING SURFACES are available on Astro LT models.

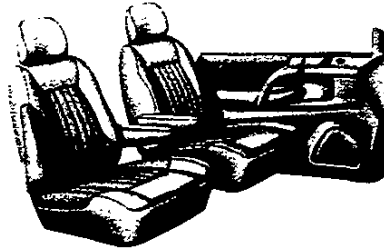

- FRONT HIGH-BACK RECLINING CUSTOM VINYL BUCKET SEATS with 3-passenger center-row bench seat — standard on Astro Passenger Van with standard trim and Cargo Van (which includes only front seats).

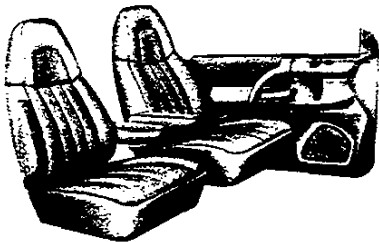

- FRONT HIGH-BACK RECLINING CUSTOM CLOTH ADJUSTABLE BUCKET SEATS with folding integral armrests and adjustable 3-passenger center- and rear-row bench seats — standard on LS, available with standard trim and on Cargo Van (front seats only).

- FRONT RECLINING SPECIAL CLOTH OR SPECIAL LEATHER HIGH-BACK BUCKET SEATS with folding integral armrests and adjustable head restraints. Split-back center- and rear-row seats with fold-down center console, convenience tray and cup holders — standard on LT in Special Cloth, optional on LT with Special Leather seating surfaces.

Alternate Seating Packages (Passenger Van):

- ZP7 7-passenger seating includes: 4 high-back reclining bucket seats and a 3-passenger adjustable rear-row seat.
- ZP8 8-passenger seating* includes: 2 high-back front reclining bucket seats and two 3-passenger adjustable rear-bench seats.*

*2 split-back rear bench seats with LT trim.

Interior Colors, Cloth and Leather:

- Medium Gray
- Blue*
- Neutral
- Red.†

*Not available in special cloth or special leather. (LT models).

†Not available with ZP5 seating.

1999 CHEVROLET ASTRO



WHEELS AND TIRES

WHEELS



- 15" STANDARD STEEL, painted argent with bright hubcap.



- 15" x 6.5" STYLED-STEEL, painted (optional on base-level Astro).

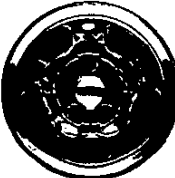

- 15" x 6.5" CHROME-CLADDED STYLED-STEEL (standard on LS with 1SC, optional on other models).



- 15" x 6.5" BRUSHED-ALUMINUM (optional on base-level Cargo Van with YF7 Upfitter Package and LS with PEG 1SD and standard on LT).

TIRES

- P215 75R-15 blackwall all-season steel-belted radials.
- OPTIONAL P215 75R-15 white outline-lettered all-season steel-belted radials.
- OPTIONAL P235 65R-15 white outline-lettered all-season steel-belted radials (included and available only with FE2 Touring Suspension Package).

HISTORY

(BY MODEL YEAR)

- 1985 — Introduced as a midsize alternative to minivans.
- 1986 — Throttle-body fuel injection on 4.3 Liter V6.
- 1987 — New Touring Package; serpentine belt engine accessory drive.
- 1988 — Anti-corrosion improvements.
- 1989 — Rear-wheel antilock brakes and electronic speedometer; Goodyear GT+4 tires available.
- 1990 — All-Wheel-Drive passenger and conversion vans; Extended Wheelbase models debut; four-wheel antilock brakes; increased standard equipment for all trim levels.
- 1991 — 4.3 Liter V6 engine with EFI increased to 170 horsepower.
- 1992 — Enhanced 4.3 Liter V6 engine — optional on 2WD, standard on AWD; optional Dutch doors.
- 1993 — Electronically controlled 4L60-E transmission introduced.
- 1994 — Side door beams; driver air bag; CFC-free R-134a air conditioning refrigerant introduced.
- 1995 — New front-end appearance; standard enhanced Vortec 4.3 Liter V6 with Central Port Fuel Injection.
- 1996 — New interior; passenger-side air bag added; improved Vortec 4300 V6.
- 1997 — Daytime Running Lamps (DRL).*
- 1998 — Next Generation air bags; Passlock® theft-deterrent system; etch-resistant clearcoat paint.

*Parking brake must be disengaged for the system to activate.



1999 CHEVROLET ASTRO



DESIGN AND MANUFACTURING

Astro is manufactured at a General Motors assembly plant in Baltimore, Maryland. There, a precise combination of design technology, sophisticated assembly and statistical process control combine to assure Astro quality.

Key production objectives include:

- **EXTENSIVE USE OF ROBOTICS IN WELDING, PAINTING AND OTHER AREAS**, which provide a high degree of production consistency.
- **COMPUTERIZED TORQUE MONITORING SYSTEM**, which verifies the correct tightening of critical nuts and bolts in the assembly process.
- **HIGH-TECH PRODUCTION METHODS** translate into snug fits throughout the body, strong, seamless welds and a rich, superb-quality paint finish.

ENGINE

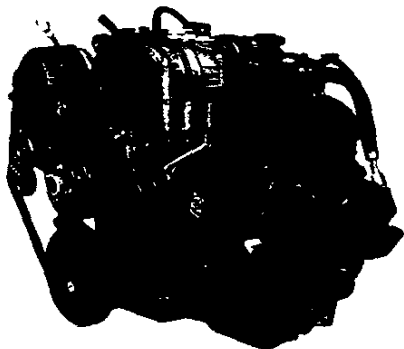

VORTEC 4300 V6 ENGINE (L35)

Vortec 4300 V6 engine with Sequential Fuel Injection (SFI) is standard on Astro. This refined V6 is the largest displacement engine in its class.

Key ratings for the 4300 V6 engine:

- **190 HORSEPOWER** at 4400 rpm
- **250 LB.-FT. OF TORQUE** at 2800 rpm.

4300 V6 TECHNICAL FEATURES

- **SEQUENTIAL FUEL INJECTION, (SFI)** standard on all 1999 Astro models, optimizes fuel economy, power output and meets today's stringent emissions control requirements.
- **HIGH PRECISION FUEL CONTROL**, which uses one injector and nozzle per cylinder for optimum cylinder-to-cylinder fuel distribution.
- **EACH INJECTOR IS FIRED SEQUENTIALLY** and timed to the intake cycle for accuracy and metering control. (With non-SFI engines, fuel is injected once per engine revolution through all injectors at the same time.) Timing is much more precise, thus performance is improved across the board.
- **MASS AIRFLOW METER** constantly measures the engine's air requirements under varying conditions, such as changes in load, altitude and temperature. In a SFI system, the mass airflow meter is essential for accurate fuel delivery.
- **INJECTOR NOZZLE'S DESIGN** and optimum location produce an effective spray pattern that contributes to the engine's smooth idle and outstanding fuel-efficiency.
- **PLATINUM-TIP SPARK PLUGS** help Vortec engines travel up to 100,000 miles* before their first scheduled tune-up
- **ENGINE TIMING** — no need to check — ever
- **EXTENDED-LIFE ENGINE COOLANT** is good for up to 5 years or 150,000 miles,* whichever comes first*
- **SINGLE ACCESSORY DRIVE BELT** helps reduce replacement costs compared to traditional belt designs.

*Maintenance needs vary with different uses and driving conditions. See owner's manual for more information.

1999 CHEVROLET ASTRO

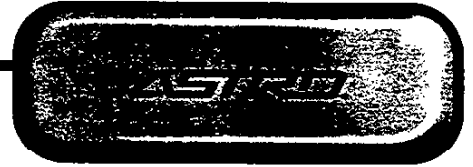

COURTESY TRANSPORTATION

Retail customers who purchase or lease a 1999 Chevrolet car or truck are eligible for Courtesy Transportation when their vehicles are left at a participating dealership for repairs covered under the 3-year/36,000-mile, whichever comes first. New Vehicle Limited Warranty. Courtesy Transportation, at participating dealerships only, may include shuttle service, expense reimbursement or, if the repairs require leaving the vehicle overnight, alternate transportation. Actual services may vary at the election of the participating dealer. Owners should see their dealer for details.

ROADSIDE ASSISTANCE*

Roadside Assistance service is provided through a toll-free 800 number, 24 hours a day, 365 days a year. Roadside Assistance advisors can assist with minor mechanical concerns over the phone or coordinate a variety of services through professional service providers.

Basic Care provides:

- Toll-free access — 1-800-CHEV-USA
- Free towing to closest dealer for warranty repairs
- Basic over-the-phone technical advice
- Dealer services at reasonable costs (i.e., wrecker services, locksmith/key service, glass repair, etc.).

Courtesy Care, which applies for 3 years/36,000-miles* provides:

- Basic Care services
- Free locksmith/key service (when keys are lost on the road or locked inside)
- Free flat tire change service
- Free fuel delivery
- Free non-warranty towing
- Free jump start.

* Roadside Assistance membership is free. Some services may incur costs. Courtesy Care is available to retail, retail lease and corporate lease customers operating 1994 and newer Chevrolet vehicles for a period of 3 years/36,000 miles, whichever comes first. All Courtesy Care services and associated costs must be prearranged by Chevrolet Roadside Assistance or dealer service management and must be driver-initiated. Basic Care and Courtesy Care are not part of or included in the coverage provided by the New Vehicle Limited Warranty. Chevrolet reserves the right to modify or discontinue Basic Care and Courtesy Care at any time. Owners should see their dealer for complete details of the Chevrolet Roadside Assistance Program. †Whichever comes first.

Important — a word about this document: We have tried to make this document as comprehensive and factually accurate as possible. We reserve the right, however, to make changes at any time, without notice, in the information contained in this document. Some information may have been updated since the time of printing in June, 1998.

A note about air bags: Always use safety belts and proper child restraints, even with Next Generation air bags. See the owner's manual for more safety information.

Some artwork contained within this text is for representation purposes only.

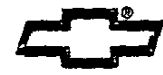

SUSPENSION

FRONT

In keeping with its versatile nature, Astro offers different suspensions tailored to specific customer needs.

- **TORSION BARS** on All-Wheel-Drive models use micro-alloyed spring steel that eliminates torsion bar adapter tubes — reducing mass and contributing to overall fuel economy.
- **FLUID DRAIN PLUG** on the differential carrier makes service easy.
- All-Wheel-Drive models feature **UPPER AND LOWER CONTROL ARMS**, a stabilizer bar and torsion bars computer-selected to optimize ride and handling.
- Rear-wheel-drive models feature an **R-DEPENDENT FRONT SUSPENSION** with upper and lower control arms, a stabilizer bar and computer-selected, friction-free coil springs.
- **SPECIALLY TUNED 32-IN DEFLECTED DISC SHOCK ABSORBERS** are standard on RWD and AWD models.

REAR

- **REAR AXLE SHAFTS** are hardened for fatigue-resistance and durability.
- **VARIABLE-RATE STEEL MULTI-LEAF REAR SPRINGS** provide a smooth ride and minimize jounce.

AXLES

Three axle ratios are available for rear-wheel-drive Astro models:

- 3.42:1 for mid-range towing needs
 - 3.73:1 for maximum torque and towing capability.
- Three axle ratios are available for rear-wheel-drive Astro models:
- 3.23:1 for maximum fuel economy
 - 3.42:1 for mid-range towing needs
 - 3.73:1 for maximum torque and towing capability.

STEERING

- **UPDATED RECIRCULATING BALL-TYPE POWER STEERING SYSTEM** is standard equipment on all Astro models for 1999, replacing Electronic Variable Orifice (EVO) steering. The system offers a steering gear ratio change of 16/13:1 (14:1 with FE2 Suspension Package). Additional features are retained steering effort, road feedback and reduced steering gear noise.

BRAKES

- **POWER FRONT DISC REAR DRUM BRAKES** are standard on Astro.
- **LARGE (11.8" DIAMETER AWD; 11.0" RWD) VENTILATED FRONT ROTORS** provide excellent brake cooling.
- **AUDIBLE PAD-WEAR SENSORS** alert the driver when brake pad maintenance is needed.
- **GM'S ABS WITH ANTILOCK BRAKE SYSTEM** is standard equipment. Some things to keep in mind about antilock brakes:
 - ABS helps maintain steering control during severe braking situations by reducing wheel lockup on most slippery surfaces. All the driver has to do is maintain pressure on the brake pedal and steer the vehicle.
 - ABS adjusts brake pressure by modulating the brakes several times per second, a rate even most skilled professional drivers cannot attain physically.
 - The system modulates the brake-line pressure at the wheels. Drivers should not "pump" the brakes in emergency braking situations. Rather, they should maintain constant pressure on the brake pedal, allowing the system to work effectively.

1999 ASTRO SPECIFICATIONS

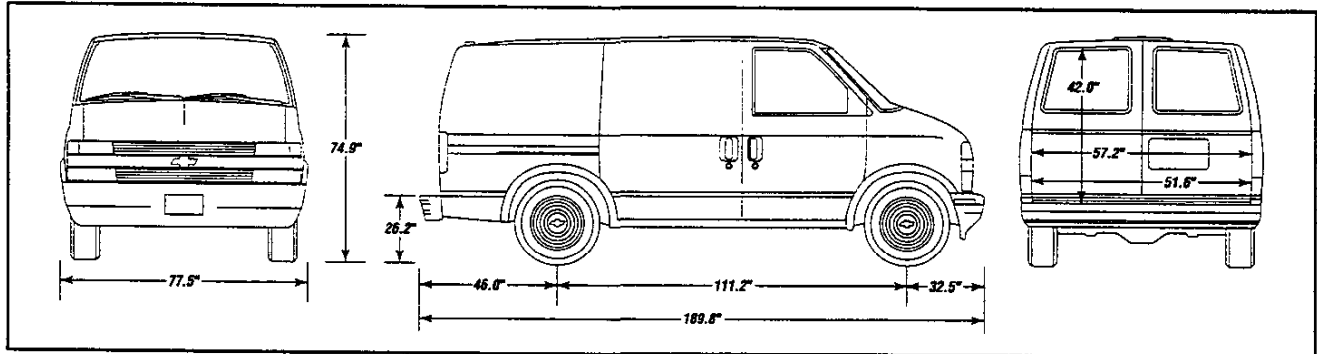
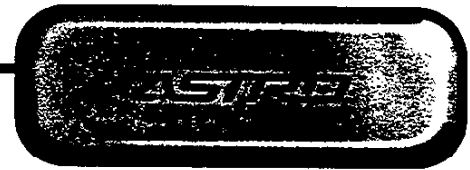

MODEL AVAILABILITY

Astro Van RWD/AWD	
Passengers	5-8 (Passenger Van), 2 (Cargo Van)
Class	Midsize Van
Assembly plant	Baltimore, Maryland
Primary structure	Unibody, Integral steel stub frame
Body material	Two-side galvanized steel (except roof)

SPECIFICATIONS & CAPACITIES

Exterior Dimensions	RWD		AWD	
	U. S. STANDARD	METRIC	U. S. STANDARD	METRIC
Wheelbase	111.2 in.	2825mm	111.2 in.	2825mm
Overall length	189.8 in.	4821mm	189.8 in.	4821mm
Overall height	74.9 in.	1903mm	74.9 in.	1903mm
Maximum width	77.5 in.	1968mm	77.5 in.	1969mm
Ground to rear load floor	26.0 in.	660mm	26.0 in.	660mm
Ground clearance front/rear	6.8/7.4 in.	173/188mm	6.8/7.4 in.	173/188mm
Interior Dimensions*				
Headroom (front/mid./rear)	39.2/37.9/38.7 in.	996/963/983mm	39.2/37.9/38.7 in.	996/963/983mm
Legroom (front/mid./rear)	41.6/36.5/38.5 in.	1057/927/978mm	41.6/36.5/38.5 in.	1057/927/978mm
Shoulder room (front/mid./rear)	64.0/67.1/67.1 in.	1626/1704/1704mm	64.0/67.1/67.1 in.	1626/1704/1704mm
Hip room (front/mid./rear)	64.9/50.9/57.1 in.	1649/1293/1450mm	64.9/50.9/57.1 in.	1649/1293/1450mm
Capacities				
Curb weight (min.) (lbs./kg)	4186 lbs.	1903 kg	4433 lbs.	2015 kg
Maximum GVWR (lbs./kg)	5950 lbs.	2699 kg	6100 lbs.	2767 kg
Base payload (std.) (lbs./kg)	1764 lbs.	801.1 kg	1667 lbs.	759 kg
Cargo capacity (cu. ft./liters)	170.4 cu. ft.	4838 liters	170.4 cu. ft.	4838.1 liters
Max. trailer capacity (lbs./kg)	5500 lbs.	249 kg	5000 lbs.	2268 kg
Fuel tank capacity (gal./liters)	25 gallons	94.6 liters	25 gallons	94.6 liters

*Front interior dimensions also apply for Astro Cargo Van models.

STEERING

Type	RWD	AWD
	Integral power	Integral power
Steering ratio	16/13:1*	16/13:1*
Turning diameter, curb-to-curb (ft./m)	38.3/13.0	41.7/12.9

*With FE2 Suspension the steering ratio is 14:1.

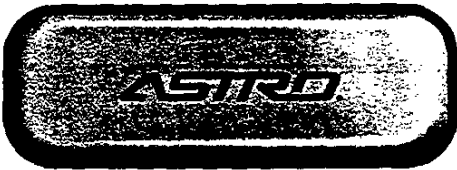

1999 CHEVROLET ASTRO



CHEVROLET INTERNATIONAL

Astro is sold in other countries besides the U.S. In many cases, changes are made in the vehicle's specifications to meet the unique demands of those markets and/or comply with local regulations. Additionally, these products sometimes fill a very different role in non-U.S. markets. If you need to know what the differences are, in specifications or marketing strategies, in any given country, please look in the Chevrolet International section of this publication to identify the right GM person to contact for that kind of information. Chevrolet Communications (U.S.) does not have those details.

AFFINITY RELATIONSHIPS

Because Chevrolet offers the most comprehensive lineup of cars and trucks of any automotive manufacturer, it goes without saying that there is a product for virtually everyone, whatever their needs. From the bass fisherman who needs a reliable truck to tow his fishing boat, to the soccer mom who needs a dependable van to get the team to the fields, Chevrolet can offer a vehicle to fit anyone's lifestyle.

With this in mind, Chevrolet has developed what has come to be known as "Affinity Marketing." By developing relationships with over eighty lifestyle organizations, sporting groups and spokespeople that represent the Chevrolet image of its cars and trucks and the people who drive them, Chevrolet is able to market its products and services by forming relationships and offering marketing support to groups like the United States Figure Skating Association, Ducks Unlimited and individuals who reflect the Chevrolet vision of excellence, like 1998 Olympic Gold Medalist Tara Lipinski and country music star George Strait.

Astro has affinity relationships with:

- Bass Pro Shops
- Barrier Breakers-Sarah Will
- Big Cedar Lodge
- Deer Valley Resort
- East Coast Fisherman
- Mad River Canoe
- Ranger Boats
- U.S. Ski Team
- Vail Associates.

For more information, call 1-800-CHEVY-MI.

GENUINE CUSTOMER CARE

Chevrolet owners are covered by Genuine Customer Care, a comprehensive owner protection plan that includes the following:

NEW VEHICLE LIMITED WARRANTY

This warranty is for GM vehicles in the United States. Owners should see their Chevrolet dealer for complete terms and conditions of this New Vehicle Limited Warranty. Items covered for 3 years or 36,000 miles* for manufacturer's defects include:

- The complete vehicle
- Tires
- Towing to the nearest Chevrolet dealership
- Sheet-metal coverage:
 - Corrosion coverage
 - Rust-through coverage†
- Repairs made to correct any vehicle defect
- No charge for most warranty repairs.

* Whichever comes first. †Six years or 100,000 miles, whichever comes first.

1999 ASTRO SPECIFICATIONS

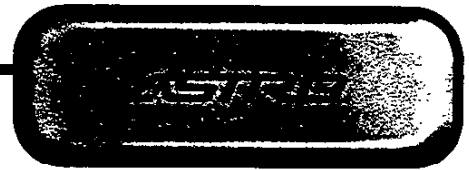

MILEAGE

Powertrain	4-Speed automatic w/Vortec 4300 V6*		4-Speed automatic w/Vortec 4300 V6 AWD **	
Mileage:	MPG	liters/100km	MPG	liters/100km
City	16	14.7	15	15.7
Highway	20	11.8	19	12.4
Combined	18	13.1	17	13.8
Est. cruising range:	mi.	km	mi.	km
City	400	644	375	603
Highway	500	804	475	764
Combined	450	724	425	684

*Based on 1999 information. **Based on 1999 information.

TRAILERING INFORMATION

	RWD	AWD
Trailer classification	Medium	Medium
Gross trailer weight (lbs/kg, up to)	5500/2495	5000/2268
Max tongue load (lbs./kg)	650/295	600/272

WHEELS & TIRES

Type*	RWD & AWD			
	Steel	Styled-steel	Chrome-cladded styled-steel	Brushed-aluminum
Size (in.)	15 x 6	15 x 6.5	15 x 6.5	15 x 6.5

* 15" x 6.5" Steel Wheels standard with base-level models; 15" x 6.5" Styled-Steel Wheels standard on Astro LS; 15" x 6.5" brushed-aluminum wheels standard on Astro LT. All uplevel wheels are optional on base-level model.

Tire type	All-season steel-belted radial blackwall
Tire size	P215/75 R-15
Optional tire	P215/75 R-15 white-outline lettered or P235/65R-15 white-outline lettered touring (w/FE2 Touring Suspension Package)

All specifications are preliminary and subject to change. Chevrolet Motor Division. June, 1998.



1999 ASTRO FEATURE AVAILABILITY



	Standard	LS	LT	Cargo Van
INTERIOR				
Next Generation Air Bags - Dual	S	S	S	S
Air Conditioning - Front, With CFC-Free Refrigerant	S	S	S	S
- Front and Rear	O	O	O	NA
Convenience Group - Tilt-Wheel™ & Speed Control	O	S	S	O
- Power Door Locks & Power Windows	O	S	S	O
Door Beams - Side Impact	S	S	S	S
Door Trim - Driver and Passenger, color-keyed cloth/carpet	S	S	S	NA
Gauges - Fuel level, Odometer, Oil Pressure, Speedometer, Temperature Gauge, Trip Odometer, Voltmeter	S	S	S	S
Lights, Interior - Delayed entry	S	S	S	S
Locks - Power Door O	S	S	O	
Passlock® Theft-Deterrent System	S	S	S	S
Scotchgard™ Protection	S	S	S	O
Seating - 5-Passenger	S	NA	NA	NA
- 8-Passenger	O	S	S	NA
- 7-Passenger	O	O	O	NA
- 2-Passenger	NA	NA	NA	S
Seats - Vinyl Front Reclining Buckets & Center Bench	S	NA	NA	NA
- Cloth Front Reclining Buckets & Two Bench	O	S	NA	NA
- Cloth Front and Center Reclining Buckets & Rear Bench	O	O	NA	NA
- Special Cloth Front Reclining Buckets & Two Split-Bench	NA	NA	S	NA
- Special Leather Front Reclining Buckets & Two Split-Bench	NA	NA	O	NA
- Special Cloth or Leather Front & Center Reclining Buckets & Rear Split-Bench	NA	NA	O	NA
- Vinyl Front Reclining Buckets	NA	NA	NA	S
Seat Package - Armrests, Map Pocket, Lumbar Support	O ¹	S	S	O ¹
Steering Wheel - Black Four-Spoke	S	S	NA	S
- Black Leather Wrapped	NA	O	S	NA
Stereo - ETR AM/FM with Digital Clock	S	S	S	S
- ETR AM/FM with Cassette Player	O	O	O	O
- ETR AM/FM with Compact Disc Player	O	O	O	O
- ETR AM/FM with Cassette And Compact Disc Players	O	O	O	O
- Rear Seat Radio Controls and Jacks	NA	O	O	NA
Storage Compartment - Left Rear Quarter, Third Seat Area	S	S	S	NA
Sunshades - Cloth w/Map Bands, Extenders	S	NA	NA	NS
- Cloth w/Lighted Mirrors, Extenders	O	S	S	NA
- Vinyl Color-Keyed w/Map Bands	NA	NA	NA	S
Warning Tone - Headlamps-On Warning Buzzer	S	S	S	S
Windows - Swing-Out on Sliding Door, LH Quarter Panel	S	S	S	O
Windows - Swing-Out on Rear Door	NA	S	S	O
Wipers - Intermittent Variable	S	S	S	S
EXTERIOR				
Daytime Running Lamps (DRL)	S	S	S	S
Doors - Sliding RH Side, RH and LH Rear Loading	S	S	S	S
Doors - Rear Dutch w/Liftglass	O ²	O	O	O
Mirrors - Below Eyeline Foldaway, Black	S	NA	NA	S
- Below Eyeline Electric Remote Control, Black	O	S	S	NA
Tires - P215/75R-15 All-Season Blackwall	S	S	S	S
- P215/75R-15 All-Season White Lettered	O	O	O	O
Wheels - Steel 15" x 6" Silver Painted w/Black Center Cap	S	NA	NA	S
- Styled-Steel 15" x 6" Silver Painted	O	O	NA	O
- Styled-Steel 15" x 6" Chrome-Cladded	O	S	O	O
- Brushed Aluminum 15" x 6"	NA	O	S	NA
FUNCTIONAL				
Brakes - 4-Wheel Anti-Lock (ABS) & Power Front Disc/Rear Drum	S	S	S	S
Cargo Capacity - Up To 170.4 cu. ft. ³	S	S	S	S
Engine - Vortec 4300 V6 SFI	S	S	S	S
Fuel Capacity - 25-Gallon	S	S	S	S
Remote Keyless Entry	O ²	O	S	O ²
Suspension - Touring ⁴	O	O	O	NA
Trailer Special Equipment - up to 5500 lbs.	O	O	O	O
Transmission - 4-Speed Electronically Controlled Automatic	S	S	S	S

S — Standard. O — Optional (some options may be available only as part of a Preferred Equipment Group (PEG)). NA — Not available. 1 Available with cloth trim only. 2 Requires optional power door locks. 3 Cargo Van model and Passenger Van model when center- and rear-row seats are removed. 4 Available on rear-wheel drive model only; not available on All-Wheel-Drive model; requires brushed-aluminum wheels.

Astro Passenger Van

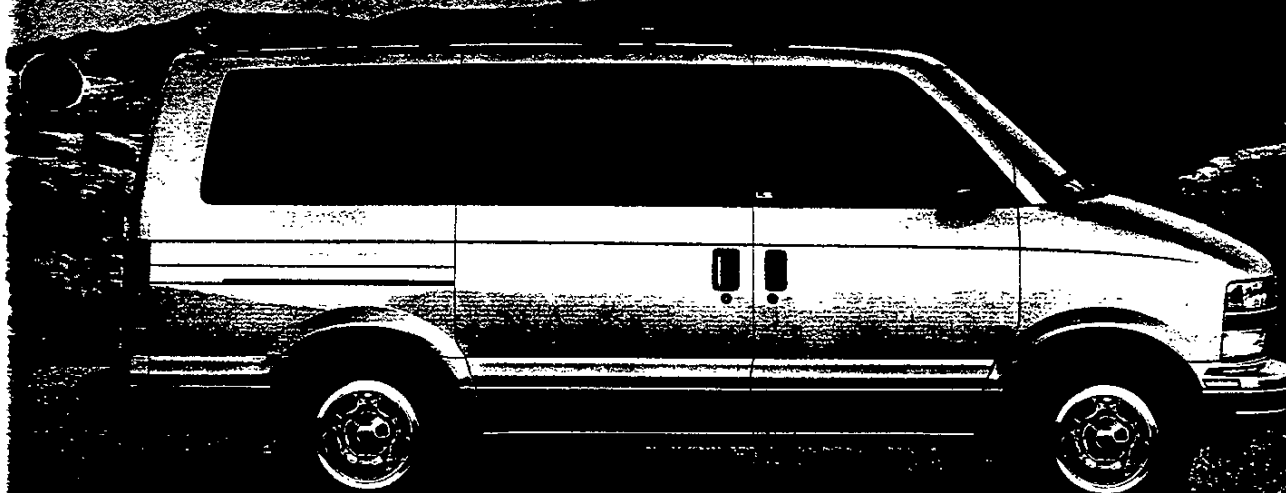

Astro Passenger Van

Focus

Astro LS Passenger Van with available rear Dutch doors and Preferred Equipment Group (PEG) 1SC
(image above)

The Focus vehicle for 1999 is Astro LS Passenger Van with available rear Dutch doors and PEG 1SC. Astro is the most versatile midsize van, providing "minivan" utility and the toughness of a truck. Astro LS represents the best opportunity for high volume Astro Passenger Van sales at your dealership.

Ordering recommendations:

Recommended Astro Passenger Van content, based on anticipated national sales volume, is listed below to assist your dealership in ordering.

LS Decor special features include:

- Chrome-Cladded Styled-Steel Wheels
- Convenience Group (includes Tilt-Wheel™ Steering Column and electronic speed control)
- Eight-Passenger Seating
- Electric Remote Mirrors
- Power Door Locks and Power Windows
- Overhead Console with Electronic Compass, Outside Temperature Display and Trip Computer.

Popular colors: Ivory White, Dark Forest Green Metallic, Medium Bronzemist Metallic and Medium Cadet Blue Metallic.

Astro Passenger Van Owners ... a Closer Look

With the versatility of a minivan and the added roominess and toughness of a truck, Astro Passenger Van appeals to a broad customer base of owners from 25 to 55 years of age. Family-centered customers who enjoy do-it-yourself projects and outdoor activities find Astro Passenger Van an appealing vehicle choice.

About Dealer Order Guide inserts

The Dealer Order Guide inserts are your first look at Chevy Truck models for 1999. This information is preliminary and is subject to change. Use these inserts to assist in ordering your initial shipments. Most of your volume should come from the Focus vehicle, which is the model chosen for its saleability. It is equipped with the product features that customers want most. (Model, PEG and optional equipment vary by region.) Refer to the Retail Sales Analysis (RSA) to verify or select your dealership's Focus vehicle content. There is also the Feature vehicle, which is the "image" model Chevrolet will profile most in its advertising. This vehicle is meant to capture attention and create consumer awareness.

Feature

Astro LT All-Wheel-Drive Passenger Van with available rear Dutch doors and PEG 1SE
(image below)



The 1999 Feature vehicle is the Astro LT All-Wheel-Drive Passenger Van with leather seating surfaces, available rear Dutch doors and PEG 1SE.

LT Decor All-Wheel-Drive with PEG 1SE includes:

- Remote Keyless Entry, Power Windows and Power Door Locks
- Convenience Group (includes Tilt-Wheel™ Steering Column and electronic speed control)
- Exterior Electric Remote Mirrors
- Eight-Passenger Seating with 6-Way Power Driver Seat
- Overhead Console with Electronic Compass, Outside Temperature Display and Trip Computer
- Brushed-Aluminum Wheels
- Luggage Carrier, Black
- Leather-Wrapped Steering Wheel
- Cargo Convenience Net.



1999 ASTRO SPECIFICATIONS



BRAKES

	RWD	AWD
Type	Hydraulic power front disc/rear drum 4-wheel ABS	
Front size (disc) (in./mm)	11.86 x 1.04/301 x 26	11.57 x 1.25/294 x 32
Rear size (drum) (in./mm)	9.5 x 2.0/241 x 51	9.5 x 2.0/241x 51
Booster diaphragm	Hydro-boost	Hydro-boost
Parking brake	Cable to rear wheels	Cable to rear wheels

ENGINES

	L35
Type	Vortec 4300 V6 SFI
Block material	Cast-iron
Cylinder head material	Cast-iron
Bore & stroke (in./mm)	4.00 x 3.48/101.6 x 88.4
Displacement (cu. in./cc)	262/4300
Compression ratio	9.2:1
Induction system	SFI
Valves/cylinder	2
Lifters	Hydraulic roller
Cam drive	Chain
Horsepower/Kw @ rpm (SAE net)	190 @ 4400/142 Kw @ 4400
Torque/N-m @ rpm (SAE net)	250 @ 2800/339 N-m @ 2800
Redline (rpm)	5600
Recommended fuel (min.)	87 Octane

TRANSMISSIONS

	RWD & AWD
Model availability	RWD & AWD
Transmission type	4-Speed electronically-controlled automatic w/overdrive & torque converter
1st	3.06
2nd	1.63
3rd	1.00
4th	0.70
Reverse	2.29

CHASSIS

	RWD	AWD
Frame	Integral/unibody; partial ladder-Type frame incorp. w/floor panels	Integral/unibody; partial ladder-Type frame incorp. w/floor panels
Front	Independent w/coil springs	Independent w/torsion bars
Rear	Variable-rate steel Multi-leaf springs	Variable-rate steel Multi-leaf springs
Shocks, front/rear (mm)	32/32	32/32
Anti-roll bar, front (mm)	32*	30
Rear axle	Semi-floating	Semi-floating

*RWD Astro Cargo Van front anti-roll bar is 28mm.

Astro Passenger Van

P.D.S.E.I. (New-for-'99 features appear in green.)

P.D.S.E.I. is a term used to help organize and explain key features and benefits in five major categories a customer needs and wants. Overall improvements, changes and deletions are highlighted. Please review the supplied information, keeping in mind that this material is provided to you before production start-up — and may change.



Astro Passenger Van



PERFORMANCE

• **ACTIVE TRANSFER CASE** (AWD models) — offers state-of-the-art All-Wheel-Drive technology in place of the current All-Wheel-Drive system. • **AUTOMATIC TRANSMISSION ENHANCEMENTS** — Vamac pump cover seals make possible better sealing. New clutch plate material is used, which is designed for improved durability and performance. • **RELIABLE RECIRCULATING BALL-TYPE POWER STEERING** — for excellent road feel. • **ALL-WHEEL-DRIVE MODELS** — the vehicle will normally operate in 2WD until the system senses rear wheel slip, at which time it will transfer torque to the front axle. • **STANDARD VORTEC 4300 V6 ENGINE WITH SEQUENTIAL FUEL INJECTION (SFI)** — provides smooth, quiet power and the biggest engine in its class.*



DURABILITY

• **NEW STARTER MOTOR** — designed for enhanced quality, dependability and reliability. • **PLATINUM-TIP SPARK PLUGS** — help Vortec engines travel up to 100,000 miles before their first scheduled maintenance.* • **EXTENDED-LIFE ENGINE COOLANT** — has a first scheduled replacement interval of 5 years or 150,000 miles, whichever comes first.† • **BUMPER TO BUMPER WARRANTY** — a 3-year/36,000-mile, no deductible, limited warranty, 24-Hour Roadside Assistance via a toll-free hot line and Courtesy Transportation,** if vehicle ever needs warranty work.



SAFETY

• **AVAILABLE OnStar** (dealer-installed) — uses Global Positioning System satellite technology to give drivers greater security and convenience. • **NEXT GENERATION DRIVER AND FRONT-PASSENGER AIR BAGS™** — designed to help protect against injury in certain moderate to severe frontal collisions. • **4-WHEEL ANTI-LOCK BRAKE SYSTEM (ABS)** — standard on all models, reduces wheel lockup while braking hard on most slippery surfaces.



EXTERIOR

• **AVAILABLE RUNNING BOARDS** (optional on all models with body cladding) — make entry and exit easy (dealer-installed). • **TWO NEW EXTERIOR COLORS** — Medium Charcoal Gray Metallic and Medium Bronzemist Metallic. • **THREE NEW STRIPE COLORS AND NEW STRIPE DESIGN FOR LT TRIM** — Silvermist, Gold and Bronzemist. • **BASECOAT/CLEARCOAT PAINT** — not only provides a durable, lustrous finish, but also reduces the severity of water-spotting and etching from acid rain. • **TWO-SIDE GALVANIZED STEEL** — on major exterior body panels (except roof), makes additional rustproofing unnecessary. • **LOWER BODY CLADDING** (standard with LS and LT trim levels, available with Base Decor with running boards) — adds a handsome styling touch.



INTERIOR

• **AVAILABLE ROOF CONSOLE WITH ELECTRONICS AND TRIP COMPUTER** (standard with LS and LT Decor) — includes electronic compass, outside temperature display and average and instantaneous fuel economy, trip range, fuel used and elapsed time. • **AVAILABLE ROOF CONSOLE WITHOUT ELECTRONICS** (Base Decor only) — provides convenient overhead storage. • **SEATING FOR EIGHT** — standard with LS and LT trim levels, optional with Base trim (which includes standard seating for five). • **SCOTCHGARD™ PROTECTOR** — on cloth seats, door trim panels and floor carpet. Resists stains for easy cleanup. • **UP TO 170.4 CU. FT. OF CARGO SPACE** — with center- and rear-row seats removed. That's enough room to close the rear doors while carrying 4' x 8' sheets of plywood.

*Excludes other GM vehicles. †Maintenance needs vary with different uses and driving conditions. See owner's manual for details. **At participating dealerships. ††Always use safety belts and proper child restraints, even with Next Generation air bags. See owner's manual for more safety information.

1999 ASTRO PASSENGER HIGHLIGHTS

NEW FOR 1999

EXTERIOR

- **New available running boards
(dealer installed)**
- **New LT stripe design**

INTERIOR

- **New roof console with convenient storage only
(optional on base models)**
- **New roof console with trip computer, compass and temp gage
(standard on LS & LT models)**

TWO NEW EXTERIOR COLORS

- **Medium Bronzemist Metallic**
- **Medium Charcoal Gray Metallic**

THREE NEW LT STRIPE COLORS

- **Silvermist**
- **Autumwood**
- **Bronzemist**

POWERTRAIN

- **New active transfer case on ALL-WHEEL-DRIVE models**

Trim Colors



Custom Vinyl available in Medium Gray, Blue, Neutral and Red.*



Custom Cloth (LS models) available in Medium Gray, Blue, Neutral and Red.



Special Cloth (LT models) available in Medium Gray and Neutral.

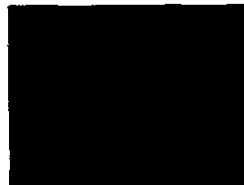

Special Leather (optional on LT models) available in Medium Gray and Neutral.

*Not available on Base models with standard 5-passenger seating.

Seat Styles

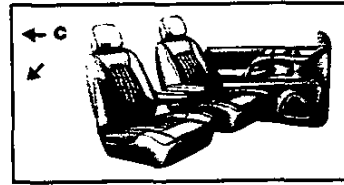
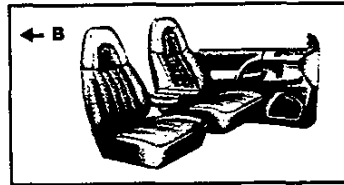
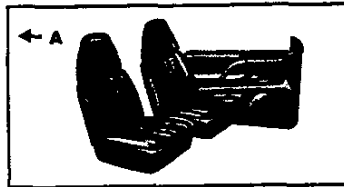

- A. Custom Vinyl front high-back reclining bucket seats with adjustable 3-passenger center-row bench seat — standard on Base model.
- B. Custom Cloth front high-back reclining adjustable bucket seats with folding integral armrests. Adjustable 3-passenger center- and rear-row bench seats — standard on LS, available on Base model.
- C. Special front high-back bucket seats with Special Cloth or optional Special Leather with folding armrests and adjustable head restraints. Split-folding center- and rear-row reclining bench seats with fold-down center console, convenience tray and cup holders — standard on LT.

Wheels

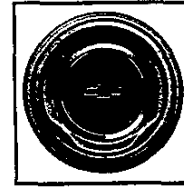

15" x 6" standard argon-painted steel wheel with bright and black hubcap.

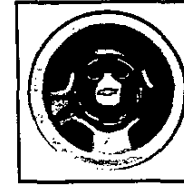

(RPO PA6) 15" x 6.5" styled-steel, painted (optional on Base).

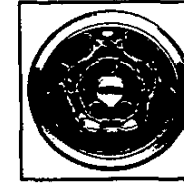

(RPO PC2) 15" x 6.5" chrome-cladded styled-steel (standard on LS, optional on Base and LT).

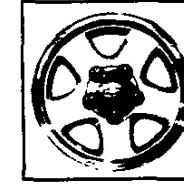

(RPO PF3) 15" x 6.5" new brushed-aluminum (optional on Base, LS, standard on LT).

Most Popular Exterior Colors with Corresponding Interior Color Availability

Interior Material Colors	Medium			
	Gray	Blue	Neutral	Red
Exterior Colors				
Ivory White	✓	✓	✓	✓
Dark Forest Green Metallic	✓		✓	
Medium Bronzermist Metallic	✓		✓	
Medium Cadet Blue Metallic	✓	✓	✓	

See order guide for color availability by model.

Most Popular Exterior Colors by Percentage

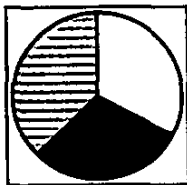

Clockwise, at left, are the four colors anticipated to be the most popular Astro Passenger Van choices for 1999, based on national sales volume. They are listed for reference only. To identify the top-selling colors in your area by model, use the Retail Sales Analysis (RSA).

Ivory White (#10)	33%
Dark Forest Green Metallic (#57)	13%
Medium Bronzermist Metallic (#76)	9%
Medium Cadet Blue Metallic (#25)	8%
Other colors	37%

NOTE: New Astro Passenger Van exterior colors are Medium Charcoal Gray Metallic (#14) and Medium Bronzermist Metallic (#76). Dark Purple Metallic (#05) and Cherry Ice Metallic (#59) have been cancelled.

Alternate Seating Packages

ZP7 7-passenger seating includes:
4 high-back reclining bucket seats
3-passenger adjustable rear-row seat.

ZP8 8-passenger seating* includes:
2 high-back reclining bucket seats
2 3-passenger adjustable seats.

*Standard with LS and LT Decors.

ASTRO PASSENGER VAN

STANDARD EQUIPMENT SUMMARY

		<u>BASE</u>	<u>LS</u>	<u>LT</u>
<u>CHASSIS</u>				
ALTERNATOR:	100 AMP	S	S	S
BRAKES:	4-WHEEL ANTILOCK POWER FRONT DISC/REAR DRUM	S	S	S
ENGINE:	VORTEC 4300 V6 SFI (INCLS ENGINE OIL COOLER, HD RADIATOR AND TRANS OIL COOLER)	S	S	S
FUEL CAPACITY:	25 GALLON	S	S	S
STEERING:	VARIABLE POWER ASSIST	S	S	S
TRANSMISSION:	4-SPEED AUTOMATIC W/OVERDRIVE	S	S	S
<u>INTERIOR</u>				
AIR BAGS:	DRIVER AND FRONT PASSENGER (NEXT GENERATION)	S	S	S
AIR CONDITIONING:	FRONT	S	S	S
CARGO CONVENIENCE	NET	-	S	S
CONSOLE:	OVERHEAD (INCLS COMPASS, OUTSIDE TEMPERATURE & TRIP)	-	-	S
CONVENIENCE GROUP:	TILT WHEEL AND SPEED CONTROL	-	S	S
	POWER DOOR LOCKS & WINDOWS	-	S	S
DOOR BEAMS:	DRIVER, PASSENGER AND SLIDING SIDE DOOR	S	S	S
DOOR LOCKS:	CHILD SAFETY LOCK	S	S	S
FABRIC PROTECTOR:	SCOTCHGARD - ON FLOOR CARPETING AND OPTIONAL CLOTH TRIMS	S	S	S
FLOOR COVERING:	COLOR-KEYED CARPETING ON WHEEL HOUSING AND ENTIRE LOAD FLOOR	S	S	S
	COLOR-KEYED FLOOR MATS FOR ALL SEATING AREAS	-	S	S
GAUGES:	COOLANT TEMPERATURE, FUEL LEVEL, ODOMETER, OIL PRESSURE, SPEEDOMETER, TRIP ODOMETER AND VOLTMETER	S	S	S
GLASS:	TINTED; SOLAR-RAY ALL WINDOWS, COMPLETE BODY GLASS	S	-	-
	DEEP TINTED; SOLAR-RAY ALL WINDOWS, COMPLETE BODY GLASS	-	S	S
LIGHTING:	STEPWELL, STORAGE COMPARTMENT, THREE DOME WITH FRONT, REAR AND SLIDING DOOR ACTUATED SWITCHES. DOME DEFEAT SWITCH	S	-	-
	STEPWELL, STORAGE COMPARTMENT, FRONT & MIDDLE ENTRY INCLUDE ADJUSTABLE READING, REAR DOME AND DOME DEFEAT SWITCH	-	S	S
	DELAYED ILLUMINATED ENTRY LAMPS	S	S	S
LOCKS:	SINGLE TWO-SIDED KEY (Includes Brand Logo)	S	S	S
	KEYLESS REMOTE	-	-	S
SECURITY:	PASSLOCK THEFT DETERRENT SYSTEM	S	S	S
POWER POINTS:	TWO FRONT, ONE LH REAR (IN ADDITION TO CIGARETTE LIGHTER)	S	S	S
RADIO:	ELECTRONICALLY TUNED AM/FM STEREO W/SEEK-SCAN AND DIGITAL CLOCK	S	S	S
SEATS:	8-PASSENGER SEATING ARRANGEMENT	S	S	S
	FRONT HIGH BACK RECLINING ADJUSTABLE BUCKETS WITH ALL VINYL TRIM, NO ARMRESTS, INCLUDES CENTER REMOVABLE, ADJUSTABLE 3-PASSENGER BENCH SEAT WITH HEAD RESTRAINTS	S	-	-

Competitive Models

- Ford Windstar
- Mercury Villager
- Mazda MPV
- Dodge Caravan/Plymouth Voyager
- Nissan Quest
- Toyota Sienna

New for 1999

- A new state-of-the-art active transfer case replaces the current All-Wheel-Drive system. The vehicle will normally operate in 2WD until the system senses rear wheel slip, at which time it will transfer torque to the front axle. The system consists of a new transfer case assembly, control module and electrical harnesses.
- Transmission enhancements include a revised check ball pocket designed to reduce uneven load characteristics and minimize wear. Vamac pump cover seals replace the current polyacrylic material for improved overall sealing. New clutch plate material is formulated to improve durability and performance.
- An available roof console with trip computer, standard on LS or LT trim, is a highly functional addition to Astro Passenger Van for 1999. In addition to the usual console features like a compass and outside temperature readout, the new trip computer displays average fuel economy, instantaneous fuel economy, trip range, fuel used and elapsed time. A roof console with convenient storage and four adjustable lights is available on Base models.
- OnStar, a dealer-installed option, is available for 1999. It uses Global Positioning System satellite technology to bring drivers enhanced safety and convenience.
- Available dealer-installed running boards (on Astro models with body cladding) contributes to Astro's styling and utility for '99.

Forecasted Percent of Mix

SERIES	
RWD	75%
AWD	25%
Total	100%
TRIM LEVELS	
Base	38%
LS	47%
LT	15%
Total	100%
ENGINES	
Vortec 4300 V6 SFI	100%
Total	100%
TRANSMISSIONS	
4-Speed Electronically Controlled Automatic with Overdrive	100%
Total	100%

Deletions

- Two exterior colors have been deleted for 1999: Dark Purple Metallic and Cherry Ice Metallic and have been replaced by two new colors: Medium Charcoal Gray Metallic and Medium Bronzermist Metallic.
- Electronic Variable Orifice (EVO) feature has been deleted from integral variable-assist power steering.

Other Information on Significant Features

- Chevy Astro Passenger Van boasts the Vortec 4300 V6 SFI engine for smooth idle and near-instantaneous hot starts. Strong torque, high power output and smooth operation make the Vortec V6 engine an outstanding performer.

ASTRO PASSENGER VAN

MODEL AND BODY

Description	Model No.	Body	Wheelbase
Rear-Wheel Drive Model			
Astro Van	CM11006	ZW9	111.2"

Description	Model No.	Body	Wheelbase
All-Wheel Drive Model			
Astro Van	CL11006	ZW9	111.2"

GVWR SELECTOR (MUST SPECIFY)

GVW RATING (LBS.)	Minimum Equipment Required for GVW Rating		
	(a) GAWR (LBS.)		Restrictions
	Front	Rear	
C6M	5950	2800 3150	CM11006 Only
C5M	6100	3050 3150	CL11006 Only

(a) GAWR's shown are the minimum for each axle with equipment listed. Other GAWR's are available and they are determined as the minimum capacity of either axle or springs or tires.

CAPACITIES

CM11006		CL11006	
SPRINGS:	AXLES:	SPRINGS:	AXLES:
FRONT	FRONT	FRONT	FRONT
2800 Base	2800 Base	3050 Base	3050 Base
REAR	REAR	REAR	REAR
3150 Base	3150 Base	3150 Base	3150 Base

POWER TEAMS (Must Specify Engine, Transmission and Rear Axle)

(Consult GVWR Selector for Minimum Equipment Required)

ENGINE	TRANSMISSION	AXLES			GVWR
	(Auto)	3.23	3.42	3.73	
CM11006					
L35 Vortec 4300 SFI V6	M30	GU5	GU6	GT4	5950
CL11006					
L35 Vortec 4300 SFI V6	M30	—	GU6	GT4	6100

ASTRO PASSENGER VAN

ADDITIONAL OPTIONS

	ACKNOWLEDGMENTS:
R8S	Multiple Order Numbers
R8T	Preliminary Invoice
C69	AIR CONDITIONING: Front and Rear (105 Amp Alternator) AXLE, REAR: (MUST SPECIFY)
GU5	3.23 Ratio (CM11006 Only)
GU6	3.42 Ratio
GT4	3.73 Ratio
G80	Locking Differential
	BODY CODE:
ZW9	Standard Body Equipment
E54	Dutch Doors (Incls Wiper/Washer)(Reqs AU3 Power Door Locks w/Base Decor) w/LS or LT Decor w/Base Decor
AP9	CARGO NET: (Incl w/LS and LT Decor)(Avail w/Base Decor)
V54	CARRIER, LUGGAGE: Painted Black (Incl w/LS or LT Decor)
V10	COLD CLIMATE PACKAGE: (Incls Engine Block Heater and Coolant Protection)
	CONSOLE, ROOF:
DK6	Without electronics (Available w/Base Decor)
DK8	With electronics (Available w/Base Decor) (Included w/LS and LT Decor)
	CONVENIENCE GROUP: (Included w/LS & LT Decor)(Avail w/Base Decor)
ZQ2	Power Windows and Power Door Locks
ZQ3	Tilt Wheel and Speed Control (Incl w/LS & LT Decor) (Avail w/Base Decor)
C49	DEFOGGER: Rear Window Electric (Reqs E54 Body)
AU3	DOOR LOCK SYSTEM, POWER: (Incl w/LS & LT Decor) (Available w/Base Decor)
	EMISSIONS: (MUST SPECIFY) (Refer Emission Requirements Tab Section)
FE9	Federal Emission Requirements
NG1	Connecticut, District of Columbia, Delaware, Massachusetts, Maryland, New Hampshire, New Jersey, New York, Pennsylvania, Rhode Island or Virginia Emission Requirements w/C5M w/o C5M
YF5	California Emission Requirements
NB8	CA, CT, DC, DE, MA, MD, NH, NJ, NY, PA, RI or VA Emission Override (Reqs FE9 Emissions)
NC7	Federal Emission Override (Reqs YF5 or NG1 Emissions)
B37	FLOOR MATS: Front and Rear, Color-Keyed (Included w/LS and LT Decor)(Avail w/Base Decor) w/ZP7 or ZP8
AJ1	GLASS, DEEP TINTED: Solar-Ray (Incl w/LS & LT Decor) (Avail w/Base Decor)
TL1	GRILLE: Uplevel Grille and Composite Headlamps (Reqs Base Decor) GVWR RATINGS: (MUST SPECIFY)
C6M	5950 Lbs. (CM11006 Only)
C5M	6100 Lbs. (CL11006 Only)
C36	HEATER: Rear
C95	LAMPS, READING: (Avail w/Base Decor without DK6/DK8)
AU0	LOCK: Keyless Remote (Incl w/LS and LT Decor) (Reqs AU3 Power Door Locks w/Base Decor)
D48	MIRRORS: Below-Eye-Line Exterior, Electric Remote, Black (Incl w/LS & LT Decor) (Requires ZQ2 Power Windows and Power Door Locks w/Base Decor)
B74	MOLDING: Body-Side (Avail w/Base Decor Only) (N/A w/BVE Running Boards) PAINTS, EXTERIOR: (Refer Color/Trim Chart)
ZY1	Solid
ZY2	Two-Tone Appearance (w/Base Decor Reqs BVE Running Boards)

ASTRO PASSENGER VAN

ADDITIONAL OPTIONS

- RADIO EQUIPMENT: (Electronically Tuned AM/FM Stereo Radio w/Seek-Scan and Digital Clock) Standard**
- UM6 Electronically Tuned AM/FM Stereo Radio w/Seek-Scan, Digital Clock and Cassette Tape
- UL0 Electronically Tuned AM/FM Stereo Radio w/Seek-Scan, Digital Clock, Automatic Tone Control, Cassette Tape, Theft Lock and Speed Compensated Volume (N/A w/Base Decor)
- UN0 Electronically Tuned AM/FM Stereo Radio w/Seek-Scan, Digital Clock, Automatic Tone Control, Compact Disc Player, Theft Lock and Speed Compensated Volume (N/A w/Base Decor)
- UP0 Electronically Tuned AM/FM Stereo Radio w/Seek-Scan, Digital Clock, Automatic Tone Control, Stereo Cassette Tape w/Search and Repeat, Compact Disc Player, Theft Lock and Speed Compensated Volume (N/A w/Base Decor)
- UK6 Rear Seat Radio Controls and Jacks (Reqs UL0/UP0 Radio) (N/A w/Base Decor)
- BVE **RUNNING BOARDS: (Includes Cladding)(N/A w/B74 Moldings) (Interim Availability)**
- SEATING ARRANGEMENTS: Adjustable**
- ZP7 7-Person Seating, 4 High Back Bucket Seats (Incls Seat Back Recliner) and 3-Passenger Bench (Incls AN0 Seat Pkg) (N/A Vinyl Trim)
- w/LT
- w/LS
- w/Base Decor
- ZP8 8-Person Seating, 2 Front High Back Reclining Bucket Seats and Two 3-Passenger Bench Seats (Incl w/LS or LT Decor) (Avail w/Base Decor)
- w/Base Decor
- SEAT, POWER:**
- AG1 6-Way, Driver's (Included w/LT Decor) (Available w/LS)
- (N/A w/Base Decor)
- AG2 6-Way, Passenger (Reqs AG1 6-Way Power Driver's Seat) (Deletes Front Underseat Storage Compartment)
- AN0 **SEAT PACKAGE: (Incls Inboard/Outboard Armrests, Map Pocket, Manually Adjustable Lumbar Support) (N/A Vinyl Trim) (Incl w/LS and LT Decor) (Incl w/ZP7 Seating w/Cloth Trim) (Avail w/Base Decor)**
- w/Base Decor
- w/LS & LT w/ZP7 Seating
- NP5 **STEERING WHEEL: Black Leather Wrapped (Incl w/LT Decor) (Avail w/LS Decor)**
- TIRES: (MUST SPECIFY) All Season Steel Belted Radial (Incls Front, Rear and Compact Spare (B/W=Blackwall, WOL=White Outlined Lettered)**
- QCU P215/75R-15 B/W
- QCM P215/75R-15 WOL
- Z82 **TRAILERING, SPECIAL EQUIPMENT: Heavy-Duty (Incls Platform Trailer Hitch and 8-Lead Wiring Harness)**
- UG1 **TRANSMITTER, HOMELINK® 3-CHANNEL GARAGE DOOR: (Reqs DK8)**
- WHEELS:**
- PF3 Aluminum, Brushed (Incl w/LT Decor)
- w/LS Decor
- w/Base Decor
- PC2 Styled, Steel, Chrome Cladded (Incl w/LS Decor)
- w/Base Decor
- PA6 Styled, Steel, Painted Silver (Reqs Base Decor)

ASTRO PASSENGER VAN

AVAILABLE WINDOW/DOOR ARRANGEMENTS (See Option Section for Restrictions)

STANDARD (Includes RH and LH Rear Quarter Windows)

STANDARD (W/ZW9)



OPTIONAL (W/E54 DUTCH DOORS)



AVAILABLE SEATING ARRANGEMENTS

(One Seating Arrangement Option Must Be Specified)
(See Interior and Exterior Chart for Restrictions)

w/ZP7

7-Person Seating

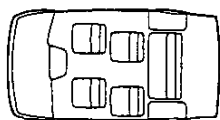

w/Base or LS Decor
Incls 4 High Back Reclining Buckets
(2 Front & 2 Mid-Ship) and
a 3-Passenger Adjustable
Bench Seat

w/LT Decor

Incls 4 Reclining Bucket Seats
(2 Front & 2 Mid-Ship) and a
Split Back Reclining 3-Passenger
Adjustable Seat w/Folding Armrests

w/ZP8

8-Person Seating
(Standard)

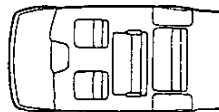

w/Base or LS Decor
Incls 2 High Back
Reclining Buckets
& Two 3-Passenger
Adjustable Bench Seats

w/LT Decor

Incls 2 Reclining Bucket
Seats & 2 Split Back
Reclining 3-Passenger
Adjustable Bench Seats

ASTRO PASSENGER VAN

**PAINT APPLICATION
ZY2 TWO-TONE APPEARANCE
(LOWER COLOR IS CLADDING)**

TWO-TONE APPEARANCE - ZY2

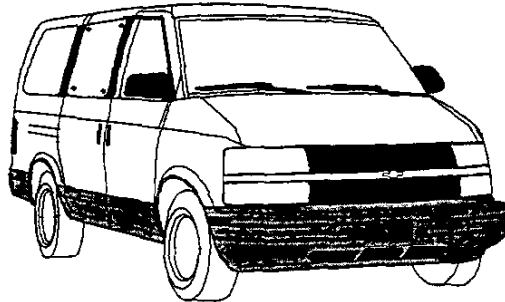

ASTRO PASSENGER VAN

INTERIOR AND EXTERIOR COLOR AVAILABILITY CHART

PLEASE NOTE: Below are the interior trim color and exterior paint combinations *recommended* by Chevrolet. They are the only available interior and exterior combinations allowed

BASE DECOR WITH ZY1 PAINT (WITHOUT CLADDING) (N/A BVE RUNNING BOARDS)

TRIM LEVEL		SEAT OPT	INTERIOR COLORS			
(Must Specify Seat Option and Interior Color)			Med Gray	Blue	Neutral	Red
N.C. Custom Vinyl High Back Reclining Bucket Seats		AV5	92W	26W	52W	79W
N.C. Custom Cloth High Back Reclining Bucket Seats		AV5	92G	26G	52G	79G
EXTERIOR COLORS		Color Code 1	Paint Scheme	Interior & Exterior Combinations Shown are the only Combinations Available		
AUTUMNWOOD, LT (Met)	55U	ZY1			X	
BLUE, MED CADET (Met)	25U	ZY1	X	X	X	
BLUE, TEAL (Met)	36U	ZY1	X		X	
BRONZEMIST, MED. (Met)	76U	ZY1	X		X	
COPPER, DK (Met)	69U	ZY1	X		X	
GRAY, MED. CHARCOAL (Met)	14U	ZY1	X	X	X	
GREEN, DK FOREST (Met)	57U	ZY1	X		X	
RED, LT CARMINE (Met)	53U	ZY1	X		X	
SILVERMIST (Met)	17U	ZY1	X	X		X
WHITE, IVORY	10U	ZY1	X	X	X	X

BASE & LS DECOR WITH ZY1 PAINT (INCLUDES CLADDING) (AVAILABLE ON BASE DECOR W/BVE ONLY)

TRIM LEVEL		SEAT OPT	INTERIOR COLORS			
(Must Specify Seat Option and Interior Color)			Med Gray	Blue	Neutral	Red
N.C. Custom Cloth High Back Reclining Bucket Seats		AV5	92G	26G	52G	79G
EXTERIOR COLORS		Color Code 1	Paint Scheme	Interior & Exterior Combinations Shown are the only Combinations Available		
AUTUMNWOOD, LT (Met)	55U	ZY1			X	
BLUE, TEAL (Met)	36U	ZY1	X		X	
BRONZEMIST, MED. (Met)	76U	ZY1	X		X	
COPPER, DK (Met)	69U	ZY1	X		X	
SILVERMIST (Met)	17U	ZY1	X	X		X
WHITE, IVORY	10U	ZY1	X	X	X	X

BASE DECOR W/ZY2 TWO-TONE APPEARANCE (INCLUDES CLADDING) (REQUIRES BVE RUNNING BOARDS) LS DECOR WITH ZY2 TWO-TONE APPEARANCE (INCLUDES CLADDING)

TRIM LEVEL			SEAT OPT	INTERIOR COLORS			
(Must Specify Seat Option and Interior Color)				Med Gray	Blue	Neutral	Red
N.C. Custom Cloth High Back Reclining Bucket Seats			AV5	92G	26G	52G	79G
EXTERIOR COLORS			Color Code 1	(b)Color Code 2	Paint Scheme	Interior & Exterior Combinations Shown are the only Combinations Available	
AUTUMWOOD, LT (Met)/Bronzemist, Med. (Met)			55U	76Q	ZY2		X
AUTUMWOOD, LT (Met)/Silvermist (Met)			55U	17Q	ZY2		X
BLUE, MED CADET (Met)/Bronzemist, Med. (Met)			25U	76Q	ZY2		X
BLUE, MED CADET (Met)/Autumwood, Lt (Met)			25U	55Q	ZY2		X
BLUE, MED CADET (Met)/Silvermist (Met)			25U	17Q	ZY2	X	X
BLUE, TEAL (Met)/Bronzemist, Med. (Met)			36U	76Q	ZY2		X
BLUE, TEAL (Met)/Autumwood, Lt (Met)			36U	55Q	ZY2		X
BLUE, TEAL (Met)/Silvermist (Met)			36U	17Q	ZY2	X	
BRONZEMIST, MED. (Met)/Autumwood, Lt (Met)			76U	55Q	ZY2		X
COPPER, DK (Met)/Bronzemist, Med. (Met)			69U	76Q	ZY2		X
COPPER, DK (Met)/Autumwood, Lt (Met)			69U	55Q	ZY2		X
COPPER, DK (Met)/Silvermist (Met)			69U	17Q	ZY2	X	
GRAY, MED. CHARCOAL (Met)/Bronzemist, Med. (Met)			14U	76Q	ZY2	X	X
GRAY, MED. CHARCOAL (Met)/Autumwood, Lt (Met)			14U	55Q	ZY2		X
GRAY, MED. CHARCOAL (Met)/Silvermist (Met)			14U	17Q	ZY2	X	X
GREEN, DK FOREST (Met)/Autumwood, Lt (Met)			57U	55Q	ZY2		X
GREEN, DK FOREST (Met)/Silvermist (Met)			57U	17Q	ZY2	X	
RED, LT CARMINE (Met)/Bronzemist, Med. (Met)			53U	76Q	ZY2		X
RED, LT CARMINE (Met)/Autumwood, Lt (Met)			53U	55Q	ZY2		X
RED, LT CARMINE (Met)/Silvermist (Met)			53U	17Q	ZY2	X	
WHITE, IVORY/Bronzemist, Med. (Met)			10U	76Q	ZY2		X
WHITE, IVORY/Autumwood, Lt (Met)			10U	55Q	ZY2		X
WHITE, IVORY/Silvermist (Met)			10U	17Q	ZY2	X	X

(b)Color Code 2 Must Be Ordered as a (+) Option

ASTRO PASSENGER VAN

INTERIOR AND EXTERIOR COLOR AVAILABILITY CHART

PLEASE NOTE: Below are the interior trim color and exterior paint combinations recommended by Chevrolet. They are the only available interior and exterior combinations allowed

LT DECOR WITH ZY1 PAINT (INCLUDES CLADDING)

TRIM LEVEL		SEAT	INTERIOR COLORS		
(Must Specify Seat Option and Interior Color)			Med Gray	Neutral	
Special Cloth High Back Reclining Front Bucket Seats		AV5	92H	52H	
Special Leather High Back Reclining Front Bucket Seats		AV5	922	522	
EXTERIOR COLORS	Color Code 1	Paint Scheme	Recommended Interior Trim Colors		STRIPE COLORS
AUTUMWOOD, LT (Met)	55U	ZY1		X	BRONZEMIST
BLUE, TEAL (Met)	36U	ZY1		X	AUTUMWOOD
BLUE, TEAL (Met)	36U	ZY1	X		SILVERMIST
BRONZEMIST, MED. (Met)	76U	ZY1	X	X	AUTUMWOOD
COPPER, DK (Met)	69U	ZY1		X	AUTUMWOOD
COPPER, DK (Met)	69U	ZY1	X		BRONZEMIST
SILVERMIST (Met)	17U	ZY1	X		BRONZEMIST
WHITE, IVORY	10U	ZY1		X	AUTUMWOOD
WHITE, IVORY	10U	ZY1	X		SILVERMIST

LT DECOR WITH ZY2 TWO-TONE APPEARANCE (INCLUDES CLADDING)

EXTERIOR COLORS	Color Code 1	(a)Color Code 2	Paint Scheme	Recommended Interior Trim Colors		STRIPE COLORS
AUTUMWOOD, LT (Met)/Bronzemist, Med. (Met)	55U	76Q	ZY2		X	BRONZEMIST
AUTUMWOOD, LT (Met)/Silvermist (Met)	55U	17Q	ZY2		X	SILVERMIST
BLUE, MEDIUM CADET (Met)/Bronzemist, Med. (Met)	25U	76Q	ZY2		X	BRONZEMIST
BLUE, MEDIUM CADET (Met)/Autumwood, Lt (Met)	25U	55Q	ZY2		X	AUTUMWOOD
BLUE, MEDIUM CADET (Met)/Silvermist (Met)	25U	17Q	ZY2	X		SILVERMIST
BLUE, TEAL (Met)/Bronzemist, Med (Met)	36U	76Q	ZY2		X	BRONZEMIST
BLUE, TEAL (Met)/Autumwood, Lt (Met)	36U	55Q	ZY2		X	AUTUMWOOD
BLUE, TEAL (Met)/Silvermist (Met)	36U	17Q	ZY2	X		SILVERMIST
BRONZEMIST, MED. (Met)/Autumwood, Lt (Met)	76U	55Q	ZY2		X	AUTUMWOOD
BRONZEMIST, MED. (Met)/Silvermist (Met)	76U	17Q	ZY2	X		SILVERMIST
COPPER, DK (Met)/Bronzemist, Med. (Met)	69U	76Q	ZY2		X	BRONZEMIST
COPPER, DK (Met)/Autumwood, Lt (Met)	69U	55Q	ZY2		X	AUTUMWOOD
COPPER, DK (Met)/Silvermist (Met)	69U	17Q	ZY2	X		SILVERMIST
GRAY, MED. CHARCOAL (Met)/Silvermist (Met)	14U	17Q	ZY2	X		SILVERMIST
GRAY, MED. CHARCOAL (Met)/Bronzemist, Med. (Met)	14U	76Q	ZY2	X	X	BRONZEMIST
GRAY, MED. CHARCOAL (Met)/Autumwood, Lt (Met)	14U	55Q	ZY2		X	AUTUMWOOD
GREEN, FOREST, DK (Met)/Bronzemist, Med. (Met)	57U	76Q	ZY2		X	BRONZEMIST
GREEN, FOREST, DK (Met)/Autumwood, Lt (Met)	57U	55Q	ZY2		X	AUTUMWOOD
GREEN, FOREST, DK (Met)/Silvermist (Met)	57U	17Q	ZY2	X		SILVERMIST
RED, LT CARMINE (Met)/Bronzemist Med. (Met)	53U	76Q	ZY2		X	BRONZEMIST
RED, LT CARMINE (Met)/Autumwood, Lt (Met)	53U	55Q	ZY2		X	AUTUMWOOD
RED, LT CARMINE (Met)/Silvermist (Met)	53U	17Q	ZY2	X		SILVERMIST
WHITE, IVORY/Bronzemist, Med. (Met)	10U	76Q	ZY2		X	BRONZEMIST
WHITE, IVORY/Autumwood, Lt (Met)	10U	55Q	ZY2		X	AUTUMWOOD
WHITE, IVORY/Silvermist (Met)	10U	17Q	ZY2	X		SILVERMIST

(a)Color Code 2 Must Be Ordered as a (+) Plus Option

M/L ASTRO PASSENGER VAN INTRODUCTION

M/L ASTRO PASSENGER VAN

The M/L Astro Passenger Van is offered in three trim levels: "Astro" (standard), "LS" (midlevel) and "LT" (uplevel).

Changes on the Astro Passenger Van for 1999 include:

- Replacing Current Key Heads with Larger Key Heads that will include Brand Logo
- New Running Boards (BVE) Which Will Extend from the Front-Wheel Opening to the Rear-Wheel Opening (requires BX2 body cladding) Interim Availability/Dealer Installed
- New Active Transfer Case on Model L11006 Which Offers "State-of-the-Art" All-Wheel-Drive Technology
- New Improvements to the DK8 Roof Console Include a Trip Computer, Average Fuel Economy, Instantaneous Fuel Economy, Trip Range and Fuel in Addition to Outside Temperature and Compass
- New YC7 Stripe Design
- 4L60E Automatic Transmission Enhancements (M30)
- Three New Exterior Colors

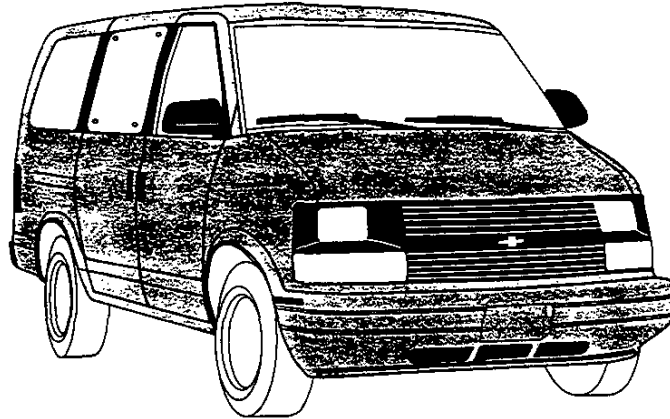

M/L ASTRO PASSENGER VAN

MODEL SELECTION SUMMARY

Use the chart below to choose the model that fits your customer's needs. Please note that the Base Payloads shown reflect the maximum allowable weight of cargo that can be carried in a standard model, including occupants. (They are calculated by subtracting curb weight from GVWR.) To calculate payloads for models with optional equipment, please refer to the WEIGHTS section in the back of this book or consult your 1999 GM PROSPEC. Also, the Maximum Trailer Weights shown on the last page of this section are based on vehicles that are properly equipped. See your Chevrolet Truck Order Guide for specific details.

SERIES	MODEL NUMBER/ BODY CODE/ OPTION CODE	PASSENGER CAPACITY (STD./OPT.)	STANDARD ENGINE/ TRANS.	OPTIONAL ENGINE/ TRANS.	GVWR (LB)	GAWR (LB) FRONT/ REAR	BASE PAYLOAD (LB)
REAR-WHEEL-DRIVE MODEL							
ASTRO PASSENGER VAN	CM11006/ZW9	7/8	4300 V6/A4	—	5950	2800/3150	1764
ALL-WHEEL-DRIVE MODEL							
ASTRO ALL-WHEEL-DRIVE PASSENGER VAN	CL11006/ZW9	7/8	4300 V6/A4	—	6100	3050/3150	1667

POWERTRAIN

Chevrolet offers a variety of rear axle ratios for the M/L Astro Passenger Van. The following charts detail basic engine, transmission, and axle specifications. See your 1999 Chevrolet Truck Order Guide for details.

ENGINE	
	VORTEC 4300 V6
Engine Order Code	L35
SAE Net Horsepower @ rpm	190 @ 4400
SAE Net Torque lb-ft @ rpm	250 @ 2800
Fuel System	SFI
Standard Battery Cold Cranking Amps @ 0° F	600
Standard Alternator Maximum Capacity (Amps)	100

TRANSMISSION	
	ELECTRONIC AUTOMATIC 4-SPEED W/OVERDRIVE AND TORQUE CONVERTER CLUTCH (4L60-E)
Order Code	M30
Gear Ratios	
First	3.06
Second	1.63
Third	1.00
Fourth	0.70
Reverse	2.29

AXLES					
	REAR AXLE			FRONT AXLE (ALL-WHEEL-DRIVE MODEL ONLY)	
Make	GM			GM	
Capacity (lb)	3150			3050	
Pinion and Ring Gear Type	Hypoid			Hypoid	
Axle Ratio Code	GU5	GU6	GT4	GU6	GT4
Ratio	3.23	3.42	3.73	3.42	3.73
Pinion Teeth	13	12	11	12	11
Ring Gear Teeth	42	41	41	41	41
Ring Gear Diameter (in.)	7.625	7.625	7.625	7.25	7.25

Note: Axle ratio depends on model, powertrain, and emissions selected.

M/L ASTRO PASSENGER VAN

TRIM LEVELS

Chevrolet offers M/L Astro Passenger Van in three trim levels: "Astro," "LS," and "LT". See your 1999 Chevrolet Truck Order Guide for more details.

CHASSIS EQUIPMENT		ASTRO (STANDARD)	LS (YC6)	LT (YC7)
KEY: ■ = STANDARD, --- = NOT INCLUDED				
BRAKES	Power-assisted front disc/rear drum. (Includes brake/transmission shift interlock.)	■	■	■
EXHAUST	Single; with aluminized stainless steel tailpipe and muffler.	■	■	■
FRAME	Integral body design with boxed section front stub frame.	■	■	■
FUEL TANK	25-gallon (approx.) capacity.	■	■	■
REAR AXLE	Hypoid, semi-floating.	■	■	■
SHOCK ABSORBERS	Front: 32mm; Rear: 32mm.	■	■	■
STABILIZER BAR	4x2: (Front) 1.26 in. All-wheel drive: (Front) 1.18 in.	■	■	■
STEERING	Variable Power Assist.	■	■	■
SUSPENSION, FRONT	4x2: Independent w/coil springs. All-wheel drive: Independent w/torsion bars.	■	■	■
SUSPENSION, REAR	Steel leaf springs.	■	■	■

EXTERIOR EQUIPMENT		ASTRO (STANDARD)	LS (YC6)	LT (YC7)
BUMPERS	Front and rear painted body color with rear combination top-step surface.	■	■	■
CLADDING	Lower bodyside.	---	■	■
DOORS	Driver and passenger front side, sliding RH side door and RH/LH rear load doors.	■	■	■
GRILLE	Molded, composite; painted argent. Deluxe front appearance with bright highlights.	■	---	---
HEADLAMPS	Single halogen sealed beam. Composite halogen.	---	■	■
HORN	Dual high-note and low-note.	■	■	■
KEYLESS ENTRY	Remote.	---	■	■
LICENSE PLATE MOUNTING (FRONT)	Molded in fascia.	■	■	■
LUGGAGE RACK	Black.	---	■	■
MIRRORS	Below-eyeline type, black. Head size LH: 5.0" x 8.5", RH: 5.25" x 9.0". Dual electric below-eyeline type, black. Head size LH: 5.0" x 8.5", RH: 5.25" x 9.0".	■	---	---
SPARE TIRE CARRIER	Winch-type; mounted under floor at rear.	■	■	■
SPARE TIRE/WHEEL	Compact; mounted under floor at rear.	■	■	■
STRIPING	Color-keyed at beltline.	---	---	■
TIRES	Four P215/75R15 all-season steel-belted radial blackwall.	■	■	■
WHEELS	Four 15.0" x 6.0" argent steel wheels. Includes bright metal center caps with black trim. Four 15.0" x 6.5" styled steel wheels chrome clad. Four 15.0" x 6.5" brushed aluminum wheels.	■	---	---
WINDOW PILLARS	Black.	■	■	■
WIRING	Six-wire harness for trailering purposes (includes CHMSL).	■	■	■

INTERIOR EQUIPMENT		ASTRO (STANDARD)	LS (YC6)	LT (YC7)
AIR CONDITIONING	Front.	■	■	■
ARMRESTS	RH and LH front door.	■	■	■
ASSIST HANDLES	Front at RH "A" pillar and rear passenger at RH "B" pillar.	■	■	■
CIGARETTE LIGHTER	Includes ashtray lamp.	■	■	■
COAT HOOKS	Three LH and two RH.	■	■	■
CONSOLE, OVERHEAD	Includes dome lamp, four map-reading lamps, outside temperature gauge, electronic compass, trip odometer and storage compartments.	---	■	■
CONVENIENCE NET	Removable black net located in rear compartment.	---	■	■
DOOR LOCK SYSTEM	Power. (Includes a two-sided key with brand logo.) Keyless remote. Includes two key fobs.	---	■	■
DOOR STEPWELL	Black.	■	■	■
DOOR TRIM	Color-keyed expanded vinyl on driver's and passenger doors with cloth window sills, lower carpet inserts, map pockets, armrests, radio speakers and door reflectors. Door reflectors include lights.	■	■	■
FLOOR COVERING	Color-keyed carpeting on wheelhousings and entire floor. Floor carpeting treated with Scotchgard™ Fabric Protector.	■	■	■
FLOOR MATS	Color-keyed rubber floor mats at all seating positions.	---	■	■

¹ Two-sided key with brand logo standard.

M/L ASTRO PASSENGER VAN

INTERIOR EQUIPMENT (CONT.)				
KEY: ■ = STANDARD, — = NOT INCLUDED		ASTRO (STANDARD)	LS (YC6)	LT (YC7)
GAUGES	Coolant temperature, fuel level, odometer, oil pressure, speedometer, trip odometer and voltmeter.	■	■	■
GLASS, FULL-BODY	Solar-Ray® tint: all windows. Solar-Ray® deep-tint: all windows except windshield, driver's window and front passenger window.	■	—	—
GLASS, SWINGOUT	Included on sliding side door and left-front quarter panel. Swingout glass also included on rear cargo door.	■	■	■
GLOVE BOX	Located in front face of engine cover extension. Includes two beverage holders on top of engine cover extension.	■	■	■
HEADLAMP WARNING TONE	Headlamps on.	■	■	■
HEADLINER	Full-length, two-piece, color-keyed, foam-backed cloth.	■	■	■
HEATER	Includes front heater with windshield and side-window defoggers. Also includes heat ducts located under the driver's and front passenger bucket seats that provide heat to intermediate passengers.	■	■	■
LAMPS	Stepwell, storage compartment and three dome lamps (front, middle, rear) with front, rear and sliding door-activated switches. Includes door jamb override button and delayed illuminated entry. Front and middle entry lamps also include adjustable reading lamps.	■	■	■
MAP NET	Storage pouch located on passenger side of engine cover extension.	■	■	■
MIRROR	10-inch rearview.	■	■	■
POWER OUTLETS	Two covered electrical accessory outlets located on the passenger side of engine cover extension (in addition to cigarette lighter). One covered electrical accessory outlet located near the floor in the left-hand rear-quarter panel.	■	■	■
RADIOS	Electronically tuned AM/FM stereo with seek-scan, digital clock, six speakers and fixed mast antenna. Electronically tuned AM/FM stereo with seek-scan, digital clock, cassette, six speakers and fixed mast antenna.	■	—	—
SEATS	8-passenger seating with two custom cloth high-back adjustable reclining front bucket seats that include dual folding armrests, map pockets and adjustable manual lumbar support and two 3-passenger custom cloth folding middle and rear bench seats. Bench seats are removable, adjust fore and aft and include head restraints. Scotchgard™ Fabric Protector on cloth seats. 8-passenger seating with two special cloth high-back adjustable front bucket seats with reclining seatbacks, dual folding armrests and adjustable headrests and two 3-passenger special cloth folding middle and rear bench seats. Bench seats include fold-down center consoles with convenience trays and beverage holders. Bench seats are also removable and adjust fore and aft. Scotchgard™ Fabric Protector on cloth seats.	■	■	—
SECURITY	PassLock® theft deterrent system.	■	■	■
SPEED CONTROL	Electronic.	—	■	■
STEERING COLUMN	Tilt-Wheel™.	—	■	■
STEERING WHEEL	Black 4-spoke; with anti-theft locking feature. Black leather-wrapped; with anti-theft locking feature.	■	—	■
STORAGE COMPARTMENTS	Left-hand second seat area – Includes an ashtray, upper storage bin and beverage holder. Also includes full-length lower storage bin. Left-hand third seat area – Includes an upper storage bin, storage compartment and beverage holder. Also includes a storage compartment in the lower corner. Right-hand third seat area – Includes an upper storage bin, storage compartment and beverage holder.	■	■	■
SUNSHADES	RH and LH padded color-keyed cloth with dual visor mirrors, map bands and extenders. RH and LH padded color-keyed cloth with dual adjustable lighted visor mirrors (including dimmer feature), map bands, auxiliary visors and extenders.	■	—	—
TOOLS	Screw-operated scissor-type jack with ratchet handle and extension and two wheel blocks. Located behind side panel at right rear.	■	■	■
WINDOWS	Power.	—	■	■
WINDSHIELD WIPERS	Intermittent.	■	■	■

SAFETY EQUIPMENT				
AIR BAGS*	Driver and front seat passenger (next generation).	■	■	■
BRAKES	4-wheel anti-lock.	■	■	■
DOOR BEAMS	Side-door guard beams for front side doors and sliding side door. Sliding door includes child safety lock.	■	■	■
LAMPS	Daytime running lamps/center high-mounted stoplamp (CHMSL).	■	■	■
SEAT BELTS	Lap and shoulder.	■	■	■
STEERING COLUMN	Energy-absorbing (also includes anti-theft locking).	■	■	■

*Always wear your safety belts.

M/L ASTRO PASSENGER VAN

PREFERRED EQUIPMENT GROUPS

Preferred Equipment Groups (PEGs) are convenient option packages that can save your customers money. They would pay appreciably more by buying all the options in a Preferred Equipment Group as individual options. (Savings based on a comparison of Manufacturer's Suggested Retail Price of option packages versus MSRP of individual options purchased separately.) See your 1999 Chevrolet Truck Order Guide and Vehicle Price Schedule for specific information and prices.

OPTIONS

These options can be ordered individually in addition to the Preferred Equipment Groups if not already included. See your 1999 Chevrolet Truck Order Guide for specific availability and restrictions. The Option Code is listed in **bold type**.

<i>Air Conditioning (front and rear includes 105-amp alternator)</i>	C69
<i>Axles, Rear</i>	
3.23 (CM 11006 only)	GU5
3.42	GU6
3.73	GT4
Locking Differential	G80
<i>Body Code</i>	
Standard Body Equipment	ZW9
Dutch Doors (includes electric release, intermittent wiper/washer (reqs. power door locks)	E54
Cargo Net	AP9
Carrier, Luggage (black)	V54
Cold Climate Package (includes engine block heater, coolant protection)	V10
<i>Console, Roof</i>	
Without Electronics	DK6
With Electronics	DK8
<i>Defogger, Rear-Window Electric (requires E54 dutch doors)</i>	C49
<i>Door Locking System, Power</i>	AU3
<i>Emissions</i>	
Federal	FE9
Massachusetts/New York/Connecticut/Rhode Island/ New Jersey	NG1
California	YF5
CA/MA/NY/CT/RI/NJ Emissions override	NB8
Federal Emissions Override	NC7
<i>Engines:</i>	
VORTEC 4300 SFI V6	L35
<i>Floor Mats, Color-keyed Rubber at All Seating Positions (included with YC6/YC7)</i>	B37
<i>Glass</i>	
Deep-Tinted Solar-Ray® (Included with YC6/YC7)	AJ1
<i>Grille, Deluxe Appearance with Bright Inserts; Includes Composite Headlamps and Body-Color Bumpers</i>	TL1
<i>GVWR</i>	
5950-lb (CM11006 only)	C6M
6100-lb (CL11006 only)	C5M
Heater, Auxiliary Rear	C36

<i>Lock, Keyless Remote</i>	AU0
<i>Mirrors, Black Exterior Electric Remote (mirror head LH: 5.0" x 8.5"; RH: 5.25" x 9.0")</i>	D48
<i>Molding, Bodyside</i>	B74
<i>Paint, Exterior:</i>	
Solid	ZY1
Two-Tone Appearance (YC5 requires BVE running boards) ..	ZY2
<i>Radio Equipment</i>	
ETR AM/FM Stereo w/Seek-Scan, Digital Clock, Cassette and Eight Speakers	UM6
ETR AM/FM Stereo w/Seek-Scan, Automatic Tone Control, Cassette Tape, Digital Clock, Theft-Lock™, Speed-Compensated Volume and Eight Speakers	UL0
ETR AM/FM w/Seek-Scan, Automatic Tone Control, Compact Disc Player, Digital Clock, Theft-Lock™, Speed-Compensated Volume and Eight Speakers	UN0
ETR AM/FM Stereo w/Seek-Scan, Automatic Tone Control, Cassette, Compact Disc Player, Digital Clock, TheftLock™, Speed-Compensated Volume and Eight Speakers	UPO
Rear Seat Radio Controls and Jacks (requires UL0/UPO radio; not available on YC5 Base decor)	UK6
<i>Running Boards (dealer installed/intermittent wiper) (includes cladding)</i>	BVE
<i>Seating Arrangements</i>	
7-Person Seating: 4 High-Back Reclining Bucket Seats and 3-Passenger Bench	ZP7
8-Person Seating: 2 Front High-Back Reclining Bucket Seats and Two 3-Passenger Bench Seats (included with YC6 and YC7)	ZP8
Seat, Six-way Power Driver's	AG1
Seat, Six-way Power Passenger (requires Power Driver's seat AG1; not available with underseat storage compartment)	AG2

<i>Seat, Leather</i>	
Gray (reqs. YC7)	922
Neutral (reqs. YC7)	522
<i>Seat Package (includes inboard and outboard armrests, map pockets and manual lumbar support. Available on YC5 base decor with cloth seat only)</i>	AN0
<i>Steering Wheel</i>	
Black Leather-Wrapped (included with YC7)	NP5
Tilt-Wheel and Speed Control	Z03
<i>Trailer Package, Heavy-Duty (includes hitch platform and eight-wire harness)</i>	Z82
<i>Transmission, 4-speed Electronically Controlled Automatic w/Overdrive ..</i>	M30
<i>Transmitter, 3-Channel Garage Door Opener (reqs. DK8 Roof Console).....</i>	UG1
<i>Wheels</i>	
Brushed Aluminum (included with YC7)	PF3
Styled, Steel (painted sparkle silver; included with YC6)	PA6
Styled Steel (chrome clad)	PC2

TIRES

KEY: ALS = ALL-SEASON SBR = STEEL-BELTED RADIAL PLY BW = BLACKWALL WOL = WHITE OUTLINED LETTER

TIRE DESCRIPTION		ORDERING CODE
P215/75R15	ALS/SBR/BW	QCU
P215/75R15	ALS/SBR/WOL	QCM

M/L ASTRO PASSENGER VAN

DIMENSIONS

MODEL		ASTRO PASSENGER VAN	ASTRO ALL-WHEEL-DRIVE PASSENGER VAN
MODEL NUMBER		CM11006	CL11006
EXTERIOR DIMENSIONS			
BODY			
Wheelbase (in.)	L101	111.2	111.2
Overall Length (in.)	L103	189.8	189.8
Overall Height (in.) Nominal	H431	74.9	74.8
Maximum Width (in.)	W103	77.5	77.5
Bumper to Axle (in.) Front	L104	32.5	32.5
Rear	L105	46.0	46.0
Ground to Top of Rear Load Floor (in.)	H502	25.9	25.8
Ground Clearance (in.) Front/Rear	H148/H153	6.8/7.4	6.8/7.4
Step-Up Height (in.) Front Door	H130	18.6	18.6
Side Load Door	H131	20.2	20.2
Side Load Door Opening Height (in.)	H505	46.8	46.8
Opening Width (in.)	L508	34.5	34.5
Rear Load Door Opening Height (in.)	H202	42.0	42.0
Opening Width (in.)	W204	57.2	57.2
Turning Diameter Curb-to-Curb (ft)		42.7	42.2
Track Width (in.) Front/Rear	W101/102	65.1/65.1	65.1/65.1
SIGN PANEL AREA			
Side Panel (in.)		18 x 90.5	18 x 90.5
Front Door (in.)		18 x 40	18 x 40

* Height from ground level to the surface of the stepwell.

INTERIOR DIMENSIONS			
Headroom (in.) H61/H63/H86 Front/Middle/Rear		39.2/37.9/38.7	39.2/37.9/38.7
Legroom (in.) L34/L51/L86 Front/Middle/Rear		41.6/36.5/38.5	41.6/36.5/38.5
Shoulder Room (in.) W3/W4/ Front/Middle/Rear	W85	64.0/67.1/67.1	64.0/67.1/67.1
Hip Room (in.) W5/W6/W86 Front/Middle/Rear		64.9/50.9/57.1	64.9/50.9/57.1
Load Floor Length (in.) to Console	L512	126.0	126.0
w/Front/Middle	L202/L203	98.6/61.7	98.6/61.7
w/Rear Seat	L509	28.4	28.4
Interior Height (in.)	H201	47.2	47.2
Interior Width (in.) Between Wheelhousings	W201	51.6	51.6
Cargo Volume (cu ft) w/Front/Middle		170.4/104.4	170.4/104.4
w/Rear Seat		41.3	41.3

M/L ASTRO PASSENGER VAN

TRAILERING

Weight-carrying hitch limit: 2000-lb trailer with 200-lb tongue weight. Weight distributing hitch and sway control required over 2000-lb trailer weight.

ENGINE/ TRANSMISSION		VORTEC 4300 V6/ AUTOMATIC	
MAXIMUM TRAILERING			
MODEL	AXLE RATIO	MAX. TONGUE LOAD/ MAX. TRAILER WEIGHT (lb)	
2WD M-VAN	3.23	14500	
	3.42	15000	
	3.73	15500	
AWD L-VAN	3.42	14500	
	3.73	15000	

*Trailer tongue weight should be 10 to 15% of total loaded trailer weight (up to 750 lb).

Notes:

- 1. Maximum trailer weight is calculated assuming the driver and one passenger are in the tow vehicle and it has all required trailering equipment.
- 2. The weight of additional optional equipment, passengers and cargo in the tow vehicle must be subtracted from the maximum trailer weight.
- 3. 200 heavy-duty Trailering Equipment Package includes weight-distributing hitch platform and 8-wire trailer harness.
- 4. Base cooling system includes all content required to attain maximum rating. No optional cooling equipment available.

Astro Cargo Van



Focus/Feature

The 1999 Focus/Feature vehicle is the Astro Cargo Van with rear-wheel drive. Ideal for commercial fleets, Astro also appeals to recreational buyers as an excellent conversion platform. (image above)

Ordering recommendations:

The recommended Astro Cargo Van with rear-wheel-drive content, based on anticipated national sales volume, is listed below to assist your dealership in ordering.

Major standard equipment includes:

- Air Conditioning
- Next Generation Driver and Front-Passenger Air Bags*
- 4-Wheel Anti-Lock Brake System (ABS)
- 2-Passenger Seating with High-Back Bucket Seats.

Suggested individual options:

- Convenience Groups:
 - Power Windows, Power Door Locks
 - Tilt-Wheel™ Steering Column and Electronic Speed Control
- 15" Painted Styled-Steel Wheels.

Popular colors: Ivory White, Silvermist Metallic, Medium Bronzemist Metallic.

*Always use safety belts and proper child restraints, even with Next Generation air bags. See the owner's manual for more safety information.

Astro Cargo Van Owners ... a Closer Look

Complete with the toughness characteristics of a truck and the roominess of a midsize van, Astro Cargo Van finds its niche with fleet buyers and tradespeople who need a vehicle to help them get the job done efficiently and economically.

About Dealer Order Guide inserts

The Dealer Order Guide inserts are your first look at Chevy Truck models for 1999. This information is preliminary and is subject to change. Use these inserts to assist in ordering your initial shipments. Most of your volume should come from the Focus vehicle, which is the model chosen for its saleability. It is equipped with the product features that customers want most. (Model, PEG and optional equipment vary by region.) Refer to the Retail Sales Analysis (RSA) to verify or select your dealership's Focus vehicle content. There is also the Feature vehicle, which is the "image" model Chevrolet will profile most in its advertising. This vehicle is meant to capture attention and create consumer awareness.

Astro Cargo Van is loaded with service advantages fleets will appreciate.

Holding down service costs is a major concern for today's cost-conscious fleet operators. Astro Cargo Van boasts easy-to-service features that can help fleet operators do just that.

Included are:

- Bolt-On Fenders for Improved Serviceability
- Quick-Removal Engine Latch Covers
- Engine Removal from the Front
- One-Piece Inner-Quarter Panels (help to protect outer panels from being damaged by shifting cargo)
- Platinum-Tip Spark Plugs Can Last Up to 100,000 Miles*
- Automatic Transmission Fluid Can Last Up to 100,000 Miles*
- Extended-Life Engine Coolant Can Last Up to Five Years or 150,000 Miles*
- Stainless-Steel Exhaust System Designed to Resist Corrosion.

Point out these cost-saving features to fleet operators — especially those who perform their own maintenance.

*Maintenance needs vary with different uses and driving conditions. See owner's manual for details.

Trim Colors

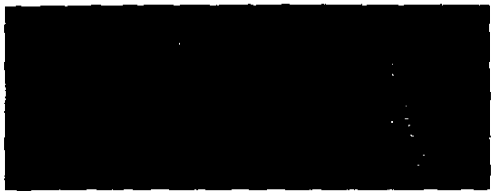

Custom Vinyl available in Medium Gray, Navy, Neutral and Ruby.



Custom Cloth (LS models) available in Medium Gray, Navy, Neutral and Ruby.

Seat Styles

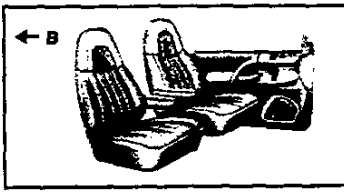
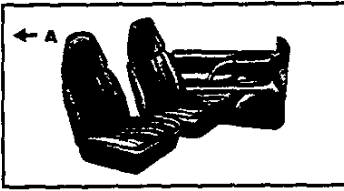

- A. Standard Custom Vinyl high-back reclining bucket seats — include driver and front-passenger seats.
- B. Optional Custom Cloth high-back reclining bucket seats — include driver and front-passenger seats.

Wheels

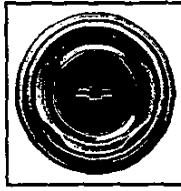

15" x 6" standard steel, painted argent with bright and black hubcap.



(RPO PA6) 15" x 6.5" styled-steel, painted (optional).

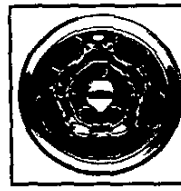

(RPO PC2) 15" x 6.5" chrome-clad styled-steel (optional).



(RPO PF3) 15" x 6.5" new brushed-aluminum (optional with YF7 Uppfitter Package).

Most Popular Exterior Colors with Corresponding Interior Color Availability

Interior Material Colors				
	Medium Gray	Navy	Neutral	Ruby
Exterior Colors				
Ivory White	✓	✓	✓	✓
Silvermist Metallic	✓	✓		✓
Medium Bronzemist Metallic	✓		✓	

See order guide for color availability by model.

Most Popular Exterior Colors by Percentage

Ivory White (#10)	55%
Silvermist Metallic (#17)	7%
Medium Bronzemist Metallic (#76)	6%
Other colors	32%

NOTE: New Astro Cargo Van exterior colors are Medium Charcoal Gray Metallic (#14) and Medium Bronzemist Metallic (#76). Dark Purple Metallic (#05), and Cherry Ice Metallic (#59) have been cancelled.

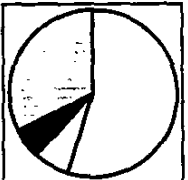

Astro Cargo Van

P.D.S.E.I. is a term used to help organize and explain key features and benefits in five major categories a customer needs and wants. Overall improvements, changes and deletions are highlighted. Please review the supplied information, keeping in mind that this material is provided to you before production start-up — and may change.



P.D.S.E.I. (New-for-'99 features appear in green.)

PERFORMANCE



- **ACTIVE TRANSFER CASE** (AWD models) — replaces the current all-wheel drive system, and offers state-of-the-art All-Wheel-Drive technology for enhanced traction and added security regardless of road conditions.
- **AUTOMATIC TRANSMISSION ENHANCEMENTS** — Vamac pump cover seals make possible better sealing. New clutch plate material is used, which is designed for improved durability and performance.
- **INTEGRAL VARIABLE-ASSIST POWER STEERING** — for excellent road feel.
- **STANDARD VORTEC 4300 V6 ENGINE WITH SEQUENTIAL FUEL INJECTION (SFI)** — provides smooth, quiet power as the biggest engine in its class.*

DURABILITY



- **NEW STARTER MOTOR** — designed for enhanced quality, dependability and reliability.
- **PLATINUM-TIP SPARK PLUGS** — can help Vortec engines travel up to 100,000 miles before their first scheduled tune-up.†
- **EXTENDED-LIFE ENGINE COOLANT** — has a first scheduled replacement interval of 5 years or 150,000 miles, whichever comes first.†
- **BUMPER TO BUMPER WARRANTY** — a 3-year/36,000-mile, no deductible, limited warranty, 24-Hour Roadside Assistance via a toll-free hot line and Courtesy Transportation,** if vehicle ever needs warranty work.

SAFETY



- **OPTIONAL OUTSIDE POWER MIRRORS** (available on models with or without YF7 Upfitter Package) — LH and RH remote control. Enhances driver rearward visibility.
- **NEXT GENERATION DRIVER AND FRONT-PASSENGER AIR BAGS††** — designed to help protect against injury in certain moderate to severe frontal collisions.
- **4-WHEEL ANTI-LOCK BRAKE SYSTEM (ABS)** — standard on all models, helps reduce wheel lockup while braking hard on most slippery surfaces.

EXTERIOR



- **AVAILABLE RUNNING BOARDS** (optional with YF7 Upfitter Package) — makes entry and exit easier (dealer-installed).
- **TWO NEW EXTERIOR COLORS** — Medium Charcoal Gray Metallic and Medium Bronzemist Metallic.
- **BASECOAT/CLEARCOAT PAINT** — helps reduce damage caused by water-spotting, acid rain and environmental etch.
- **TWO-SIDE GALVANIZED STEEL** — on major exterior body panels (except roof), makes additional rustproofing unnecessary.
- **OPTIONAL LOWER-BODY CLADDING** (YF7 Upfitter Package only) — adds a handsome styling touch.
- **AVAILABLE DUTCH DOORS** — for greater loading/unloading flexibility.

INTERIOR



- **OPTIONAL ROOF CONSOLE WITH ELECTRONICS AND TRIP COMPUTER** (available with YF7 Upfitter Package) — includes electronic compass, outside temperature display, average and instantaneous fuel economy, trip range, fuel used and elapsed time.
- **POWER WINDOWS AND DOOR LOCKS NOW STANDARD WITH YF7 UPFITTER PACKAGE** — for greater customer satisfaction.
- **UP TO 170 CU. FT. OF CARGO CAPACITY** — the most cargo capacity in its class.*

*Excludes other GM vehicles. †Maintenance needs vary with different uses and driving conditions. See owner's manual for details. **At participating dealerships. ††Always use safety belts and proper child restraints, even with Next Generation air bags. See the owner's manual for more safety information.

Competitive Models

- Dodge Ram Van
- Dodge Caravan C/V

New for 1999

- A new active transfer case replaces the current all-wheel-drive system. It offers state-of-the-art All-Wheel-Drive technology in place of the current All-Wheel-Drive system. The vehicle will normally operate in 2WD until the system senses rear wheel slip, at which time it will transfer torque to the front axle. The system consists of a new transfer case, control module and electrical harness.
- Transmission enhancements include a revised check ball pocket designed to reduce uneven load characteristics and minimize wear. Vamac pump cover seals replace the current polyacrylic material for improved overall sealing. New clutch plate material is formulated to improve durability and performance.
- An optional roof console with trip computer (available on models with YF7 Upfitter Package) is a highly functional addition to Astro Van for 1999. In addition to the usual console features like a compass and outside temperature readout, the new trip computer displays average fuel economy, instantaneous fuel economy, trip range, fuel used and elapsed time. A roof console with convenient storage and four adjustable reading lights only is also available.
- Available new dealer-installed running boards on Astro models with body cladding enhance the styling and utility of Astro for 1999.

Deletions

- Two exterior colors have been deleted for 1999: Dark Purple Metallic and Cherry Ice Metallic and have been replaced by two new colors: Medium Charcoal Gray Metallic and Medium Bronzemist Metallic.
- Electronic Variable Orifice (EVO) feature has been deleted from integral variable-assist power steering.

Forecasted Percent of Mix

SERIES	
RWD	75%
AWD	25%
Total	100%
ENGINES	
Vortec 4300 V6 SFI	100%
Total	100%
TRANSMISSIONS	
4-Speed Electronically Controlled Automatic with Overdrive	100%
Total	100%

Other Information on Significant Features

- Chevy Astro Cargo Van boasts the Vortec 4300 V6 SFI engine for smooth idle and near-instantaneous starts. Strong torque, high power output and smooth operation make the Vortec V6 engine an outstanding performer.
- Chevy Astro Cargo Van provides excellent conversion van opportunities. Astro conversion van goes a long way to enhance the enjoyment of Astro Van owners, especially those who are recreationally minded.

1999 ASTRO CARGO HIGHLIGHTS

NEW FOR 1999

INTERIOR

- **New roof console with convenient storage only (optional on Base model)**
- **New roof console with trip computer, compass and temp gage (optional with Upfitter Package)**

TWO NEW EXTERIOR COLORS

- **Medium Bronzemist Metallic**
- **Medium Charcoal Gray Metallic**

POWERTRAIN

- **New active transfer case on ALL-WHEEL-DRIVE models**

ASTRO CARGO VAN

STANDARD EQUIPMENT SUMMARY

CHASSIS

ALTERNATOR: 100 AMP
BRAKES: POWER ASSISTED FRONT DISC, REAR DRUM, 4WHL ANTI-LOCK
BRAKE/TRANS: BRAKE/TRANSMISSION SHIFT INTERLOCK
ENGINE: VORTEC 4300 V6 SFI (INCLS ENGINE OIL COOLER, H.D. RADIATOR AND
TRANS. OIL COOLER)
FUEL CAPACITY: 25 GALLON
STEERING: VARIABLE POWER ASSIST
TRANSMISSION: 4-SPEED ELECTRONICALLY CONTROLLED AUTOMATIC W/OVERDRIVE

INTERIOR

AIR BAGS: DRIVER AND FRONT PASSENGER (NEXT GENERATION)
AIR CONDITIONING: FRONT
ASSIST HANDLE: PASSENGER SIDE
DOOR BEAMS: DRIVER, PASSENGER AND SLIDING SIDE DOOR
FABRIC PROTECTOR: SCOTCHGARD: ON OPTIONAL CLOTH TRIMS
FLOOR COVERING: EMBOSSED FRONT BLACK RUBBER MAT
GAUGES: COOLANT TEMPERATURE, FUEL LEVEL, ODOMETER, OIL
PRESSURE, SPEEDOMETER, TRIP ODOMETER AND
VOLTMETER
GLASS: TINTED; SOLAR-RAY ALL WINDOWS
LIGHTING: STEPWELL LAMPS, STORAGE COMPARTMENT LAMP, THREE DOME
LAMPS WITH FRONT, REAR AND SLIDING DOOR ACTUATED
SWITCHES, DOOR LAMP DEFEAT SWITCH
DELAYED ILLUMINATED ENTRY LAMPS
POWER POINTS: TWO FRONT (IN ADDITION TO CIGARETTE LIGHTER)
RADIO: ELECTRONICALLY TUNED AM/FM STEREO W/SEEK-SCAN AND
DIGITAL CLOCK
SEATING: FRONT HIGH BACK BUCKET DRIVER AND PASSENGER SEATS W/ALL VINYL TRIM
SECURITY: PASSLOCK THEFT DETERRENT SYSTEM
STEERING WHEEL: BLACK 4-SPOKE WITH ANTI-THEFT LOCKING FEATURE
SUNSHADES: LH AND RH PADDED COLOR-KEYED VINYL W/MAP BANDS
WARNING TONE: HEADLAMP-ON

ASTRO CARGO VAN

EQUIPMENT SUMMARY

EXTERIOR

BUMPERS: FRONT, GRAINED AND MOLDED IN COLOR GRAY/REAR PAINTED GRAY W/STEP PAD
DOORS: SLIDING RH SIDE DOOR RH AND LH REAR LOAD DOORS
GRILLE: MOLDED, COMPOSITE PAINTED ARGENT
LIGHTS: HALOGEN SEALED BEAMS
U.S. DAYTIME RUNNING LIGHTS
MIRRORS: BELOW-EYE-LINE, FOLD-AWAY, PAINTED BLACK
SPARE TIRE: COMPACT SPARE TIRE AND WHEEL MOUNTED UNDER FLOOR AT REAR
WHEELS: 15 X 6 STEEL, PAINTED ARGENT
WIPERS: INTERMITTENT

ASTRO CARGO VAN

STANDARD EQUIPMENT SUMMARY

CHASSIS

ALTERNATOR: 100 AMP
BRAKES: POWER ASSISTED FRONT DISC, REAR DRUM, 4WHL ANTI-LOCK
BRAKE/TRANS: BRAKE/TRANSMISSION SHIFT INTERLOCK
ENGINE: VORTEC 4300 V6 SFI (INCLS ENGINE OIL COOLER, H.D. RADIATOR AND
TRANS. OIL COOLER)
FUEL CAPACITY: 25 GALLON
STEERING: VARIABLE POWER ASSIST
TRANSMISSION: 4-SPEED ELECTRONICALLY CONTROLLED AUTOMATIC W/OVERDRIVE

INTERIOR

AIR BAGS: DRIVER AND FRONT PASSENGER (NEXT GENERATION)
AIR CONDITIONING: FRONT
ASSIST HANDLE: PASSENGER SIDE
DOOR BEAMS: DRIVER, PASSENGER AND SLIDING SIDE DOOR
FABRIC PROTECTOR: SCOTCHGARD: ON OPTIONAL CLOTH TRIMS
FLOOR COVERING: EMBOSSED FRONT BLACK RUBBER MAT
GAUGES: COOLANT TEMPERATURE, FUEL LEVEL, ODOMETER, OIL
PRESSURE, SPEEDOMETER, TRIP ODOMETER AND
VOLTMETER
GLASS: TINTED; SOLAR-RAY ALL WINDOWS
LIGHTING: STEPWELL LAMPS, STORAGE COMPARTMENT LAMP, THREE DOME
LAMPS WITH FRONT, REAR AND SLIDING DOOR ACTUATED
SWITCHES, DOOR LAMP DEFEAT SWITCH
DELAYED ILLUMINATED ENTRY LAMPS
POWER POINTS: TWO FRONT (IN ADDITION TO CIGARETTE LIGHTER)
RADIO: ELECTRONICALLY TUNED AM/FM STEREO W/SEEK-SCAN AND
DIGITAL CLOCK
SEATING: FRONT HIGH BACK BUCKET DRIVER AND PASSENGER SEATS W/ALL VINYL TRIM
SECURITY: PASSLOCK THEFT DETERRENT SYSTEM
STEERING WHEEL: BLACK 4-SPOKE WITH ANTI-THEFT LOCKING FEATURE
SUNSHADES: LH AND RH PADDED COLOR-KEYED VINYL W/MAP BANDS
WARNING TONE: HEADLAMP-ON

ASTRO CARGO VAN

MODEL AND BODY

Description	Model No.	Body	Wheelbase
Rear-Wheel Drive Model			
Astro Van	CM11005	ZW9	111.2"

Description	Model No.	Body	Wheelbase
All-Wheel Drive Model			
Astro Van	CL11005	ZW9	111.2"

GVWR SELECTOR (MUST SPECIFY)

GVW RATING (LBS.)	Minimum Equipment Required for GVW Rating			Restrictions
	(a) GAWR (LBS.)			
	Front	Rear		
C5G	2800	3150		CM11005 Only
C7X	3050	3150		CL11005 Only

(a) GAWR's shown are the minimum for each axle with equipment listed. Other GAWR's are available and they are determined as the minimum capacity of either axle or springs or tires.

CAPACITIES

CM11005		CL11005	
SPRINGS:	AXLES:	SPRINGS:	AXLES:
FRONT	FRONT	FRONT	FRONT
2800 Base	2800 Base	3050 Base	3050 Base
REAR	REAR	REAR	REAR
3150 Base	3150 Base	3150 Base	3150 Base

POWER TEAMS (Must Specify Engine, Transmission and Rear Axle)

(Consult GVWR Selector for Minimum Equipment Required)

ENGINE	TRANSMISSION	AXLES			GVWR
	(Auto)	3.23	3.42	3.73	
CM11005					
L35 Vortec 4300 SF1 V6	M30	GU5	GU6	GT4	5600
CL11005					
L35 Vortec 4300 SF1 V6	M30	—	GU6	GT4	5850

ASTRO CARGO VAN

No Deletions Allowed. Additional Options/Upgrades (where Indicated)
May Be Ordered from the Additional Option Listing

MUST ORDER 1SA

		1SA
N.C. Preferred Equipment Group		
Body (Standard) (a)	ZW9	X
(a) May Substitute E54		

ADDITIONAL OPTIONS

	ACKNOWLEDGMENTS:
R8S	Multiple Order Numbers
R8T	Preliminary Invoice
YG6	AIR CONDITIONING NOT DESIRED
	AXLE, REAR: (MUST SPECIFY)
GU5	3.23 Ratio (CM11005 Only)
GU6	3.42 Ratio
GT4	3.73 Ratio
G80	Locking Differential
	BODY CODE:
ZW9	Standard Body Equipment
E54	Dutch Doors (Incls Wiper/Washer and Electric Release) (Reqs AU3 Power Door Locks)
V10	COLD CLIMATE PACKAGE: (Incls Engine Block Heater and Coolant Protection)
	CONVENIENCE GROUPS:
ZQ2	Power Windows and Power Door Locks
ZQ3	Tilt Wheel and Speed Control
C49	DEFOGGER: Rear Window Electric (Reqs E54 Body)
AU3	DOOR LOCK SYSTEM, POWER: (Incl w/ZQ2 Convenience Group)
	EMISSIONS: (MUST SPECIFY) (Refer Emission Requirements Tab Section)
FE9	Federal Emission Requirements
NG1	Connecticut, District of Columbia, Delaware, Massachusetts, Maryland, New Hampshire, New Jersey, New York, Pennsylvania, Rhode Island or Virginia Emission Requirements w/C5M w/o C5M
YF5	California Emission Requirements
NB8	CA, CT, DC, DE, MA, MD, NH, NJ, NY, PA, RI or VA Emission Override (Reqs FE9 Emissions)
NC7	Federal Emission Override (Reqs YF5 or NG1 Emissions)
AJ1	GLASS, DEEP TINTED: (Reqs ZW2, ZW3 or ZW6 Glass) w/ZW2 w/ZW3 w/ZW6
	GLASS ARRANGEMENTS:
ZW2	Rear Panel Doors (N/A w/E54 Dutch Doors, ZW3 or ZW6 Glass)
ZW3	Sliding Door and Rear Doors (N/A ZW2 or ZW6 Glass)
ZW6	Complete Body (N/A ZW2 or ZW3 Glass)
	GLASS, SWING-OUT
A18	Rear Doors and Side Door (Reqs ZW3 or ZW6 Glass) (N/A E54 Dutch Doors)
A19	Side Door (Reqs E54 Dutch Doors)
TL1	GRILLE: Uplevel w/Chrome Accents & Composite Headlamps (Incls Body Colored Painted Bumpers)
	GVWR RATINGS: (MUST SPECIFY)
C5G	5600 Lbs. (CM11005 Only)
C7X	5850 Lbs. (CL11005 Only)
C36	HEATER: Rear
C95	LAMPS: Dome and Reading
AU0	LOCK: Keyless Remote (Reqs AU3 Power Door Locks or ZQ2 Convenience Group)
B74	MOLDING: Body-Side
ZY1	PAINT, EXTERIOR: Solid (Refer Color/Trim Chart)

ASTRO CARGO VAN

ADDITIONAL OPTIONS

	RADIO EQUIPMENT: (Electronically Tuned AM/FM Stereo Radio w/Seek-Scan and Digital Clock) Standard
UM6	Electronically Tuned AM/FM Stereo Radio w/Seek-Scan, Digital Clock and Cassette Tape
UL0	Electronically Tuned AM/FM Stereo Radio w/Seek-Scan, Digital Clock, Automatic Tone Control, Cassette Tape, Theft Lock and Speed Compensated Volume (Reqs ZQ2 Conv. Group)
UN0	Electronically Tuned AM/FM Stereo Radio w/Seek-Scan, Digital Clock, Automatic Tone Control, Compact Disc Player, Theft Lock and Speed Compensated Volume (Reqs ZQ2 Conv. Group)
UP0	Electronically Tuned AM/FM Stereo Radio w/Seek-Scan, Digital Clock, Automatic Tone Control, Stereo Cassette Tape w/Search and Repeat, Compact Disc Player, Theft Lock and Speed Compensated Volume (Reqs ZQ2 Conv. Group)
UL5	Radio Delete
AV5	SEAT: (MUST SPECIFY) High Back Buckets
AN0	SEAT PACKAGE: Inboard/Outboard Armrest, Map Pocket, Manually Adjustable Lumbar Support (Avail w/Cloth Seats Only)
	TIRES: All Season Steel Belted Radial (Incls Front, Rear and Compact Spare) (B/W=Blackwall, WOL=White Outlined Lettered)
QCU	P215/75R-15 B/W
QCM	P215/75R-15 WOL
Z82	TRAILERING SPECIAL EQUIPMENT: Heavy-Duty (Incls Platform Trailer Hitch and 8-Lead Wiring Harness)
	WHEELS:
PA6	Styled, Steel, Painted Silver
PC2	Styled, Steel (Chrome-Cladded)

ASTRO CARGO

AVAILABLE WINDOW ARRANGEMENTS

(See Option Section for Restrictions)

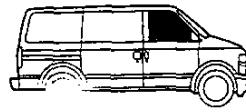
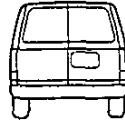
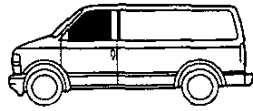

STANDARD

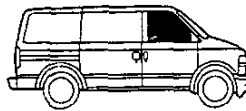
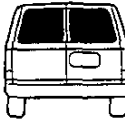
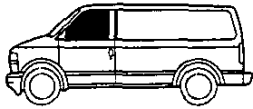

W/ZW2
(Includes Rear Door Windows)

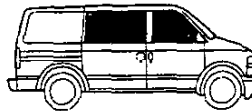
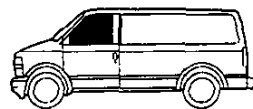

W/ZW3
(Includes Rear Door Windows
and Side Cargo Door Window)

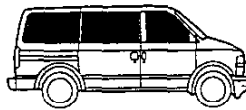
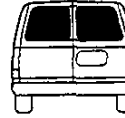

W/ZW6
(Includes Rear Door Window,
Side Cargo Door Window, RH
Rear Quarter Window & LH
Front & Rear Quarter Windows)

AVAILABLE SEATING ARRANGEMENTS

(See Interior and Exterior Chart for Restrictions)

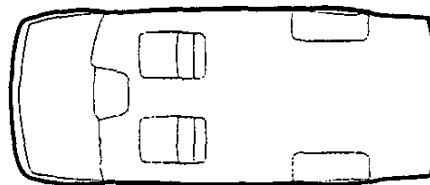

STANDARD

ASTRO CARGO VAN

INTERIOR AND EXTERIOR COLOR AVAILABILITY CHART WITH ZY1 PAINT

PLEASE NOTE: Below are the interior trim color and exterior paint combinations *recommended* by Chevrolet. They are the only available interior and exterior combinations allowed

TRIM LEVEL		SEAT OPT	Interior Colors			
(Must Specify Seat Option and Interior Color)			Med Gray	Blue	Neutral	Red
N.C. Custom Vinyl High Back Bucket Seats		AV5	92W	26W	52W	79W
N.C. Custom Cloth High Back Bucket Seats		AV5	92G	26G	52G	79G
EXTERIOR COLORS		Color Code 1	Paint Scheme	Interior & Exterior Combinations <small>Shown are the only Combinations Available</small>		
PUMPKINWOOD, LT (Met)		55U	ZY1			
BLUE, MED CADET (Met)		25U	ZY1	X	X	X
BLUE, TEAL (Met)		36U	ZY1	X		X
BRONZEMIST, MED. (Met)		76U	ZY1	X		X
COPPER, DK (Met)		69U	ZY1	X		X
GRAY, CHARCOAL, MED (Met)		14U	ZY1	X	X	X
GREEN, DK FOREST (Met)		57U	ZY1	X		X
RED, LT CARMINE (Met)		53U	ZY1	X		X
SILVERMIST (Met)		17U	ZY1	X	X	
WHITE, IVORY		10U	ZY1	X	X	X

**F7 UPFITTER PACKAGE
STRO CARGO VAN**

**INTERIOR AND EXTERIOR COLOR AVAILABILITY CHART
WITH ZY2 TWO-TONE APPEARANCE - (a) REQUIRES CLADDING**

PLEASE NOTE: Below are the interior trim color and exterior paint combinations recommended by Chevrolet. They are the only available interior and exterior combinations allowed

TRIM LEVEL				Interior Colors			
				Med Gray	Blue	Neutral	Red
TEMPORARY DRIVER'S SEAT				92W	26W	52W	79W
EXTERIOR COLORS	Color Code 1	(b)Color Code 2	Paint Scheme	Interior & Exterior Combinations Shown are the only Combinations Available			
AUTUMWOOD, LT (Met)/Bronzemist, Med. (Met)	55U	76Q	ZY2			X	
AUTUMWOOD, LT (Met)/Silvermist (Met)	55U	17Q	ZY2			X	
BLUE, MED CADET (Met)/Bronzemist, Med. (Met)	25U	76Q	ZY2			X	
BLUE, MED CADET (Met)/Autumwood, Lt (Met)	25U	55Q	ZY2		X	X	
BLUE, MED CADET (Met)/Silvermist (Met)	25U	17Q	ZY2	X	X		
BLUE, TEAL (Met)/Bronzemist, Med. (Met)	36U	76Q	ZY2			X	
BLUE, TEAL (Met)/Autumwood, Lt (Met)	36U	55Q	ZY2			X	
BLUE, TEAL (Met)/Silvermist (Met)	36U	17Q	ZY2	X			
BRONZEMIST, MED. (Met)/Autumwood, Lt (Met)	76U	55Q	ZY2			X	
COPPER, DK (Met)/Bronzemist, Med. (Met)	69U	76Q	ZY2			X	
COPPER, DK (Met)/Autumwood, Lt (Met)	69U	55Q	ZY2			X	
COPPER, DK (Met)/Silvermist (Met)	69U	17Q	ZY2	X			
GRAY, MED. CHARCOAL (Met)/Bronzemist, Med(Met)	14U	76Q	ZY2	X		X	
GRAY, MED. CHARCOAL (Met)/Autumwood, Lt (Met)	14U	55Q	ZY2			X	
GRAY, MED. CHARCOAL (Met)/Silvermist (Met)	14U	17Q	ZY2	X	X	X	
GREEN, DK FOREST (Met)/Autumwood, Lt (Met)	57U	55Q	ZY2			X	
GREEN, DK FOREST (Met)/Silvermist (Met)	57U	17Q	ZY2	X			
RED, LT CARMINE (Met)/Bronzemist, Med. (Met)	53U	76Q	ZY2			X	
RED, LT CARMINE (Met)/Autumwood, Lt (Met)	53U	55Q	ZY2			X	
RED, LT CARMINE (Met)/Silvermist (Met)	53U	17Q	ZY2	X			
WHITE, IVORY/Bronzemist, Med. (Met)	10U	76Q	ZY2			X	
WHITE, IVORY/Autumwood, Lt (Met)	10U	55Q	ZY2			X	
WHITE, IVORY/Silvermist (Met)	10U	17Q	ZY2	X	X		X

(a) Must Specify BX2 Cladding

(b) Color Code 2 Must Be Ordered as a (+) Plus Option

**YF7 UPFITTER PACKAGE
ASTRO CARGO VAN**

INTERIOR AND EXTERIOR COLOR AVAILABILITY CHART

PLEASE NOTE: Below are the interior trim color and exterior paint combinations *recommended* by Chevrolet. They are the only available interior and exterior combinations allowed

ZY1 PAINT WITHOUT BX2 CLADDING (N/A W/BVE RUNNING BOARDS)

TRIM LEVEL			Interior Colors			
			Med Gray	Blue	Neutral	Red
TEMPORARY DRIVER'S SEAT			92W	26W	52W	79W
EXTERIOR COLORS W/ZY1 PAINT APPLICATION	Color Code 1	Paint Scheme	Interior & Exterior Combinations Shown are the only Combinations Available			
AUTUMWOOD, LT (Met)	55U	ZY1			X	
BLUE, MED CADET (Met)	25U	ZY1	X	X	X	
BLUE, TEAL (Met)	36U	ZY1	X		X	
BRONZEMIST, MED (Met)	76U	ZY1	X		X	
COPPER, DK (Met)	69U	ZY1	X		X	
GRAY, MED CHARCOAL (Met)	14U	ZY1	X	X	X	
GREEN, DK FOREST (Met)	57U	ZY1	X		X	
RED, LT CARMINE (Met)	53U	ZY1	X		X	
SILVERMIST (Met)	17U	ZY1	X	X		X
WHITE, IVORY	10U	ZY1	X	X	X	X

ZY1 PAINT WITH BX2 CLADDING

TRIM LEVEL			Interior Colors			
			Med Gray	Blue	Neutral	Red
TEMPORARY DRIVER'S SEAT			92W	26W	52W	79W
EXTERIOR COLORS W/ZY1 PAINT APPLICATION	Color Code 1	(a)Paint Scheme	Interior & Exterior Combinations Shown are the only Combinations Available			
AUTUMWOOD, LT (Met)	55U	ZY1			X	
BLUE, TEAL (Met)	36U	ZY1	X		X	
BRONZEMIST, MED (Met)	76U	ZY1	X		X	
COPPER, DK (Met)	69U	ZY1	X		X	
SILVERMIST (Met)	17U	ZY1	X	X		X
WHITE, IVORY	10U	ZY1	X	X	X	X

(a)Must Specify BX2 Cladding

**YF7 UPFITTER PACKAGE
ASTRO CARGO VAN**

ADDITIONAL OPTIONS

- D48 **MIRRORS:** Below-Eye-Line, Electric Remote, Painted (Incl w/1SP/1SR)
w/1SN
PAINT, EXTERIOR: (Refer Color/Trim Chart for Availability)
- ZY1 Solid
- ZY2 Two-Tone Appearance (Reqs BX2 Cladding)
- RADIO EQUIPMENT:** (Electronically Tuned AM/FM Stereo Radio w/Cassette & Digital Clock Inc w/YF7)
- UL0 Electronically Tuned AM/FM Stereo Radio w/Seek-Scan, Digital Clock, Automatic Tone Control,
Cassette Tape, Theft Lock and Speed Compensated Volume
w/1SR
w/1SN or 1SP
- UN0 Electronically Tuned AM/FM Stereo Radio w/Seek-Scan, Digital Clock, Automatic Tone Control,
Compact Disc Player, Theft Lock and Speed Compensated Volume
w/1SR
w/1SN or 1SP
- UP0 Electronically Tuned AM/FM Stereo Radio w/Seek-Scan, Digital Clock, Automatic Tone Control,
Stereo Cassette Tape w/Search and Repeat, Compact Disc Player, Theft Lock and Speed
Compensated Volume
w/1SR
w/1SN or 1SP
- BVE **RUNNING BOARDS:** (Reqs BX2 Cladding)
- SEAT, POWER:**
- AG1 6-Way, Driver's side only (w/Temporary Seat)
- AG2 6-Way, Passenger (Reqs AG1 Seat) (Risers Only -- No Seat)
- NP5 **STEERING WHEEL:** Black Leather-Wrapped
w/1SP or 1SR
w/1SN
- FE2 **SUSPENSION SYSTEM:** Ride Handling (CM11005 Only) (Incls Front and Rear Gas Shock Absorbers,
Rear Stabilizer Shaft and P235/65R-15 WOL Tires) (Incls 14:1 Ratio Power Assist Steering)
TIRES: All Season Steel Belted Radial (Incls Front, Rear and Compact Spare)
(B/W=Blackwall, WOL=White Outlined Lettered)
- QCU P215/75R-15 B/W
- QCM P215/75R-15 WOL
- Z82 **TRAILERING SPECIAL EQUIPMENT:** Heavy-Duty (Incls Platform Trailer Hitch and 8-Lead Wiring Harness)
- UG1 **TRANSMITTER, HOMELINK® 3-CHANNEL GARAGE DOOR:** (Reqs DK8 Roof Console)
- WHEELS:**
- PA6 Styled, Steel, Painted Silver
- PF3 Aluminum, Brushed
w/1SR
w/1SN or 1SP
- PC2 Styled Steel (Chrome Cladded)
w/1SR
w/1SN or 1SP

**YF7 UPFITTER PACKAGE
ASTRO CARGO VAN**

ADDITIONAL OPTIONS

	ACKNOWLEDGMENTS:
R8S	Multiple Order Numbers
R8T	Preliminary Invoice
	AXLE, REAR: (MUST SPECIFY)
GU5	3.23 Ratio (CM11005 Only)
GU6	3.42 Ratio
GT4	3.73 Ratio
G80	Locking Differential
	BODY CODE:
ZW9	Standard Body Equipment
E54	Dutch Doors (Incls Wiper/Washer and Electric Release) w/1SP or 1SR w/1SN
V54	CARRIER: LUGGAGE: Painted Black
BX2	CLADDING: Lower Body Side (Required w/ZY2)
V10	COLD CLIMATE PACKAGE: (Incls Engine Block Heater and Coolant Protection)
DK8	CONSOLE, INTERIOR ROOF: (Incls Illuminated Visor Mirror, Compass, Outside Temperature and Trip)
C49	DEFOGGER: Rear Window Electric (Reqs E54 Body) EMISSIONS: (MUST SPECIFY) (Refer Emission Requirements Tab Section)
FE9	Federal Emission Requirements
NG1	Connecticut, District of Columbia, Delaware, Massachusetts, Maryland, New Hampshire, New Jersey, New York, Pennsylvania, Rhode Island or Virginia Emission Requirements w/C5M w/o C5M
YF5	California Emission Requirements
NB8	CA, CT, DC, DE, MA, MD, NH, NJ, NY, PA, RI or VA Emission Override (Reqs FE9 Emissions)
NC7	Federal Emission Override (Reqs YF5 or NG1 Emissions)
ZW6	GLASS ARRANGEMENT: Complete Body
AJ1	GLASS, DEEP TINTED: w/ ZW3 & 1SP or 1SR w/ZW3 & 1SN w/ZW6 & 1SP or 1SR w/ZW6 & 1SN
	GLASS, SWING-OUT
A18	Rear Doors and Side Door (N/A E54 Dutch Doors) w/1SP or 1SR w/1SN
A19	Side Door (Reqs E54 Dutch Doors) w/1SP or 1SR w/1SN
	GVWR RATINGS: (MUST SPECIFY)
C5M	6100 Lbs. (CL11005 Only)
C6M	5950 Lbs. (CM11005 Only)
C36	HEATER: Rear
C95	LAMPS: Dome and Reading (N/A w/DK8 Interior Roof Console)
AU0	LOCK: Keyless Remote w/1SN or 1SP w/1SR

**YF7 UPFITTER PACKAGE
ASTRO CARGO VAN**

YF7 UPFITTER PACKAGE INCLUDES:

Convenience Package: Tilt-Wheel and Speed Control
 Glass: Sliding Door and Rear Panel Doors (May Substitute ZW6 Glass)
 Grille: Uplevel w/Chrome Accents, Composite Headlamps and Painted Body-Colored Front & Rear Bumpers
 Radio: Electronically Tuned AM/FM Stereo w/Seek-Scan, Cassette Tape and Digital
 Clock (May Substitute UL0, UN0 or UP0 Radio)
 Air Conditioning w/Rear Quick Connect Fittings
 B-Pillar Electrical Connections
 Color-Keyed Front Headliner
 Front Underseat Floor Ducts
 Generator, 105 AMP
 Incomplete Vehicle Certification
 Mirrors: Black, Below-Eye-Line (May substitute D48 Mirrors)
 Rear Heater Switch and Wiring
 Rear Shoulder Belt Anchors
 Temporary Driver's Seat with LH and RH Belts and Risers (VK5)
 Wiring Harness for Dome Lamps
 Visor, Mirror
 Power Windows and Power Locks

NO DELETIONS ALLOWED. ADDITIONAL OPTIONS/UPGRADES (WHERE INDICATED)
 MAY BE ORDERED FROM THE ADDITIONAL OPTION LISTING

		YF7 PEGS		
		1SN	1SP	1SR
Upfitter Preferred Equipment Group				
Upfitter Package	YF7	X	X	X
Body (Standard) (May Substitute E54 Dutch Doors)	ZW9	X	X	X
Styled Steel (Painted Silver) (a)	PA6	X	X	N/I
Upfitter Preferred Equipment Group Savings				
Glass, Swing-out (w/E54 Incis A19 Glass)	A18		X	X
Steering Wheel: Black Leather Wrapped	NP5		X	X
Deep Tinted Glass	AJ1		X	X
Painted Electric Remote Mirrors	D48		X	X
Upfitter Preferred Equipment Group Savings				
Lock, Keyless Remote	AU0			X
Radio, AM/FM Stereo Cassette w/Auto. Tone Ctrl	UL0			X
Wheels, Brushed Aluminum (b)	PF3			X

Allowable Substitutions (Where Available):

- (a) PA6: May Substitute PF3 or PC2 Wheels
- (b) PF3: May Substitute PC2 Wheels

Note: For information purposes only YF7 Upfitter Package available for ordering through authorized C.Q.A.C.P. Manufacturer's Only

YF7 UPFITTER PACKAGE ASTRO CARGO VAN

MODEL AND BODY

Description	Model No.	Body	Wheelbase
Rear-Wheel Drive Model			
Astro Van	CM11005	ZW9	111.2"

Description	Model No.	Body	Wheelbase
All-Wheel Drive Model			
Astro Van	CL11005	ZW9	111.2"

GVWR SELECTOR (MUST SPECIFY)

GVW RATING (LBS.)	Minimum Equipment Required for GVW Rating			Restrictions
	(a) GAWR (LBS.)			
	Front	Rear		
C6M	5950	2800	3150	CM11005 Only
C5M	6100	3050	3150	CL11005 Only

(a) GAWR's shown are the minimum for each axle with equipment listed. Other GAWR's are available and they are determined as the minimum capacity of either axle or springs or tires.

CAPACITIES

CM11005			CL11005		
SPRINGS:	AXLES:		SPRINGS:	AXLES:	
FRONT	FRONT		FRONT	FRONT	
2800 Base	2800 Base	2800 Base	3050 Base	3050 Base	3050 Base
REAR	REAR		REAR	REAR	
3150 Base	3150 Base	3150 Base	3150 Base	3150 Base	3150 Base

POWER TEAMS (Must Specify Engine, Transmission and Rear Axle)

(Consult GVWR Selector for Minimum Equipment Required)

ENGINE	TRANSMISSION	AXLES			GVWR
	(Auto)	3.23	3.42	3.73	
CM11005					
L35 Vortec 4300 SFI V6	M30	GU5	GU6	GT4	5950
CL11005					
L35 Vortec 4300 SFI V6	M30	—	GU6	GT4	6100

M/L ASTRO CARGO VAN INTRODUCTION

M/L ASTRO CARGO VAN

The M/L Astro Cargo Van is offered only in the standard trim level.

Changes on the Astro Cargo Van for 1999 include:

- 4L60-E Automatic Transmission Enhancements (M30)
- Replacing Current Key Heads with Larger Key Heads that will include Brand Logo
- New Active Transfer Case on Model L11005 which offers "State-of-the-Art" All-Wheel-Drive Technology
- New Improvements to the DK8 Roof Console Include a Trip Computer, Average Fuel Economy, Instantaneous Fuel Economy, Trip Range, Fuel Used and Elapsed Time in Addition to Outside Temperature and Compass
- Two New Exterior Colors

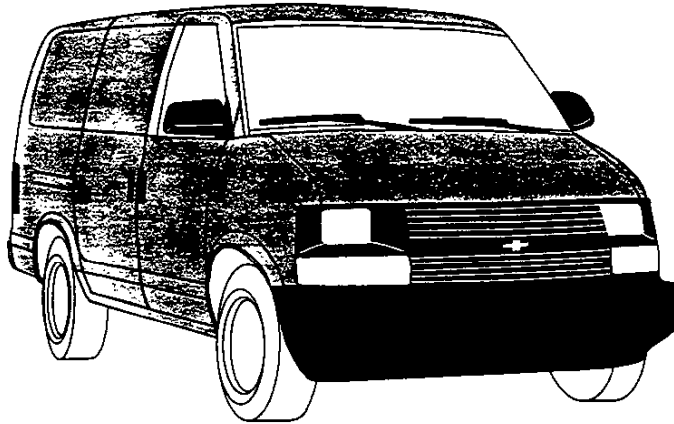

M/L ASTRO CARGO VAN

MODEL SELECTION SUMMARY

Use the chart below to choose the model that fits your customer's needs. Please note that the Base Payloads shown reflect the maximum allowable weight of cargo that can be carried in a standard model, including occupants. (They are calculated by subtracting curb weight from GVWR.) To calculate payloads for models with optional equipment, please refer to the WEIGHTS section in the back of this book or consult your 1999 GM PROSPEC. Also, the Maximum Trailer Weights shown on the last page of this section are based on vehicles that are properly equipped. See your Chevrolet Truck Order Guide for specific details.

SERIES	MODEL NUMBER/ BODY CODE/ OPTION CODE	PASSENGER CAPACITY (STD./OPT.)	STANDARD ENGINE/ TRANS.	OPTIONAL ENGINE/ TRANS.	GVWR (LB)	GAWR (LB) FRONT/ REAR	BASE PAYLOAD (LB)
REAR-WHEEL-DRIVE MODEL							
ASTRO CARGO VAN	CM11005/ZW9	2/-	4300 V6/A4	—	5600	2800/3150	1713
ALL-WHEEL-DRIVE MODEL							
ASTRO ALL-WHEEL-DRIVE CARGO VAN	CL11005/ZW9	2/-	4300 V6/A4	—	5850	3050/3150	1715

POWERTRAIN

Chevrolet offers a variety of rear axle ratios for the M/L Astro Cargo Van. The following charts detail basic engine, transmission and axle specifications. See your 1999 Chevrolet Truck Order Guide for specific details.

ENGINE	
VORTEC 4300 V6	
Order Code	L35
SAE Net Horsepower @ rpm	190 @ 4400
SAE Net Torque lb-ft @ rpm	250 @ 2800
Fuel System	SFI
Standard Battery Cold Cranking Amps @ 0° F	600
Standard Alternator Maximum Capacity (Amps)	100

TRANSMISSION	
ELECTRONIC AUTOMATIC 4-SPEED W/OVERDRIVE AND TORQUE CONVERTER CLUTCH (4L60-E)	
Order Code	M30
Gear Ratios	
First	3.06
Second	1.63
Third	1.00
Fourth	0.70
Reverse	2.29

AXLES					
	REAR AXLE			FRONT AXLE (ALL-WHEEL-DRIVE MODEL ONLY)	
	Make	GM			GM
Capacity (lb)	3150			3050	
Pinion and Ring Gear Type	Hypoid			Hypoid	
Axle Ratio Code	GU5	GU6	GT4	GU6	GT4
Ratio	3.23	3.42	3.73	3.42	3.73
Pinion Teeth	13	12	11	12	11
Ring Gear Teeth	42	41	41	41	41
Ring Gear Diameter (in.)	7.625	7.625	7.625	7.25	7.25

Note: Axle ratio depends on model, powertrain and emissions selected.

M/L ASTRO CARGO VAN

TRIM LEVELS

Chevrolet offers the M/L Astro Cargo Van in one trim level: "Standard." The following chart details major features. See your 1999 Chevrolet Truck Order Guide for details.

CHASSIS EQUIPMENT		
KEY: ■ = STANDARD, — = NOT INCLUDED		STANDARD (ZW9)
BRAKES	Power-assisted front disc, rear drum; with four-wheel anti-lock system. Includes brake/transmission shift interlock.	■
EXHAUST	Single with aluminized stainless steel tailpipe and muffler.	■
FRAME	Integral body design with boxed section front stub frame.	■
FUEL TANK	25-gallon (approx.) capacity.	■
REAR AXLE	Hypoid, semi-floating.	■
SHOCK ABSORBERS	Front: 32mm; Rear: 32mm.	■
STABILIZER BAR	Front: M Vans 1.10 inch; L Vans 1.18 inch.	■
STEERING	Variable Power Assist.	■
SUSPENSION, FRONT	4x2: Independent w/coil springs. All-wheel drive: Independent w/torsion bars.	■
SUSPENSION, REAR	Steel leaf springs.	■
EXTERIOR EQUIPMENT		
BUMPERS	Front molded-gray. Rear-painted gray with gray step pad.	■
DOORS	Driver and passenger front side, sliding RH side door and RH/LH rear load doors.	■
GRILLE	Molded, composite; painted argent.	■
HEADLAMPS	Single sealed-beam halogen.	■
HORN	Dual high-note and low-note.	■
LAMP	Center high-mounted stoplamp.	■
LICENSE PLATE MOUNTING (FRONT)	Molded in fascia.	■
MIRRORS	Below-eyeline type, black; LH: 5.0" x 8.5", RH: 5.25" x 9.0".	■
SPARE TIRE CARRIER	Winch-type mounted under floor at rear.	■
SPARE TIRE/WHEEL	Compact; mounted under floor at rear.	■
TIRES	Four P215/75R15, all-season steel-belted radial blackwall.	■
WHEELS	Four 15.0" x 6.0" argent steel wheels. Bright metal center caps with black trim.	■
WIRING	Six-wire harness for trailering purposes. (Includes CHMSL)	■
INTERIOR EQUIPMENT		
AIR CONDITIONING	Front.	■
ARMRESTS	RH/LH front door.	■
ASSIST HANDLES	Front at RH "A-pillar."	■
CIGARETTE LIGHTER	Includes ashtray lamp.	■
COAT HOOK	Left-hand side.	■
DOOR STEPWELL	Black.	■
DOORS	Side-door guard beams for front side doors and sliding side door. Sliding door includes child safety lock.	■
DOOR TRIM	Color-keyed expanded vinyl on driver's and passenger door with armrests, map pockets, radio speakers and door reflectors.	■
FLOOR COVERING	Embossed front black rubber mat.	■
GAUGES	Coolant temperature, fuel level, odometer, oil pressure, speedometer, trip odometer and voltmeter.	■
GLOVE BOX	Located in front face of engine cover extension. Includes two beverage holders on top of engine cover extension.	■
HEADLAMP WARNING TONE	Headlamps on.	■
HEADLINER	Front compartment, color-keyed, foam-backed cloth.	■
HEATER	Includes windshield and side-window defoggers.	■
LAMPS	Stepwell lamps, storage compartment lamp and three dome lamps with front, rear and sliding door-activated switches (also includes delayed illuminated entry system). Includes door jamb override button.	■
MAP NET	Storage pouch located on passenger side of engine cover extension.	■
MIRROR	10-inch rearview.	■
POWER OUTLETS	Two covered electrical accessory outlets located on the passenger side of the engine cover extension. (In addition to cigarette lighter.)	■
RADIO	Electronically tuned AM/FM stereo radio with seek-scan, digital clock, two front-door speakers and fixed-mast antenna.	■

M/L ASTRO CARGO VAN

INTERIOR EQUIPMENT (CONT.)

KEY: ■ = STANDARD, — = NOT INCLUDED		STANDARD (ZW9)
SEATS, FRONT	Two high-back vinyl reclining bucket seats. Adjust fore and aft.	■
SECURITY	PassLock® theft deterrent system.	■
STEERING WHEEL	Black vinyl 4-spoke with anti-theft locking feature.	■
SUNSHADES	Color-keyed vinyl RH and LH padded sunshades with map bands.	■
TOOLS	Screw-operated scissor-type jack with ratchet handle and extension and two wheel blocks. Located at right rear.	■
WINDOWS	Solar-Ray® tinted glass.	■
WINDSHIELD WIPERS	Intermittent.	■

SAFETY EQUIPMENT

AIR BAGS*	Driver and front seat passenger (next generation).	■
BRAKES	4-wheel anti-lock.	■
DOOR BEAMS	Side-door guard beams for front side doors and sliding side door. Sliding door includes child safety lock.	■
LAMPS	Daytime running lamps/center high-mounted stoplamp (CHMSL).	■
SEAT BELTS	Lap and shoulder.	■
STEERING COLUMN	Energy-absorbing (also includes anti-theft locking).	■

*Always wear your safety belts.

PREFERRED EQUIPMENT GROUPS

Preferred Equipment Groups (PEGs) are convenient option packages that can save your customers money. They would pay appreciably more by buying all the options in a Preferred Equipment Group as individual options. (Savings based on a comparison of Manufacturer's Suggested Retail Price of option packages versus MSRP of individual options purchased separately). See your 1999 Chevrolet Truck Order Guide and Vehicle Price Schedule for specific information and prices.

OPTIONS

These options can be ordered individually in addition to the Preferred Equipment Groups if not already included. See your 1999 Chevrolet Truck Order Guide for specific availability and restrictions. The Option Code is listed in **bold type**.

Air Conditioning (not desired)	YG6
Axles, Rear	
3.23	GU5
3.42	GU6
3.73	GT4
Locking Differential	G80
Body Code	
Standard Body Equipment	ZW9
Dutch Doors (includes electric release and intermittent wiper/washer) (reqs. power door locks)	E54
Cladding (YF7 only)	BX2
Cold Climate Package (includes engine block heater, coolant protection)	V10
Convenience Groups	
Power Door Locks and Power Windows	ZQ2
Tilt-Wheel™ Steering and Electronic Speed Control	ZQ3
Defroster, Rear Window (requires E54 dutch doors)	C49
Door Locking System, Power	AU3
Emissions	
Federal	FE9
California	YF5
Massachusetts/New York/Connecticut/Rhode Island/New Jersey	NG1
CA/MA/NY/CT/RI/NJ Emissions Override	NB8
Federal Emissions Override	NC7
Engine	
VORTEC 4300 SFI V6	L35

Glass Arrangements	
Complete Body	ZW6
Rear Panel Doors, Solar-Ray®	ZW2
Sliding Door and Rear Panel Doors, Solar-Ray®	ZW3
Swingout Rear Doors and Side-Door Solar-Ray® (except with E54 which includes swingout side-door glass only)	A18
Sliding Side Door, Solar-Ray®	A19
Deep-Tinted, Solar-Ray®	AJ1
Grille, Deluxe Appearance with Bright Inserts; Includes Composite Headlamps and Body-Color Bumpers	TL1
GVWR	
5600-lb	C5G
5850-lb	C7X
Heater, Rear	C36
Lamps, Dual Reading	C95
Lock, Keyless Remote (requires AU3 Power Door Locks or ZQ2 Convenience Group)	AU0
Molding, Bodyside	B74
Paint Exterior, Solid	ZY1
Radio Equipment	
Radio Delete	UL5
ETR AM/FM Stereo Radio w/Seek-Scan, Digital Clock, Stereo Cassette and two front door speakers	UM6
ETR AM/FM Stereo Radio w/Seek-Scan, Automatic Tone Control, Cassette Tape, Digital Clock, Theft Lock™, Speed-Compensated Volume and Two Front-Door Speakers	

& Two Tweeters with Rear Speaker Wiring (reqs ZQ2)	UL0
ETR AM/FM Stereo Radio w/Seek-Scan, Automatic Tone Control, Compact Disc Player, Digital Clock, Theft Lock™, Speed-Compensated Volume and Two Front-Door Speakers & Two Tweeters with Rear Speaker Wiring (reqs ZQ2)	UN0
ETR AM/FM Stereo Radio w/Seek-Scan, Automatic Tone Control, Cassette Tape, Compact Disc Player, Digital Clock, Theft Lock™, Speed-Compensated Volume and Two Front-Door Speakers & Two Tweeters with Rear Speaker Wiring (reqs ZQ2)	UP0
Recreational Sales Package, Vehicle Upfitter (For information purposes only. YF7 is available for ordering through authorized CQACP manufacturers only.)	YF7
Seat Package (Includes inboard and outboard armrests and map pockets. Manual lumbar support is also included when cloth seats are ordered.)	AN0
Trailer Package, Heavy-Duty (includes hitch platform and eight-wire harness)	ZB2
Transmission, 4-Speed Electronically Controlled Automatic w/Overdrive	M30
Wheels	
Styled Steel (painted sparke silver)....	PA6
Styled Steel (chrome clad)	PC2

M/L ASTRO CARGO VAN

TIRES

KEY: ALS = ALL-SEASON SBR = STEEL-BELTED RADIAL PLY BW = BLACKWALL WOL = WHITE OUTLINED LETTERED WS = WHITE STRIPE

TIRE DESCRIPTION		ORDERING CODE
P215/75R15	ALS/SBR/BW	QCU
P215/75R15	ALS/SBR/WOL	QCM

DIMENSIONS

MODEL	ASTRO CARGO VAN	ASTRO ALL-WHEEL-DRIVE CARGO VAN
MODEL NUMBER	CM11005/ZW9	CL11005/ZW9
EXTERIOR DIMENSIONS		
BODY		
Wheelbase (in.) L101	111.2	111.2
Overall Length (in.) L103	189.8	189.8
Overall Height (in.) Nominal H431	75.3	75.2
Maximum Width (in.) W103	77.5	77.5
Bumper to Axle (in.) Front L104	32.5	32.5
Rear L105	46.0	46.0
Ground to Top of Rear Load Floor (in.) H502	26.7	26.6
Ground Clearance (in.) Front/Rear H148/H153	6.8/7.4	6.8/7.4
Side Load Door		
Opening Height (in.) H505	46.8	46.8
Opening Width (in.) L508	34.5	34.5
Rear Load Door		
Opening Height (in.) H202	42.0	42.0
Opening Width (in.) W204	57.2	57.2
Step-Up Height (in.)* Front Door H130	18.9	18.8
Side Load Door H131	20.7	20.6
Turning Diameter Curb-to-Curb (ft)	42.7	42.2
Track Width (in.) Front/Rear W101/102	65.1/65.1	65.1/65.1
SIGN PANEL AREA (in.)		
Side Panel (in.)	46 x 88	46 x 88
Front Door (in.)	18 x 40	18 x 40

* Height from ground level to the surface of the stepwell.

INTERIOR DIMENSIONS

Headroom (in.) H61	39.2	39.2
Legroom (in.) L34	41.6	41.6
Shoulder Room (in.) W3	64.0	64.0
Hip Room (in.) W5	65.0	65.0
Load Floor Length (in.) to Console L512	126.0	126.0
w/Front Seat L202	98.6	98.6
Interior Height (in.) H201	47.2	47.2
Interior Width (in.) Between Wheelhousings W201	51.6	51.6
Cargo Volume (cu ft)	170.4	170.4

M/L ASTRO CARGO VAN

TRAILERING

Weight-carrying hitch limit: 2000-lb trailer with 200-lb tongue weight. Weight distributing hitch and sway control required over 2000-lb trailer weight.

ENGINE/ TRANSMISSION		VORTEC 4300 V6/ AUTOMATIC	
MAXIMUM TRAILERING			
MODEL	AXLE RATIO	MAX. TONGUE LOAD/ MAX. TRAILER WEIGHT (lb)	
2WD M-VAN	3.23	*/4500	
	3.42	*/5000	
	3.73	*/5500	
AWD L-VAN	3.42	*/4500	
	3.73	*/5000	

*Trailer tongue weight should be 10 to 15% of total loaded trailer weight (up to 750 lb).

Notes:

Maximum trailer weight is calculated assuming the driver and one passenger are in the tow vehicle and it has all required trailering equipment. The weight of additional optional equipment, passengers and cargo in the tow vehicle must be subtracted from the maximum trailer weight. Z82 heavy-duty Trailering Equipment Package includes weight-distributing hitch platform and 8-wire trailer harness. Base cooling system includes all content required to attain maximum rating. No optional cooling equipment available.