



# MANUFACTURERS MOTOR VEHICLE SPECIFICATIONS

METRIC (U.S. Customary)

# 1995

<b>Manufacturer</b> NEW UNITED MOTOR MFG., INC. (NUMMI)	<b>Vehicle Line</b>  Geo PRIZM	
<b>Mailing Address</b> GENERAL MOTORS CORPORATION CHEVROLET CENTRAL OFFICE 30007 VAN DYKE WARREN, MI 48090-9065	<b>Issued</b>  SEPTEMBER, 1994	<b>Revised</b>  

Direct questions concerning these specifications to the manufacturer listed above.

The information contained herein is prepared, distributed by, and is solely the responsibility of the vehicle manufacturing company to whose products it relates. This specification form was developed by the vehicle manufacturing companies under the auspices of the American Automobile Manufacturers Association.

The General Specifications herein are those in effect at date of compilation and are subject to change without notice or incurring obligation by the manufacturer.

## AAMA

American Automobile Manufacturers Association

Blank Forms Provided by Technical Affairs Division



# MVMA Specifications

METRIC (U.S. Customary)

## Table of Contents

---

	1	Vehicle Models/Origin	∅	Indicates Format Change From Previous Year
	2	Power Teams		
	3	Engine		
	4	Lubrication System		
	4	Diesel Information		
	5	Cooling System		
	6	Fuel System		
	7	Vehicle Emission Control		
∅	7	Exhaust System		
∅	8-10	Transmission, Axles and Shafts		
	11	Suspension		
	12-13	Brakes, Tires and Wheels		
	14	Steering		
	15-16	Electrical		
∅	17	Body - Miscellaneous Information		
	17	Frame		
	18	Restraint System		
	18	Glass		
	18	Headlamps		
	19	Climate Control System		
	20-21	Convenience Equipment		
	21	Trailer Towing		
	22-24	Vehicle Dimensions		
	25	Vehicle Fiducial Marks		
	26	Vehicle Mass (weight)		
	27	Optional Equipment Differential Mass (Weight)		
	28-34	Vehicle Dimensions Definitions - Key Sheets		
	35	Index		

---

### NOTE:

1. This form uses both SI metric units and U.S. Customary units. The metric unit of measure is presented first, and the U.S. Customary unit follows in parentheses.
2. UNLESS OTHERWISE INDICATED:
  - a. Specifications apply to standard models without optional equipment. Significant deviations are noted.
  - b. Nominal design dimensions are used throughout these specifications.
  - c. All linear dimensions are in millimeters (inches), and all mass (weight) specifications are in kilograms (pounds).
3. The General Specifications herein are those in effect at date of compilation and are subject to change without notice or incurring obligation by the manufacturer.
4. Additional Vehicle Dimensions (based in part on SAE J1100 "Motor Vehicle Dimensions") may be available from the manufacturer.



•  
•  
•



# MVMA Specifications

Vehicle Line Geo PRIZM  
 Model Year 1995 Issued 9/94 Revised (\*) \_\_\_\_\_

METRIC (U.S. Customary)

## Vehicle Origin

Design & development (company)	Toyota Motor Corporation
Where built (country)	U.S.A.
Authorized U.S. sales marketing representative	Chevrolet / Geo

## Vehicle Models

Model Description & Drive (FWD / RWD / AWD / 4WD)*	Introduction Date	Make, Vehicle Models, Series, Body Type (Mfg's Model Code)	No. of Designated Seating Positions (Front / Rear)	Max. Trunk/Cargo Load-Kilograms (Pounds)	EPA Fuel Economy (City/hwy)
Geo PRIZM 4-Door Notchback Sedan (FWD)	8/94	1SK19	5 (2/3)	45 (100)	M/T TBD A/T TBD
Geo PRIZM LSi 4-Door Notchback Sedan (FWD)	8/94	1SK19	5 (2/3)	45 (100)	M/T TBD A/T TBD

\* FWD - Front Wheel Drive RWD - Rear Wheel Drive AWD - All Wheel Drive 4WD - Four Wheel Drive



# MVMA Specifications

Vehicle Line Geo PRIZM  
 Model Year 1995 Issued 9/94 Revised (\*) \_\_\_\_\_

## METRIC (U.S. Customary)

### Power Teams

SAE J1349 Net bhp (brake horsepower) and Net Torque corrected to 77°F/25°C and 29.61 in. Hg/100 kPa atmospheric pressure.

		A	B	C	D	
ENGINE	Engine Code	L01	L01	LV6	LV6	
	Displacement Liters (in <sup>3</sup> )	1.6 (97)	1.6 (97)	1.8 (108)	1.8 (108)	
	Induction system (FI, Carb, etc.)	Multi-Port Fuel Injection	Multi-Port Fuel Injection	Multi-Port Fuel Injection	Multi-Port Fuel Injection	
	Compression ratio	9.5:1	9.5:1	9.5:1	9.5:1	
	SAE Net at RPM	Power kW (bhp)	78 (105) @ 5800	78 (015) @ 5800 **	86 (115) @ 5600	86 (115) @ 5600 **
		Torque N • m (lb. ft.)	136 (100) @ 4800	136 (100) @ 4800	156 (115) @ 2800	156 (115) @ 2800
Exhaust single, dual		Single	Single	Single	Single	
TRANS	Transmission/Transaxle	Manual Transaxle 5-Speed	Auto Transaxle 3-Speed	Manual Transaxle 5-Speed	Auto Transaxle 4-Speed	
	Effective Final Drive / Axle Ratio (std. first)	3.72	3.53	3.72	2.82	

Series Availability		Power Teams (A - B - C - D)	
Model	Code	Standard	Optional
Geo PRIZM			
4-Door Notchback Sedan	1SK19	A	B
Geo PRIZM LSi			
4-Door Notchback Sedan	1SK19	A	B,C,D





.

.

# MVMA Specifications

Vehicle Line Geo PRIZM  
 Model Year 1995 Issued 9/94 Revised (•) \_\_\_\_\_

## METRIC (U.S. Customary)

Engine Description  
 Engine Code

1.6 LITER L4 (97 CID) MULTI-PORT FUEL INJECTION RPO L01

### Engine - General

Type & description (inline, V, angle, flat, location, front, mid, rear, transverse, longitudinal, sohc, dohc, ohv, hemi, wedge, pre-chamber, etc.)	Inline, Front, Transverse, DOHC Pent Roof	
Manufacturer	Toyota Motor Corporation	
No. of cylinders	4	
Bore	81.0 mm (3.2 in.)	
Stroke	77.0 mm (3.0 in.)	
Bore Spacing (C/L to C/L)	87.5 mm (3.4 in.)	
Cylinder block material & mass kg. (lbs.) (machined)	Cast Iron, 31.3 (69.0)	
Cylinder block deck height	191.0 mm (7.5 in.)	
Cylinder block length	391.5 mm (15.4 in.)	
Deck clearance (minimum) (above or below block)	0.00 mm	
Cylinder head material & mass kg. (lbs.)	Aluminum Alloy, 11.0 (24.3)	
Cylinder head volume cm <sup>3</sup> (inches <sup>3</sup> )	33.7 (2.1)	
Cylinder liner material	Not Applicable	
Head gasket thickness (compressed)	1.20 mm (.05 in.)	
Minimum combustion chamber total volume cm <sup>3</sup> (inches <sup>3</sup> )	51.8 (3.2)	
Cyl. no. system (front to rear)*	L. Bank	1-2-3-4
	R. Bank	
Firing order	1-3-4-2	
Intake manifold material & mass kg. (lbs.)**	Aluminum Alloy, 3.5 (7.7)	
Exhaust manifold material & mass kg. (lbs.)**	Cast Iron, 4.0 (8.8)	
Knock sensor (number & location)	No	
Fuel required unleaded, diesel, etc.	Unleaded	
Fuel antiknock index (R + M) + 2	87	
Engine Mounts	Quantity	4
	Material and type (elastomeric, hydroelastic, hydraulic damper, etc.)	RH: Hydroelastic Other: Elastomeric
	Added isolation (sub-frame, crossmember, etc.)	Fr: CTR Member, RR: Sub-Frame; RH: RH Side Member; LH: LH Side Member
Total dressed engine mass (wt) dry***	M/T: 120 kg (264.6 lbs)	A/T: 112 kg (246.9 lbs)

### Engine - Pistons

Material & mass, g (weight, oz.) - piston only	Aluminum Alloy, 278 (9.8)
--	---------------------------

### Engine - Camshaft

Location	Over Cylinder Head	
Material & mass kg (weight, lbs.)	Gray Cast Iron, Intake = 1.9 (.419) Exhaust = 2.1 (.462)	
Drive type	Chain / belt	Belt
	Width / pitch	8.0 / 21.1 mm (.31 / .831 in.)

\* Rear of engine - drive takeoff. View from drive takeoff end to determine left & right side of engine.

\*\* Finished state.

\*\*\* Dressed engine mass (weight) includes the following: All those items necessary to make the engine a complete ready-to-run unit.

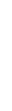

# MVMA Specifications

Vehicle Line Geo PRIZM  
 Model Year 1995 Issued 9/94 Revised (●) \_\_\_\_\_

## METRIC (U.S. Customary)

Engine Description  
 Engine Code

1.8 LITER L4 (108 CID) MULTI-PORT FUEL INJECTION RPO LV6

### Engine - General

Type & description (inline, V, angle, flat, location, front, mid, rear, transverse, longitudinal, sohc, dohc, ohv, hemi, wedge, pre-chamber, etc.)	Inline, Front, Transverse, DOHC Port Fuel	
Manufacturer	Toyota Motor Corporation	
No. of cylinders	4	
Bore	81.0 mm (3.2 in.)	
Stroke	85.5 mm (3.4 in.)	
Bore Spacing (C/L to C/L)	87.5 mm (3.4 in.)	
Cylinder block material & mass kg. (lbs.) (machined)	Cast Iron, 33.0 (72.8)	
Cylinder block deck height	206.4 mm (8.1 in.)	
Cylinder block length	391.5 mm (15.4 in.)	
Deck clearance (minimum) (above or below block)	0.00 mm	
Cylinder head material & mass kg. (lbs.)	Aluminum Alloy, 11.0 (24.3)	
Cylinder head volume cm <sup>3</sup> (inches <sup>3</sup> )	33.7 (2.1)	
Cylinder liner material	Not Applicable	
Head gasket thickness (compressed)	.56 mm (0.22 in.)	
Minimum combustion chamber total volume cm <sup>3</sup> (inches <sup>3</sup> )	46.6 (2.8)	
Cyl. no. system (front to rear)*	L. Bank	1-2-3-4
	R. Bank	
Firing order	1-3-4-2	
Intake manifold material & mass kg. (lbs.)**	Aluminum Alloy, 3.1 (6.8)	
Exhaust manifold material & mass kg. (lbs.)**	Cast Iron, 4.0 (8.8)	
Knock sensor (number & location)	Yes	
Fuel required unleaded, diesel, etc.	Unleaded	
Fuel antiknock index (R + M) + 2	87	
Engine Mounts	Quantity	4
	Material and type (elastomeric, hydroelastic, hydraulic damper, etc.)	RH: Hydroelastic Other: Elastomeric
	Added isolation (sub-frame, crossmember, etc.)	Fr: CTR Member, RR: Sub-Frame; RH: RH Side Member; LH: LH Side Member
Total dressed engine mass (wt) dry***	M/T: 124 kg (273.6 lbs)	A/T: 116 kg (255.7 lbs)

### Engine - Pistons

Material & mass, g (weight, oz.) - piston only	Aluminum Alloy, 268 (9.5)
--	---------------------------

### Engine - Camshaft

Location	Over Cylinder Head	
Material & mass kg (weight, lbs.)	Gray Cast Iron, Intake = 1.9 (.419) Exhaust = 2.1 (.462)	
Drive type	Chain / belt	Belt
	Width / pitch	8.0 / 21.1 mm (.31 / .831 in.)

- \* Rear of engine - drive takeoff. View from drive takeoff end to determine left & right side of engine.
- \*\* Finished state.
- \*\*\* Dressed engine mass (weight) includes the following: All those items necessary to make the engine a complete ready-to-run unit.



# MVMA Specifications

Vehicle Line Geo PRIZM  
 Model Year 1995 Issued 9/94 Revised (•) \_\_\_\_\_

## METRIC (U.S. Customary)

Engine Description  
 Engine Code

1.6 LITER L4 (97 CID) MULTI-PORT FUEL INJECTION RPO LO1

### Engine - Valve System

Hydraulic lifters (std., opt., n.a.)	Not Applicable	
Valves	Number intake / exhaust	8/8
	Head O.D. intake / exhaust	31/24.5 mm (1.2/.964 in.)

### Engine - Connecting Rods

Material & mass kg., (weight, lbs.)*	Forged Steel, 0.44 (0.97)
Length (axes C/L to C/L)	122 mm (4.8 in.)

### Engine - Crankshaft

Material & mass kg., (weight, lbs.)*	Forged Steel, 12.2 (26.9)	
End thrust taken by bearing (no.)	# 3	
Length & number of main bearings	489 mm (19.3 in.), 5	
Seal (material, one, two piece design, etc.)	Front	Synthetic Rubber, One Piece
	Rear	Synthetic Rubber, One Piece

### Engine - Lubrication System

Normal oil pressure kPa (psi) at engine rpm	294 (42.6) / 6000
Type oil intake (floating, stationary)	Stationary
Oil filter system (full flow, part, other)	Full Flow
Capacity of c/case, less filter-refill-L (qt.)	3.1 (3.3)

### Engine - Diesel Information

Not Applicable

Diesel engine manufacturer		
Glow plug, current drain at 0°F.		
Injector nozzle	Type	
	Opening pressure kPa (psi)	
Pre-chamber design		
Fuel injection pump	Manufacturer	
	Type	
Fuel injection pump drive (belt, chain, gear)		
Supplementary vacuum source (type)		
Fuel heater (yes/no)		
Water separator, description (std., opt.)		
Turbo manufacturer		
Oil cooler-type (oil to engine coolant; oil to ambient air)		
Oil filter		

### Engine - Intake System

Not Applicable

Turbo charger - manufacturer	
Super charger - manufacturer	
Intercooler	

\* Finished State



# MVMA Specifications

Vehicle Line Geo PRIZM  
 Model Year 1995 Issued 9/94 Revised (\*) \_\_\_\_\_

## METRIC (U.S. Customary)

Engine Description  
 Engine Code

1.8 LITER L4 (108 CID) MULTI-PORT FUEL INJECTION RPO LV6

### Engine - Valve System

Hydraulic lifters (std., opt., n.a.)		Not Applicable
Valves	Number intake / exhaust	8/8
	Head O.D. intake / exhaust	31/24.5 mm (1.2/964 in.)

### Engine - Connecting Rods

Material & mass kg., (weight, lbs.)*	Forged Steel, 0.44 (0.97)
Length (axes C/L to C/L)	132.5 MM (5.2 in.)

### Engine - Crankshaft

Material & mass kg., (weight, lbs.)*	Forged Steel, 14.3 (31.5)	
End thrust taken by bearing (no.)	# 3	
Length & number of main bearings	489 mm (19.3 in.), 5	
Seal (material, one, two piece design, etc.)	Front	Synthetic Rubber, One Piece
	Rear	Synthetic Rubber, One Piece

### Engine - Lubrication System

Normal oil pressure kPa (psi) at engine rpm	294 (42.6) / 6000
Type oil intake (floating, stationary)	Stationary
Oil filter system (full flow, part, other)	Full Flow
Capacity of c/case, less filter-refill-L (qt.)	3.5 (3.7)

### Engine - Diesel Information

Not Applicable

Diesel engine manufacturer		
Glow plug, current drain at 0°F.		
Injector nozzle	Type	
	Opening pressure kPa (psi)	
Pre-chamber design		
Fuel injection pump	Manufacturer	
	Type	
Fuel injection pump drive (belt, chain, gear)		
Supplementary vacuum source (type)		
Fuel heater (yes/no)		
Water separator, description (std., opt.)		
Turbo manufacturer		
Oil cooler-type (oil to engine coolant; oil to ambient air)		
Oil filter		

### Engine - Intake System

Not Applicable

Turbo charger - manufacturer	
Super charger - manufacturer	
Intercooler	

\* Finished State





# MVMA Specifications

Vehicle Line Geo PRIZM  
 Model Year 1995 Issued 8/94 Revised (\*) \_\_\_\_\_

## METRIC (U.S. Customary)

Engine Description  
 Engine Code

1.6 LITER L4 (97 CID) MULTI-PORT FUEL INJECTION RPO L01

### Engine - Cooling System

Coolant recovery system (std., opt., n.a.)		Standard
Coolant fill location (rad., bottle)		Radiator
Radiator cap relief valve pressure kPa (psi)		90 (13.1)
Circulation thermostat	Type (choke, bypass)	Bypass
	Starts to open at °C (°F)	82 (179.6)
Water pump	Type (centrifugal, other)	Centrifugal
	GMP 1000 pump rpm	16 L/min.
	Number of pumps	1
	Drive (V-belt, other)	V-Belt
	Bearing type	Sealed
	Impeller material	Stainless Steel
	Housing material	Aluminum Alloy
By-pass recirculation type (inter., ext.)		External
Cooling System capacity	With heater - L (qt.)	6.0 (6.3) MT; 5.9 (6.2), A/T
	With air conditioner - L (qt.)	6.0 (6.3) MT; 5.9 (6.2), A/T
	Opt. equipment specify - L (qt.)	Not Applicable
Water jackets full length of cyl. (yes, no)		Yes
Water all around cylinder (yes, no)		No
Water jackets open at head face (yes, no)		No
Radiator core	Std., A/C, HD	Standard
	Type (cross-flow, etc.)	Vertical Flow
	Construction (fin & tube mechanical, brazo, etc.)	Corrugated Fin
	Material, mass kg (wgt., lbs.)	Aluminum or Copper-Brass, 3.4 (7.5), M/T; 3.1 (6.8) or 5.3 (11.7), A/T
	Width	701 mm (27.6 in.) or 699 mm (27.5 in.)
	Height	348 mm (13.7 in.) or 350 mm (13.8 in.)
	Thickness	27 mm (1.1 in.)
Fins per inch		Pitch = 3.0 mm
Radiator end tank material		Plastics
Fan	Std., elec., opt.	Electric
	Number of blades & type (flex, solid, material)	5, Plastics
	Number & location (front, rear of radiator)	1, Rear of Radiator
	Diameter & projected width	300/100 mm (11.8/3.9 in.)
	Ratio (fan to crankshaft rev.)	Not Available
	Fan cutout type	Temperature Controlled
	Drive type (direct, remote)	Electric Motor
	RPM at idle (elec.)	2180
	Motor rating (wattage/elec.)	80
	Motor switch (type & location/elec.)	Thermo Switch Thermoster at Water Inlet
	Switch point (temp./pressure/elec.)	90 Degree C
Fan shroud (material)		Plastics

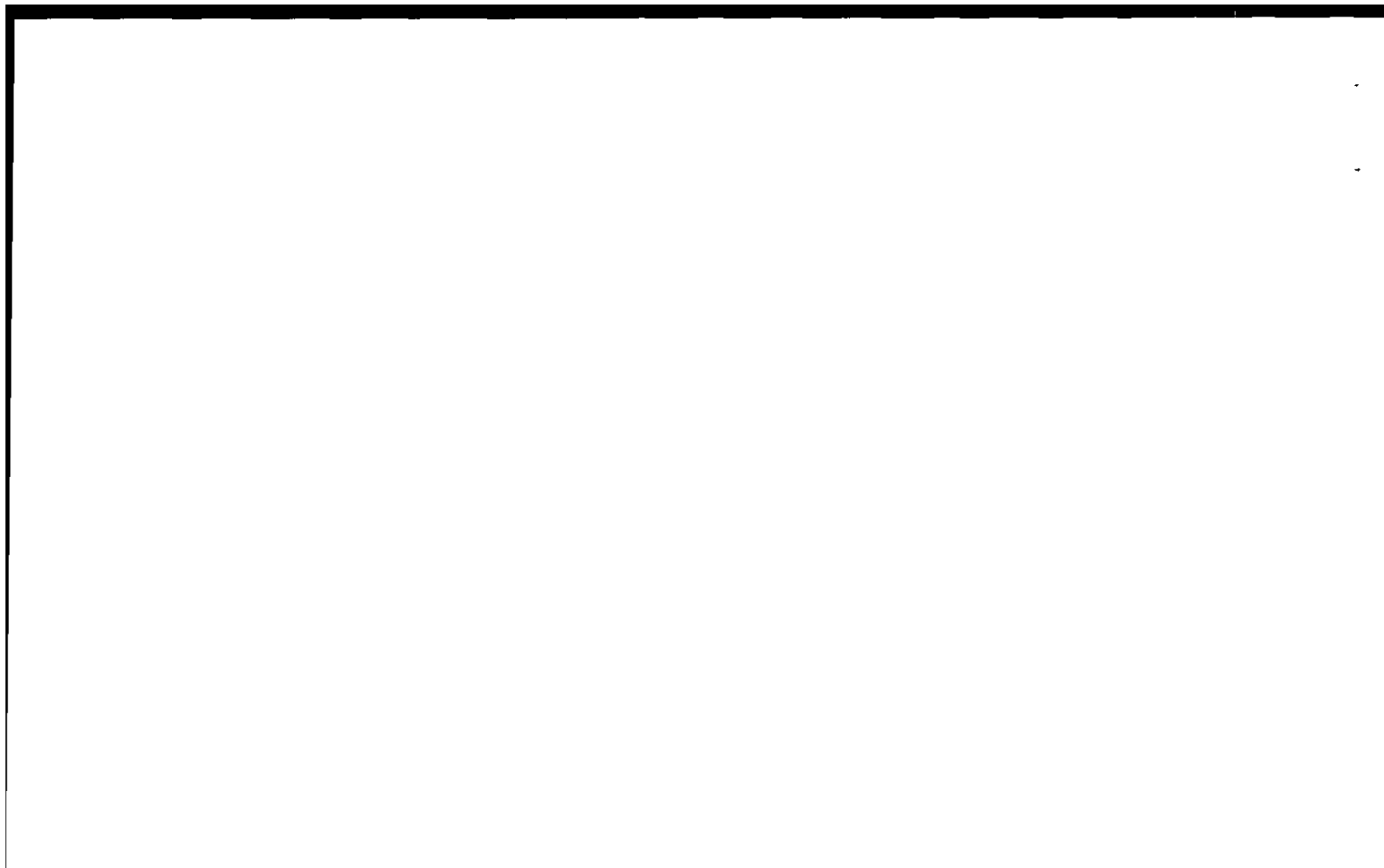

# MVMA Specifications

Vehicle Line Geo PRIZM  
 Model Year 1995 Issued 9/94 Revised (\*) \_\_\_\_\_

## METRIC (U.S. Customary)

Engine Description  
 Engine Code

1.8 LITER I4 (108 CID) MULTI-PORT FUEL INJECTION RPO LV6

### Engine - Cooling System

Coolant recovery system (std., opt., n.a.)		Standard
Coolant fill location (rad., bottle)		Radiator
Radiator cap relief valve pressure kPa (psi)		90 (13.1)
Circulation thermostat	Type (choke, bypass)	Bypass
	Starts to open at °C (°F)	82 (179.6)
Water pump	Type (centrifugal, other)	Centrifugal
	GMP 1000 pump rpm	16 L/min.
	Number of pumps	1
	Drive (V-belt, other)	V-Belt
	Bearing type	Sealed
	Impeller material	Stainless Steel
	Housing material	Aluminum Alloy
By-pass recirculation type (inter., ext.)		External
Cooling System capacity	With heater - L (qt.)	6.2 (6.6) MT; 6.1 (6.4) OR 6.2 (6.6), A/T
	With air conditioner - L (qt.)	6.2 (6.6) MT; 6.1 (6.4) OR 6.2 (6.6), A/T
	Opt. equipment specify - L (qt.)	Not Applicable
Water jackets full length of cyl. (yes, no)		Yes
Water all around cylinder (yes, no)		No
Water jackets open at head face (yes, no)		No
Radiator core	Std., A/C, HD	Standard
	Type (cross-flow, etc.)	Vertical Flow
	Construction (fin & tube mechanical, braze, etc.)	Corrugated Fin
	Material, mass kg (wgt., lbs.)	Aluminum or Copper-Brass, 3.4 (7.5), M/T; 3.1 (6.8) or 5.3 (11.7), A/T
	Width	701 mm (27.6 in.) or 699 mm (27.5 in.)
	Height	348 mm (13.7 in.) or 350 mm (13.8 in.)
	Thickness	27 mm (1.1 in.)
Fins per inch		Pitch = 3.0 mm
Radiator end tank material		Plastics
Fan	Std., elec., opt.	Electric
	Number of blades & type (flex, solid, material)	5, Plastics
	Number & location (front, rear of radiator)	1, Rear of Radiator
	Diameter & projected width	300/100 mm (11.8/3.9 in.)
	Ratio (fan to crankshaft rev.)	Not Available
	Fan cutout type	Temperature Controlled
	Drive type (direct, remote)	Electric Motor
	RPM at idle (elec.)	2180
	Motor rating (wattage/elec.)	80
	Motor switch (type & location/elec.)	Thermo Switch Thermoster at Water Inlet
	Switch point (temp./pressure/elec.)	90 Degree C
Fan shroud (material)		Plastics

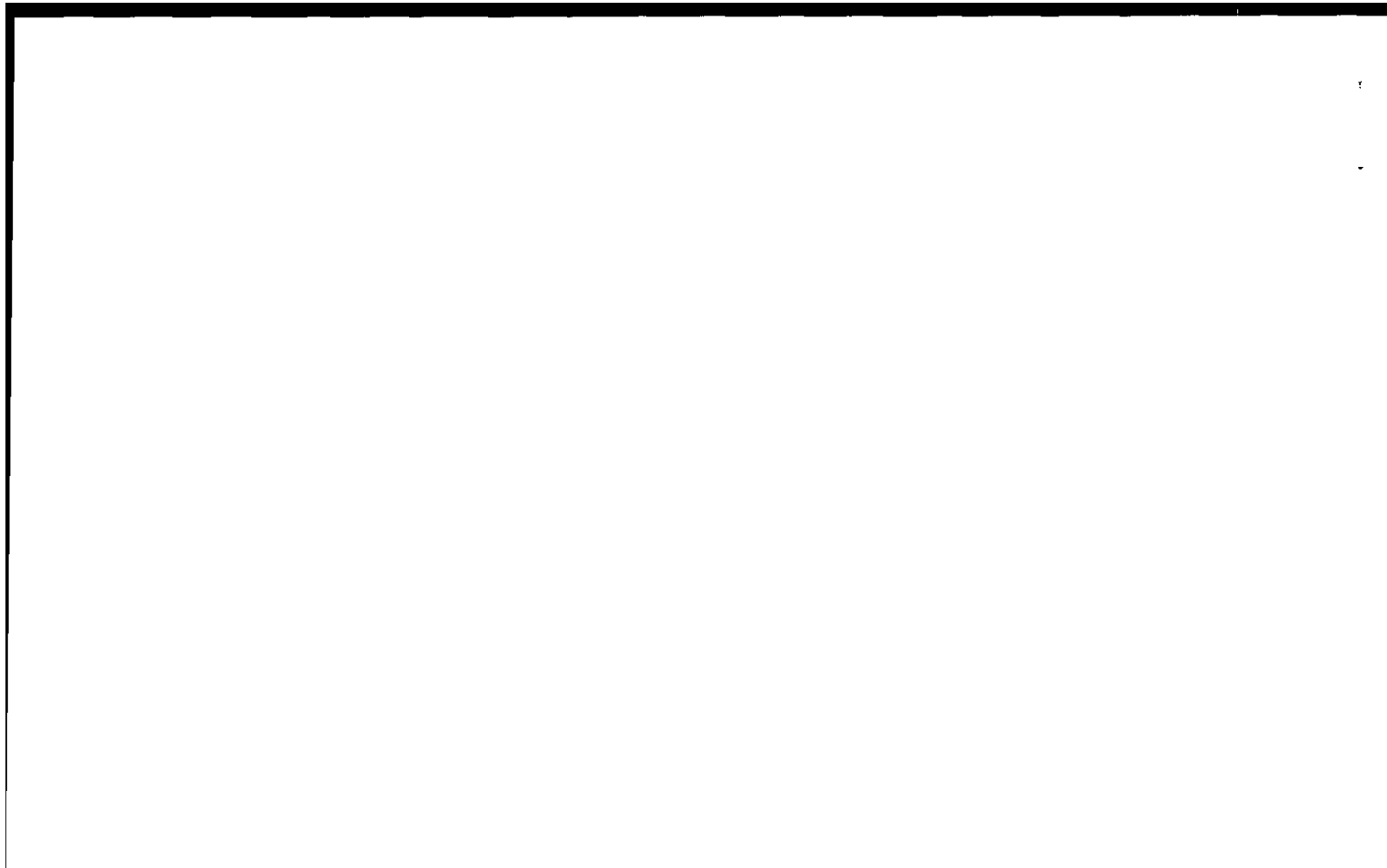

# MVMA Specifications

Vehicle Line Geo PRIZM  
 Model Year 1995 Issued 9/94 Revised (●) \_\_\_\_\_

## METRIC (U.S. Customary)

Engine Description  
 Engine Code

1.6 LITER L4 (97 CID) MULTI-PORT FUEL INJECTION RPO L01

### Engine - Fuel System (See Supplemental page for details of Fuel Injection, Supercharger, Turbocharger, etc. if used.)

Induction type: carburetor, fuel injection system, etc.		Fuel Injection
Manufacturer		Nippondenso
Carburetor no. of barrels		-
Idle A/F mix.		Not Adjustable
Fuel injection	Point of injection (no.)	4
	Constant, pulse, flow	Pulse, Flow
	Control (electronic, mech.)	Electronic
	System pressure kPa (psi)	284 (41.2)
Idle speed-rpm (spec. neutral or drive and propane if used)	Manual	700
	Automatic	700
Intake manifold heat control (exhaust or water thermostatic or fixed)		-
Air cleaner type		Oiled Paper Type, 1 Element
Fuel filter (type/location)		Paper Element 1 Piece Type at Left Side of Engine Compartment
Fuel pump	Type (elec. or mech.)	Electric
	Location (eng., tank)	In Fuel Tank
	Pressure range kPa (psi)	284 (41.2)
	Flow rate at regulated pressure L (gal)/hr @ kPa (psi)	Min. 80 (21) / hr @ 284 (41.2)

### Fuel Tank

Capacity refill L (gallons)		50 (13.2)
Location (describe)		Underside of Rear Seat Floor
Attachment		Banded & Bolts
Material & Mass kg. (weight lbs.)		Steel
Filler pipe	Location & material	Left Quarter Panel Steel
	Connection to tank	Rubber Hose
Fuel line (material)		Steel
Fuel hose (material)		Rubber
Return line (material)		Steel
Vapor line (material)		Steel
Extended range tank	Opt., n.s.	Not Applicable
	Capacity L (gallons)	"
	Location & material	"
	Attachment	"
Auxiliary tank	Opt., n.s.	Not Applicable
	Capacity L (gallons)	"
	Location & material	"
	Attachment	"
	Selector switch or valve	"
Separate fill		"



2

3

4

# MVMA Specifications

Vehicle Line Geo PRIZM  
 Model Year 1995 Issued 9/94 Revised (\*) \_\_\_\_\_

## METRIC (U.S. Customary)

Engine Description  
 Engine Code

1.8 LITER L4 (108 CID) MULTI-PORT FUEL INJECTION RPO LV6

### Engine - Fuel System (See Supplemental page for details of Fuel Injection, Supercharger, Turbocharger, etc. if used.)

Induction type: carburetor, fuel injection system, etc.		Fuel Injection
Manufacturer		Nippondenso
Carburetor no. of barrels		--
Idle A/F mix.		Not Adjustable
Fuel Injection	Point of injection (no.)	4
	Constant, pulse, flow	Pulse, Flow
	Control (electronic, mech.)	Electronic
	System pressure kPa (psi)	284 (41.2)
Idle speed-rpm (spec. neutral or drive and propane if used)	Manual	700
	Automatic	700
Intake manifold heat control (exhaust or water thermostatic or fixed)		--
Air cleaner type		Oiled Paper Type, 1 Element
Fuel filter (type/location)		Paper Element 1 Piece Type at Left Side of Engine Compartment
Fuel pump	Type (elec. or mech.)	Electric
	Location (eng., tank)	In Fuel Tank
	Pressure range kPa (psi)	284 (41.2)
	Flow rate at regulated pressure L (gal)/hr @ kPa (psi)	Min. 80 (21) / hr @ 284 (41.2)

### Fuel Tank

Capacity refill L (gallons)		50 (13.2)
Location (describe)		Underside of Rear Seat Floor
Attachment		Banded & Bolts
Material & Mass kg. (weight lbs.)		Steel
Filler pipe	Location & material	Left Quarter Panel Steel
	Connection to tank	Rubber Hose
Fuel line (material)		Steel
Fuel hose (material)		Rubber
Return line (material)		Steel
Vapor line (material)		Steel
Extended range tank	Opt., n.a.	Not Applicable
	Capacity L (gallons)	"
	Location & material	"
	Attachment	"
Auxiliary tank	Opt., n.a.	Not Applicable
	Capacity L (gallons)	"
	Location & material	"
	Attachment	"
	Selector switch or valve	"
	Separate fill	"





1

2

3



# MVMA Specifications

Vehicle Line Geo PRIZM  
 Model Year 1995 Issued 9/94 Revised (●) \_\_\_\_\_

## METRIC (U.S. Customary)

Engine Description  
 Engine Code

1.6 LITER L4 (97 CID) MULTI-PORT FUEL INJECTION RPO L01

### Vehicle Emission Control

Type (air injection, engine modifications, other)		EFI + Oxygen Sensor + TWC, Fed; EFI + Oxygen Sensor + TWC + EGR, Calif.		
Exhaust Emission Control	Air Injection	Pump or pulse	Not Applicable	
		Driven by	-	
		Air distribution (head, manifold, etc.)	-	
		Point of entry	-	
	Exhaust Gas Recirculation	Type (controlled flow, open orifice, other)	Controlled Flow, Calif.	
		Exhaust source	Cylinder Head Port, Calif.	
		Point of exhaust injection (spacer, carburetor, manifold, other)	Intake Manifold, Calif.	
	Catalytic Converter	Type	TWC	
		Number of	1, Fed.; 1+1, Calif.	
		Location(s)	Forward Under Floor Area, Fed & Calif.; Exhaust Manifold, Calif.	
Volume L (in <sup>3</sup> )		1.3 (79.6), Fed.; 1.5 (91.8), Calif.-Exhaust Manifold + 0.500 (Under Floor)		
Substrate type		Monolith, Fed.; Metal Foil + Monolith, Calif.		
Noble metal type		Platinum (Pt), Rhodium (Rh)		
Noble metal concentration (g/cm <sup>2</sup> )	Pt = 1.96, Rh = 0.39, Fed. Pt = 1.58 or 0.40, Rh = 0.42 or 0.07, Calif.			
Crankcase Emission Control	Type (ventilates to atmosphere, induction system, other)		Induction System, Closed Type	
	Energy source (manifold vacuum, carburetor, other)		Manifold Vacuum	
	Discharges to (intake manifold, other)		Intake Manifold	
	Air inlet (breather cap, other)		Throttle Body	
Evaporative Emission Control	Vapor vented to (crankcase, canister, other)	Fuel Tank	Canister	
		Carburetor	-	
	Vapor storage provision		Charcoal Coal	
Electronic system	Closed loop (yes/no)		Yes	
	Open loop (yes/no)		No	

### Engine - Exhaust System

Type (single, single with cross-over, dual, other)		Single
⊘ Muffler no. & type (reverse flow, straight thru, separate resonator), Muffler volume (liters), Material & Mass kg. (weight lbs.)	1, Straight Thru; 2, Reverse Flow - Stainless Steel 2.0 (4.4), 5.0 (11.0)	
⊘ Resonator no., type, & volume (liters)	-	
Exhaust pipe	Branch o.d., wall thickness	-
	Main o.d., wall thickness	48.6/2.0 mm (1.9/.079 in.), 48.6/1.5 mm (1.9/.059 in.), Fed 48.6/1.5 mm (1.9/.059 in.), Calif.
	Material & Mass kg. (weight lbs.)	Stainless Steel, 3.5 (7.7), Fed; 3.3 (7.3) Calif.
Intermediate pipe	o.d. & wall thickness	48.6/1.2 mm (1.9/.047 in.); 42.7/1.2 mm (1.7/.047 in.)
	Material & Mass kg. (weight lbs.)	Stainless Steel, 4.9 (10.8)
Tail pipe	o.d. & wall thickness	42.7 / 1.2 mm (1.7/.047 in.), 48.6/1.0 mm (1.9/.039 in.)
	Material & Mass kg. (weight lbs.)	Stainless Steel, 6.5 (14.3)



.

.



# MVMA Specifications

Vehicle Line Geo PRIZM  
 Model Year 1995 Issued 9/94 Revised (●) \_\_\_\_\_

## METRIC (U.S. Customary)

Engine Description  
 Engine Code

1.8 LITER L4 (108 CID) MULTI-PORT FUEL INJECTION RPO LV6

### Vehicle Emission Control

Type (air injection, engine modifications, other)		EFI + Oxygen Sensor + TWC, Fed; EFI + Oxygen Sensor + TWC + EGR, Calif.		
Exhaust Emission Control	Air Injection	Pump or pulse	Not Applicable	
		Driven by	-	
		Air distribution (head, manifold, etc.)	-	
		Point of entry	-	
	Exhaust Gas	Type (controlled flow, open orifice, other)	Controlled Flow, Calif.	
		Exhaust source	Cylinder Head Port, Calif.	
	Recirculation	Point of exhaust injection (spacer, carburetor, manifold, other)	Intake Manifold, Calif.	
		Type	TWC	
	Catalytic Converter	Number of	1, Fed.; 1+1, Calif.	
		Location(s)	Forward Under Floor Area, Fed & Calif.; Exhaust Manifold, Calif.	
Volume L (in <sup>3</sup> )		1.3 (79.6), Fed.; 1.5 (91.8), Calif.-Exhaust Manifold + 0.500 (Under Floor)		
Substrate type		Monolith, Fed.; Metal Foil + Monolith, Calif.		
Noble metal type		Platinum (Pt), Rhodium (Rh)		
Noble metal concentration (g/cm <sup>2</sup> )		Pt = 1.96, Rh = 0.39, Fed. Pt = 1.58 or 0.40, Rh = 0.42 or 0.07, Calif.		
Crankcase Emission Control	Type (ventilates to atmosphere, induction system, other)		Induction System, Closed Type	
	Energy source (manifold vacuum, carburetor, other)		Manifold Vacuum	
	Discharges to (intake manifold, other)		Intake Manifold	
	Air inlet (breather cap, other)		Throttle Body	
Evaporative Emission Control	Vapor vented to (crankcase, canister, other)	Fuel Tank	Canister	
		Carburetor	-	
	Vapor storage provision		Charcoal Coal	
Electronic system	Closed loop (yes/no)		Yes	
	Open loop (yes/no)		No	

### Engine - Exhaust System

Type (single, single with cross-over, dual, other)		Single
⊗	Muffler no. & type (reverse flow, straight thru, separate resonator), Muffler volume (liters), Material & Mass kg. (weight lbs.)	1, Straight Thru; 2, Reverse Flow - Stainless Steel 2.0 (4.4), 5.0 (11.0)
⊗	Resonator no., type, & volume (liters)	-
Exhaust pipe	Branch o.d., wall thickness	-
	Main o.d., wall thickness	48.6/2.0 mm (1.9/.079 in.), 48.6/1.5 mm (1.9/.059 in.), Fed 48.6/1.5 mm (1.9/.059 in.), Calif.
	Material & Mass kg. (weight lbs.)	Stainless Steel, 3.5 (7.7), Fed; 3.3 (7.3) Calif.
Intermediate pipe	o.d. & wall thickness	48.6/1.2 mm (1.9/.047 in.); 42.7/1.2 mm (1.7/.047 in.)
	Material & Mass kg. (weight lbs.)	Stainless Steel, 4.9 (10.8)
Tail pipe	o.d. & wall thickness	42.7 / 1.2 mm (1.7/.047 in.), 48.6/1.0 mm (1.9/.039 in.)
	Material & Mass kg. (weight lbs.)	Stainless Steel, 6.5 (14.3)



.

.

|

# MVMA Specifications

Vehicle Line Geo PRIZM  
 Model Year 1995 Issued 9/94 Revised (\*) \_\_\_\_\_

## METRIC (U.S. Customary)

Engine Description  
 Engine Code

1.6 LITER L4 (97 CID) MULTI-PORT FUEL INJECTION RPO L01

### Transmissions/Transaxle (Std., Opt., N.A.)

Manual 4-speed (manufacturer/country)	Not Available
Manual 5-speed (manufacturer/country)	Standard, TMC/Japan
Manual 6-speed (manufacturer/country)	Not Available
Automatic (manufacturer/country)	Standard, TMC/ Japan
Automatic overdrive (manufacturer/country)	Not Applicable

### Manual Transmission/Transaxle

Number of forward speeds		5
Gear ratios	1st	3.545
	2nd	1.904
	3rd	1.310
	4th	0.969
	5th	0.815
	6th	-
	Reverse	3.250
Synchronous meshing (specify gears)		All Forward Speeds
Shift lever location		Floor
Trans. case material & mass kg. (lbs.)*		Aluminum Die Cast, 37.5 (82.7) - Wet
Lubricant	Capacity L (pt.)	2.6 (5.5)
	Type recommended	APT GL-3, GL-4, GL-5

### Clutch (Manual Transmission)

Clutch manufacturer		AISIN	
Clutch type (dry, wet; single, multiple disc)		Dry, Single, Diaphragm	
Linkage (hydraulic, cable, rod, lever, other)		Hydraulic	
Max. pedal effort (nom. spring load) N (lbs.)	Depressed	110 (24.7)	
	Released	110 (24.7)	
Assist (spring, power/percent, nominal)		0	
Type pressure plate springs		Diaphragm Spring	
Total spring load (nominal) N (lbs.)		4200 (944.2)	
Clutch facing	Facing mfr. & material coding	AKEBONO BRAKE	
	Facing material & construction	Semi-Mold	
	Rivets per facing	16	
	Outside x inside dia. (nominal)	212 x 140 mm (8.3 x 5.51 in.)	
	Total eff. area cm <sup>2</sup> (in. <sup>2</sup> )	199 (30.8)	
	Thickness (pressure plate side/fly wheel side)	3.5 mm (.138 in.)	
	Rivet depth (pressure plate side/fly wheel side)	1.6 / 1.6 mm (.063 / .063 in.)	
Engagement cushion method		Wave Spring Segments	
Release bearing type & method lub.		Self-Centering Ball Bearing with Permanent Lubrication	
Torsional damping method, springs, hysteresis		Single-Stage Torsional Rubber with Friction Washer	

\* Includes shift linkage, lubricant, and clutch housing. If other specify.



2

3



# MVMA Specifications

Vehicle Line Geo PRIZM  
 Model Year 1995 Issued 9/94 Revised (\*) \_\_\_\_\_

## METRIC (U.S. Customary)

Engine Description  
 Engine Code

1.8 LITER L4 (108 CID) MULTI-PORT FUEL INJECTION RPO LV6

### Transmissions/Transaxle (Std., Opt., N.A.)

Manual 4-speed (manufacturer/country)	Not Available
Manual 5-speed (manufacturer/country)	Standard, TMC/Japan
Manual 6-speed (manufacturer/country)	Not Available
Automatic (manufacturer/country)	Standard, AISIN AW/ Japan
Automatic overdrive (manufacturer/country)	Not Applicable

### Manual Transmission/Transaxle

Number of forward speeds		5
Gear ratios	1st	3.166
	2nd	1.904
	3rd	1.310
	4th	0.969
	5th	0.815
	6th	-
	Reverse	3.250
Synchronous meshing (specify gears)		All Forward Speeds
Shift lever location		Floor
Trans. case material & mass kg. (lbs.)*		Aluminum Die Cast, 37.5 (82.7) - Wet
Lubricant	Capacity L. (pt.)	2.6 (5.5)
	Type recommended	APT GL-3, GL-4, GL-5

### Clutch (Manual Transmission)

Clutch manufacturer		AISIN
Clutch type (dry, wet; single, multiple disc)		Dry, Single, Diaphragm
Linkage (hydraulic, cable, rod, lever, other)		Hydraulic
Max. pedal effort (nom. spring load) N (lbs.)	Depressed	120 (27.0)
	Released	120 (27.0)
Assist (spring, power/percent, nominal)		0 w/ABS, 30 w/o ABS
Type pressure plate springs		Diaphragm Spring
Total spring load (nominal) N (lbs.)		4400 (989.2)
Clutch facing	Facing mfg. & material coding	AKEBONO BRAKE
	Facing material & construction	Semi-Mold
	Rivets per facing	16
	Outside x inside dia. (nominal)	212 x 140 mm (8.3 x 5.51 in.)
	Total eff. area cm <sup>2</sup> (in. <sup>2</sup> )	199 (30.8)
	Thickness (pressure plate side/fly wheel side)	3.5 mm (.138 in.)
	Rivet depth (pressure plate side/fly wheel side)	1.6 / 1.6 mm (.063 / .063 in.)
Engagement cushion method		Wave Spring Segments
Release bearing type & method lub.		Self-Centering Ball Bearing with Permanent Lubrication
Torsional damping method, springs, hysteresis		Single-Stage Torsional Rubber with Friction Washer

\* Includes shift linkage, lubricant, and clutch housing. If other specify.





•

•



# MVMA Specifications

Vehicle Line Geo PRIZM  
 Model Year 1995 Issued 9/94 Revised (e) \_\_\_\_\_

METRIC (U.S. Customary)

Engine Description  
 Engine Code

1.6 LITER L4 (97CID) MULTI-PORT FUEL INJECTION RPO L01

## Automatic Transmission/Transaxle

Trade Name		A131L
Type and special features (describe)		2-Mode, 3-Speed Hydraulically Controlled Planetary Gear Train with Lock-Up Clutch
Shift mechanics		
Gear selector	Location (column, floor, other)	Floor
	Ltr./No. designation (e.g. PRND21)	P-R-N-D-2-L
	Shift interlock (yes, no, describe)	Yes
Gear ratios	1st	2.810
	2nd	1.549
	3rd	1.000
	4th	Not Applicable
	5th	"
	6th	"
	Reverse	2.296
Final drive ratio		
Max. upshift vehicle speed - drive range km/h (mph)		113 (70.2)
Max. upshift engine speed RPM		
Max. lockdown speed - drive range km/h (mph)		108 (67.1)
Min. overdrive speed km/h (mph)		-
Torque converter	Type	
	Torus design	
	Number of elements	3 Elements - 1st Stage, 2-Phases
	Max. ratio at stall	2.3
	Type of cooling (air, liquid)	Liquid
	Nominal diameter	230 mm (9.05 in.)
Capacity factor "K"		-
Pump type		
Lubricant	Capacity refill L (pt.)	2.5 (5.3); Dryfill, 5.5 (11.6)
	Type recommended	ATF Dexron II
Oil cooler (std., opt., N.A., internal, external, air, liquid)		In Radiator, Liquid
Transmission mass kg (lbs.) & case material**		59.2 (130.5), Aluminum Die Cast

## All Wheel / 4 Wheel Drive

Not Applicable

Description & type (part-time, full-time, 2/4 shift while moving, mechanical, elect., chain/gear, etc.)		
Transfer case	Manufacturer and model	
	Type and location	
Low-range gear ratio		
System disconnect (describe)		
Center differential	Type (bevel, planetary, w or w/o viscous bias, torsen, etc.)	
	Torque split (% front/rear)	

\* Input speed +  $\sqrt{\text{torque}}$

\*\* Dry weight including torque converter. If other, specify.



4

4



# MVMA Specifications

Vehicle Line Geo PRIZM  
 Model Year 1995 Issued 9/94 Revised (\*) \_\_\_\_\_

## METRIC (U.S. Customary)

Engine Description  
 Engine Code

1.8 LITER L4 (108 CID) MULTI-PORT FUEL INJECTION RPO LV6

### Automatic Transmission/Transaxle

Trade Name		A245e
Type and special features (describe)		2-Mode, 4-Speed electronically Controlled Planetary Gear Train with Lock-Up Clutch
Shift mechanics		
Gear selector	Location (column, floor, other)	Floor
	Ltr./No. designation (e.g. PRND21)	P-R-N-D-2-L
	Shift interlock (yes, no, describe)	Yes
Gear ratios	1st	3.643
	2nd	2.008
	3rd	1.296
	4th	0.892
	5th	Not Available
	6th	-
	Reverse	2.977
Final drive ratio		
Max. upshift vehicle speed - drive range km/h (mph)		144 (89.5)
Max. upshift engine speed RPM		
Max. lockdown speed - drive range km/h (mph)		139 (86.4)
Min. overdrive speed km/h (mph)		19 (11.8)
Torque converter	Type	
	Torus design	
	Number of elements	3 Elements - 1st Stage, 2-Phases
	Max. ratio at stall	2.3
	Type of cooling (air, liquid)	Liquid
	Nominal diameter	230 mm (9.05 in.)
Capacity factor "K"		-
Pump type		
Lubricant	Capacity refill L (pt.)	3.3 (7.0); Dryfill, 7.6 (16.1)
	Type recommended	ATF Dexron II
Oil cooler (std., opt., N.A., internal, external, air, liquid)		In Radiator, Liquid
Transmission mass kg (lbs.) & case material**		71.8 (158.3), Aluminum Die Cast

### All Wheel / 4 Wheel Drive

Not Applicable

Description & type (part-time, full-time, 2/4 shift while moving, mechanical, elect., chain/gear, etc.)		
Transfer case	Manufacturer and model	
	Type and location	
Low-range gear ratio		
System disconnect (describe)		
Center differential	Type (bevel, planetary, w or w/o viscous bias, torsen, etc.)	
	Torque split (% front/rear)	

\* Input speed  $\div \sqrt{\text{torque}}$

\*\* Dry weight including torque converter. If other, specify.

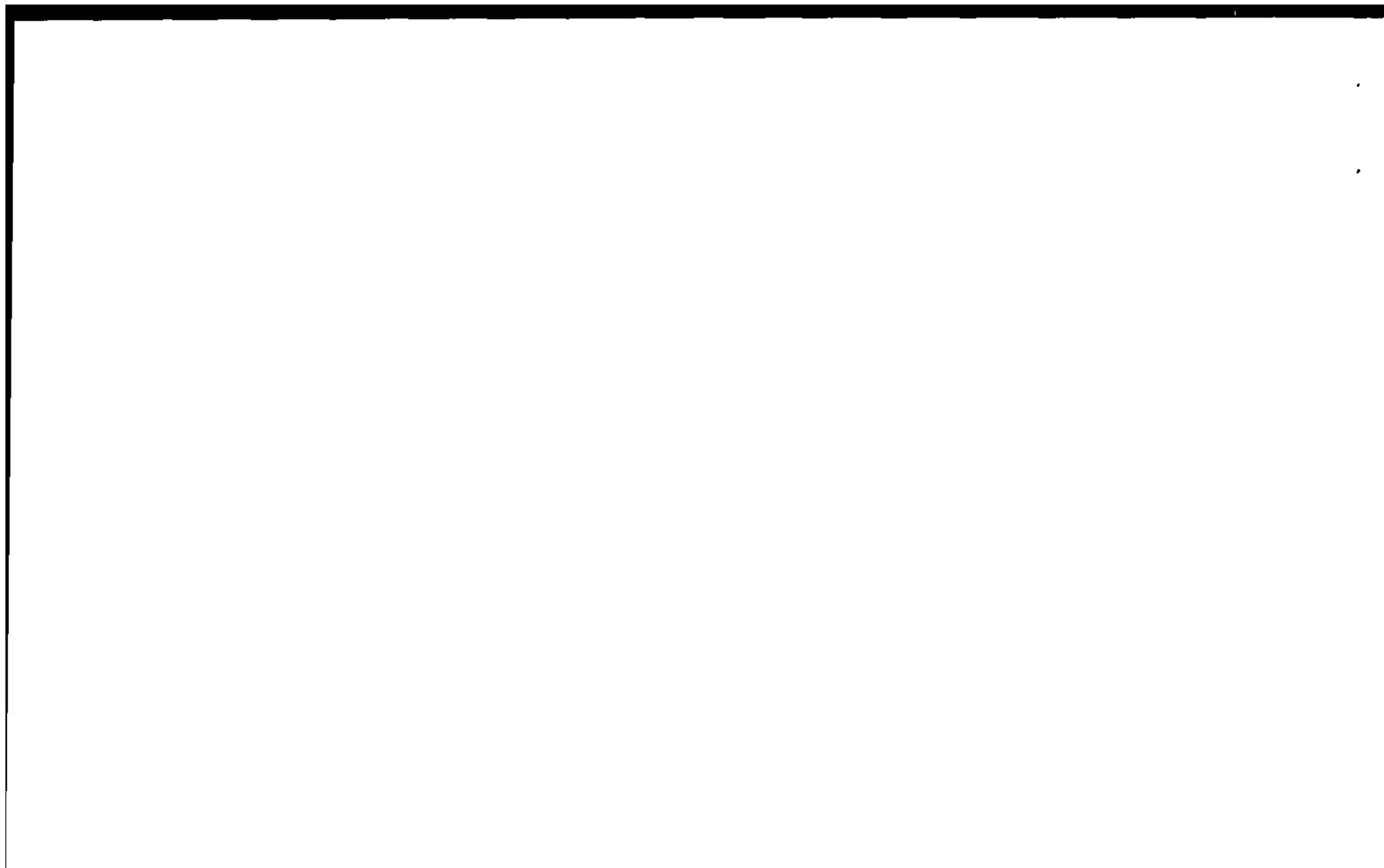

# MVMA Specifications

Vehicle Line Geo PRIZM  
 Model Year 1995 Issued 9/94 Revised (#) \_\_\_\_\_

## METRIC (U.S. Customary)

Engine Description  
 Engine Code

1.6 LITER L4 (97 CID) MULTI-PORT FUEL INJECTION RPO L01

### Axle Ratio and Tooth Combinations (See 'Power Teams' for axle ratio usage)

Effective final drive ratio (or overall top gear ratio)		A/T: 3.53
Transfer ratio and method (chain, gear, etc.)		-
Front drive unit	Ring gear o.d.	-
	No. of teeth	A/T: 19
	Pinion Ring gear	A/T: 67

### Front Drive Unit

Description (integral to trans., etc.)		Integral to Transmission
Limited slip differential (type)		-
Drive pinion	Type	Helical Gear
	Offset	-
No. of differential pinions		2
Pinion / differential	Adjustment (shim, etc.)	-
	Bearing adjustment	-
Driving wheel bearing (type)		Double Row Angular Contact Ball Bearing
Lubricant	Capacity L (pt.)	1.4 (3.0), A/T
	Type recommended	ATF Dexron II
SAE Viscosity Number		

### Axle Shafts - Front Wheel Drive

Manufacturer and number used		GM Saginaw, 2	
Type (straight, solid bar, tubular, etc.)		Left Solid Bar Right Solid Bar	
Outer diam. x length* x wall thickness	Manual Transaxle	Left 24.2 x 340.1 mm (.953 x 13.4 in.)	
		Right 24.2 x 657.3 mm (.953 x 25.9 in.)	
	Automatic transaxle	Left 24.2 x 340.1 mm (.953 x 13.4 in.)	
		Right 24.2 x 657.3 mm (.953 x 25.9 in.)	
	Optional transaxle	Left -	
		Right -	
Slip yoke	Type	-	
	Number of teeth	-	
	Spline o.d.	-	
Universal joints	Make and mfg. no.	Inner GM Saginaw, 43047-02030; TMC 43403-12040	
		Outer GM Saginaw, 43405-02040,02030; TMC 43405-12022, 12051	
	Number used		4, 2 Each Shaft
	Type, size, plunge	Inner Tripot, Plunge	
		Outer Rzeppa, Fixed	
	Attach (u-bolt, clamp, etc.)		Snap Ring
Bearing	Type (plain, anti-friction)	-	
	Lubrication (fitting, prepack)	-	
Drive taken through (torque tube, arms or springs)		MacPherson Strut	
Torque taken through (torque tube, arms or springs)		Engine Mounting System	

\* Centerline to centerline of universal joints, or to centerline of attachment.

---

.

.

---

# MVMA Specifications

Vehicle Line Geo PRIZM  
 Model Year 1995 Issued 9/94 Revised (●) \_\_\_\_\_

## METRIC (U.S. Customary)

Engine Description  
 Engine Code

1.8 LITER L4 (108 CID) MULTI-PORT FUEL INJECTION RPO LV6

### Axle Ratio and Tooth Combinations (See 'Power Teams' for axle ratio usage)

Effective final drive ratio (or overall top gear ratio)		A/T: 2.82
Transfer ratio and method (chain, gear, etc.)		-
Front drive unit	Ring gear o.d.	-
	No. of teeth	Pinion A/T: 28
	Ring gear	A/T: 79

### Front Drive Unit

Description (integral to trans., etc.)		Integral to Transmission
Limited slip differential (type)		-
Drive pinion	Type	Helical Gear
	Offset	-
No. of differential pinions		2
Pinion / differential	Adjustment (shim, etc.)	-
	Bearing adjustment	-
Driving wheel bearing (type)		Double Row Angular Contact Ball Bearing
Lubricant	Capacity L (pt.)	Included in Automatic Transmission
	Type recommended	ATF Dexron II
SAE Viscosity Number		

### Axle Shafts - Front Wheel Drive

Manufacturer and number used		TMC	
Type (straight, solid bar, tubular, etc.)	Left	Solid Bar	
	Right	Solid Bar	
Outer diam. x length* x wall thickness	Manual Transaxle	Left	22.3 x 354.1 mm (.878 x 13.9 in.)
		Right	26.0 x 668.6 mm (1.0 x 26.3 in.)
	Automatic transaxle	Left	22.3 x 354.1 mm (.878 x 13.9 in.)
		Right	26.0 x 668.6 mm (1.0 x 26.3 in.)
	Optional transaxle	Left	-
		Right	-
Slip yoke	Type	-	
	Number of teeth	-	
	Spline o.d.	-	
Universal joints	Make and mfg. no.	Inner	GM Saginaw, 43047-02030; TMC 43403-12040
		Outer	GM Saginaw, 43405-02040, 02030; TMC 43405-12022, 12051
	Number used		4, 2 Each Shaft
	Type, size, plunge	Inner	Tripot, Plunge
		Outer	Rzeppa, Fixed
	Attach (u-bolt, clamp, etc.)		Snap Ring
Bearing	Type (plain, anti-friction)	-	
	Lubrication (fitting, prepack)	-	
Drive taken through (torque tube, arms or springs)		MacPherson Strut	
Torque taken through (torque tube, arms or springs)		Engine Mounting System	

\* Centerline to centerline of universal joints, or to centerline of attachment.





.

.



# MVMA Specifications

Vehicle Line Geo PRIZM  
 Model Year 1995 Issued 9/94 Revised (●) \_\_\_\_\_

## METRIC (U.S. Customary)

Model Code/Description And/Or  
 Engine Code/Description

PRIZM

PRIZM LSi

### Suspension - General Including Electronic Controls

Car leveling	Standard/optional/not available		Not Available	
	Manual/automatic control		"	
	Type (air/hydraulic)		"	
	Primary/assist spring		"	
	Rear only/4 wheel leveling		"	
	Single/dual rate spring		"	
	Single/dual ride heights		"	
	Provision for jacking		Not Available	
Shock absorber damping controls	Standard/option/not available		"	
	Manual/automatic control		"	
	Number of damping rates		"	
	Type of actuation (manual/electric motor/air, etc.)		"	
	Sensors	Lateral acceleration		"
		Deceleration		"
		Acceleration		"
Road surface		"		
Shock absorber (front & rear)	Type		Tube Double Acting	
	Make		Delco	
	Piston diameter		32.0 mm (1.26 in.)	
	Rod diameter		20.0 mm (.79 in.)	

### Suspension - Front

Type and description		MacPherson Strut
Travel	Full jounce (define load condition)	80 mm (3.1 in.)
	Full rebound	85 mm (3.35 in.)
Spring	Type (coil, leaf, other & material)	Coil, Alloy Steel
	Insulators (type & material)	Top and Bottom Rubber
	Size (Leaf: length & width; Coil: design height & I.d.; Bar: length & diameter)	See Page 11A
	Spring rate N/mm (lb./in.)	21.6 (191.2) <span style="float: right;">22.5 (199.2)</span>
	Rate at wheel N/mm (lb./in.)	19.6 (173.5) <span style="float: right;">20.6 (182.3)</span>
Stabilizer	Type (link, linkless, frameless)	-
	Material & O.D. bar/tube, wall thickness	-

### Suspension - Rear

Type and description		MacPherson Strut	
Travel	Full jounce (define load condition)	85 mm (3.35 in.)	
	Full rebound	100 mm (3.93 in.)	
Spring	Type (coil, leaf, other & material)	Coil, Alloy Steel	
	Size (Leaf: length & width; Coil: design height & I.d.; Bar: length & diameter)	320.5 x (128.6-88.6) <span style="float: right;">325.5 x (128.5-88.5)</span>	
	Spring rate N/mm (lb./in.)	18.6 (164.6)	
	Rate at wheel N/mm (lb./in.)	17.6 (155.8)	
	Insulators (type & material)		Top & Bottom, Rubber
	If leaf	No. of leaves	-
		Shackle (comp. or tens.)	-
Stabilizer	Type (link, linkless, frameless)	Link	
	Material & O.D. bar/tube, wall thickness	Alloy Steel, 14 mm (.551 in.)	
Track bar (type)			



.

.



# MVMA Specifications

Vehicle Line Geo PRIZM  
 Model Year 1995 Issued 9/94 Revised (\*)           

## METRIC (U.S. Customary)

### SUPPLEMENTAL PAGE

1) Geo PRIZM

<i>Bodystyle</i>	<i>Transaxle</i>	RH		LH	
		<i>w/o A/C</i>	<i>w/A/C</i>	<i>w/o A/C</i>	<i>w/A/C</i>
Notchback	Manual	310.0 x 127.9	316.5 x 127.9	316.5 x 127.9	323.0 x 127.9
Notchback	Auto	316.5 x 127.9	323.0 x 127.9	323.0 x 127.9	329.5 x 127.9

2) Geo PRIZM LSi

<i>Bodystyle</i>	<i>Transaxle</i>	RH		LH	
		<i>w/o A/C</i>	<i>w/A/C</i>	<i>w/o A/C</i>	<i>w/A/C</i>
All	Manual	323.0 x 127.9	330.0 x 127.9	330.0 x 127.9	336.5 x 127.9
All	Auto	330.0 x 127.9	336.5 x 127.9	336.5 x 127.9	343.5 x 127.9



•

•



# MVMA Specifications

Vehicle Line Geo PRIZM  
 Model Year 1995 Issued 9/94 Revised (●) \_\_\_\_\_

METRIC (U.S. Customary)

Model Code/Description And/Or  
 Engine Code/Description

ALL MODELS

## Brakes - Service

Description			
Manufacturer and brake type (std., opt., n.a.)	Front (disc or drum)	AM BRAKE, Disc, Standard	
	Rear (disc or drum)	AM BRAKE, Drum, Standard	
Valving type (proportion, delay, metering, other)		P-Valve	
Power brake (std., opt., n.a.)		Standard	
Booster type (remote, integral, vac., hyd., etc.)		Integral, Vacuum	
Vacuum	Source (inline, pump, etc.)	Inline	
	Reservoir (volume in. <sup>3</sup> )	Not Available	
	Pump-type (elec., gear or belt driven)	"	
Traction assist	Operational speed range	Not Available	
	Type (engine or brake intervention)	"	
Antilock device	Front/rear (std., opt., n.a.)	Front and Rear (Optional)	
	Manufacturer	General Motors Delco Chassis Division	
	Type (electronic, mech.)	Electronic	
	Number sensors or circuits	4	
	Number antilock hydraulic circuits	4	
	Integral or add-on system	Add-On	
	Yaw control (yes, no)	Yes	
Hyd. power source (elec., vac., mtr., pwr., strg.)		Electric Motor	
Effective area cm <sup>2</sup> (in. <sup>2</sup> )*		187/230	
Gross Lining area cm <sup>2</sup> (in. <sup>2</sup> )** (F/R)		191/230	
Swept area cm <sup>2</sup> (in. <sup>2</sup> )** (F/R)		1236/377	
Rotor	Outer working diameter	F/R 255/N.A.	
	Inner working diameter	F/R 156/N.A.	
	Thickness	F/R 22/N.A.	
	Material & type (vented/solid)	F/R Cast Iron, Vented/N.A.	
Drum	Diameter & width	F/R N.A./200	
	Type and material	F/R N.A./Cast Iron	
Wheel cylinder bore		54.00/17.46	
Master cylinder	Bore/stroke	F/R 20.6/28 (Normal), 22.2/28 (ABS)	
Pedal arc ratio		3.8	
Line press. at 445 N (100 lb.) pedal load [kPa (psi)]		11954 (Normal), 12794 (ABS)	
Lining clearance		F/R Self Adjust/Self Adjust	
Brake lining	Front wheel	Bonded or riveted (rivets/seg.)	Bonded
		Rivet Size	-
		Manufacturer	NISSHINBO, AKEBONO, AISIN, SUMITOMO, BENDIX
		Lining code *****	-
		Material	Molded Resin
		**** Primary or out-board	117 x 49 x 12 mm (4.6 x 1.9 x .472 in.)
		**** Secondary or in-board	117 x 49 x 12 mm (4.6 x 1.9 x .472 in.)
	Shoe thickness (no lining)	5.5	
	Rear wheel	Bonded or riveted (rvts/seg.)	Bonded
		Manufacturer	NISSHINBO, AKEBONO
		Lining code *****	-
		Material	Molded Resin
		**** Primary or out-board	192 x 30 x 4 mm (7.56 x 1.18 x .157 in.)
		**** Secondary or in-board	192 x 30 x 4 mm (7.56 x 1.18 x .157 in.)
Shoe thickness (no lining)		1.6 mm (.063 in.)	

\* Excludes rivet holes, grooves, chamfers, etc.

\*\* Includes rivet holes, grooves, chamfers, etc.

\*\*\* Total swept area for four brakes. (Drum brake: Widest lining contact width for each brake x its contact circumference.) (Disc brake: Square of Outer Working Dia. minus Square of inner Working Dia. multiplied by Pi/2 for each brake.)

\*\*\*\* Size for drum brakes includes length x width x thickness. \*\*\*\*\*Manufacturer I.D., catalog for formulation designation and coefficient of friction classification.



2

3



# MVMA Specifications

Vehicle Line Geo PRIZM  
 Model Year 1995 Issued 9/94 Revised (\*) \_\_\_\_\_

## METRIC (U.S. Customary)

Model Code/Description And/Or  
 Engine Code/Description

PRIZM	PRIZM LSi
-------	-----------

### Tires And Wheels (Standard)

Tires	Size (service description)		P175/65R14 81S	P185/65R14 85S
	Type (bias, radial, steel, nylon, etc.)		Radial, Steel	
	Inflation pressure (cold) for recommended max. vehicle load	Front kPa (psi)	210 (30.5)	
		Rear kPa (psi)	210 (30.5)	
	Rev./mile at 70 km/h (45 mph)		911	896
Wheels	Type & material		Steel	
	Rim (size & flange type)		14 x 5 1/2J	
	Wheel offset		45.0 mm (1.77 in.)	
	Attachment	Type (bolt or stud & nut)	Stud & Nut	
		Circle diameter	T115/70D14, 14 x 4T	
Number & size		4-M12 x 1.5		
Spare	Tire and wheel		T115/70D14, 14 x 4T	T135/70D15, 15 x 4T
	Storage position & location (describe)		Flat in Trunk Room Well	

### Tires And Wheels (Optional)

Tire size (service description)		P185/65R14 85S
Type (bias, radial, steel, nylon, etc.)		Radial, Steel
Wheel (type & material)		Aluminum
Rim (size, flange type and offset)		14 x 5 1/2JJ, 45
Tire size (service description)		
Type (bias, radial, steel, nylon, etc.)		
Wheel (type & material)		
Rim (size, flange type and offset)		
Tire size (service description)		
Type (bias, radial, steel, nylon, etc.)		
Wheel (type & material)		
Rim (size, flange type and offset)		
Spare tire and wheel size		
(If configuration is different than road tire or wheel, describe optional spare tire and/or wheel location & storage position)		T135/70D15, 15 x 4T

### Brakes - Parking

Type of control		Hand Operate Type
Location of control		Center Floor
Operates on		Rear Brake
If separate from service brakes	Type (internal or external)	--
	Drum diameter	--
	Lining size (length x width x thickness)	--





# MVMA Specifications

Vehicle Line Geo PRIZM  
 Model Year 1995 Issued 9/94 Revised (●) \_\_\_\_\_

## METRIC (U.S. Customary)

Model Code/Description And/Or  
 Engine Code/Description

PRIZM	PRIZM LSi
-------	-----------

### Steering

Manual (std., opt., n.a.)		Standard	Not Applicable		
Power (std., opt., n.a.)		Optional	Standard		
Speed-sensitive (std., opt., n.a.)					
4-wheel steering (std., opt., n.a.)		Not Available			
Adjustable steering wheel/column (tilt, telescope, other)	Type	Non Adjustable	Tilt	Non Adjustable	Tilt
	Manufacturer	TOYOTA or NASTEC	NASTEC	TOYOTA or NASTEC	NASTEC
	(std., opt., n.a.)	Standard	Optional	Standard	Optional
Wheel diameter** (W9) SAE J1100	Manual	380 mm (14.96 in.)			
	Power	380 mm (14.96 in.)			
Turning diameter m (ft.)	Outside front	Wall to wall (l. & r.)	5.2 (17.1)		
		Curb to curb (l. & r.)	4.9 (16.1)		
	Inside rear	Wall to wall (l. & r.)	2.6 (8.5)		
		Curb to curb (l. & r.)	2.6 (8.5)		
Scrub Radius*		8			
Manual	Gear	Type	R & P		
		Manufacturer	KOYO		
	Ratios	Gear			
		Overall	22.7		
No. wheel turns (stop to stop)		4.09			
Power	Type (coaxial, elec. hyd., etc.)		Integral		
	Manufacturer		TKS		
	Gear	Type	R & P		
		Ratios	Gear		
	Overall		18.1		
	Pump (drive)		V-Ribbed Belt		
No. wheel turns (stop to stop)		3.27			
Linkage	Type		Ackermann		
	Location (front or rear of wheels, other)		Rear of Wheels		
	Tie rods (one or two)		2		
Steering axis	Inclination at camber (deg.)		12 deg. 40'		
	Bearings (type)	Upper	Ball Bearing		
		Lower	Ball Joint		
		Thrust	-		
Steering spindle/knuccle & joint type		MacPherson Strut and Ball Joint			

\* The horizontal distance in the front elevation between wheel centerline and kingpin (ball joint) axis at ground.

\*\* See Page 23.

---

---

---

# MVMA Specifications

Vehicle Line Geo PRIZM  
 Model Year 1995 Issued 9/94 Revised (●) \_\_\_\_\_

## METRIC (U.S. Customary)

Model Code/Description And/Or  
 Engine Code/Description

ALL MODELS

### Wheel Alignment

Front wheel at curb mass (wt.)	Service checking	Caster (deg.)	1 deg. 20' ± 45'
		Camber (deg.)	-10' ± 45'
		Toe-in outside track mm (in.)	1 ± 2
	Service reset*	Caster (deg.)	1 deg. 20' ± 30'
		Camber (deg.)	-10' ± 30'
		Toe-in mm (in.)	1 ± 1
	Periodic M.V. inspection	Caster (deg.)	Not Available
		Camber (deg.)	"
		Toe-in mm (in.)	"
Rear wheel at curb mass (wt.)	Service checking	Camber (deg.)	-55' ± 45'
		Toe-in outside track mm (in.)	3 ± 2
	Service reset*	Camber (deg.)	-55' ± 30'
		Toe-in mm (in.)	3 ± 1
	Periodic M.V. insp.	Camber (deg.)	Not Available
		Toe-in mm (in.)	"

\* Indicates pre-set, adjustable, trend set or other.

### Electrical - Instruments and Equipment

Speedometer	Type (analog, digital, std., opt.)	Analog	
	Trip odometer (std., opt., n.a.)	Standard	
Head-up display	Standard, optional, not available		Not Available
	Type	Secondary, opto-electronic	"
	Speedometer	Digital	"
	Status/warning indicators	Turn signals, high beam, low fuel, check gauges	"
	Brightness control	Day / night mode, adjustable	"
EGR maintenance indicator		"	
Charge indicator	Type	Telltale Lamp	
	Warning device (light, audible)	Light	
Temperature Indicator	Type	Electric Gauge	
	Warning device (light, audible)	Not Available	
Oil pressure indicator	Type	Telltale Lamp	
	Warning device (light, audible)	Light	
Fuel indicator	Type	Electric Gauge	
	Warning device (light, audible)	Light	
Windshield wiper	Type (standard)	Electric 2-Speed and Mist	
	Type (optional)	Electric 2-Speed with Adjustable Intermittent	
	Blade length	LH = 500 mm; RH = 450 mm	
Windshield washer	Swept area cm <sup>2</sup> (in. <sup>2</sup> )	6390	
	Type (standard)	Standard Electric Motor	
	Type (optional)	-	
Fluid level indicator (light, audible)		Not Available	
Rear window wiper, wiper/washer (std., opt., n.a.)		Not Available	
Horn	Type	Electric Vibration	
	Number used	1	
Other			



.

.



# MVMA Specifications

Vehicle Line Geo PRIZM  
 Model Year 1995 Issued 9/94 Revised (●) \_\_\_\_\_

## METRIC (U.S. Customary)

Engine Code/Description

1.6 LITER L4 (97 CID) MULTI-PORT FUEL INJECTION RPO L01

### Electrical - Supply System

Battery	Manufacturer	Delco Remy
	Model, std., (opt.)	55D 23L
	Voltage	12
	Amps at 0° F. cold crank	356
	Minutes-reserve capacity	99
	Amps/hrs.-20 hr. rate	60
	Location	Left Front of Engine Compartment
Alternator	Manufacturer	DELCO-REMY, Opt: NIPPONDENSO - TENNESSEE
	Rating (idle/max. rpm)	AC 70A
	Ratio (slt. crank/rev.)	2.364
	Output at idle (rpm, park)	-
	Optional (type & rating)	-
Regulator	Type	IC Type

### Electrical - Starting System

Motor	Manufacturer	NIPPONDENSO TENNESSEE
	Current drain _____ °C (°F)	-
	Power rating kw (hp)	1.4
Motor drive	Engagement type	Solenoid Shift
	Pinion engages from (front, rear)	Front

### Electrical - Ignition System

Type	Electronic (std., opt., n.a.)	Standard	
	Other (specify)	Not Applicable	
Coil	Manufacturer	NIPPONDENSO	
	Model	-	
	Current	Engine stopped - A	0 A
		Engine idling - A	0.5 A
Spark plug	Manufacturer	NIPPONDENSO, NGK	
	Model	K16R-U, BKR5EYA	
	Thread (mm)	14 mm (.551 in.)	
	Tightening torque N-m (lb. ft.)	17.6 (23.9)	
	Gap	0.8 mm (.031 in.)	
	Number per cylinder	1	
Distributor	Manufacturer	NIPPONDENSO	
	Model	-	

### Electrical - Suppression

Locations & type	Flame Sprayed Distributor Rotor High Resistance High Tension Cord, High Resistance Spark Plug	Ceramic Distributor Rotor High Resistance High Tension Cord, High Resistance Spark Plug
------------------	---	---



.

.



# MVMA Specifications

Vehicle Line Geo PRIZM  
 Model Year 1995 Issued 9/94 Revised (●) \_\_\_\_\_

## METRIC (U.S. Customary)

Engine Code/Description

1.8 LITER L4 (108 CID) MULTI-PORT FUEL INJECTION RPO LV6

### Electrical - Supply System

Battery	Manufacturer	Delco Remy
	Model, std., (opt.)	55D 23L
	Voltage	12
	Amps at 0° F. cold crank	356
	Minutes-reserve capacity	89
	Amps/hrs.-20 hr. rate	60
	Location	Left Front of Engine Compartment
Alternator	Manufacturer	DELCO-REMY, Opt: NIPPONDENSO - TENNESSEE
	Rating (idle/max. rpm)	AC 70A
	Ratio (alt. crank/rev.)	2.364
	Output at idle (rpm, park)	-
	Optional (type & rating)	-
Regulator	Type	IC Type

### Electrical - Starting System

Motor	Manufacturer	NIPPONDENSO TENNESSEE
	Current drain _____ °C (°F)	-
	Power rating kw (hp)	1.4
Motor drive	Engagement type	Solenoid Shift
	Pinion engages from (front, rear)	Front

### Electrical - Ignition System

Type	Electronic (std., opt., n.a.)	Standard	
	Other (specify)	Not Applicable	
Coil	Manufacturer	NIPPONDENSO	
	Model	-	
	Current	Engine stopped - A	0 A
		Engine idling - A	0.5 A
Spark plug	Manufacturer	NIPPONDENSO, NGK	
	Model	K16R-U, BKR5EYA	
	Thread (mm)	14 mm (.551 in.)	
	Tightening torque N-m (lb. ft.)	17.6 (23.9)	
	Gap	0.8 mm (.031 in.)	
	Number per cylinder	1	
Distributor	Manufacturer	NIPPONDENSO	
	Model	-	

### Electrical - Suppression

Locations & type	Flame Sprayed Distributor Rotor High Resistance High Tension Cord, High Resistance Spark Plug	Ceramic Distributor Rotor High Resistance High Tension Cord, High Resistance Spark Plug
------------------	---	---





.

.



# MVMA Specifications

Vehicle Line Geo PRIZM  
 Model Year 1995 Issued 9/94 Revised (\*) \_\_\_\_\_

## METRIC (U.S. Customary)

Model Code/Description

ALL MODELS

### Body

Structure	Monocoque
Bumper system front - rear	Front: P.P. Facia, Energy Absorber Foam and Reinforcement Rear: Same as Front
Anti-corrosion treatment	Extensive Use of Galvanealed Steel Sheet and Double-Layered Zinc-Iron Alloy Coated Steel Sheet, PVC Sealer, Full Dip Pretreatment Cation ED, PVC Under Coat, Chip Resistant Coat.

### Body - Miscellaneous Information

Type of finish (lacquer, enamel, other)	Enamel	
Hood	Material & mass	Steel, 14.5
	Hinge location (front, rear)	Rear
	Type (counterbalance, prop)	Prop
	Release control (internal, external)	Internal
Trunk lid	Material & mass	Steel, 11.3
	Type (counterbalance, other)	Counterbalance
	Internal release control (elec., mech., n.a.)	Mechanical
Hatchback lid	Material & mass	-
	Type (counterbalance, other)	-
	Internal release control (elec., mech., n.a.)	-
Tailgate	Material & mass	-
	Type (drop, lift, door)	-
	Internal release control (elec., mech., n.a.)	-
Vent window control (crank, friction, pivot, power)	Front	-
	Rear	-
Window regulator type (cable, tape, flex drive, etc.)	Front	Cable
	Rear	Arm & Sector Gear
Seat cushion type (e.g., 60/40 bucket, bench, wire, foam, etc.)	Front	Panel Frame + Spring + Foam Pad
	Rear	Wire Frame + Foam Pad
	3rd seat	-
Seat back type (e.g., 60/40 bucket, bench, wire, foam, etc.)	Front	Pipe Frame + Spring + Foam Pad
	Rear	Wire Frame + Foam pad, Pipe Frame + Panel Frame + Foam Pad (LSI)
	3rd seat	-

### Frame

Type and description (separate frame, unitized frame, partially-unitized frame)	Unitized Frame
---	----------------



.

.



# MVMA Specifications

Vehicle Line Geo PRIZM  
 Model Year 1995 Issued 9/94 Revised (\*) \_\_\_\_\_

## METRIC (U.S. Customary)

Model Code/Description

ALL MODELS

### Restraint System

Seating Position			Left	Center	Right
Active	Type & description (lap & shoulder belt, lap belt, etc.)  Standard / Optional	First seat	3-Point ELR/Standard	Not Applicable	3-Point ALR-ELR/Standard
		Second seat	3-Point ALR-ELR/Standard	2-Point/Standard	3-Point ALR-ELR/Standard
		Third seat	Not Applicable	Not Applicable	Not Applicable
Passive	Type & description (air bag, motorized-2-point belt, fixed belt, knee bolster, manual-lap belt)  Standard / Optional	First seat	Air Bag/Standard	Not Applicable	Air Bag / Standard
		Second seat	Not Applicable	Not Applicable	Not Applicable
		Third seat	Not Applicable	Not Applicable	Not Applicable
<b>Glass</b>		SAE Ref.No.			
Windshield glass exposed surface area cm <sup>2</sup> (in. <sup>2</sup> )		S1	8410 (1303.6)		
Side glass exposed surface area cm <sup>2</sup> (in. <sup>2</sup> ) - total 2 sides		S2	10880 (1686.4)		
Backlight glass exposed surface area cm <sup>2</sup> (in. <sup>2</sup> )		S3	7230 (1120.7)		
Total glass exposed surface area cm <sup>2</sup> (in. <sup>2</sup> )		S4	26520 (4110.6)		
Windshield glass (type/thickness)			Curved-Laminated, 4.7 mm		
Side glass (type/thickness)			Curved-Tempered, 3.5 mm		
Backlight glass (type/thickness)			Curved-Tempered, 3.5 mm		
Tinted (yes/no, location)			Yes		
Solar control (yes/no, coated/batched, location)			Yes		

### Headlamps

Description (sealed beam, halogen, replaceable bulb, etc.)	Replaceable, Halogen
Shape	Aerodynamic-Flush Mounted
Lo-beam type (2A1, 2B1, 2C1, etc.)	Not Applicable
Quantity	2
Hi-beam type (1A1, 2A1, 1C1, 2C1, etc.)	Not Applicable
Quantity	2



.

.

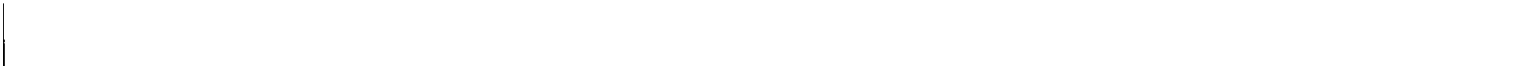

# MVMA Specifications

Vehicle Line Geo PRIZM  
 Model Year 1995 Issued 9/94 Revised (#) \_\_\_\_\_

## METRIC (U.S. Customary)

Engine Code/Description

ALL MODELS

### Climate Control System

Air conditioning (std., opt., man., auto.)		Manual - Optional Automatic - Not Available
Condenser	Type	Corrugated Fin and Serpentine Tube Type
	Eff. face area (sq. mm.)	239414
	Fins per inch	Pitch = 3.6 mm
Evaporator	Type	Drawn Cup Type
	Eff. face area (sq. mm.)	52250
	Fins per inch	Pitch = 4.0 mm
Heater core	Material	Copper - Brass
	Eff. face area (sq. mm.)	30690
	Fins per inch	Pitch = 1.8 mm
Compressor	Type	10 PA 15
	Displacement (cc.)	155.3
	Manufacturer	NIPPONDENSO (U.S.A)
	A/C pulley ratio	0.93
Accumulator	Type	-
	Height (mm.)	-
	Diameter (mm.)	-
Receiver	Type	Normal
	Height (mm.)	187 mm
	Diameter (mm.)	48 mm
Refrigerant control (COOT, TVS, etc.)		-
Heater water valve (yes / no)		Yes
Refrigerant (R - 12, R - 134a, etc.)		R-134a
Charge level (lbs. - oz.)		700 ± 50 g.
Cold engine lockout switch (yes / no)		-
Wide open throttle cutout switch (yes / no)		-

---

---

# MVMA Specifications

Vehicle Line Geo PRIZM  
 Model Year 1995 Issued 9/94 Revised (\*) \_\_\_\_\_

## METRIC (U.S. Customary)

Model Code/Description

ALL

### Convenience Equipment (standard, optional, n.a.)

	Clock (digital, analog)	With Radio, Optional
	Compass / thermometer	Not Available
	Console (floor, overhead)	Floor
	Defroster, electric windshield	Standard
	Defroster, electric backlight	Optional
Electronic	Diagnostic monitor (integrated, individual)	Not Available
	Instrument cluster (list instruments)	Not Available
	Keyless entry	-
	Trip/finder (avg. spd., fuel)	-
	Voice alert (list items)	-
	Other	-
	Fuel door lock (remote, key, electric)	Remote
Integrated Child Seating	Std./opt. & location in vehicle	
	Number of occupants	
	Occupant weight/height (min. & max.)	
	Restraint system description (3 or 5-point belts/booster seat capability)	
Lamps	Auto head on/off delay, dimming	Not Available
	Cornering	-
	Courtesy (map, reading)	Without Map Lamp, Standard; With Map Lamp, Optional
	Door lock, ignition	Not Available
	Engine compartment	-
	Fog	-
	Glove compartment	-
	Trunk	Without Trunk Lamp, Standard; With Trunk Lamp, Optional
	Illuminated entry system (list lamps, activation)	Not Available
	Other	-
Mirrors	Day / night (auto., man.)	
	L.H. (remote, power, heated)	Standard, Remote; Optional, Power
	R.H. (convex, remote, power, heated)	Standard, Not Available; Optional, Convex Fix, Convex Power
	Visor vanity (RH / LH, illuminated)	-
	Navigation system (describe)	Not Available
	Parking brake-auto release (warning light)	Not Available





2

2



# MVMA Specifications

Vehicle Line Geo PRIZM  
 Model Year 1995 Issued 9/94 Revised (#) \_\_\_\_\_

## METRIC (U.S. Customary)

Model Code/Description

ALL MODELS

### Convenience Equipment (standard, optional, n.a.)

Power equipment	Deck lid (release, pull down)		Not Available
	Door locks (manual, automatic, describe system)		Optional (Manual)
	Seats	2 - 4 - 6 way, etc.	Not Available
		Reclining (R.H., L.H.)	"
		Memory (R.H., L.H., preset recline)	"
		Support (tumbler, hip, thigh, etc.)	"
		Heated (R.H., L.H., other)	"
	Side windows		Optional
	Vent windows		Not Available
	Rear windows		"
Radio systems	Antenna (location, whip, w/shield, power)		Roof
	Standard	AM, FM, stereo, tape, compact disc, graphic equalizer, theft deterrent, radio prep package, headphone jacks, etc.	Radioless
	Optional		AM/FM MPX ETR AM/FM MPX ETR, with Cassette Deck AM/FM MPX ETR, with Cassette, CD
	Speaker (number, location)		Std. - 2, Front Doors; Opt. - 4, Front Doors + Rear Package Tray Opt. - 6, 4 + Outside Mirror Brackets.
	Roof: open air or fixed (flip-up, sliding, "T")		Optional, Sliding / Flip-Up
Speed control device		Optional	
Speed warning device (light, buzzer, etc.)		Not Available	
Tachometer (rpm)		8000	
Telephone system (describe)		Not Available	
Theft deterrent system		Not Available	

### Trailer Towing

Towing capable	Yes / No	Yes
Engine / transmission / axle	Std. / Opt.	No
Tow class (I, II, III)*	Std. / Opt.	1 (1500 lbs.)
Max. gross trailer wgt. (lbs.)	Std. / Opt.	1500
Max. trailer tongue load (lbs.)	Std. / Opt.	150
Towing package available	Yes / No	No

\* Class I - 2,000 lbs.    Class II - 3,500 lbs.    Class III - 5,000 lbs.



1  
2



# MVMA Specifications

Vehicle Line Geo PRIZM  
 Model Year 1995 Issued 9/94 Revised (\*) \_\_\_\_\_

## METRIC (U.S. Customary)

### Vehicle Dimensions See Key Sheets for definitions

All dimensions to ground are for comparative purposes only. Dimensions are to be shown for all base body models of each vehicle line. SAE Ref. no. refers to the definition published in SAE Recommended Practice J1100 "Motor Vehicle Dimensions," unless otherwise specified.

Model Code/Description	SAE Ref. No.	ALL MODELS
<b>Width</b>		
Tread (front)	W101	1460 (57.5)
Tread (rear)	W102	1450 (57.1)
Vehicle width	W103	1685 (66.3)
Body width at SgRP (front)	W117	1677 (66.0)
Vehicle width (front doors open)	W120	3363 (132.4)
Vehicle width (rear doors open)	W121	3356 (132.1)
Tumble-home (degrees)	W122	24
Outside mirror width	W410	928.6 (36.6), LH; 1865.9 (73.5), RH

### Length

Wheelbase	L101	2465 (97.0)
Vehicle length	L103	4395 (173.0)
Overhang (front)	L104	885 (34.8)
Overhang (rear)	L105	1045 (41.1)
Upper structure length	L123	2660 (104.7)
Rear Wheel C/L "X" coordinate	L127	2465 (97.0)

### Height \*\*

Passenger distribution (front/rear)	PD1,2,3		**
Trunk/cargo load			**
Vehicle height	H101	1355 (53.3)	
Cowl point to ground	H114	880 (34.6)	
Deck point to ground	H138	1010 (39.8)	
Rocker panel-front to ground	H112	180 (7.1)	
Rocker panel-rear to ground	H111	200 (7.9)	
Windshield slope angle (degrees)	H122	30.5	
Backlight slope angle (degrees)	H121	25.5	

### Ground Clearance \*\*

Front bumper to ground	H102	175 (6.9)
Rear bumper to ground	H104	230 (9.1)
Bumper to ground front at curb mass (wt.)	H103	210 (8.3)
Bumper to ground rear at curb mass (wt.)	H105	250 (9.8)
Angle of approach (degrees)	H106	17.0
Angle of departure (degrees)	H107	16.0
Ramp breakover angle (degrees)	H147	14.0
Axle differential to ground (front/rear)	H153	140 (5.5) Front
Min. running ground clearance	H156	120 (4.7)
Location of min. running ground clear.		Front Lower Arm Bracket

\*\* All Vehicle Height And Ground Clearance Are Made Using EPA Loaded Vehicle Weight, Loading Conditions. EPA loaded vehicle weight is the base vehicle weight plus all coolant and fluids necessary for operation plus 100% of the fuel capacity, plus the weight of all options and accessories which weigh three pounds or more and which are sold on at least 33% of the car line, plus two occupants.

All linear dimensions are in millimeters (inches).



1  
2



# MVMA Specifications

Vehicle Line Geo PRIZM  
 Model Year 1995 Issued 9/94 Revised (●) \_\_\_\_\_

## METRIC (U.S. Customary)

Vehicle Dimensions See Key Sheets for definitions

Model Code/Description	SAE Ref. No.	ALL MODELS
------------------------	--------------	------------

### Front Compartment

SgRP front, "X" coordinate	L31	1340 (52.8)
Effective head room	H61	977.4 (38.5); With Sunroof - 838.5 (36.9)
Max. effective leg room (accelerator)	L34	1059.6 (41.7)
SgRP to heel point	H30	259.9 (10.2)
SgRP to heel point	L53	877.2 (34.5)
Back angle (degrees)	L40	250
Hip angle (degrees)	L42	97.9
Knee angle (degrees)	L44	128.4
Foot angle (degrees)	L46	80.5
Design H-point front travel	L17	239.1 (9.4)
Normal driving & riding seat track trvl.	L23	239.1 (9.4)
Shoulder room	W3	1374 (54.1)
Hip room	W5	1303.7 (51.3)
*** Upper body opening to ground	H50	1225.7 (48.3)
Steering wheel maximum diameter*	W9	380 (15.0)
Steering wheel angle (degrees)	H18	25 deg. 09'
Accel. heel pt. to steer. whl. cntr.	L11	420.9 (16.6)
Accel. heel pt. to steer. whl. cntr.	H17	651.4 (25.6)
Undepressed floor covering thickness	H67	23.5 (.925)

Front Compartment Interior Dimensions are Measured with the Seating Reference Point (SgRP) \_\_\_\_\_ mm forward and \_\_\_\_\_ mm Upward of Rearmost Position.

### Rear Compartment

SgRP point couple distance	L50	730 (28.7)
Effective head room	H63	924.4 (36.4); With Sunroof - 909.2 (35.8)
Min. effective leg room	L51	839.7 (33.1)
SgRP (second to heel)	H31	301.8 (11.9)
Knee clearance	L48	-45.6 (-1.8)
Shoulder room	W4	1355.4 (53.4)
Hip room	W6	1378 (54.3)
*** Upper body opening to ground	H51	1237.3 (48.7)
Back angle (degrees)	L41	27
Hip angle (degrees)	L43	85
Knee angle (degrees)	L45	79
Foot angle (degrees)	L47	111
Depressed floor covering thickness	H73	5.9 (.232)

### Luggage Compartment

*** Usable luggage capacity L (cu. ft.)	V1	359 (12.68)
Liftover height	H195	670 (26.4)

### Interior Volumes (EPA Classification)

Vehicle class	Compact Car
Interior volume index including trunk/cargo (cu. ft.)**	101.0
Trunk/cargo index (cu. ft.)	12.7

\* See page 14.

\*\* See definition page 33.

All linear dimensions are in millimeters (inches) unless otherwise noted.

\*\*\* EPA Loaded Vehicle Weight, Loading Conditions



# MVMA Specifications

Vehicle Line Geo PRIZM  
 Model Year 1995 Issued 9/94 Revised (●) \_\_\_\_\_

## METRIC (U.S. Customary)

Vehicle Dimensions See Key Sheets for definitions

Model Code/Description

4-DOOR NOTCHBACK

Station Wagon/MPV\*  
 -Third Seat

SAE  
 Ref.  
 No.

Not Applicable

Seat facing direction	SD1	
SgRP couple distance	L85	
Shoulder room	W85	
Hip room	W86	
Effective leg room	L86	
Effective head room	H86	
SgRP to heel point	H87	
Knee clearance	L87	
Back angle (degrees)	L88	
Hip angle (degrees)	L89	
Knee angle (degrees)	L90	
Foot angle (degrees)	L91	

Station Wagon/MPV\* - Cargo Space

Not Applicable

Cargo length (open front)	L200	
Cargo length (open second)	L201	
Cargo length (closed front)	L202	
Cargo length (closed second)	L203	
Cargo length at belt (front)	L204	
Cargo length at belt (second)	L205	
Cargo width (wheelhouse)	W201	
Rear opening width at floor	W203	
Opening width at belt	W204	
Min. rear opening width above belt	W205	
Cargo height	H201	
Rear opening height	H202	
Tailgate to ground height	H250	
Front seat back to load floor height	H197	
Cargo volume index m <sup>3</sup> (ft. <sup>3</sup> )	V2	
Hidden cargo volume index m <sup>3</sup> (ft. <sup>3</sup> )	V4	
Cargo volume index-rear of 2-seat	V10	
Cargo volume index*	V6	
Cargo width at floor*	W500	
Maximum cargo height*	H505	

Hatchback - Cargo Space

Not Applicable

Cargo length at front seatback height	L208	
Cargo length at floor (front)	L209	
Cargo length at second seatback height	L210	
Cargo length at floor (second)	L211	
Front seatback to load floor height	H197	
Second seatback to load floor height	H198	
Cargo volume index m <sup>3</sup> (ft. <sup>3</sup> )	V3	
Hidden cargo volume index m <sup>3</sup> (ft. <sup>3</sup> )	V4	
Cargo volume index - rear of 2-seat	V11	

All linear dimensions are in millimeters (inches) unless otherwise noted.

\* MPV - Multipurpose Vehicle

\*\* EPA Loaded Vehicle Weight, Loading Conditions





# MVMA Specifications

Vehicle Line Geo PRIZM  
 Model Year 1995 Issued 9/94 Revised (●) \_\_\_\_\_

METRIC (U.S. Customary)

Model Code/ Description	ALL MODELS
----------------------------	------------

## Vehicle Fiducial Marks

Fiducial Mark Number*	Define Coordinate Location	
Front	Center of Outer Installation Hole for Seat Truck of Front Floor Crossmember (both sides)	
Rear	Center of Seat Belt Anchorage Hole in Center Floor	
NOTE: Provide 3 of 4 Fiducial Mark Locations		
Front	W21**	W5 + 81.5 mm
	L54**	L19 + 80.6 mm
	H81**	H10 + 75.4 mm
	H161***	295 mm (11.6 in.)
	H163***	270 mm (10.6 in.)
Rear	W22**	W1 + 90 mm
	L55**	L32 + 10 mm
	H82**	H11 + 45 mm
	H162***	375 mm (14.8 in.)
	H164***	350 mm (13.8 in.)

\* Reference - SAE Recommended Practice, J182a, Motor Vehicle Fiducial Marks.  
 \*\* Reference - SAE Recommended Practice J1100 - Motor Vehicle Dimensions.  
 \*\*\* EPA Loaded Vehicle Weight, Loading Conditions  
 All linear dimensions are in millimeters (inches) unless otherwise noted.



2

3



# MVMA Specifications

## METRIC (U.S. Customary)

Vehicle Line Geo PRIZM  
 Model Year 1995 Issued 9/94 Revised (\*)

		VEHICLE MASS (WEIGHT)					% PASS MASS DISTRIBUTION			
Code	Model	CURB MASS, kg. (lb.)*			Shipping Mass kg (lb)**	ETWC** Code	Pass in Front		Pass in Rear	
		Front	Rear	Total			Front	Rear	Front	Rear
Geo PRIZM	1SK19	640	430	1070	1038	O	50	50	16	84
4-Door Notchback Sedan	L01, M/T	(1411)	(948)	(2359)	(2288)					
Geo PRIZM	1SK19	660	430	1090	1058	O	50	50	16	84
4-Door Notchback Sedan	L01, A/T	(1455)	(948)	(2403)	(2332)					
Geo PRIZM LSi	1SK19	645	430	1075	1043	O	50	50	16	84
4-Door Notchback Sedan	LV6, M/T	(1422)	(948)	(2370)	(2299)					
Geo PRIZM LSi	1SK19	675	430	1105	1073	P	50	50	16	84
4-Door Notchback Sedan	LV6, A/T	(1488)	(948)	(2436)	(2365)					

\* Reference - SAE J1100 Motor vehicle dimensions, curb weight definition.  
 \*\* ETWC - Equivalent Test Weight Class - basis for U.S. Environmental Protection Agency emission certifications.  
 Refer to ETWC code legend below for test weight class.

- ETWC LEGEND
- |          |          |          |           |
|----------|----------|----------|-----------|
| A = 1000 | I = 2000 | Q = 3000 | Y = 4000  |
| B = 1125 | J = 2125 | R = 3125 | Z = 4250  |
| C = 1250 | K = 2250 | S = 3250 | AA = 4500 |
| D = 1375 | L = 2375 | T = 3375 | BB = 4750 |
| E = 1500 | M = 2500 | U = 3500 | CC = 5000 |
| F = 1625 | N = 2625 | V = 3625 | DD = 5250 |
| G = 1750 | O = 2750 | W = 3750 | EE = 5500 |
| H = 1875 | P = 2875 | X = 3875 | FF = 5750 |

\*\*\* Shipping Mass (weight) = Curb Weight Less:  
 32 (71)

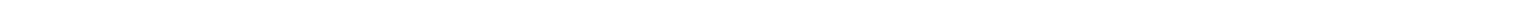

**MVMA Specifications**  
**METRIC (U.S. Customary)**

Vehicle Line Geo PRIZM  
Model Year 1995 Issued 9/94 Revised (●) \_\_\_\_\_

Code	Equipment	Optional Equipment Differential Mass (weight)*			Remarks Restrictions, Requirements
		MASS, kg. (lb.)			
		Front	Rear	Total	
	Air Conditioning	21.1 (46.5)	0 (0)	21.1 (46.5)	
	Power Steering	9.5 (20.9)	0 (0)	9.5 (20.9)	
	Radio	4.4 (9.7)	.8 (1.8)	5.2 (11.5)	
	Door Mirror	1.6 (3.5)	.4 (.9)	2.0 (4.4)	
	ABS	7.7 (17.0)	0 (0)	7.7 (7.7)	
	Tilt Steering	2.1 (4.6)	0 (0)	2.1 (4.6)	
	Power Window	1.5 (3.3)	2.2 (4.9)	3.7 (8.2)	
	Electrical Door Dock	.3 (.7)	.5 (1.1)	.8 (1.8)	
	Sun Roof	6.0 (13.2)	8.0 (17.6)	14.0 (30.8)	
	Cruise Control	2.5 (5.5)	0 (0)	2.5 (5.5)	
	LSi Grade Package	.9 (2.0)	12.5 (27.5)	13.4 (29.5)	

\* Also see Engine - General Section for dressed engine mass (weight.)

---

.

3

---

# MVMA Specifications

METRIC (U.S. Customary)

## Exterior Vehicle And Body Dimensions – Key Sheet

### Exterior Width

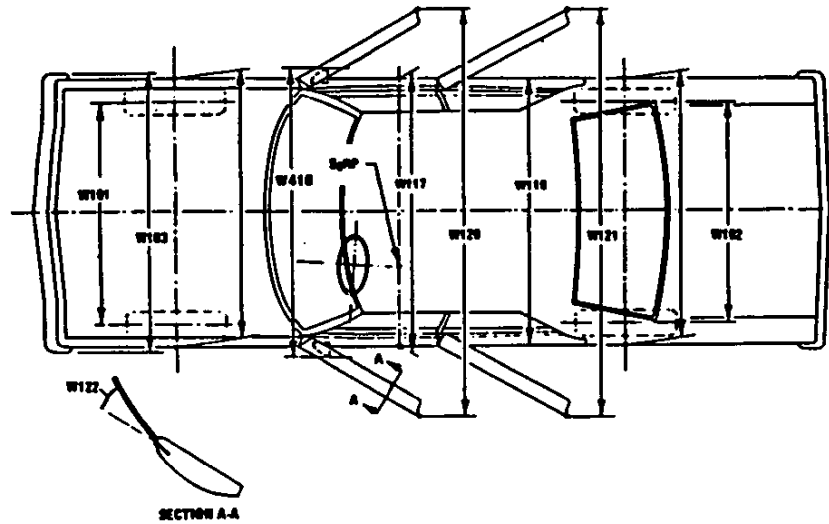

### Exterior Length & Height

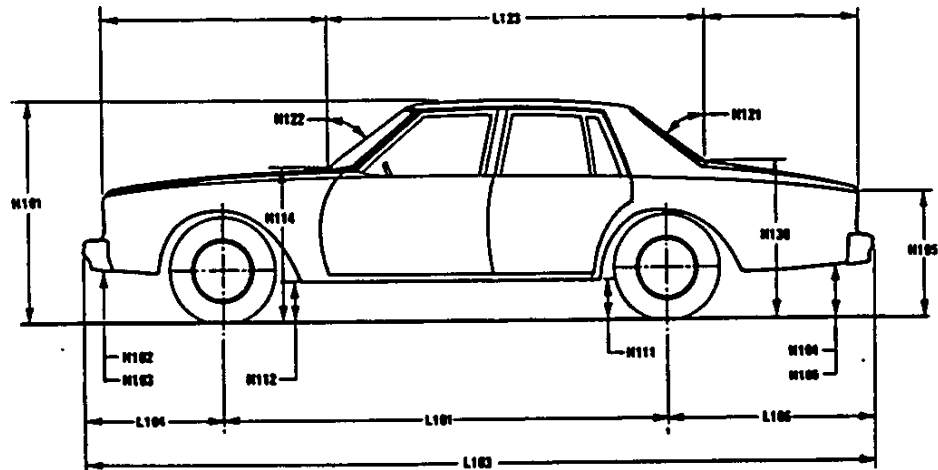

### Exterior Ground Clearance

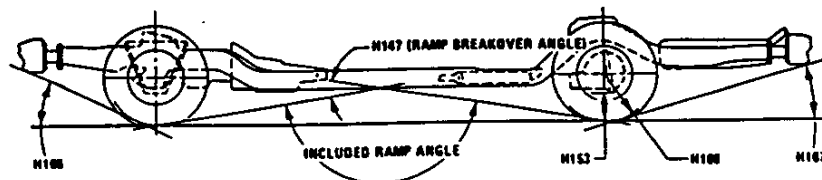



---

.

2

---

# MVMA Specifications Form

## METRIC (U.S. Customary)

### Interior Vehicle And Body Dimensions - Key Sheet

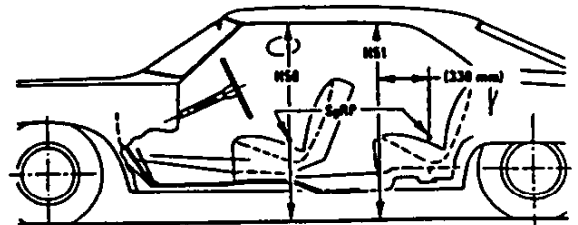
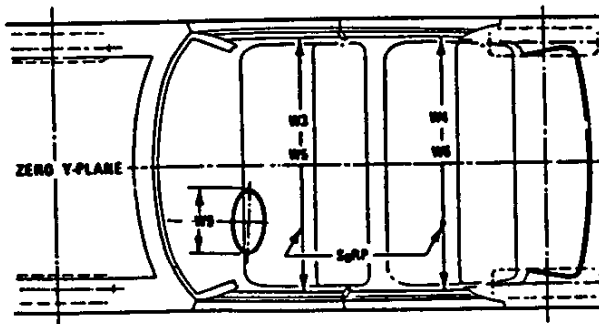
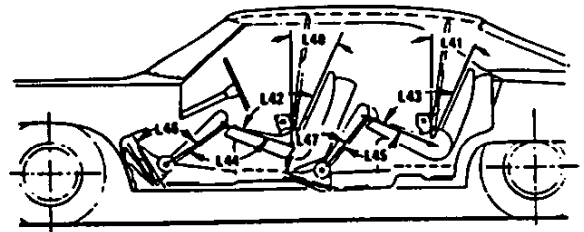
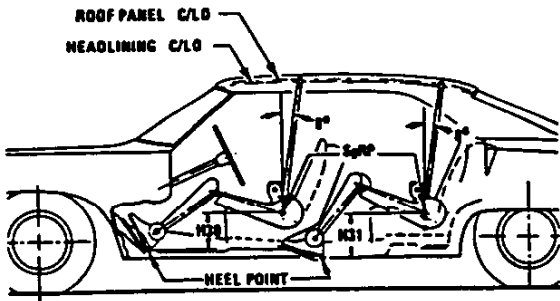
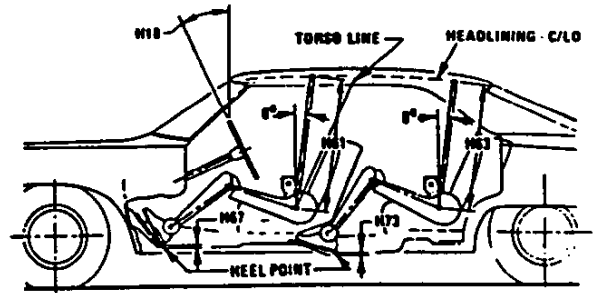
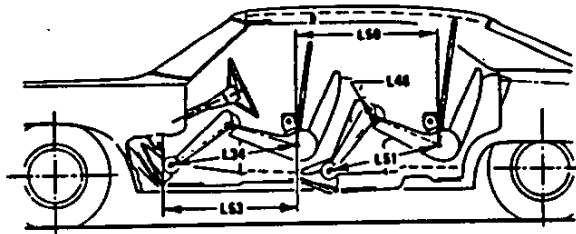

---

.

.

.

---

**MVMA Specifications**  
**METRIC (U.S. Customary)**

**Interior Vehicle And Body Dimensions – Key Sheet**

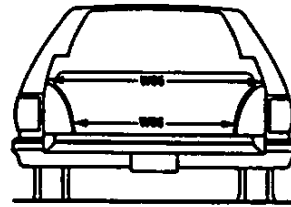
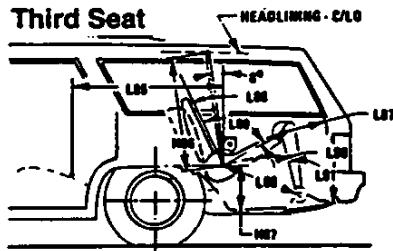

**Cargo Space**

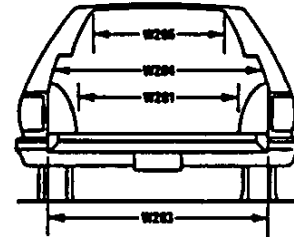
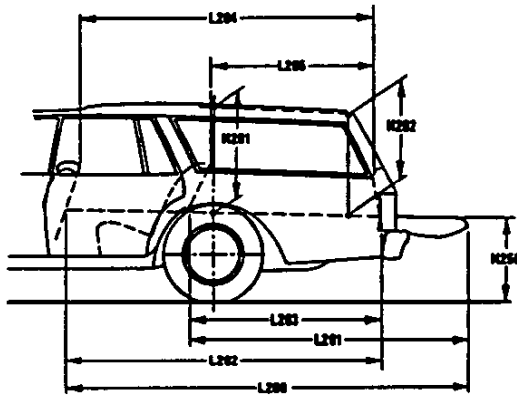

**Station Wagon**

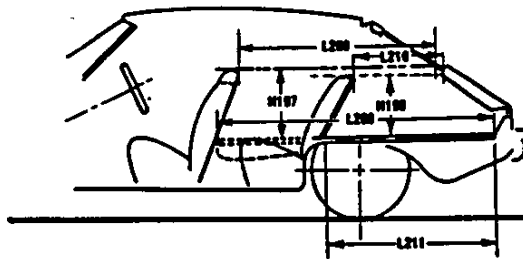

**Hatchback**

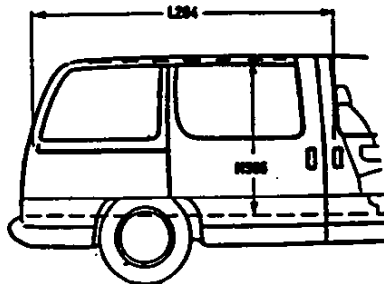

**Multipurpose Vehicle**



# MVMA Specifications

## METRIC (U.S. Customary)

### Exterior Vehicle And Body Dimensions – Key Sheet Dimensions Definitions

#### Seating Reference Point

SEATING REFERENCE POINT means the manufacturer's design reference point which –

- (a) Establishes the rearmost normal design driving or riding position of each designated seating position in a vehicle;
- (b) Has coordinates established relative to the design vehicle structure;
- (c) Simulates the position of the pivot center of the human torso and thigh; and
- (d) Is the reference point employed to position the two dimensional templates described in SAE Recommended Practice J826, "Devices for Use in Defining and Measuring Vehicle Seating Accommodations."

#### Width Dimensions

- W101 TREAD – FRONT. The dimension measured between the tire centerlines at the ground.
- W102 TREAD – REAR. The dimension measured between the tire centerlines at the ground. In case of dual wheels, the dimension will be measured to the centerline of tire and wheel assemblies.
- W103 VEHICLE WIDTH. The maximum dimension measured between the widest point on the vehicle, excluding exterior mirrors, flexible mud flaps, marker lamps, but including bumpers, moldings, sheet metal protrusions or dual wheels, if standard equipment.
- W117 BODY WIDTH AT SgRP – FRONT. The dimension measured laterally between the widest points on the body at the SgRP-front, excluding door handles, applied moldings, or appliques.
- W120 VEHICLE WIDTH – FRONT DOORS OPEN. The dimension measured between the widest point on the front doors in maximum hold-open position.
- W121 VEHICLE WIDTH – REAR DOORS OPEN. The dimension measured between the widest point on the rear doors in maximum hold-open position. For vehicles with a rear door on only one side, this dimension is to the zero "Y" plane.
- W122 TUMBLE – HOME. STRAIGHT SIDE GLASS. The angle measured from a vertical to the outside surface of the front door glass at the SgRP "X" plane.  
CURVED SIDE GLASS. The angle measured from a vertical to a chord extending from the upper DLO to the lower DLO at the outside surface of the front door glass at the front SgRP "X" plane.
- W410 OUTSIDE MIRROR WIDTH: The dimension between the widest point on the outside mirrors. The standard right and left mirror adjusted for normal driving will be shown unless otherwise noted. When only one outside mirror is standard, the dimension will be to the zero "Y" plane.

#### Length Dimensions

- L101 WHEELBASE (WB). The dimension measured longitudinally between front and rear wheel centerlines. In case of dual rear axles, the dimension shall be to the midpoint of the centerlines of the rear wheels.
- L103 VEHICLE LENGTH. The maximum dimension measured longitudinally between the foremost point and the rearmost point on the vehicle, including bumper, bumper guards, tow hooks and/or rub strips, if standard equipment.
- L104 OVERHAND – FRONT. The dimension measured longitudinally from the centerline of the front wheels to the foremost point on the vehicle including bumper, bumper guards, tow hooks and/or rub strips, if standard equipment.
- L105 OVERHANG – REAR. The dimension measured longitudinally from the centerline of the rear wheels; or in the case of dual rear axles, the dimension shall be the midpoint of the centerlines of the rear wheels, to the rearmost point on the vehicle including rear bumpers, bumper guards, tow hooks and rub strips, if standard equipment.

- L123 UPPER STRUCTURE LENGTH. The dimension measured longitudinally from the cowl point to the deck point.
- L127 REAR WHEEL CENTERLINE "X" COORDINATE or in the case of dual rear axles, the coordinate shall be the midpoint of the distance between the rear axle centerlines.

#### Height Dimensions

- H101 VEHICLE HEIGHT. The dimension measured vertically from the highest point on the vehicle body to ground.
- H111 ROCKER PANEL – REAR TO GROUND. The dimension measured vertically from the bottom of the rocker or side quarter panel at the front of the rear wheel opening, excluding flanges, to ground.
- H112 ROCKER PANEL – FRONT TO GROUND. The dimension measured vertically from the foremost point on the bottom of the rocker panels, excluding flanges, to ground.
- H114 COWL POINT TO GROUND. Measured at zero "Y" plane.
- H121 BACKLIGHT SLOPE ANGLE. The angle between the vertical reference line and the surface of backlight at vehicle zero "Y" plane. For curve backlight, the angle is to chord of backlight arc from lower DLO to upper DLO.
- H122 WINDSHIELD SLOPE ANGLE. The angle between the vertical reference line and a chord of the windshield arc running from the lower DLO to the upper DLO at the vehicle zero "Y" plane. In the case of wrap over glass, the angle to be measured will be formed by a chord 457 mm (18.0 in.) long drawn from the lower DLO to the intersecting point on the windshield.
- H138 DECK POINT TO GROUND. Measured at zero "Y" plane.
- H109 STATIC LOAD – TIRE RADIUS – REAR. Specified by the manufacturer in accordance with composite TIRE SECTION STANDARD.

#### Ground Clearance Dimensions

- H102 FRONT BUMPER TO GROUND. The minimum dimension measured vertically from the lowest point on the front bumper to ground, including bumper guards, if standard equipment.
- H103 FRONT BUMPER TO GROUND – CURB MASS (WT.). Measured in the same manner as H102.
- H104 REAR BUMPER TO GROUND. The minimum dimension measured vertically from the lowest point on the rear bumper to ground, including bumper guards, if standard equipment.
- H105 REAR BUMPER TO GROUND – CURB MASS (WT.). Measured in the same manner as H104.
- H106 ANGLE OF APPROACH. The angle measured between a line tangent to the front tire static loaded radius arc and the initial point of structural interference forward of the front tire to ground. The limiting structural component shall be designated.
- H107 ANGLE OF DEPARTURE. The angle measured between a line tangent to the rear tire static loaded radius arc and the initial point of structural interference rearward of the rear tire to ground. The limiting component shall be designated.
- H147 RAMP BREAKOVER ANGLE. The angle measured between two lines tangent to the front and rear tire static loaded radius and intersecting at a point on the underside of the vehicle which defines the largest ramp over which the vehicle can roll.
- H153 REAR AXLE DIFFERENTIAL TO GROUND. The minimum dimension measured from the rear axle differential to ground.
- H156 MINIMUM RUNNING GROUND CLEARANCE. The minimum dimension measured from the sprung vehicle to ground. Specify location.



# MVMA Specifications

## METRIC (U.S. Customary)

### Interior Vehicle And Body Dimensions – Key Sheet Dimensions Definitions

#### Glass Areas

- S1 Windshield area.  
S2 Side windows area. Includes the front door, rear door, vents, and rear quarter windows on both sides of the vehicle.  
S3 Backlight areas.  
S4 Total area. Total of all areas (S1 + S2 + S3).

#### Fiducial Mark Dimensions

- Fiducial Mark – Number 1**  
L54 "X" coordinate.  
W21 "Y" coordinate.  
H81 "Z" coordinate.  
H161 Height "Z" coordinate to ground at curb weight.  
H163 Height "Z" coordinate to ground.  
**Fiducial Mark – Number 2**  
L55 "X" coordinate.  
W22 "Y" coordinate.  
W82 "Z" coordinate.  
H162 Height "Z" coordinate to ground at curb weight.  
H164 Height "Z" coordinate to ground.

#### Front Compartment Dimensions

- L11 ACCELERATOR HEEL POINT TO STEERING WHEEL CENTER. The dimension measured horizontally from the AHP to the intersection of the steering column centerline and a plane tangent to the upper surface of the steering wheel rim.  
L17 DESIGN H-POINT – FRONT TRAVEL. The dimension measured horizontally between the design H-point – front in the foremost and rearmost seat track positions. (See SAE J1100)  
L23 NORMAL DRIVING AND RIDING SEAT TRACK TRAVEL. The dimension measured horizontally between a point on the design H-point travel line from the SgRP to the displaced point on the design H-point travel line with the seat moved to the foremost seat position, but not to include seat track travel used for purposes other than normal driving and riding positions. (See SAE J1100).  
L31 SgRP – FRONT. "X" COORDINATED.  
L34 MAXIMUM EFFECTIVE LEG ROOM – ACCELERATOR. The dimension measured along a line from the ankle pivot center to the SgRP – front plus 254 mm (10.0 in.) measured with right foot on the undepressed accelerator pedal. For vehicles with SgRP to heel (H30) greater than 18 in., the accelerator pedal may be depressed as specified by the manufacturer. If the accelerator is depressed, the manufacturer shall place foot flat on pedal and note the depression of the pedal.  
L-40 BACK ANGLE – FRONT. The angle measured between a vertical line through the SgRP – front and the torso line. If the seatback is adjustable, use the normal driving and riding position specified by the manufacturer.  
L-42 HIP ANGLE – FRONT. The angle measured between torso line and thigh centerline.  
L44 KNEE ANGLE – FRONT. The angle measured between thigh centerline and lower leg centerline measured on the right leg.  
L46 FOOT ANGLE – FRONT. The angle measured between the lower leg centerline and a line tangent to the ball and heel of the bare foot flesh line measured on the right leg. Ref SAE J826.  
L53 SgRP – FRONT TO HEEL. The dimension measured horizontally from the SgRP – front to the accelerator heel point.  
W3 SHOULDER ROOM – FRONT. The minimum dimension measured laterally between the trimmed surfaces on the "X" plane through the SgRP – front at height between the belt line and 254 mm (10.0 in.) above the SgRP – front, excluding the door assist strap and attaching parts.

- W5 HIP ROOM – FRONT. The minimum dimension measured laterally between the trimmed surfaces on the "X" plane through the SgRP – front within 25 mm (1.0 in.) below and 76 mm (3.0 in.) above the SgRP – front and 76 mm (3.0 in.) fore and aft of the SgRP – front.  
W9 STEERING WHEEL MAXIMUM OUTSIDE DIAMETER. Define if other than round.  
H7 ACCELERATOR HEEL POINT TO THE STEERING WHEEL CENTER. The dimension measured vertically from the AHP – front to the intersection of the steering column centerline to a plane tangent to the upper surface of the steering wheel rim.  
H18 STEERING WHEEL ANGLE. The angle measured from a vertical to the surface plane of the steering wheel.  
H30 SgRP – FRONT TO HEEL. The dimension measured vertically from the SgRP – front to the accelerator heel point.  
H50 UPPER BODY OPENING TO GROUND – FRONT. The dimension measured vertically from the trimmed body opening to the ground on the SgRP – front "X" plane.  
H61 EFFECTIVE HEAD ROOM – FRONT. The dimension measured along a line 8 deg. rear of vertical from the SgRP – front to the headlining plus 102 mm (4.0 in.).  
H67 FLOOR COVERING THICKNESS – UNDEPRESSED – FRONT. The dimension measured vertically from the surface of the undepressed floor covering to the underbody sheet metal at the accelerator heel point.

#### Rear Compartment Dimensions

- L-41 BACK ANGLE – SECOND. The angle measured between a vertical line through the SgRP – second and the torso line.  
L43 HIP ANGLE – SECOND. The angle measured between torso line and thigh centerline.  
L45 KNEE ANGLE – SECOND. The angle measured between thigh centerline and lower leg centerline.  
L47 FOOT ANGLE – SECOND. The angle measured between the lower leg centerline and a line tangent to the ball and heel of the three-dimensional devices bare foot flesh line (Reference J826).  
L48 KNEE CLEARANCE – SECOND. The minimum dimension measured from the knee pivot center to the back of the front seatback minus 51 mm (2.0 in.).  
L50 SgRP COUPLE DISTANCE – SECOND. The dimension measured horizontally from the driver SgRP – front to the SgRP – second.  
L51 MINIMUM EFFECTIVE LEG ROOM – SECOND. The dimension measured along a line from the ankle pivot center to the SgRP – second plus 254 mm (10.0 in.).  
W4 SHOULDER ROOM – SECOND. The minimum dimension measured laterally between door or quarter trimmed surfaces on the "X" plane through the SgRP – second at height between 254-406 mm (10.0-16.0 in.) above the SgRP – second, excluding the door assist straps and attaching parts.  
W6 HIP ROOM – SECOND. Measured in the same manner as W5.  
H31 SgRP – SECOND TO HEEL. The dimension measured vertically from the SgRP – second to the two dimensional device heel point on the depressed floor covering.  
H51 UPPER BODY OPENING TO GROUND – SECOND. The dimension measured vertically from the trimmed body opening to the ground on the "X" plane 330 mm (13.0 in.) forward of the SgRP – second.  
H63 EFFECTIVE HEAD ROOM – SECOND. The dimension measured along a line 8 deg. rear of vertical from the SgRP to the headlining, plus 102 mm (4.0 in.).  
H73 FLOOR COVERING – DEPRESSED – SECOND. The dimension measured vertically from the heel point to the underbody sheet metal.



\_\_\_\_\_

•

•

\_\_\_\_\_

\_\_\_\_\_

# MVMA Specifications

## METRIC (U.S. Customary)

### Interior Vehicle And Body Dimensions – Key Sheet Dimensions Definitions

#### Luggage Compartment Dimensions

- V1 USABLE LUGGAGE CAPACITY – Total of volumes of individual pieces of standard luggage set plus H-boxes stowed in the luggage compartment in accordance with the procedure described in paragraph 8.2 of SAE-J1100a.

#### Interior Volumes (EPA Classification)

The Interior Volume Index is listed for each body style except two seaters. The Interior Volume Index estimates the space in a car. It is based on four measurements – head room, shoulder room, hip room, and leg room – for the front and rear seats, plus trunk capacity.

The Trunk/Cargo Index is an estimate of the size of the trunk/cargo space. In station wagons and hatchbacks it is an estimate of the space behind the second seat.

#### Station Wagon / MPV – Third Seat Dimensions

- L85 SgRP COUPLE DISTANCE – THIRD. The dimension measured horizontally from the SgRP – second to the SgRP – third.
- L86 EFFECTIVE LEG ROOM – THIRD. The dimension measured along a line from the ankle pivot center to the SgRP – third plus 254 mm (10.0 in.).
- L87 KNEE CLEARANCE – THIRD. The minimum dimension from the knee pivot center to the back of second seatback minus a constant of 51 mm (2.0 in.). With rear-facing third seat, dimension is measured to closure.
- L88 BACK ANGLE – THIRD. Measured in the same manner as L41.
- L89 HIP ANGLE – THIRD. Measured in the same manner as L43.
- L90 KNEE ANGLE – THIRD. Measured in the same manner as L45.
- L91 FOOT ANGLE – THIRD. Measured in the same manner as L47.
- W85 SHOULDER ROOM – THIRD. Measured in the same manner as W4.
- W86 HIP ROOM – THIRD. Measured in the same manner as W5.
- H86 EFFECTIVE HEAD ROOM – THIRD. The dimension, measured along a line 8 deg. from the SgRP – third to the headlining rear of vertical plus a constant of 102 mm (4.0 in.).
- H87 SgRP – THIRD TO HEEL POINT.
- SD1 SEAT FACING DIRECTION – THIRD.

#### Station Wagon / MPV – Cargo Space Dimensions

- L200 CARGO LENGTH – OPEN – FRONT. The minimum dimension measured longitudinally from the back of the front seatback at the height of the undepressed floor covering to the rearmost point on the undepressed floor covering on the open tailgate or cargo surface if the rear closure is a conventional door type tailgate at the zero "Y" plane.
- L201 CARGO LENGTH – OPEN – SECOND. The dimension measured longitudinally from the back of the second seatback at the height of the undepressed floor covering to the rearmost point on the undepressed floor covering on the open tailgate or cargo floor surface if the rear closure is a conventional door type tailgate, at the zero "Y" plane.
- L202 CARGO LENGTH – CLOSED – FRONT. The minimum dimension measured horizontally from the back of the front seat at the height of the undepressed floor covering to the rearmost point on the undepressed floor covering on the closed tailgate or taildoor for station wagons, trucks and mpv's at the zero "Y" plane.
- L203 CARGO LENGTH – CLOSED – SECOND. The dimension measured horizontally from the back of the second seat at the height of the undepressed floor covering to the rearmost point on the undepressed floor covering on the closed tailgate or taildoor for station wagons, trucks and mpv's at the zero "Y" plane.
- L204 CARGO LENGTH AT BELT – FRONT. The minimum dimension measured horizontally from the back of the front seatback at the seatback top to the foremost normal surface of the closed tailgate or inside surface of the cab backpanel at the height of the belt, on the zero "Y" plane.
- L205 CARGO LENGTH AT BELT – SECOND. The minimum dimension measured horizontally from the back of the second seatback at the seatback top to the foremost normal surface of the closed tailgate at the height of the belt, on the zero "Y" plane.
- W201 CARGO WIDTH – WHEELHOUSE. The minimum dimension measured laterally between the trimmed wheelhouses at floor level. For any vehicle not trimmed, measure to the sheet metal.
- W203 REAR OPENING WIDTH AT FLOOR. The minimum dimension measured laterally between the limiting interferences of the rear opening at floor level.
- W204 REAR OPENING WIDTH AT BELT. The minimum dimension measured laterally between the limiting interferences of the rear opening at belt height or top of pick up box.
- W205 REAR OPENING WIDTH ABOVE BELT. The minimum dimension measured laterally between the limiting interferences of the rear opening above the belt height.
- W500 CARGO WIDTH AT FLOOR. The maximum dimension measured laterally between the limiting interferences at the floor level. This dimension shall include ribs and pillars, but will exclude wheelhouses.
- H197 FRONT SEATBACK TO LOAD FLOOR HEIGHT. The dimension measured vertically from the horizontal tangent to the top of the seatback to the undepressed floor covering.
- H201 CARGO HEIGHT. The dimension measured vertically from the top of the undepressed floor covering to the headlining at the rear wheel "X" coordinate on the zero "Y" plane.
- H202 REAR OPENING HEIGHT. The dimension measured vertically from the top of the undepressed floor covering to the upper trimmed opening on the zero "Y" plane with rear door fully open.
- H250 TAILGATE TO GROUND CURB MASS (WT.). The dimension measured vertically from the top of the undepressed floor covering on the lowered tailgate to ground on the zero "Y" plane.
- H505 MAXIMUM CARGO HEIGHT. The maximum vertical dimension rear of the front seat from the cargo floor to roof bow or headlining at the zero "Y" plane.



# MVMA Specifications

## METRIC (U.S. Customary)

### Interior Vehicle And Body Dimensions – Key Sheet Dimensions Definitions

#### V2 STATION WAGON

Measured in inches:

$$\frac{W4 \times H201 \times L204}{1728} = \text{ft}^3$$

Measured in mm:

$$\frac{W4 \times H201 \times L204}{10^9} = \text{m}^3 \text{ (cubic meter)}$$

#### V4 HIDDEN LUGGAGE CAPACITY – REAR OF FRONT SEAT.

The total volumes of individual pieces of one set of standard luggage stowed in any hidden cargo area below the load floor rear of the front seat.

#### V5 TRUCKS AND MPV'S WITH OPEN AREA.

Measured in inches:

$$\frac{L506 \times W505 \times H503}{1728} = \text{ft}^3$$

Measured in mm:

$$\frac{L506 \times W500 \times H503}{10^9} = \text{m}^3 \text{ (cubic meter)}$$

#### V6 TRUCKS AND MPV'S WITH CLOSED AREA.

Measured in inches:

$$\frac{L204 \times W500 \times H505}{1728} = \text{ft}^3$$

Measured in mm:

$$\frac{L204 \times W500 \times H505}{10^9} = \text{m}^3 \text{ (cubic meter)}$$

#### V8 HIDDEN LUGGAGE CAPACITY – REAR OF SECOND SEAT.

The total volume of individual pieces of one set of standard luggage stowed in any hidden cargo area below the load floor rear of the second seat.

#### V10 STATION WAGON CARGO VOLUME INDEX.

Measured in inches:

$$\frac{H201 \times L205 \times \frac{W4 + W201}{2}}{1728} = \text{ft}^3$$

Measured in mm:

$$\frac{H201 \times L205 \times \frac{W4 + W201}{2}}{10^9} = \text{m}^3 \text{ (cubic meter)}$$

#### Hatchback – Cargo Space Dimensions

All hatchback cargo dimensions are to be taken with the front seat in full down and rear position, and the rear seat folded down. The hatchback door is in the closed position. (For electronically adjusted seats, see the manufacturer's specifications for Design "H" Point).

L208 CARGO LENGTH AT FRONT SEATBACK HEIGHT. The minimum horizontal dimension from the "X" plane tangent to the rearmost surface of the driver's seatback to the inside limiting interference of the hatchback door on the vehicle zero "Y" plane.

L209 CARGO LENGTH AT FLOOR – FRONT. The minimum horizontal dimension measured at floor level from the rear of the front seatback to the normal limiting interference of the hatchback door on the vehicle zero "Y" plane.

L210 CARGO LENGTH AT SECOND SEATBACK HEIGHT. The minimum dimension measured from the "X" plane tangent to the rearmost surface of second seatback or the load floor which is stowed at least one half of the H198 dimension height above the rear load floor, to the rearmost inside limiting interference on the zero "X" plane.

L211 CARGO LENGTH AT FLOOR – SECOND SEATBACK. The minimum horizontal dimension measured at floor level from the rear of the second seatback or load floor panel to the normal limiting interference of the hatchback door on the vehicle zero "Y" plane.

H197 FRONT SEATBACK TO LOAD HEIGHT. The dimension measured vertically from the horizontal tangent to the top of the seatback to the undepressed floor covering.

H198 SECOND SEATBACK TO LOAD FLOOR HEIGHT: The dimension measured vertically from the second seatback to the undepressed floor covering.

#### V3 HATCHBACK.

Measured in inches:

$$\frac{\frac{L208 + L209}{2} \times W4 \times H197}{1728} = \text{ft}^3$$

Measured in mm:

$$\frac{\frac{L208 + L209}{2} \times W4 \times H197}{10^9} = \text{m}^3 \text{ (cubic meter)}$$

V4 HIDDEN LUGGAGE CAPACITY – REAR OF FRONT SEAT. The total volumes of individual pieces of one set of standard luggage stowed in any hidden cargo area below the load floor rear of the front seat.

V11 HATCHBACK CARGO VOLUME INDEX. Usable luggage (one (1) stand and luggage set) below floor:

Measured in inches:

$$\frac{\frac{L210 + L211}{2} \times W4 \times H198}{1728} = \text{ft}^3$$

Measured in mm:

$$\frac{\frac{L210 + L211}{2} \times W4 \times H198}{10^9} = \text{m}^3 \text{ (cubic meter)}$$

3

# MVMA Specifications

## METRIC (U.S. Customary)

### Index

Subject	Page No.	Subject	Page No.
Alternator	16	Passenger Capacity	1
Axle Drive, Front, Rear, All Four	2, 9, 10	Passenger Mass Distribution	26
Axle Shafts	10	Pistons	3
Battery	16	Power Brakes	12
Body and Miscellaneous Information	17	Power, Engine	2
Brakes - Parking Service	12, 13	Power Steering	14
Camber	15	Power Teams	2
Camshaft	3	Propeller Shaft	10
Capacities		Pumps - Fuel	6
Cooling System	5	Water	5
Fuel Tank	6	Radiator - Cap, Hoses, Core	5
Lubricants		Ratios - Axle, Transaxle	2, 9, 10
Engine Crankcase	4	Compression	2
Transmission / Transaxle	8, 9	Steering	14
Rear Axle	10	Transmission / Transaxle	2, 8, 9
Carburetor	2, 6	Rear Axle	2, 10
Caster	15	Regulator - Alternator	16
Climate Control System	19	Restraint System	18
Clutch - Pedal Operated	8	Rims	13
Coil, Ignition	16	Rods - Connecting	4
Connecting Rods	4	Scrub Radius	14
Convenience Equipment	20-21	Seats	17
Cooling System	5	Shock Absorbers, Front & Rear	11
Crankshaft	4	Spark Plugs	16
Cylinders and Cylinder Head	3	Speedometer	15
Diesel Information	4	Springs - Front & Rear Suspension	11
Dimension Definitions		Stabilizer (Sway Bar) - Front & Rear	11
Key Sheet - Exterior	28, 31, 32	Starting System	16
Key Sheet - Interior	29, 30, 32, 33, 34	Steering	14
Electrical System	15, 16	Suppression - Ignition, Radio	16
Emission Controls	7	Suspension - Front & Rear	11
Engine - General		Tail Pipe	7
Bore, Stroke, Type	3	Theft Protection	21
Compression Ratio	2	Thermostat, Cooling	5
Displacement	2, 3	Tires	13
Firing Order, Cylinder Numbering	3	Toe-In	15
General Information, Power & Torque	2	Torque Converter	9
Intake System	4	Torque - Engine	2, 8, 9
Power Teams	2	Trailer Towing	21
Exhaust System	7	Transaxle	9
Equipment Availability, Convenience	20	Transmission - Types	2, 8, 9
Fan, Cooling	5	Transmission - Automatic	2, 9
Filters - Engine Oil, Fuel System	4	Transmission - Manual	2, 8
Four Wheel Drive	10	Transmission - Ratios	2, 8, 9
Frame	17	Tread	22
Front Suspension	11	Trunk Cargo Load	1
Front Wheel Drive Unit	10	Trunk Luggage Capacity	23
Fuel Economy, EPA	1	Turning Diameter	14
Fuel Injection	6	Unitized Construction	18
Fuel System	6	Universal Joints, Propeller Shaft	10
Fuel Tank	6	Valve System	4
Glass	18	Vehicle Dimensions	
Headlamps	18	Width	22
Headroom - Body	23, 24	Length	22
Heights	22	Height	22
Horns	15	Ground Clearance	22
Horsepower - Brake	2	Front Compartment	23
Ignition System	16	Rear Compartment	23
Inflation - Tires	13	Luggage Compartment	23
Interior Volumes	23	Station Wagon - Third Seat	24
Instruments	15	Station Wagon - Cargo Space	24
Legroom	23, 24	Hatchback - Cargo Space	24
Lengths	22	Fiducial Marks	25
Leveling, Suspension	11	Voltage Regulator	16
Lifters, Valve	4	Water Pump	5
Linings - Clutch, Brake	8, 12	Weights	26, 27
Lubrication - Engine Transmission / Transaxle	4, 8, 9	Wheel Alignment	15
Luggage Compartment	23	Wheelbase	22
Models	1	Wheels & Tires	13
Motor Starting	16	Wheel Spindle	14
Muffler	7	Widths	22
Origin	1	Windshield	18
		Windshield Wiper and Washer	15

