1

1997 Geo Prizm



GET TO KNOW

Geo

P R I Z M



•
•
•





Prizm

This and other Dealer Order Guide inserts are your first look at Geo models for 1997. Overall improvements, changes and deletions are highlighted. Use these inserts to assist you in ordering your initial shipments. (NOTE: some information is preliminary and is subject to change.)

Positioning Statement

The affordable, high-quality, precision-engineered expression of Geo.



FOCUS: Geo Prizm Sedan

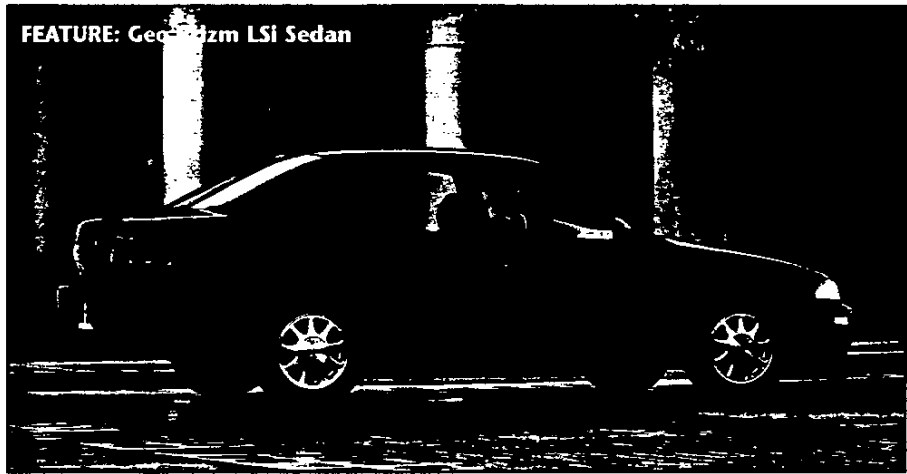

Prizm

FOCUS

Geo Prizm Sedan *(image above, top)*

The Focus vehicle is the model that is chosen for its saleability. It is equipped with the product features that customers want most. Generally, it is the "volume" vehicle that comprises the majority of the build. You'll want to be sure you have several of these models in stock. NOTE: model, PEG and optional equipment may vary in your locality.

The Focus vehicle for 1997 is Prizm Sedan. It features a standard 1.6 Liter engine, driver and front-passenger air bags and a four-wheel independent suspension system. This surprisingly well-equipped sedan, when equipped with PEG 1SB, has the potential to promote high-volume Prizm sales at your dealership.

Ordering Recommendations: Recommended Prizm content, based on national sales volume, is listed below to assist your dealership in ordering.

Sedan with Preferred Equipment Group 1SB content:

- AM/FM Stereo with Four Speakers
- Air Conditioning w/CFC-Free Refrigerant
- Front and Rear Color-Keyed Carpeted Floor Mats
- Full Wheel Covers.

Individual Options:

- 3-Speed Automatic Transmission
- Rear-Window Defogger
- AM/FM Stereo with Cassette Player and Four Speakers
- Intermittent Variable Wipers
- Power Door Locks
- Tachometer.

Popular colors: Desert Sand Metallic, Midnight Emerald Mica and Crimson Cloak Mica-Metallic.

FEATURE

Geo Prizm LSi Sedan *(image above, bottom)*

The Feature vehicle is the "image" model Geo will profile most in its advertising. Generally, it does the best job of capturing attention and creating consumer awareness.

The Feature vehicle for 1997 is Prizm LSi Sedan. Its smooth lines are enhanced by black center pillar trim and unique full wheel covers. This is a striking 5-passenger automobile with impressive roominess at an affordable price. Some of the noteworthy features include:

- Custom Cloth Reclining Front Bucket Seats with Adjustable Head Restraints and Split-Folding 60/40 Rear Seat offer comfort and utility
- Composite Headlamps combine aerodynamic styling, a high level of illumination and easy servicing
- Center Console with Cup Holders, Storage Tray and Covered Storage Box provides convenient storage for beverages, cassettes or CDs
- Black Dual Outside LH Remote and RH Manual Mirrors make adjustments a breeze
- Tilt Steering allows custom placement of the steering column to suit individual preferences
- Dual Covered Visor Mirrors provide a convenient mirror for use by both driver and front passenger
- Driver- and Front-Passenger-Door Storage Bins provide a convenient location for placing loose items
- A Cargo-Area Light provides convenient illumination for easy loading/unloading at night
- Optional Alloy Wheels for enhanced appearance.

Lead Color: Black Mist Metallic.

©1996 GM International



S.P.A.C.E. is an acronym to help organize and explain key features and benefits in five major categories a customer needs and wants. Overall improvements, changes and deletions are highlighted. Please review the supplied information, keeping in mind that this material is provided to you before production startup - and is liable to change.

S.P.A.C.E. (New-for-'97 features appear in color.)



SAFETY AND SECURITY

• **DYNAMIC SIDE-IMPACT STANDARDS** — meet federal requirements. • **DRIVER AND FRONT-PASSENGER AIR BAGS** — help reduce the chance of injury in certain moderate to severe frontal collisions. Always wear safety belts, even with air bags. • **OPTIONAL 4-WHEEL ANTI-LOCK BRAKE SYSTEM (ABS)** — helps reduce wheel lockup and helps driver maintain steering control during severe braking, even on slippery surfaces. • **CHILD SECURITY REAR-DOOR LOCKS** — manually lock, providing security against a child opening rear doors from the inside. • **DUAL-MODE SAFETY BELT RETRACTORS** — make it easier to install child restraint seats in any outboard passenger seating position without the use of extra hardware like "locking clips." • **OPTIONAL REAR INTEGRATED CHILD SAFETY SEAT (LSi ONLY)** — offers added child protection and convenience through seat integration. • **AUTOMATIC DAYTIME RUNNING LAMPS** — help make car more visible to other drivers during day-time hours and in low-light conditions.



PERFORMANCE

• **STANDARD 1.6 LITER ENGINE** — 4-cylinder, 16-valve dual overhead camshaft design with 100 hp at 5600 rpm. • **OPTIONAL 1.8 LITER DOHC ENGINE** — this high-output, 4-cylinder engine delivers 105 hp @ 5200 rpm (optional in Prizm LSi). • **FOUR-WHEEL INDEPENDENT SUSPENSION** — permits each wheel to travel over bumps without disturbing opposite wheel. This suspension is tuned to provide excellent ride and response.



APPEARANCE

• **FOUR NEW EXTERIOR COLORS:** Canyon Red Mica-Metallic, Midnight Emerald Mica, Apricot Ice Mica-Metallic and Lavender Pearl Metallic. • **NEW DOOR-TRIM PANELS** — for an added styling cue to 1997 Prizm. • **BLACK BODY-SIDE MOLDINGS** — Add a European flair to exterior styling. • **BODY-COLOR FRONT AND REAR BUMPERS** — add a contemporary, integrated look to the exterior.



COMFORT AND CONVENIENCE

• **FRONT PASSENGER-SIDE POWER DOOR LOCK SWITCH** — included with optional Convenience Package (LSi only). • **STANDARD POWER STEERING** — for precise control under demanding driving conditions (standard on all Prizm models). • **OPTIONAL AIR CONDITIONING WITH CFC-FREE REFRIGERANT** — quickly cools interior for occupant comfort. • **FRONT SHOULDER SAFETY BELT HEIGHT ADJUSTER** — easily adapts to accommodate passengers of different sizes. • **REAR-CONSOLE HEAT DUCTS** — provide greater heat/air distribution to rear-seat passengers for increased comfort. • **OPTIONAL PRIZM LSi EXPRESSIONS LEATHER PACKAGE** — for added styling. • **REMOTE FUEL-FILLER-DOOR AND TRUNK RELEASES** — allow fuel-filler door and trunk to be opened from inside vehicle. • **DRIVER-DOOR STORAGE BINS** — provide convenient storage compartments (now standard on both Base and LSi models). • **CENTER CONSOLE WITH CUP HOLDERS, STORAGE TRAY AND COVERED STORAGE BOX** — provides convenient storage for beverages, cassettes and CDs and cup holder folds out of the way when not in use (covered storage box on LSi only).



EASY-TO-OWN

• **SCOTCHGARD™ FABRIC PROTECTOR** — on seats and door trim; resists stains and makes cleanup easy. • **STAINLESS-STEEL EXHAUST SYSTEM** — includes all pipes, catalytic converter and muffler to resist corrosion. • **Geo CUSTOMER CARE PACKAGE** — 3-year/36,000-mile, no-deductible limited warranty, 24-hour roadside assistance via toll-free hot line, and courtesy transportation, at participating dealers, if your vehicle ever needs warranty work.

Prizm © 1996 GM Corp. Buckle up, America!

Competitive Models

- Honda Civic
- Toyota Corolla
- Nissan Sentra
- Mazda Protege.

Additional Information on Significant Features

- A Cross-Car Beam underneath the instrument panel contributes to a strong structure and is designed to help reduce passenger compartment intrusion in the event of a side impact. It also provides a strong mounting point for the steering system to help keep the air bag in the proper position and better protect the driver in a frontal collision.
- Prizm features Driver and Front-Passenger Air Bags as standard equipment on all models. Always wear safety belts, even with air bags.
- Child Security Rear-Door Locks are an important safety feature on Prizm Sedan. A switch on the inside rear edge of the doors deactivates the inner door handles. The doors can then be opened only from the outside.
- The extensive use of zinc-rich galvanized steel helps protect Prizm against body rust-through.
- Four new exterior colors have been added: Lavender Pearl Metallic, Midnight Emerald Mica, Apricot Ice Mica-Metallic and Canyon Red Mica-Metallic.
- Twilight Purple, Woodland Green and Bright Red have been deleted.

Feature Availability

	Prizm Sedan	Prizm LSi Sedan
INTERIOR		
Air Bags - Driver and Front-Passenger	S	S
Air Conditioning - with CFC-Free Refrigerant	O	O
Child Safety Seat - Integrated	NA	O ¹
Defogger - Rear-Window	O	O
Door Locks - Power	O	O
- Child Security, Rear	S	S
Floor Mats - Carpeted, Front and Rear	O	O
Heat Ducts - Rear-Console	S	S
Instrumentation - Tachometer	O	O
Scotchgard™ Fabric Protector	S	S
Seats - Prizm Expressions Leather Package	NA	O
Speed Control - Electronic	NA	O
Steering Wheel - Tilt	NA	S
Stereo - AM/FM	O	O
- AM/FM with Cassette Player	O	O
- AM/FM with Cassette and Compact Disc Players	NA	O
Sunroof - Electric	NA	O
Wipers - Intermittent Variable	O	O
EXTERIOR		
Bumpers - Body-Color, Front and Rear	S	S
Corrosion Protection - Lower-Body	S	S
Daytime Running Lamps - Automatic,	S	S
Exhaust System - Stainless-Steel	S	S
Glass - Tinted	S	S
Headlamps - Composite Halogen	S	S
Moldings - Body-side, Black	S	S
Tires - P175/65R-14 All-Season Steel-Belted Radial	S	S
- P185/65R-14 All-Season Steel-Belted Radial	NA	O ²
Wheels - 14" Alloy	NA	O
Wheel Covers - Full	O	NA
- LSi, Full	NA	S
FUNCTIONAL		
Brakes - Power, Front Disc/Rear Drum	S	S
- 4-Wheel Anti-Lock	O	O
Engine - 1.6 Liter DOHC 16-Valve L4 with SFI	S	S
- 1.8 Liter DOHC 16-Valve L4 with SFI	NA	O ³
Steering - Power, Rack-and-Pinion	S	S
Suspension - 4-Wheel Independent	S	S
Transmission - 5-Speed Manual	S	S
- 3-Speed Automatic	O ⁴	O ^{4,5}
- 4-Speed Electronically Controlled Automatic	NA	O ⁶

S - Standard. O - Optional (some options may be available only as part of a Preferred Equipment Group. See your Order Guide for feature availability). NA - Not available. 1 - Not available with leather trim. 2 - Included only with optional 1.8 Liter engine with SFI. 3 - NA with Group 15C. 4 - NA with Group 15A. 5 - Requires 1.6 Liter engine with SFI. 6 - Requires 1.8 Liter engine with SFI.

1997 Geo Prizm PEG/Option Configuration

With Power Steering as standard equipment for 1997, Geo Prizm Preferred Equipment Groups were enhanced to reflect popular equipment ordering trends. Listed below are the new PEGs for the 1997 Model Year as compared with last year's offering:

'96 Geo Prizm Sedan

Preferred Equipment Group 1

Standard Equipment - Base Model

Preferred Equipment Group 2

AM/FM Stereo
Power Steering
Floor Mats

'97 Geo Prizm Sedan

Preferred Equipment Group 1

Standard Equipment - Base Model

Preferred Equipment Group 2

AM/FM Stereo
Air Conditioning (New)
Floor Mats
Wheels, Full Cover (New)

'96 Geo Prizm LSi Sedan

Preferred Equipment Group 1

Standard Equipment - LSi Model

Preferred Equipment Group 2

AM/FM Stereo
Dual Outside Electric Mirrors
Floor Mats
Power Steering

Preferred Equipment Group 3

Air Conditioning
Intermittent Variable Wipers

'97 Geo Prizm LSi Sedan

Preferred Equipment Group 1

Standard Equipment - LSi Model

Preferred Equipment Group 2

AM/FM/Cassette Stereo (New)
Dual Outside Electric Mirrors
Floor Mats
Air Conditioning (New)

Preferred Equipment Group 3

Convenience Package (New)
Intermittent Variable Wipers

MANUFACTURERS MOTOR VEHICLE SPECIFICATIONS

METRIC (U.S. CUSTOMARY)

1997

Manufacturer	NEW UNITED MOTOR MFG., INC. (NUMMI)	Vehicle Line	Geo PRIZM	
Mailing Address	GENERAL MOTORS CORPORATION CHEVROLET CENTRAL OFFICE 30007 VAN DYKE WARREN, MI 48090-9065	Issued	Revised	

Direct questions concerning these specifications to the manufacturer listed above.

The information contained herein is prepared, distributed by, and is solely the responsibility of the vehicle manufacturing company to whose products it relates. This specification form was developed by the vehicle manufacturing companies under the auspices of the American Automobile Manufacturers Association.

The General Specifications herein are those in effect at date of compilation and are subject to change without notice or incurring obligation by the manufacturer.

AAMA

American Automobile Manufacturers Association

Blank Forms Provided by Technical Affairs Division

MVMA Specifications

Vehicle Line Geo PRIZM
 Model Year 1998 Issued _____ Revised (#) _____
 7

METRIC (U.S. Customary)

Vehicle Origin

Design & development (company)	Toyota Motor Corporation
Where built (country)	U.S.A.
Authorized U.S. sales marketing representative	Chevrolet / Geo

Vehicle Models

Model Description & Drive (FWD / RWD / AWD / 4WD)*	Introduction Date	Make, Vehicle Models, Series, Body Type (Mfr's Model Code)	No. of Designated Seating Positions (Front / Rear)	Max. Trunk/Cargo Load-Kilograms (Pounds)	EPA Fuel Economy (City/Hwy)
Geo PRIZM 4-Door Notchback Sedan (FWD)		1SK19	5 (2/3)	45 (100)	M/T TBD A/T TBD
Geo PRIZM LSi 4-Door Notchback Sedan (FWD)		1SK19	5 (2/3)	45 (100)	M/T TBD A/T TBD

* FWD - Front Wheel Drive RWD - Rear Wheel Drive AWD - All Wheel Drive 4WD - Four Wheel Drive

MVMA Specifications

Model Year 1998 Issued _____ Revised (●) _____
 7

METRIC (U.S. Customary)

Engine Description
 Engine Code

1.6 LITER L4 (97 CID) MULTI-PORT FUEL INJECTION RPO L01

Engine - General

Type & description (inline, V, angle, flat, location, front, mid, rear, transverse, longitudinal, sohc, dohc, ohv, hemi, wedge, pre-chamber, etc.)	Inline, Front, Transverse, DOHC Pent Roof	
Manufacturer	Toyota Motor Corporation	
No. of cylinders	4	
Bore	81.0 mm (3.2 in.)	
Stroke	77.0 mm (3.0 in.)	
Bore Spacing (C / L to C / L)	87.5 mm (3.4 in.)	
Cylinder block material & mass kg. (lbs.) (machined)	Cast Iron, 31.3 (69.0)	
Cylinder block deck height	191.0 mm (7.5 in.)	
Cylinder block length	391.5 mm (15.4 in.)	
Deck clearance (minimum) (above or below block)	0.00 mm	
Cylinder head material & mass kg. (lbs.)	Aluminum Alloy, 11.0 (24.3)	
Cylinder head volume cm ³ (inches ³)	33.7 (2.1)	
Cylinder liner material	Not Applicable	
Head gasket thickness (compressed)	1.20 mm (.05 in.)	
Minimum combustion chamber total volume cm ³ (inches ³)	51.8 (3.2)	
Cyl. no. system (front to rear)*	L. Bank	1-2-3-4
	R. Bank	
Firing order	1-3-4-2	
Intake manifold material & mass kg. (lbs.)**	Aluminum Alloy, 4.2 (17.0)	
Exhaust manifold material & mass kg. (lbs.)**	Cast Iron, 4.0 (8.8)	
Knock sensor (number & location)	No	
Fuel required unleaded, diesel, etc.	Unleaded	
Fuel antiknock index (R + M) + 2	87	
Engine Mounts	Quantity	4
	Material and type (elastomeric, hydroelastic, hydraulic damper, etc.)	RH: Hydroelastic Other: Elastomeric
	Added isolation (sub-frame, crossmember, etc.)	Fr: CTR Member, RR: Sub-Frame, RH: RH Side Member, LH: LH Side Member
Total dressed engine mass (wt) dry***	M/T: 126 kg (277.8 lbs)	A/T: 118 kg (260.1 lbs)

Engine - Pistons

Material & mass, g (weight, oz.) - piston only	Aluminum Alloy, 278 (9.8)
--	---------------------------

Engine - Camshaft

Location	Over Cylinder Head	
Material & mass kg (weight, lbs.)	Gray Cast Iron, Intake = 1.9 (4.19) Exhaust = 2.1 (4.62)	
Drive type	Chain / belt	Belt
	Width / pitch	8.0 / 21.1 mm (31 / 831 in.)

- * Rear of engine - drive takeoff. View from drive takeoff end to determine left & right side of engine
- ** Finished state
- *** Dressed engine mass (weight) includes the following: All those items necessary to make the engine a complete ready-to-run unit

MVMA Specifications

Vehicle Line Geo PRLZM
 Model Year 1996 Issued _____ Revised (®) _____

7

METRIC (U.S. Customary)

Engine Description
 Engine Code

1.8 LITER L4 (108 CID) MULTI-PORT FUEL INJECTION RPO LV6

Engine - General

Type & description (inline, V angle, flat, location, front, mid, rear, transverse, longitudinal, sohc, dohc, ohv, hemi, wedge, pre-chamber, etc.)	Inline, Front, Transverse, DOHC Pent Roof	
Manufacturer	Toyota Motor Corporation	
No. of cylinders	4	
Bore	81.0 mm (3.2 in.)	
Stroke	85.5 mm (3.4 in.)	
Bore Spacing (C/L to C/L)	87.5 mm (3.4 in.)	
Cylinder block material & mass kg (lbs.) (machined)	Cast Iron, 33.0 (72.8)	
Cylinder block deck height	206.4 mm (8.1 in.)	
Cylinder block length	391.5 mm (15.4 in.)	
Deck clearance (minimum) (above or below block)	0.00 mm	
Cylinder head material & mass kg (lbs.)	Aluminum Alloy, 11.0 (24.3)	
Cylinder head volume cm ³ (inches ³)	33.7 (2.1)	
Cylinder liner material	Not Applicable	
Head gasket thickness (compressed)	.56 mm (0.22 in.)	
Minimum combustion chamber total volume cm ³ (inches ³)	46.6 (2.8)	
Cyl. no system (front to rear)*	L Bank	1-2-3-4
	R Bank	
Firing order	1-3-4-2	
Intake manifold material & mass kg (lbs.)**	Aluminum Alloy, 4.2 (17.0)	
Exhaust manifold material & mass kg (lbs.)**	Cast Iron, 4.0 (8.8)	
Knock sensor (number & location)	Yes	
Fuel required unleaded, diesel, etc.	Unleaded	
Fuel antiknock index (R + M) - 2	87	
Engine Mounts	Quantity	4
	Material and type (elastomeric, hydroelastic, hydraulic damper, etc.)	RH: Hydroelastic Other: Elastomeric
	Added isolation (sub-frame, crossmember, etc.)	Fr: CTR Member, RR: Sub-Frame, RH: RH Side Member, LH: LH Side Member
Total dressed engine mass (wt) dry***	M/T: 130 kg (286.6 lbs)	A/T: 122 kg (269.0 lbs)

Engine - Pistons

Material & mass, g (weight, oz) - piston only	Aluminum Alloy, 268 (9.5)
---	---------------------------

Engine - Camshaft

Location	Over Cylinder Head	
Material & mass (g weight, lbs)	Gray Cast Iron, Intake = 1.9 (419) Exhaust = 2.1 (462)	
Drive type	Chain belt	Belt
	Width pitch	8.0 / 21.1 mm (31 / 831 in)

- * Rear of engine - drive takeoff. View from drive takeoff end to determine left & right side of engine
- ** Finished state
- *** Dressed engine mass (weight) includes the following. All these items necessary to make the engine a complete ready-to-run unit.

MVMA Specifications

Vehicle Line Geo PRIZM
 Model Year 1998 Issued _____ Revised (®) _____

METRIC (U.S. Customary)

Engine Description
 Engine Code

1.6 LITER L4 (97 CID) MULTI-PORT FUEL INJECTION RPO L01

Engine - Valve System

Hydraulic lifters (std., opt., n/a)		Not Applicable
Valves	Number intake / exhaust	8/8
	Head O.D. intake / exhaust	31/24.5 mm (1.2/964 in.)

Engine - Connecting Rods

Material & mass kg., (weight, lbs.)*	Forged Steel, 0.44 (0.97)
Length (axes C/L to C/L)	122 mm (4.8 in.)

Engine - Crankshaft

Material & mass kg., (weight, lbs.)*	Forged Steel, 12.2 (26.9)	
End thrust taken by bearing (no)	# 3	
Length & number of main bearings	489 mm (19.3 in.), 5	
Seal (material one, two piece design, etc.)	Front	Synthetic Rubber, One Piece
	Rear	Synthetic Rubber, One Piece

Engine - Lubrication System

Normal oil pressure kPa (psi) at engine rpm	294 (42.6) / 6000
Type oil intake (floating, stationary)	Stationary
Oil filter system (full flow, part, other)	Full Flow
Capacity of c/case, less filter-refill-L (qt.)	3.1 (3.3)

Engine - Diesel Information

Not Applicable

Diesel engine manufacturer		
Glow plug, current drain at 0°F		
Injector nozzle	Type	
	Opening pressure kPa (psi)	
Pre-chamber design		
Fuel injection pump	Manufacturer	
	Type	
Fuel injection pump drive (belt, chain, gear)		
Supplementary vacuum source (type)		
Fuel heater (yes/no)		
Water separator, description (std., opt.)		
Turbo manufacturer		
Oil cooler-type (oil to engine coolant, oil to ambient air)		
Oil filter		

Engine - Intake System

Not Applicable

Turbo charger - manufacturer		
Super charger - manufacturer		
Intercooler		

* Finished State

MVMA Specifications

VEHICLE LINE Geo Prizm
 Model Year 1998 Issued _____ Revised (●) _____

7

METRIC (U.S. Customary)

Engine Description
 Engine Code

1.8 LITER L4 (108 CID) MULTI-PORT FUEL INJECTION RPO LV6

Engine - Valve System

Hydraulic lifters (std., opt., n.s.)		Not Applicable
Valves	Number intake / exhaust	8/8
	Head O D intake / exhaust	31/24 5 mm (1 2/964 in.)

Engine - Connecting Rods

Material & mass kg. (weight, lbs)*	Forged Steel, 0.44 (0.97)
Length (axes CL to CL)	132.5 MM (5.2 in.)

Engine - Crankshaft

Material & mass kg. (weight, lbs)*	Forged Steel, 14.3 (31.5)	
End thrust taken by bearing (no.)	# 3	
Length & number of main bearings	489 mm (19.3 in.), 5	
Seal (material, one, two piece design, etc.)	Front	Synthetic Rubber, One Piece
	Rear	Synthetic Rubber, One Piece

Engine - Lubrication System

Normal oil pressure kPa (psi) at engine rpm	294 (42.6) / 6000
Type of intake (floating, stationary)	Stationary
Oil filter system (full flow, part, other)	Full Flow
Capacity of oilcase, less filter-refill-L (qt.)	3.5 (3.7)

Engine - Diesel Information

Not Applicable

Diesel engine manufacturer		
Glow plug, current drain at 0°F		
Injector nozzle	Type	
	Opening pressure kPa (psi)	
Pre-chamber design		
Fuel injection pump	Manufacturer	
	Type	
Fuel injection pump drive (belt, chain, gear)		
Supplementary vacuum source (type)		
Fuel heater (yes/no)		
Water separator, description (std., opt.)		
Turbo manufacturer		
Oil cooler-type (oil to engine coolant, oil to ambient air)		
Oil filter		

Engine - Intake System

Not Applicable

Turbo charger - manufacturer	
Super charger - manufacturer	
Intercooler	

* Finished State

MVMA Specifications

Vehicle Line Geo Prizm
 Model Year 1999 Issued _____ Revised (®) _____

7

METRIC (U.S. Customary)

Engine Description
 Engine Code

1.6 LITER L4 (97 CID) MULTI-PORT FUEL INJECTION RPO L01

Engine - Cooling System

Coolant recovery system (std., opt., n/a)		Standard
Coolant fill location (rad., bottle)		Radiator
Radiator cap relief valve pressure kPa (psi)		90 (13.1)
Circulation thermostat	Type (choke, bypass)	Bypass
	Starts to open at °C (°F)	82 (179.6)
Water pump	Type (centrifugal, other)	Centrifugal
	GMP 1000 pump rpm	16 L/min.
	Number of pumps	1
	Drive (V-belt, other)	V-Belt
	Bearing type	Sealed
	Impeller material	Stainless Steel
	Housing material	Aluminum Alloy
By-pass recirculation type (inter., ext.)		External
Cooling System capacity	With heater - L (qt.)	6.0 (6.3) MT; 5.9 (6.2), A/T
	With air conditioner - L (qt.)	6.0 (6.3) MT; 5.9 (6.2), A/T
	Opt. equipment specify - L (qt.)	Not Applicable
Water jackets full length of cyl. (yes, no)		Yes
Water all around cylinder (yes, no)		No
Water jackets open at head face (yes, no)		No
Radiator core	Std. A/C, HD	Standard
	Type (cross-flow, etc.)	Vertical Flow
	Construction (fin & tube mechanical, brazes, etc.)	Corrugated Fin
	Material, mass kg (wgt., lbs.)	Aluminum or Copper-Brass, 3.4 (7.5), M/T; 3.1 (6.8) or 5.3 (11.7), A/T
	Width	701 mm (27.6 in.) or 699 mm (27.5 in.)
	Height	348 mm (13.7 in.) or 350 mm (13.8 in.)
	Thickness	27 mm (1.1 in.)
Radiator end tank material		Plastics
Fan	Std., elec., opt.	Electric
	Number of blades & type (flex, solid, material)	5, Plastics
	Number & location (front, rear of radiator)	1, Rear of Radiator
	Diameter & projected width	300/100 mm (11.8/3.9 in.)
	Ratio (fan to crankshaft rev.)	Not Available
	Fan cutout type	Temperature Controlled
	Drive type (direct, remote)	Electric Motor
	RPM at idle (elec.)	2180
	Motor rating (wattage/elec.)	80
	Motor switch (type & location/elec.)	Thermo Switch Thermoster at Water Inlet
	Switch point (temp./pressure/elec.)	90 Degree C
Fan shroud (material)		Plastics

MVMA Specifications

Vehicle Line Geo PRIZM
 Model Year 1999 Issued _____ Revised (®) _____

7

METRIC (U.S. Customary)

Engine Description
 Engine Code

1.8 LITER L4 (108 CID) MULTI-PORT FUEL INJECTION RPO LV6

Engine - Cooling System

Coolant recovery system (std., opt., n.a.)		Standard
Coolant fill location (rad., bottle)		Radiator
Radiator cap relief valve pressure kPa (psi)		90 (13.1)
Circulation thermostat	Type (choke, bypass)	Bypass
	Starts to open at °C (°F)	82 (179.6)
Water pump	Type (centrifugal, other)	Centrifugal
	GMP 1000 pump rpm	16 L/min.
	Number of pumps	1
	Drive (V-belt, other)	V-Belt
	Bearing type	Sealed
	Impeller material	Stainless Steel
Housing material		Aluminum Alloy
By-pass recirculation type (inter., ext.)		External
Cooling System capacity	With heater - L (qt.)	6.2 (6.6) MT; 6.1 (6.4) OR 6.2 (6.6), A/T
	With air conditioner - L (qt.)	6.2 (6.6) MT; 6.1 (6.4) OR 6.2 (6.6), A/T
	Opt. equipment specify - L (qt.)	Not Applicable
Water jackets full length of cyl. (yes, no)		Yes
Water all around cylinder (yes, no)		No
Water jackets open at head face (yes, no)		No
Radiator core	Std., A/C, HD	Standard
	Type (cross-flow, etc.)	Vertical Flow
	Construction (fin & tube mechanical, braze, etc.)	Corrugated Fin
	Material, mass kg (wgt., lbs.)	Aluminum or Copper-Brass, 3.4 (7.5), M/T: 3.1 (6.8) or 5.3 (11.7), A/T
	Width	701 mm (27.6 in.) or 699 mm (27.5 in.)
	Height	348 mm (13.7 in.) or 350 mm (13.8 in.)
	Thickness	27 mm (1.1 in.)
Fins per inch		Pitch = 3.0 mm
Radiator end tank material		Plastics
Fan	Std., elec., opt.	Electric
	Number of blades & type (flex, solid, material)	5, Plastics
	Number & location (front, rear of radiator)	1, Rear of Radiator
	Diameter & projected width	300/100 mm (11.8/3.9 in.)
	Ratio (fan to crankshaft rev.)	Not Available
	Fan cutout type	Temperature Controlled
	Drive type (direct, remote)	Electric Motor
	RPM at idle (elec.)	2180
	Motor rating (wattage/elec.)	80
	Motor switch (type & location/elec.)	Thermo Switch Thermoster at Water Inlet
	Switch point (temp., pressure/elec.)	90 Degree C
Fan shroud (material)		Plastics

MVMA Specifications

Vehicle Line Geo PRIZM
 Model Year 1998 Issued _____ Revised (9) _____

7

METRIC (U.S. Customary)

Engine Description
 Engine Code

1.6 LITER L4 (97 CID) MULTI-PORT FUEL INJECTION RPO L01

Engine - Fuel System (See Supplemental page for details of Fuel Injection, Supercharger, Turbocharger, etc. if used.)

Induction type carburetor, fuel injection system, etc.		Fuel Injection
Manufacturer		Nippondenso
Carburetor no. of barrels		-
Idle A/F max.		Not Adjustable
Fuel injection	Point of injection (no.)	4
	Constant pulse flow	Pulse Flow
	Control (electronic, mech.)	Electronic
	System pressure kPa (psi)	284 (41.2)
Idle speed-rpm (spec neutral or drive and propane if used)	Manual	700
	Automatic	700
Intake manifold heat control (exhaust or water thermostatic or fixed)		-
Air cleaner type		Oiled Paper Type, 1 Element
Fuel filter (type/location)		Paper Element 1 Piece Type at Left Side of Engine Compartment
Fuel pump	Type (elec. or mech.)	Electric
	Location (eng., tank)	In Fuel Tank
	Pressure range kPa (psi)	284 (41.2)
	Flow rate at regulated pressure L (gal)/hr @ kPa (psi)	Min. 80 (21) / hr @ 284 (41.2)

Fuel Tank

Capacity refill L (gallons)		50 (13.2)
Location (describe)		Underside of Rear Seat Floor
Attachment		Banded & Bolts
Material & Mass kg. (weight lbs.)		Steel
Filter pipe	Location & material	Left Quarter Panel Steel
	Connection to tank	Rubber Hose
Fuel line (material)		Steel
Fuel hose (material)		Rubber
Return line (material)		Steel
Vapor line (material)		Steel
Extended range tank	Opt. n a	Not Applicable
	Capacity L (gallons)	-
	Location & material	-
	Attachment	-
Auxiliary tank	Opt. n a	Not Applicable
	Capacity L (gallons)	-
	Location & material	-
	Attachment	-
	Selector switch or valve	-
Separate fill		-

MVMA Specifications

Vehicle Line 1996 F150 F150L
 Model Year 1996 Issued _____ Revised (®) _____

7

METRIC (U.S. Customary)

Engine Description
 Engine Code

1.6 LITER L4 (97 CID) MULTI-PORT FUEL INJECTION RPO L01

Engine - Fuel System (See Supplemental page for details of Fuel Injection, Supercharger, Turbocharger, etc. if used)

Induction type carburetor, fuel injection system, etc		Fuel Injection
Manufacturer		Nippondenso
Carburetor no. of barrels		-
Idle A/F max.		Not Adjustable
Fuel injection	Point of injection (no.)	4
	Constant, pulse, flow	Pulse, Flow
	Control (electronic, mech.)	Electronic
	System pressure kPa (psi)	284 (41.2)
Idle speed-rpm (spec. neutral or drive and propane if used)	Manual	700
	Automatic	700
Intake manifold heat control (exhaust or water thermostatic or fixed)		-
Air cleaner type		Oiled Paper Type, 1 Element
Fuel filter (type/location)		Paper Element 1 Piece Type at Left Side of Engine Compartment
Fuel pump	Type (elec. or mech.)	Electric
	Location (eng. tank)	In Fuel Tank
	Pressure range kPa (psi)	284 (41.2)
	Flow rate at regulated pressure L (gal)/hr @ kPa (psi)	Min. 80 (21) / hr @ 284 (41.2)

Fuel Tank

Capacity refill L (gallons)		50 (13.2)
Location (describe)		Underside of Rear Seat Floor
Attachment		Banded & Bolts
Material & Mass kg (weight lbs)		Steel
Filler pipe	Location & material	Left Quarter Panel Steel
	Connection to tank	Rubber Hose
Fuel line (material)		Steel
Fuel hose (material)		Rubber
Return line (material)		Steel
Vapor line (material)		Steel
Extended range tank	Opt. n.a	Not Applicable
	Capacity L (gallons)	"
	Location & material	"
	Attachment	"
Auxiliary tank	Opt. n.a	Not Applicable
	Capacity L (gallons)	"
	Location & material	"
	Attachment	"
	Selector switch or valve	"
Separate fill		"

MVMA Specifications

Vehicle Line Geo PRIZM
 Model Year 1996 Issued _____ Revised (®) _____
 7

METRIC (U.S. Customary)

Engine Description
 Engine Code

1.8 LITER L4 (108 CID) MULTI-PORT FUEL INJECTION RPO LV6

Engine - Fuel System (See Supplemental page for details of Fuel Injection, Supercharger, Turbocharger, etc. if used)

Induction type carburetor, fuel injection system, etc.		Fuel Injection
Manufacturer		Nippondenso
Carburetor no. of barrels		--
Idle A/F max.		Not Adjustable
Fuel injection	Point of injection (no.)	4
	Constant, pulse, flow	Pulse, Flow
	Control (electronic, mech.)	Electronic
	System pressure kPa (psi)	284 (41.2)
Idle speed-rpm (spec. neutral or drive and propane if used)	Manual	700
	Automatic	700
Intake manifold heat control (exhaust or water thermostatic or fixed)		--
Air cleaner type		Oiled Paper Type, 1 Element
Fuel filter (type/location)		Paper Element 1 Piece Type at Left Side of Engine Compartment
Fuel pump	Type (elec. or mech.)	Electric
	Location (eng., tank)	In Fuel Tank
	Pressure range kPa (psi)	284 (41.2)
	Flow rate at regulated pressure L (gal)/hr @ kPa (psi)	Min. 80 (21) / hr @ 284 (41.2)

Fuel Tank

Capacity refill L (gallons)		50 (13.2)
Location (describe)		Underside of Rear Seat Floor
Attachment		Banded & Bolts
Material & Mass kg. (weight lbs.)		Steel
Filler pipe	Location & material	Left Quarter Panel Steel
	Connection to tank	Rubber Hose
Fuel line (material)		Steel
Fuel hose (material)		Rubber
Return line (material)		Steel
Vapor line (material)		Steel
Extended range tank	Opt., n.a.	Not Applicable
	Capacity L (gallons)	"
	Location & material	"
	Attachment	"
Auxiliary tank	Opt., n.a.	Not Applicable
	Capacity L (gallons)	"
	Location & material	"
	Attachment	"
	Selector switch or valve	"
Separate fill		"

MVMA Specifications

Vehicle Line Geo PRIZM
 Model Year 1998 Issued _____ Revised (®) _____

7

METRIC (U.S. Customary)

Engine Description
 Engine Code

1.6 LITER L4 (97 CID) MULTI-PORT FUEL INJECTION RPO L01

Vehicle Emission Control

Type (air injection, engine modifications, other)		SFI + Oxygen Sensor + TWC + EGR		
Exhaust Emission Control	Air injection	Pump or pulse	Not Applicable	
		Driven by	-	
		Air distribution (head, manifold, etc.)	-	
		Point of entry	-	
	Exhaust Gas Recirculation	Type (controlled flow, open orifice, other)	Controlled Flow	
		Exhaust source	Cylinder Head Port	
		Point of exhaust injection (spacer, carburetor, manifold, other)	Intake Manifold	
	Catalytic Converter	Type	TWC	
		Number of	1	
		Location(s)	Forward Under Floor Area	
Volume L (in ³)		1.3 (79.6), Fed.; 1.7 (91.8), Calif.		
Substrate type		Monolith		
Noble metal type		Platinum (Pt), Rhodium (Rh)		
Noble metal concentration (g/cm ³)	Pt = 1.76, Rh = 0.35, Fed. Pt = 2.08, Rh = 0.38 or 0.35, Calif.			
Crankcase Emission Control	Type (ventilates to atmosphere, induction system, other)		Induction System, Closed Type	
	Energy source (manifold vacuum, carburetor, other)		Manifold Vacuum	
	Discharges to (intake manifold, other)		Intake Manifold	
	Air inlet (breather cap, other)		Throttle Body	
Evaporative Emission Control	Vapor vented to (crankcase, canister, other)	Fuel Tank	Canister	
		Carburetor	-	
	Vapor storage provision		Charcoal Coal	
Electronic system	Closed loop (yes/no)		Yes	
	Open loop (yes/no)		No	

Engine - Exhaust System

Type (single, single with cross-over, dual, other)		Single
Muffler no. & type (reverse flow, straight thru, separate resonator), Muffler volume (liters), Material & Mass kg (weight lbs)		1, Straight Thru, 2, Reverse Flow - Stainless Steel 2.0 (4.4), 5.0 (11.0)
Resonator no., type, & volume (liters)		-
Exhaust Pipe	Branch o.d., wall thickness	-
	Main o.d., wall thickness	48.6/2.0 mm (1.9/0.079 in.), 48.6/1.5 mm (1.9/0.059 in.) Fed 48.6/1.5 mm (1.9/0.059 in.), Calif.
	Material & Mass kg (weight lbs)	Stainless Steel, 3.5 (7.7)
Intermediate Pipe	o.d. & wall thickness	48.6/1.2 mm (1.9/0.047 in.); 42.7/1.2 mm (1.7/0.047 in.)
	Material & Mass kg (weight lbs)	Stainless Steel, 4.9 (10.8)
Tail Pipe	o.d. & wall thickness	42.7/1.2 mm (1.7/0.047 in.), 48.6/1.0 mm (1.9/0.039 in.)
	Material & Mass kg (weight lbs)	Stainless Steel, 6.5 (14.3)

MVMA Specifications

Vehicle Line Geo PRIZM
 Model Year 1998 Issued _____ Revised (9) _____

7

METRIC (U.S. Customary)

Engine Description
 Engine Code

1.8 LITER L4 (108 CID) MULTI-PORT FUEL INJECTION RPO LV6

Vehicle Emission Control

Type (air injection, engine modifications, other)		SFI + Oxygen Sensor + TWC + EGR		
Exhaust Emission Control	Air injection	Pump or pulse	Not Applicable	
		Driven by	-	
		Air distribution (head, manifold, etc.)	-	
		Point of entry	-	
	Exhaust Gas Recirculation	Type (controlled flow, open orifice, other)	Controlled Flow	
		Exhaust source	Cylinder Head Port	
		Point of exhaust injection (spacer, carburetor, manifold, other)	Intake Manifold	
	Catalytic Converter	Type	TWC	
		Number of	1	
		Location(s)	Forward Under Floor Area, Fed & Calif.; Exhaust Manifold, Calif.	
Volume L (in ³)		1.3 (79.6), Fed.; 1.5 (91.8), Calif.-Exhaust Manifold + 0.500 (Under Floor)		
Substrate type		Monolith, Fed.; Metal Foil + Monolith, Calif.		
Noble metal type		Platinum (Pt), Rhodium (Rh)		
Crankcase Emission Control	Type (ventilates to atmosphere, induction system, other)	Induction System, Closed Type		
		Manifold Vacuum		
	Energy source (manifold vacuum, carburetor, other)	Intake Manifold		
		Throttle Body		
Evaporative Emission Control	Vapor vented to (crankcase, canister, other)	Fuel Tank	Canister	
		Carburetor	-	
	Vapor storage provision		Charcoal Coal	
Electronic system	Closed loop (yes/no)	Yes		
	Open loop (yes/no)	No		

Engine - Exhaust System

Type (single, single with cross-over, dual, other)		Single
Muffler no. & type (reverse flow, straight thru, separate resonator), Muffler volume (liters), Material & Mass kg (weight lbs)		1, Straight Thru; 2, Reverse Flow - Stainless Steel 2.0 (4.4), 5.0 (11.0)
Resonator no., type, & volume (liters)		-
Exhaust pipe	Branch o.d., wall thickness	-
	Main o.d., wall thickness	48.6/2.0 mm (1.9/0.079 in.), 48.6/1.5 mm (1.9/0.059 in.), Fed. 48.6/1.5 mm (1.9/0.059 in.), Calif.
	Material & Mass kg (weight lbs)	Stainless Steel, 3.5 (7.7)
Intermediate pipe	o.d. & wall thickness	48.6/1.2 mm (1.9/0.047 in.), 42.7/1.2 mm (1.7/0.047 in.)
	Material & Mass kg (weight lbs)	Stainless Steel, 4.9 (10.8)
Tail pipe	o.d. & wall thickness	42.7/1.2 mm (1.7/0.047 in.), 48.6/1.0 mm (1.9/0.039 in.)
	Material & Mass kg (weight lbs)	Stainless Steel, 6.5 (14.3)

MVMA Specifications

Vehicle Line Geo PRIZM
 Model Year 1997 7 Issued _____ Revised (#) _____

METRIC (U.S. Customary)

Engine Description
 Engine Code

1.6 LITER L4 (97 CID) MULTI-PORT FUEL INJECTION RPO L01

Transmissions/Transaxle (Std., Opt., N.A.)

Manual 4-speed (manufacturer/country)	Not Available
Manual 5-speed (manufacturer/country)	Standard, TMC/Japan
Manual 6-speed (manufacturer/country)	Not Available
Automatic (manufacturer/country)	Standard, TMC/ Japan
Automatic overdrive (manufacturer/country)	Not Applicable

Manual Transmission/Transaxle

Number of forward speeds		5
Gear ratios	1st	3.545
	2nd	1.904
	3rd	1.310
	4th	0.969
	5th	0.815
	6th	-
Reverse		3.250
Synchronous meshing (specify gears)		All Forward Speeds
Shift lever location		Floor
Trans. case material & mass kg. (lbs.)*		Aluminum Die Cast, 37.5 (82.7) - Wet
Lubricant	Capacity L (pt.)	2.6 (5.5)
	Type recommended	APT GL-3, GL-4, GL-5

Clutch (Manual Transmission)

Clutch manufacturer		AISIN
Clutch type (dry, wet, single, multiple disc)		Dry, Single, Diaphragm
Linkage (hydraulic, cable, rod, lever, other)		Hydraulic
Max. pedal effort (nom. spring load) N (lbs.)	Depressed	110 (24.7)
	Released	110 (24.7)
Assist (spring, power/percent, nominal)		0
Type pressure plate springs		Diaphragm Spring
Total spring load (nominal) N (lbs.)		4200 (944.2)
Clutch facing	Facing mfg. & material coding	NISSINBO
	Facing material & construction	Semi-Mold
	Rivets per facing	16
	Outside x inside dia. (nominal)	212 x 140 mm (8.3 x 5.51 in.)
	Total eff. area cm ² (in. ²)	199 (30.8)
	Thickness (pressure plate side/fly wheel side)	3.5 mm (.138 in.)
	Rivet depth (pressure plate side/fly wheel side)	1.6 / 1.6 mm (.063 / .063 in.)
Engagement cushion method		Wave Spring Segments
Release bearing type & method lub		Self-Centering Ball Bearing with Permanent Lubrication
Torsional damping method, springs hysteresis		Single-Stage Torsional Rubber with Friction Washer

* Includes shift linkage, lubricant, and clutch housing, if other specify

MVMA Specifications

Vehicle Line Geo PRIZM
 Model Year 1997 Issued _____ Revised (#) _____

7

METRIC (U.S. Customary)

Engine Description
 Engine Code

1.8 LITER L4 (108 CID) MULTI-PORT FUEL INJECTION RPO LV6

Transmissions/Transaxle (Std., Opt., N.A.)

Manual 4-speed (manufacturer/country)	Not Available
Manual 5-speed (manufacturer/country)	Standard, TMC/Japan
Manual 6-speed (manufacturer/country)	Not Available
Automatic (manufacturer/country)	Standard, AISIN AW/ Japan
Automatic overdrive (manufacturer/country)	Not Applicable

Manual Transmission/Transaxle

Number of forward speeds		5
Gear ratios	1st	3.166
	2nd	1.904
	3rd	1.310
	4th	0.969
	5th	0.815
	6th	-
	Reverse	3.250
Synchronous meshing (specify gears)		All Forward Speeds
Shift lever location		Floor
Trans. case material & mass kg (lbs.)*		Aluminum Die Cast, 37.5 (82.7) - Wet
Lubricant	Capacity L (pt.)	2.6 (5.5)
	Type recommended	APT GL-3, GL-4, GL-5

Clutch (Manual Transmission)

Clutch manufacturer		AISIN
Clutch type (dry, wet, single, multiple disc)		Dry, Single, Diaphragm
Linkage (hydraulic, cable, rod, lever, other)		Hydraulic
Max. pedal effort (nom. spring load) N (lbs.)	Depressed	120 (27.0)
	Released	120 (27.0)
Assist (spring, power/percent, nominal)		0 w/ABS, 30 w/o ABS
Type pressure plate springs		Diaphragm Spring
Total spring load (nominal) N (lbs.)		4400 (989.2)
Clutch facing	Facing mfg. & material coding	AISIN CHEMICAL
	Facing material & construction	Semi-Mold
	Rivets per facing	16
	Outside x inside dia. (nominal)	212 x 140 mm (8.3 x 5.51 in.)
	Total eff. area cm ² (in. ²)	199 (30.8)
	Thickness (pressure plate side/fly wheel side)	3.5 mm (.138 in.)
	Rivet depth (pressure plate side/fly wheel side)	1.6 / 1.6 mm (.063 / .063 in.)
Engagement cushion method		Wave Spring Segments
Release bearing type & method lub		Self-Centering Ball Bearing with Permanent Lubrication
Torsional damping method, springs, hysteresis		Single-Stage Torsional Rubber with Friction Washer

* Includes shift linkage, lubricant, and clutch housing. If other specify

MVMA Specifications

Vehicle Line Geo PRIZM
 Model Year 1997 Issued _____ Revised (#) _____

METRIC (U.S. Customary)

Engine Description
 Engine Code

1.6 LITER L4 (97CID) MULTI-PORT FUEL INJECTION RPO L01

Automatic Transmission/Transaxle

Trade Name		A131L
Type and special features (describe)		2-Mode, 3-Speed Hydraulically Controlled Planetary Gear Train with Lock-Up Clutch
Shift mechanism		
Gear selector	Location (column, floor, other)	Floor
	Lr./No designation (e.g. PRND21)	P-R-N-D-2-L
	Shift interlock (yes, no, describe)	Yes
Gear ratios	1st	2.810
	2nd	1.549
	3rd	1.000
	4th	Not Applicable
	5th	-
	6th	-
	Reverse	2.296
Final drive ratio		
Max. upshift vehicle speed - drive range km/h (mph)		105 (65.2)
Max. upshift engine speed RPM		
Max. lockdown speed - drive range km/h (mph)		99 (61.5)
Min. overdrive speed km/h (mph)		-
Torque converter	Type	
	Torus design	
	Number of elements	3 Elements - 1st Stage, 2-Phases
	Max. ratio at stall	2.3
	Type of cooling (air, liquid)	Liquid
	Nominal diameter	230 mm (9.05 in.)
Capacity factor "K"		-
Pump type		
Lubricant	Capacity refill L (pt.)	2.5 (5.3); Dryfill, 5.5 (11.6)
	Type recommended	ATF Dexron II
Oil cooler (std. opt. N.A., internal, external, air, liquid)		In Radiator, Liquid
Transmission mass kg (lbs.) & case material**		59.2 (130.5), Aluminum Die Cast

All Wheel / 4 Wheel Drive

Not Applicable

Description & type (part-time, full-time, 2/4 shift while moving, mechanical, elect., chain/gear, etc.)		
Transfer case	Manufacturer and model	
	Type and location	
Low-range gear ratio		
System disconnect (describe)		
Center differential	Type (bevel, planetary, w or w/o viscous bias, torsen, etc.)	
	Torque split (% front/rear)	

* Input speed = $\sqrt{\text{torque}}$

** Dry weight including torque converter. If other, specify.

MVMA Specifications

Vehicle Line Geo PRIZM
 Model Year 1997 Issued _____ Revised (#) _____

7

METRIC (U.S. Customary)

Engine Description
 Engine Code

1.8 LITER L4 (108 CID) MULTI-PORT FUEL INJECTION RPO LV6

Automatic Transmission/Transaxle

Trade Name		A245e
Type and special features (describe)		2-Mode, 4-Speed electronically Controlled Planetary Gear Train with Lock-Up Clutch
Shift mechanics		
Gear selector	Location (column, floor, other)	Floor
	Ltr./No. designation (e.g. PRND21)	P-R-N-D-2-L
	Shift interlock (yes, no, describe)	Yes
Gear ratios	1st	3.643
	2nd	2.008
	3rd	1.296
	4th	0.892
	5th	Not Available
	6th	"
	Reverse	2.977
	Final drive ratio	
Max. upshift vehicle speed - drive range km/h (mph)		144 (89.5)
Max. upshift engine speed RPM		
Max. kickdown speed - drive range km/h (mph)		139 (86.4)
Min. overdrive speed km/h (mph)		19 (11.8)
Torque converter	Type	
	Torus design	
	Number of elements	3 Elements - 1st Stage, 2-Phases
	Max. ratio at stall	2.3
	Type of cooling (air, liquid)	Liquid
	Nominal diameter	230 mm (9.05 in.)
Capacity factor "K"		-
Pump type		
Lubricant	Capacity refill L (pt.)	3.3 (7.0); Dryfill, 7.6 (16.1)
	Type recommended	ATF Dexron II
Oil cooler (std., opt., N.A., internal, external, air, liquid)		In Radiator, Liquid
Transmission mass kg (lbs.) & case material**		71.8 (158.3), Aluminum Die Cast

All Wheel / 4 Wheel Drive

Not Applicable

Description & type (part-time, full-time, 2/4 shift while moving, mechanical, elect., chain/gear, etc.)		
Transfer case	Manufacturer and model	
	Type and location	
Low-range gear ratio		
System disconnect (describe)		
Center differential	Type (bevel, planetary w or w/o viscous bias, torsen, etc.)	
	Torque split (% front/rear)	

* Input speed + $\sqrt{\text{torque}}$

** Dry weight including torque converter. If other, specify.

MVMA Specifications

Vehicle Line Geo PRIZM
 Model Year 1996 Issued _____ Revised (®) _____

METRIC (U.S. Customary)

Engine Description
 Engine Code

1.6 LITER L4 (97 CID) MULTI-PORT FUEL INJECTION RPO L01

Axle Ratio and Tooth Combinations (See 'Power Teams' for axle ratio usage)

Effective final drive ratio (or overall top gear ratio)			A/T 3.53
Transfer ratio and method (chain, gear, etc.)			-
Front drive unit	Ring gear o.d.		-
	No. of teeth	Pinion	A/T 19
		Ring gear	A/T 67

Front Drive Unit

Description (integral to trans., etc.)		Integral to Transmission
Limited slip differential (type)		-
Drive pinion	Type	Helical Gear
	Offset	-
No. of differential pinions		2
Pinion / differential	Adjustment (shim, etc.)	-
	Bearing adjustment	-
Driving wheel bearing (type)		Double Row Angular Contact Ball Bearing
Lubricant	Capacity L (pt.)	1.4 (3.0), A/T
	Type recommended	ATF Dexron II
SAE Viscosity Number		

Axle Shafts - Front Wheel Drive

Manufacturer and number used			GM Saginaw. 2
Type (straight, solid bar, tubular, etc.)		Left	Solid Bar
		Right	Solid Bar
Outer diam. x length* x wall thickness	Manual Transaxle	Left	24.2 x 340.1 mm (.953 x 13.4 in.)
		Right	24.2 x 657.3 mm (.953 x 25.9 in.)
	Automatic transaxle	Left	24.2 x 340.1 mm (.953 x 13.4 in.)
		Right	24.2 x 657.3 mm (.953 x 25.9 in.)
	Optional transaxle	Left	-
		Right	-
Slip yoke	Type		-
	Number of teeth		-
	Spline o.d.		-
Universal joints	Make and mtg. no.	Inner	GM Saginaw. 43047-02050. TMC 43403-12040
		Outer	GM Saginaw. 43405-02070, 02080. TMC 43405-12022, 12051
	Number used		4, 2 Each Shaft
	Type, size, plunge	Inner	Tript. Plunge
		Outer	Rzeppa, Fixed
	Attach (u-bolt, clamp, etc.)		Snap Ring
Bearing	Type (plain anti-friction)	-	
	Lubrication (fitting, prepack)	-	
Drive taken through (torque tube, arms or springs)			MacPherson Strut
Torque taken through (torque tube, arms or springs)			Engine Mounting System

* Centerline to centerline of universal joints, or to centerline of attachment.

MVMA Specifications

Vehicle Line Geo PRIZM
 Model Year 1998 Issued _____ Revised (9) _____

METRIC (U.S. Customary)

Engine Description
 Engine Code

1.8 LITER L4 (108 CID) MULTI-PORT FUEL INJECTION RPO LV6

Axle Ratio and Tooth Combinations (See 'Power Teams' for axle ratio usage)

Effective final drive ratio (or overall top gear ratio)		A/T: 2.82
Transfer ratio and method (chain, gear, etc.)		-
Front drive unit	Ring gear o.d.	-
	No. of teeth	Pinion
		Ring gear
		A/T: 28
		A/T: 79

Front Drive Unit

Description (integral to trans., etc.)		Integral to Transmission
Limited slip differential (type)		-
Drive pinion	Type	Helical Gear
	Offset	-
No. of differential pinions		2
Pinion / differential	Adjustment (shim, etc.)	-
	Bearing adjustment	-
Driving wheel bearing (type)		Double Row Angular Contact Ball Bearing
Lubricant	Capacity L (pt.)	Included in Automatic Transmission
	Type recommended	ATF Dextron II
SAE Viscosity Number		

Axle Shafts - Front Wheel Drive

Manufacturer and number used		TMC		
Type (straight, solid bar, tubular, etc.)	Left	Solid Bar		
	Right	Solid Bar		
Outer diam. x length* x wall thickness	Manual Transaxle	Left	22.3 x 354.1 mm (.878 x 13.9 in.)	
		Right	26.0 x 668.6 mm (1.0 x 26.3 in.)	
	Automatic transaxle	Left	22.3 x 354.1 mm (.878 x 13.9 in.)	
		Right	26.0 x 668.6 mm (1.0 x 26.3 in.)	
	Optional transaxle	Left	-	
		Right	-	
Sip yoke	Type	-		
	Number of teeth	-		
	Spline o.d.	-		
Universal joints	Make and mfg. no.	Inner	GM Saginaw, 43047-02050; TMC 43403-12040	
		Outer	GM Saginaw, 43405-02070,02080; TMC 43405-12022, 12051	
	Number used		4, 2 Each Shaft	
	Type, size, plunge	Inner	Tripot, Plunge	
		Outer	Rzeppa, Fixed	
	Attach (u-bolt, clamp, etc.)		Snap Ring	
Bearing	Type (plain anti-friction)	-		
	Lubrication (fitting prepack)	-		
Drive taken through (torque tube, arms or springs)		MacPherson Strut		
Torque taken through (torque tube, arms or springs)		Engine Mounting System		

* Centerline to centerline of universal joints, or to centerline of attachment

MVMA Specifications

Vehicle Line Geo PRIZM
 Model Year 1996 Issued _____ Revised (#) _____

METRIC (U.S. Customary)

Model Code/Description And/Or
 Engine Code/Description

PRIZM	PRIZM LSi
-------	-----------

Suspension - General Including Electronic Controls

Car leveling	Standard/optional/not available	Not Available	
	Manual/automatic control	-	
	Type (air/hydraulic)	-	
	Primary/assist spring	-	
	Rear only/4 wheel leveling	-	
	Single/dual rate spring	-	
	Single/dual ride heights	-	
Shock absorber damping controls	Provision for jacking	Not Available	
	Standard/optional/not available	-	
	Manual/automatic control	-	
	Number of damping rates	-	
	Type of actuation (manual/electric motor/air, etc.)	-	
	Sensors	Lateral acceleration	-
		Deceleration	-
Acceleration		-	
Road surface		-	
Shock absorber (front & rear)	Type	Tube Double Acting	
	Make	Delco	
	Piston diameter	32.0 mm (1.26 in.)	
	Rod diameter	20.0 mm (.79 in.)	

Suspension - Front

Type and description		MacPherson Strut
Travel	Full jounce (define load condition)	80 mm (3.1 in.)
	Full rebound	85 mm (3.35 in.)
Spring	Type (coil, leaf, other & material)	Coil, Alloy Steel
	Insulators (type & material)	Top and Bottom Rubber
	Size (Leaf: length & width, Coil: design height & i.d., Bar: length & diameter)	See Page 11A
	Spring rate N/mm (lb./in.)	22.5 (199.2) 21.6 (191.2)
	Rate at wheel N/mm (lb./in.)	20.6 (182.3) 19.6 (173.5)
Stabilizer	Type (link, linkless, frameless)	-
	Material & O.D. bar/tube, wall thickness	-

Suspension - Rear

Type and description		MacPherson Strut	
Travel	Full jounce (define load condition)	85 mm (3.35 in.)	
	Full rebound	100 mm (3.93 in.)	
Spring	Type (coil, leaf, other & material)	Coil, Alloy Steel	
	Size (Leaf: length & width, Coil: design height & i.d., Bar: length & diameter)	320.5 x (128.6-88.6) 325.5 x (128.5-88.6)	
	Spring rate N/mm (lb./in.)	18.6 (164.6)	
	Rate at wheel N/mm (lb./in.)	17.6 (155.8)	
	Insulators (type & material)	Top & Bottom, Rubber	
	if leaf	No. of leaves	-
		Shackle (comp. or tens.)	-
Stabilizer	Type (link, linkless, frameless)	Link	
	Material & O.D. bar/tube, wall thickness	Alloy Steel, 14 mm (.551 in.)	
Track bar (type)			

MVMA Specifications

Vehicle Line Geo PRIZM
Model Year 1998 Issued _____ Revised (®) _____

METRIC (U.S. Customary)

7

SUPPLEMENTAL PAGE

1) Geo PRIZM

<i>Bodystyle</i>	<i>Transaxle</i>	RH		LH	
		<i>w/o A/C</i>	<i>w/A/C</i>	<i>w/o A/C</i>	<i>w/A/C</i>
Notchback	Manual	310.0 x 127.9	316.5 x 127.9	316.5 x 127.9	323.0 x 127.9
Notchback	Auto	316.5 x 127.9	323.0 x 127.9	323.0 x 127.9	329.5 x 127.9

2) Geo PRIZM LSi

<i>Bodystyle</i>	<i>Transaxle</i>	RH		LH	
		<i>w/o A/C</i>	<i>w/A/C</i>	<i>w/o A/C</i>	<i>w/A/C</i>
All	Manual	323.0 x 127.9	330.0 x 127.9	330.0 x 127.9	336.5 x 127.9
All	Auto	330.0 x 127.9	336.5 x 127.9	336.5 x 127.9	343.5 x 127.9

MVMA Specifications

Vehicle Line Geo PRIZM
 Model Year 1998 Issued _____ Revised (●) _____

METRIC (U.S. Customary)

Model Code/Description And/Or
 Engine Code/Description

ALL MODELS

Brakes - Service

Description			
Manufacturer and brake type (std., opt., n.a.)	Front (disc or drum)	AM BRAKE, Disc, Standard	
	Rear (disc or drum)	AM BRAKE, Drum, Standard	
Valving type (proportion, delay, metering, other)		P-Valve	
Power brake (std., opt., n.a.)		Standard	
Booster type (remote, integral, vac., hyd., etc.)		Integral, Vacuum	
Vacuum	Source (inline, pump, etc.)	Inline	
	Reservoir (volume in. ³)	Not Available	
	Pump-type (elec., gear or belt driven)	"	
Traction assist	Operational speed range	Not Available	
	Type (engine or brake intervention)	"	
Antilock device	Front/rear (std., opt., n.a.)	Front and Rear (Optional)	
	Manufacturer	General Motors Delco Chassis Division	
	Type (electronic, mech.)	Electronic	
	Number sensors or circuits	4	
	Number antilock hydraulic circuits	4	
	Integral or add-on system	Add-On	
	Yaw control (yes, no)	Yes	
Hyd power source (elec., vac., mtr., per., org.)		Electric Motor	
Effective area cm ² (in. ²)*		187/230	
Gross Lining area cm ² (in. ²)** (F/R)		191/230	
Swept area cm ² (in. ²)** (F/R)		1236/377	
Rotor	Outer working diameter	F/R 255/N.A.	
	Inner working diameter	F/R 156/N.A.	
	Thickness	F/R 22/N.A.	
	Material & type (vented/solid)	F/R Cast Iron, Vented/N.A.	
Drum	Diameter & width	F/R N.A./200	
	Type and material	F/R N.A./Cast Iron	
Wheel cylinder bore		54.00/17.46	
Master cylinder	Bore/stroke	F/R 20.6/28 (Normal), 22.2/28 (ABS)	
Pedal arc ratio		3.6	
Line press at 445 N (100 lb.) pedal load (kPa (psi))		11954 (Normal), 12794 (ABS)	
Lining clearance		F/R Self Adjust/Self Adjust	
Brake lining	Front wheel	Bonded or riveted (rivets/seg)	Bonded
		Rivet Size	-
		Manufacturer	NISSHINBO, AKEBONO, AISIN, SUMITOMO, BENDIX
		Lining code *****	-
		Material	Molded Resin
		**** Primary or out-board	117 x 49 x 12 mm (4.6 x 1.9 x .472 in.)
		Size Secondary or in-board	117 x 49 x 12 mm (4.6 x 1.9 x .472 in.)
	Shoe thickness (no lining)	5.5	
	Rear wheel	Bonded or riveted (rivts/seg)	Bonded
		Manufacturer	NISSHINBO, AKEBONO
		Lining code *****	-
		Material	Molded Resin
		**** Primary or out-board	192 x 30 x 4 mm (7.56 x 1.18 x .157 in.)
		Size Secondary or in-board	192 x 30 x 4 mm (7.56 x 1.18 x .157 in.)
Shoe thickness (no lining)		1.6 mm (.063 in.)	

* Excludes rivet holes, grooves, chamfers, etc. ** Includes rivet holes, grooves, chamfers, etc.
 *** Total swept area for four brakes (Drum brake: Widest lining contact width for each brake x its contact circumference)
 (Disc brake: Square of Outer Working Dia. minus Square of inner Working Dia. multiplied by Pi/2 for each brake.)
 **** Size for drum brakes includes length x width x thickness classification. ***** Manufacturer I.D. catalog for formulation designation and coefficient of friction classification.

MVMA Specifications

Vehicle Line Geo PRIZM
 Model Year 1996 Issued _____ Revised (●) _____

7

METRIC (U.S. Customary)

Model Code/Description And/Or
 Engine Code/Description

PRIZM	PRIZM LSi
-------	-----------

Tires And Wheels (Standard)

Tires	Size (service description)		P175/65R14 81S	P185/65R14 85S	
	Type (bias, radial, steel, nylon, etc.)		Radial, Steel		
	Inflation pressure (cold) for recommended max. vehicle load	Front kPa (psi)	210 (30.5)		
		Rear kPa (psi)	210 (30.5)		
Rev./mile at 70 km/h (45 mph)		911	895		
Wheels	Type & material		Steel		
	Rim (size & flange type)		14 x 5 1/2J		
	Wheel offset		45.0 mm (1.77 in.)		
	Attachment	Type (bolt or stud & nut)	Stud & Nut		
		Circle diameter	T115/70D14, 14 x 4T	T135/70D15, 15 x 4T	
Number & size		4-M12 x 1.5			
Spare	Tire and wheel		T115/70D14, 14 x 4T	T135/70D15, 15 x 4T	
	Storage position & location (describe)		Flat in Trunk Room Well		

Tires And Wheels (Optional)

Tire size (service description)		P185/65R14 85S
Type (bias, radial, steel, nylon, etc.)		Radial, Steel
Wheel (type & material)		Aluminum
Rim (size, flange type and offset)		14 x 5 1/2JJ, 45
Tire size (service description)		
Type (bias, radial, steel, nylon, etc.)		
Wheel (type & material)		
Rim (size, flange type and offset)		
Tire size (service description)		
Type (bias, radial, steel, nylon, etc.)		
Wheel (type & material)		
Rim (size, flange type and offset)		
Tire size (service description)		
Type (bias, radial, steel, nylon, etc.)		
Wheel (type & material)		
Rim (size, flange type and offset)		
Spare tire and wheel size		
(if configuration is different than road tire or wheel, describe optional spare tire and/or wheel location & storage position)		T135/70D15, 15 x 4T

Brakes - Parking

Type of control		Hand Operate Type
Location of control		Center Floor
Operates on		Rear Brake
If separate from service brakes	Type (internal or external)	-
	Drum diameter	-
	Lining size (length x width x thickness)	-

MVMA Specifications

Vehicle Line Geo PRIZM
 Model Year 1999 Issued _____ Revised (#) _____

METRIC (U.S. Customary)

Model Code/Description And/Or
 Engine Code/Description

PRIZM

PRIZM LSi

Steering

Manual (std., opt., n.a.)		Standard	Not Applicable		
Power (std., opt., n.a.)		Optional	Standard		
Speed-sensitive (std., opt., n.a.)					
4-wheel steering (std., opt., n.a.)		Not Available			
Adjustable steering wheel/column (tilt, telescope, other)	Type	Non Adjustable	Tilt	Non Adjustable Tilt	
	Manufacturer	TOYOTA or NASTEC	NASTEC	TOYOTA or NASTEC NASTEC	
	(std., opt., n.a.)	Standard	Optional	Standard Optional	
Wheel diameter** (W9) SAE J1100	Manual	380 mm (14.96 in.)			
	Power	380 mm (14.96 in.)			
Turning diameter m (ft.)	Outside front	Wall to wall (l. & r.)	5.2 (17.1)		
		Curb to curb (l. & r.)	4.9 (16.1)		
	Inside rear	Wall to wall (l. & r.)	2.6 (8.5)		
		Curb to curb (l. & r.)	2.6 (8.5)		
Scrub Radius*		8			
Manual	Gear	Type	R & P		
		Manufacturer	KOYO		
	Ratios	Gear			
		Overall	22.7		
No wheel turns (stop to stop)		4.09			
Power	Type (coaxial, elec. hyd., etc.)		Integral		
	Manufacturer		TKS		
	Gear	Type	R & P		
		Ratios	Gear		
	Overall		18.1		
	Pump (drive)		V-Ribbed Belt		
No wheel turns (stop to stop)		3.27			
Linkage	Type		Ackermann		
	Location (front or rear of wheels, other)		Rear of Wheels		
	Tie rods (one or two)		2		
Steering axis	Inclination at camber (deg.)		12 deg. 40'		
	Bearings (type)	Upper	Ball Bearing		
		Lower	Ball Joint		
		Thrust	-		
Steering spindle/knuckle & joint type		MacPherson Strut and Ball Joint			

* The horizontal distance in the front elevation between wheel centerline and kingpin (ball joint) axis at ground

** See Page 23

MVMA Specifications

VEHICLE LINE Geo Prizm
 Model Year 1996 Issued _____ Revised (e) _____

METRIC (U.S. Customary)

Model Code/Description And/Or
 Engine Code/Description

ALL MODELS

Wheel Alignment

Front wheel at curb mass (wt.)	Service checking	Caster (deg.)	1deg. 19' ± 45'
		Camber (deg.)	-11' ± 45'
		Toe-in outside track mm (in.)	1 ± 2
	Service reset*	Caster (deg.)	1 deg. 19' ± 30'
		Camber (deg.)	-11' ± 30'
		Toe-in mm (in.)	1 ± 1
Periodic M.V. inspection	Caster (deg.)	Not Available	
	Camber (deg.)	-	
	Toe-in mm (in.)	-	
Rear wheel at curb mass (wt.)	Service checking	Camber (deg.)	-55' ± 45'
		Toe-in outside track mm (in.)	4 ± 2
		Camber (deg.)	-55' ± 30'
	Service reset*	Toe-in mm (in.)	3 ± 1
		Camber (deg.)	Not Available
	Periodic M.V. insp.	Toe-in mm (in.)	-

* Indicates pre-set, adjustable, trend set or other.

Electrical - Instruments and Equipment

Speedometer	Type (analog, digital, std., opt.)	Analog	
	Trip odometer (std., opt., n.s.)	Standard	
Head-up display	Standard, optional, not available		Not Available
	Type	Secondary, opto-electronic	-
	Speedometer	Digital	-
	Status/warning indicators	Turn signals, high beam, low fuel, check gauges	-
	Brightness control	Day / night mode, adjustable	-
EGR maintenance indicator			-
Charge indicator	Type	Telltale Lamp	
	Warning device (light, audible)	Light	
Temperature indicator	Type	Electric Gauge	
	Warning device (light, audible)	Not Available	
Oil pressure indicator	Type	Telltale Lamp	
	Warning device (light, audible)	Light	
Fuel indicator	Type	Electric Gauge	
	Warning device (light, audible)	Light	
Windshield wiper	Type (standard)	Electric 2-Speed and Mist	
	Type (optional)	Electric 2-Speed with Adjustable Intermittent	
	Blade length	LH = 500 mm; RH = 450 mm	
	Swept area cm ² (in. ²)	6390	
Windshield washer	Type (standard)	Standard Electric Motor	
	Type (optional)	-	
	Fluid level indicator (light, audible)	Not Available	
Rear window wiper, wiper/washer (std., opt., n.s.)		Not Available	
Horn	Type	Electric Vibration	
	Number used	1	
Other			

MVMA Specifications

Vehicle Line Geo PRIZM
 Model Year 1997 Issued _____ Revised (●) _____

METRIC (U.S. Customary)

Engine Code/Description

1.6 LITER L4 (97 CID) MULTI-PORT FUEL INJECTION RPO L01

Electrical - Supply System

Battery	Manufacturer	Delco Remy
	Model, std., (opt.)	55D 23L
	Voltage	12
	Amps at 0° F cold crank	356
	Minutes-reserve capacity	99
	Amps/hrs. -20 hr. rate	60
	Location	Left Front of Engine Compartment
Alternator	Manufacturer	NIPPONDENSO - TENNESSEE
	Rating (idle/max. rpm)	AC 70A
	Ratio (alt. crank/rev.)	2.364
	Output at idle (rpm, park)	-
	Optional (type & rating)	-
Regulator	Type	IC Type

Electrical - Starting System

Motor	Manufacturer	NIPPONDENSO TENNESSEE
	Current drain _____ °C (°F)	-
	Power rating kw (hp)	1.4
Motor drive	Engagement type	Solenoid Shift
	Pinion engages from (front, rear)	Front

Electrical - Ignition System

Type	Electronic (std., opt., n.a.)	Standard	
	Other (specify)	Not Applicable	
Coil	Manufacturer	NIPPONDENSO	
	Model	-	
	Current	Engine stopped - A	0 A
		Engine idling - A	0.5 A
Spark plug	Manufacturer	NIPPONDENSO, NGK	
	Model	K16R-U, BKR5EYA	
	Thread (mm)	14 mm (.551 in.)	
	Tightening torque N-m (lb. ft.)	17.6 (23.9)	
	Gap	0.8 mm (.031 in.)	
	Number per cylinder	1	
Distributor	Manufacturer	NIPPONDENSO	
	Model	-	

Electrical - Suppression

Locations & type	Flame Sprayed Distributor Rotor High Resistance High Tension Cord. High Resistance Spark Plug
------------------	---

MVMA Specifications

Vehicle Line Geo Prizm
 Model Year 1996 Issued _____ Revised (®) _____

7

METRIC (U.S. Customary)

Engine Code/Description

1.8 LITER L4 (108 CID) MULTI-PORT FUEL INJECTION RPO LV6

Electrical - Supply System

Battery	Manufacturer	Delco Remy
	Model, std. (opt.)	55D 23L
	Voltage	12
	Amps at 0° F cold crank	356
	Minutes-reserve capacity	99
	Amps/hrs. -20 hr. rate	60
Location		Left Front of Engine Compartment
Alternator	Manufacturer	NIPPONDENSO - TENNESSEE
	Rating (idle/max. rpm)	AC 70A
	Ratio (alt. crank/rev.)	2.364
	Output at idle (rpm. park)	-
Optional (type & rating)		-
Regulator	Type	IC Type

Electrical - Starting System

Motor	Manufacturer	NIPPONDENSO TENNESSEE
	Current drain _____ °C (°F)	-
	Power rating (w (hp))	1.4
Motor drive	Engagement type	Solenoid Shift
	Pinion engages from (front, rear)	Front

Electrical - Ignition System

Type	Electronic (std., opt., n.a.)	Standard	
	Other (specify)	Not Applicable	
Coil	Manufacturer	NIPPONDENSO	
	Model	-	
	Current	Engine stopped - A	0 A
		Engine idling - A	0.5 A
Spark plug	Manufacturer	NIPPONDENSO, NGK	
	Model	K16R-U, BKR5EYA	
	Thread (mm)	14 mm (.551 in.)	
	Tightening torque N-m (lb. ft.)	17.6 (23.9)	
	Gap	0.8 mm (.031 in.)	
Distributor	Number per cylinder	1	
	Manufacturer	NIPPONDENSO	
Model		-	

Electrical - Suppression

Locations & type	Flame Sprayed Distributor Rotor High Resistance High Tension Cord High Resistance Spark Plug
------------------	--

MVMA Specifications

Vehicle Line Geo Prizm
 Model Year 1999 Issued _____ Revised (#) _____

METRIC (U.S. Customary)

Model Code/Description

ALL MODELS

Body

Structure	Monocoque
Bumper system front - rear	Front: P.P. Facia, Energy Absorber Foam and Reinforcement Rear: Same as Front
Anti-corrosion treatment	Extensive Use of Galvanealed Steel Sheet and Double-Layered Zinc-Iron Alloy Coated Steel Sheet, PVC Sealer, Full Dip Pretreatment Cation ED, PVC Under Coat, Chip Resistant Coat.

Body - Miscellaneous Information

Type of finish (lacquer, enamel, other)	Enamel	
Hood	Material & mass	Steel, 14.5
	Hinge location (front, rear)	Rear
	Type (counterbalance, prop)	Prop
	Release control (internal, external)	Internal
Trunk lid	Material & mass	Steel, 11.3
	Type (counterbalance, other)	Counterbalance
	Internal release control (elec., mech., n.a.)	Mechanical
Hatchback lid	Material & mass	-
	Type (counterbalance, other)	-
	Internal release control (elec., mech., n.a.)	-
Tailgate	Material & mass	-
	Type (drop, lift, door)	-
	Internal release control (elec., mech., n.a.)	-
Vent window control (crank, friction, pivot, power)	Front	-
	Rear	-
Window regulator type (cable, tape, flex drive, etc.)	Front	Cable
	Rear	Arm & Sector Gear
Seat cushion type (e.g., 60/40 bucket, bench, wire, foam, etc.)	Front	Panel Frame + Spring + Foam Pad
	Rear	Wire Frame + Foam Pad
	3rd seat	-
Seat back type (e.g., 60/40 bucket, bench, wire, foam, etc.)	Front	Pipe Frame + Spring + Foam Pad
	Rear	Wire Frame + Foam pad, Pipe Frame + Panel Frame + Foam Pad (LS)
	3rd seat	-

Frame

Type and description (separate frame, unitized frame, partially-unitized frame)	Unitized Frame
---	----------------

MVMA Specifications

Vehicle Line Geo Prizm
 Model Year 1996 issued _____ Revised (#) _____

7

METRIC (U.S. Customary)

Model Code/Description

ALL MODELS

Restraint System

Seating Position			Left	Center	Right
Active	Type & description (lap & shoulder belt, lap belt, etc.) Standard / Optional	First seat	3-Point ELR/Standard	Not Applicable	3-Point ALR-ELR/Standard
		Second seat	3-Point ALR-ELR/Standard	2-Point/Standard	3-Point ALR-ELR/Standard
		Third seat	Not Applicable	Not Applicable	Not Applicable
Passive	Type & description (air bag, motorized 2-point belt, fixed belt, knee bolster, manual-lap belt) Standard / Optional	First seat	Air Bag/Standard	Not Applicable	Air Bag / Standard
		Second seat	Not Applicable	Not Applicable	Not Applicable
		Third seat	Not Applicable	Not Applicable	Not Applicable
Glass		SAE Ref.No.			
Windshield glass exposed surface area cm ² (in. ²)		S1	8410 (1303.6)		
Side glass exposed surface area cm ² (in. ²) - total 2 sides		S2	10880 (1686.4)		
Backlight glass exposed surface area cm ² (in. ²)		S3	7230 (1120.7)		
Total glass exposed surface area cm ² (in. ²)		S4	26520 (4110.6)		
Windshield glass (type/thickness)			Curved-Laminated, 4.7 mm		
Side glass (type/thickness)			Curved-Tempered, 3.5 mm		
Backlight glass (type/thickness)			Curved-Tempered, 3.5 mm		
Tinted (yes/no, location)			Yes		
Solar control (yes/no, coated/batched, location)			Yes		

Headlamps

Description (sealed beam, halogen, replaceable bulb, etc.)	Replaceable, Halogen
Shape	Aerodynamic-Flush Mounted
Lo-beam type (2A1, 2B1, 2C1, etc.)	Not Applicable
Quantity	2
Hi-beam type (1A1, 2A1, 1C1, 2C1, etc.)	Not Applicable
Quantity	2

MVMA Specifications

Vehicle Line
Model Year

Geo PRIZM

1998

Issued

Revised (●)

7

METRIC (U.S. Customary)

Engine Code/Description

ALL MODELS

Climate Control System

Air conditioning (std. opt. man. auto)		Manual - Optional Automatic - Not Available
Condenser	Type	Corrugated Fin and Serpentine Tube Type
	Eff. face area (sq. mm.)	239414
	Fins per inch	Pitch = 3.6 mm
Evaporator	Type	Drawn Cup Type
	Eff. face area (sq. mm.)	52250
	Fins per inch	Pitch = 4.0 mm
Heater core	Material	Copper - Brass
	Eff. face area (sq. mm.)	30690
	Fins per inch	Pitch = 1.8 mm
Compressor	Type	10 PA 15
	Displacement (cc.)	155.3
	Manufacturer	NIPPONDENSO (U.S.A.)
	A/C pulley ratio	0.93
Accumulator	Type	-
	Height (mm.)	-
	Diameter (mm.)	-
Receiver	Type	Normal
	Height (mm.)	187 mm
	Diameter (mm.)	48 mm
Refrigerant control (CCOT, TVS, etc.)		-
Heater water valve (yes / no)		Yes
Refrigerant (R - 12, R - 134a, etc.)		R-134a
Charge level (lbs - oz.)		700 ± 50 g.
Cold engine lockout switch (yes / no)		-
Wide open throttle cutout switch (yes / no)		-

MVMA Specifications

Vehicle Line Geo PRIZM
 Model Year 1996 Issued _____ Revised (®) _____

METRIC (U.S. Customary)

Model Code/Description

ALL

Convenience Equipment (standard, optional, n.a.)

	Clock (digital, analog)	With Radio, Optional
	Compass / thermometer	Not Available
	Console (floor, overhead)	Floor
	Defroster, electric windshield	Standard
	Defroster, electric backlight	Optional
Electronic	Diagnostic monitor (integrated, individual)	Not Available
	Instrument cluster (list instruments)	Not Available
	Keyless entry	-
	Tripmeter (avg. spd., fuel)	-
	Voice alert (list items)	-
	Other	-
	Fuel door lock (remote, key, electric)	Remote
Integrated Child Seating	Std./opt. & location in vehicle	
	Number of occupants	
	Occupant weight/height (min. & max.)	
	Restraint system description (3 or 5-point belts/booster seat capability)	
Lamps	Auto head on/off delay, dimming	Not Available
	Cornering	-
	Courtesy (map, reading)	Without Map Lamp, Standard; With Map Lamp, Optional
	Door lock, ignition	Not Available
	Engine compartment	-
	Fog	-
	Glove compartment	-
	Trunk	Without Trunk Lamp, Standard; With Trunk Lamp, Optional
	Illuminated entry system (list lamps, activation)	Not Available
Other	-	
Mirrors	Day / night (auto., man.)	
	L.H. (remote, power, heated)	Standard, Remote; Optional, Power
	R.H. (convex, remote, power, heated)	Standard, Not Available; Optional, Convex Fix, Convex Power
	Visor vanity (RH / LH, illuminated)	-
	Navigation system (describe)	Not Available
	Parking brake-auto release (warning light)	Not Available

MVMA Specifications

Vehicle Line Geo PRIZM
 Model Year 1997 Issued _____ Revised (®) _____

7

METRIC (U.S. Customary)

Model Code/Description

ALL MODELS

Convenience Equipment (standard, optional, n.a.)

Power equipment	Deck lid (release, pull down)		Not Available
	Door locks (manual, automatic, describe system)		Optional (Manual)
	Seats	2 - 4 - 6 way, etc.	Not Available
		Reclining (R.H., L.H.)	"
		Memory (R.H., L.H., preset recline)	"
		Support (lumbar, hip, thigh, etc.)	"
		Heated (R.H., L.H., other)	"
	Side windows		Optional
Vent windows		Not Available	
Rear windows		"	
Radio systems	Antenna (location, whip, w/shield, power)		Roof
	Standard		Radioless
	Optional	AM, FM, stereo, tape, compact disc, graphic equalizer, theft deterrent, radio prep package, headphone jacks, etc.	AM/FM MPX ETR AM/FM MPX ETR, with Cassette Deck AM/FM MPX ETR, with Cassette, CD
	Speaker (number, location)		Std. - 2, Front Doors; Opt. - 4, Front Doors + Rear Package Tray Opt. - 6, 4 + Outside Mirror Brackets.
Roof, open air or fixed (flip-up, sliding, "T")			Optional, Sliding / Flip-Up
Speed control device			Optional
Speed warning device (light, buzzer, etc.)			Not Available
Tachometer (rpm)			8000
Telephone system (describe)			Not Available
Theft deterrent system			Not Available

Trailer Towing

Towing capable	Yes / No	Yes
Engine / transmission / axle	Std. / Opt.	No
Tow class (I, II, III)*	Std. / Opt.	1 (1500 lbs)
Max gross trailer wgt. (lbs)	Std / Opt.	1500
Max trailer tongue load (lbs)	Std / Opt.	150
Towing package available	Yes / No	No

* Class I - 2 000 lbs Class II - 3,500 lbs Class III - 5 000 lbs

MVMA Specifications

Vehicle Line Geo PRIZM
 Model Year 1996 Issued _____ Revised (#) _____

METRIC (U.S. Customary)

Vehicle Dimensions See Key Sheets for definitions

All dimensions to ground are for comparative purposes only. Dimensions are to be shown for all base body models of each vehicle line. SAE Ref. no. refers to the definition published in SAE Recommended Practice J1100 "Motor Vehicle Dimensions," unless otherwise specified.

Model Code/Description	SAE Ref. No.	ALL MODELS
Width		
Tread (front)	W101	1460 (57.5)
Tread (rear)	W102	1450 (57.1)
Vehicle width	W103	1685 (66.3)
Body width at SgRP (front)	W117	1677 (66.0)
Vehicle width (front doors open)	W120	3363 (132.4)
Vehicle width (rear doors open)	W121	3356 (132.1)
Tumble-home (degrees)	W122	24
Outside mirror width	W410	928.6 (36.6), LH. 1865.9 (73.5), RH

Length

Wheelbase	L101	2465 (97.0)
Vehicle length	L103	4395 (173.0)
Overhang (front)	L104	885 (34.8)
Overhang (rear)	L105	1045 (41.1)
Upper structure length	L123	2660 (104.7)
Rear Wheel C/L "X" coordinate	L127	2465 (97.0)

Height **

Passenger distribution (front/rear)	PD1 2.3	**
Trunk/cargo load		**
Vehicle height	H101	1355 (53.3)
Cowl point to ground	H114	880 (34.6)
Deck point to ground	H138	1010 (39.8)
Rocker panel-front to ground	H112	180 (7.1)
Rocker panel-rear to ground	H111	200 (7.9)
Windshield slope angle (degrees)	H122	30.5
Backlight slope angle (degrees)	H121	25.5

Ground Clearance **

Front bumper to ground	H102	175 (6.9)
Rear bumper to ground	H104	230 (9.1)
Bumper to ground front at curb mass (wt.)	H103	210 (8.3)
Bumper to ground rear at curb mass (wt.)	H105	250 (9.8)
Angle of approach (degrees)	H106	17.0
Angle of departure (degrees)	H107	16.0
Ramp breakover angle (degrees)	H147	14.0
Axle differential to ground (front/rear)	H153	140 (5.5) Front
Min. running ground clearance	H156	120 (4.7)
Location of min. running ground clear		Front Lower Arm Bracket

** All Vehicle Height And Ground Clearance Are Made Using EPA Loaded Vehicle Weight, Loading Conditions. EPA loaded vehicle weight is the base vehicle weight plus all coolant and fluids necessary for operation plus 100% of the fuel capacity plus the weight of all options and accessories which weigh three pounds or more and which are sold on at least 33% of the car line, plus two occupants.

All linear dimensions are in millimeters (inches).

MVMA Specifications

Vehicle Line Geo PRIZM
 Model Year 1996 Issued _____ Revised (#) _____

7

METRIC (U.S. Customary) Vehicle Dimensions

See Key Sheets for definitions

Model Code/Description

SAE
 Ref.
 No.

ALL MODELS

Front Compartment

SgRP front "X" coordinate	L31	1340 (52.8)
Effective head room	H61	977.4 (38.5); With Sunroof - 938.5 (36.9)
Max. effective leg room (accelerator)	L34	1059.6 (41.7)
SgRP to heel point	H30	259.9 (10.2)
SgRP to heel point	L53	877.2 (34.5)
Back angle (degrees)	L40	250
Hip angle (degrees)	L42	97.9
Knee angle (degrees)	L44	128.4
Foot angle (degrees)	L46	80.5
Design H-point front travel	L17	239.1 (9.4)
Normal driving & riding seat track trvl.	L23	239.1 (9.4)
Shoulder room	W3	4374 (54.4) 1319 (51.9)
Hip room	W5	4302.7 (54.3) 1294 (50.9)
Upper body opening to ground	H50	1225.7 (48.3)
Steering wheel maximum diameter**	W9	380 (15.0)
Steering wheel angle (degrees)	H18	25 deg. 09'
Accel. heel pt. to steer. whl. ctr.	L11	420.9 (16.6)
Accel. heel pt. to steer. whl. ctr.	H17	651.4 (25.6)
Undepressed floor covering thickness	H67	23.5 (.925)

Front Compartment Interior Dimensions are Measured with the Seating Reference Point (SgRP) _____ mm forward and _____ mm Upward of Rearmost Position.

Rear Compartment

SgRP point couple distance	L50	730 (28.7)
Effective head room	H63	924.4 (36.4); With Sunroof - 909.2 (35.8)
Min. effective leg room	L51	839.7 (33.1)
SgRP (second to heel)	H31	301.8 (11.9)
Knee clearance	L48	-45.6 (-1.8)
Shoulder room	W4	4266.4 (53.4) 1314 (51.7)
Hip room	W6	4278 (54.9) 1290 (50.8)
Upper body opening to ground	H51	1237.3 (48.7)
Back angle (degrees)	L41	27
Hip angle (degrees)	L43	85
Knee angle (degrees)	L45	79
Foot angle (degrees)	L47	111
Depressed floor covering thickness	H73	5.9 (.232)

Luggage Compartment

Usable luggage capacity L (cu. ft.)	V1	359 (12.68)
Liftover height	H195	670 (26.4)

Interior Volumes (EPA Classification)

Vehicle class	Compact Car
Interior volume index including trunk/cargo (cu. ft.)**	101.0
Trunk/cargo index (cu. ft.)	12.7

* See page 14.

** See definition page 33

All linear dimensions are in millimeters (inches) unless otherwise noted.

*** EPA Loaded Vehicle Weight, Loading Conditions

MVMA Specifications

Vehicle Line Geo PRIZM
 Model Year 1996 Issued _____ Revised (®) _____

7

METRIC (U.S. Customary)

Vehicle Dimensions See Key Sheets for definitions

Model Code/Description

4-DOOR NOTCHBACK

Station Wagon/MPV*
 -Third Seat

SAE
 Ref.
 No.

Not Applicable

Seat facing direction	SD1	
SgRP couple distance	L85	
Shoulder room	W85	
Hip room	W86	
Effective leg room	L86	
Effective head room	H86	
SgRP to heel point	H87	
Knee clearance	L87	
Back angle (degrees)	L88	
Hip angle (degrees)	L89	
Knee angle (degrees)	L90	
Foot angle (degrees)	L91	

Station Wagon/MPV* - Cargo Space

Not Applicable

Cargo length (open front)	L200	
Cargo length (open second)	L201	
Cargo length (closed front)	L202	
Cargo length (closed second)	L203	
Cargo length at belt (front)	L204	
Cargo length at belt (second)	L205	
Cargo width (wheelhouse)	W201	
Rear opening width at floor	W203	
Opening width at belt	W204	
Min. rear opening width above belt	W205	
Cargo height	H201	
Rear opening height	H202	
Tailgate to ground height	H250	
Front seat back to load floor height	H197	
Cargo volume index m ³ (ft. ³)	V2	
Hidden cargo volume index m ³ (ft. ³)	V4	
Cargo volume index-rear of 2-seat	V10	
Cargo volume index*	V6	
Cargo width at floor*	W500	
Maximum cargo height*	H505	

Hatchback - Cargo Space

Not Applicable

Cargo length at front seatback height	L208	
Cargo length at floor (front)	L209	
Cargo length at second seatback height	L210	
Cargo length at floor (second)	L211	
Front seatback to load floor height	H197	
Second seatback to load floor height	H198	
Cargo volume index m ³ (ft. ³)	V3	
Hidden cargo volume index m ³ (ft. ³)	V4	
Cargo volume index - rear of 2-seat	V11	

All linear dimensions are in millimeters (inches) unless otherwise noted.

* MPV - Multipurpose Vehicle

** EPA Loaded Vehicle Weight, Loading Conditions

MVMA Specifications

Vehicle Line Geo PRIZM
 Model Year 1997 Issued _____ Revised (®) _____

7

METRIC (U.S. Customary)

Model Code/
Description

ALL MODELS

Vehicle Fiducial Marks

Fiducial Mark Number*	Define Coordinate Location	
Front	Center of Outer Installation Hole for Seat Track of Front Floor Crossmember (both sides)	
Rear	Center of Seat Belt Anchorage Hole in Center Floor	
NOTE: Provide 3 of 4 Fiducial Mark Locations		
Front	W21**	W5 + 81.5 mm
	L54**	L19 + 90.6 mm
	H81**	H10 + 75.4 mm
	*** H161**	295 mm (11.6 in.)
	*** H163**	270 mm (10.6 in.)
Rear	W22**	W1 + 90 mm
	L55**	L32 + 10 mm
	H82**	H11 + 45 mm
	*** H162**	375 mm (14.8 in.)
	*** H164**	350 mm (13.8 in.)

* Reference - SAE Recommended Practice, J182a, Motor Vehicle Fiducial Marks.

** Reference - SAE Recommended Practice J1100 - Motor Vehicle Dimensions.

*** EPA Loaded Vehicle Weight, Loading Conditions

All linear dimensions are in millimeters (inches) unless otherwise noted.

MVMA Specifications
METRIC (U.S. Customary)

Vehicle Line Geo PRIZM
 Model Year 1998 Issued 7 Revised (0)

		VEHICLE MASS (WEIGHT)				% PASS MASS DISTRIBUTION				
Code	Model	CURB MASS. kg. (lb.)*			Shipping Mass kg (lb)***	ETWC** Code	Pass in Front		Pass in Rear	
		Front	Rear	Total			Front	Rear	Front	Rear
Geo PRIZM	1SK19	645-640	435	1080	1038	O	50	50	16	84
4-Door Notchback Sedan	L01, M/T	(3414)	(940)	(2354)	(2280)					
		1421	959	2381	230	O/P				
Geo PRIZM	1SK19	655-660	430	1085	1050	O	50	50	16	84
4-Door Notchback Sedan	L01, A/T	(3455)	(940)	(2395)	(2332)					
		1416	959	2375	2355					
Geo PRIZM LSi	1SK19	650-645	430	1080	1045	O	50	50	16	84
4-Door Notchback Sedan	LV6, M/T	(3422)	(940)	(2362)	(2290)					
		1433	959	2392	2321					
Geo PRIZM LSi	1SK19	680-675	430	1110	1075	P	50	50	16	84
4-Door Notchback Sedan	LV6, A/T	(4488)	(940)	(2428)	(2366)					
		1499	959	2458	2389					

* Reference - SAE J1100 Motor vehicle dimensions, curb weight definition
 ** ETWC - Equivalent Test Weight Class - basis for U.S. Environmental Protection Agency emission certifications
 Refer to ETWC code legend below for test weight class.

ETWC LEGEND

A = 1000	I = 2000	Q = 3000	Y = 4000
B = 1125	J = 2125	R = 3125	Z = 4250
C = 1250	K = 2250	S = 3250	AA = 4500
D = 1375	L = 2375	T = 3375	BB = 4750
E = 1500	M = 2500	U = 3500	CC = 5000
F = 1625	N = 2625	V = 3625	DD = 5250
G = 1750	O = 2750	W = 3750	EE = 5500
H = 1875	P = 2875	X = 3875	FF = 5750

*** Shipping Mass (weight) = Curb Weight Less

32 (71)



1
2
3



AAMA Specifications METRIC (U.S. Customary)

Exterior Vehicle And Body Dimensions - Key Sheet

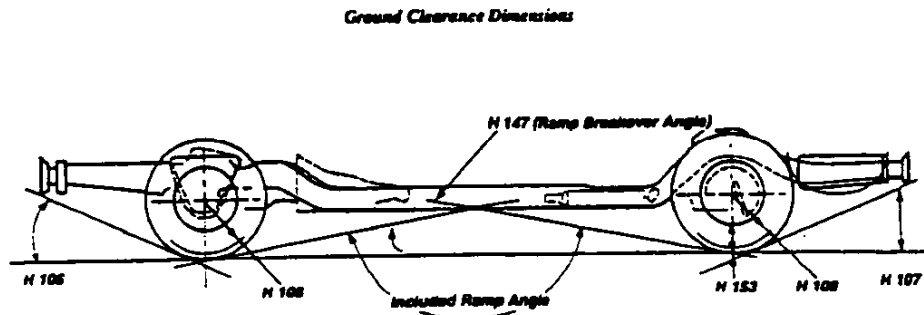
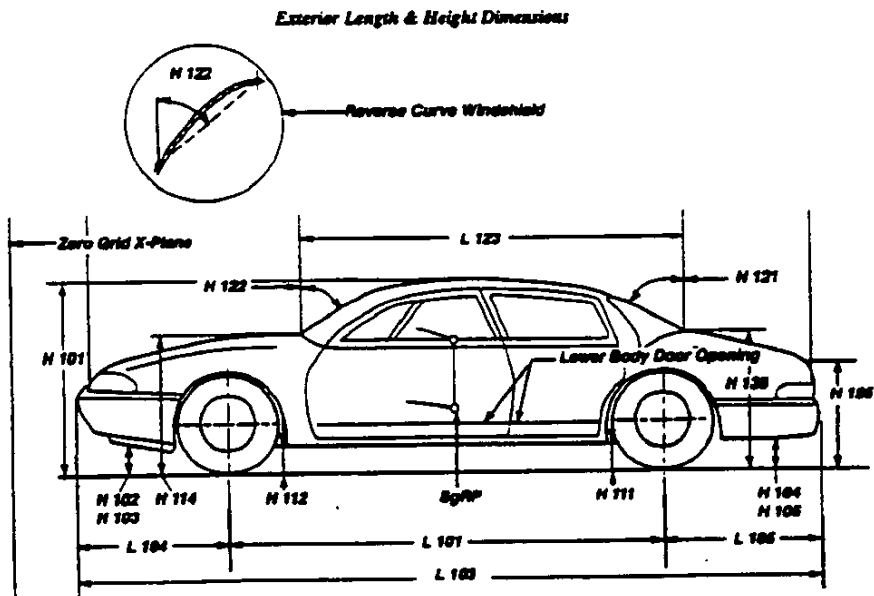
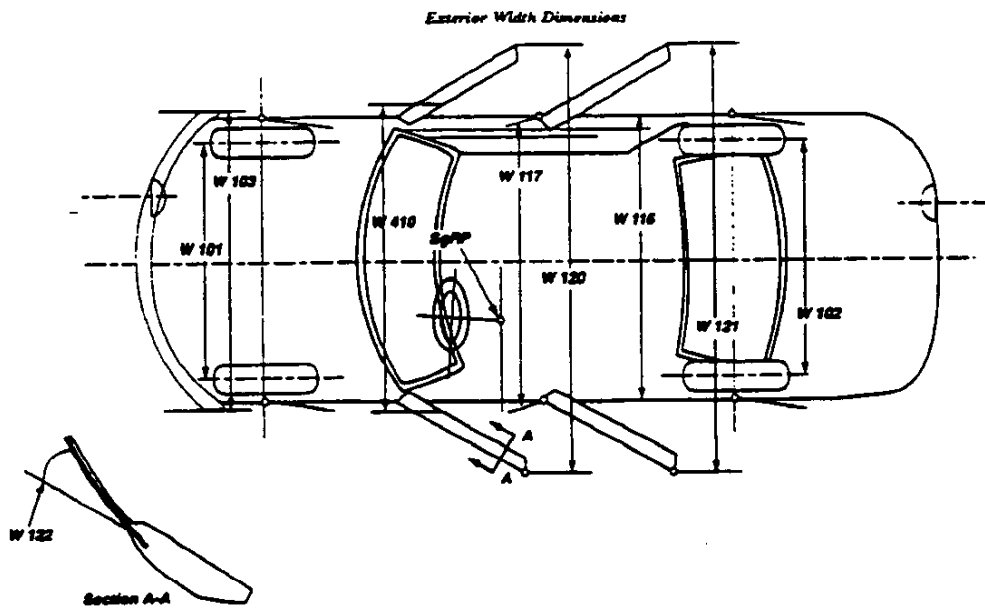

AAMA Specifications
METRIC (U.S. Customary)

Interior Vehicle And Body Dimensions - Key Sheet

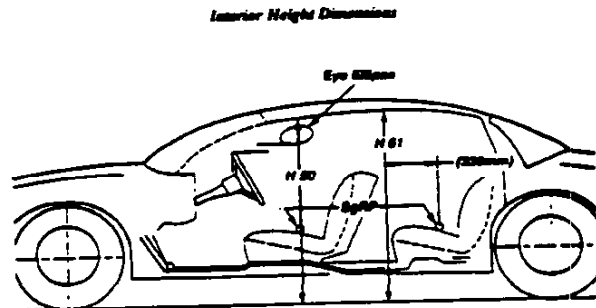
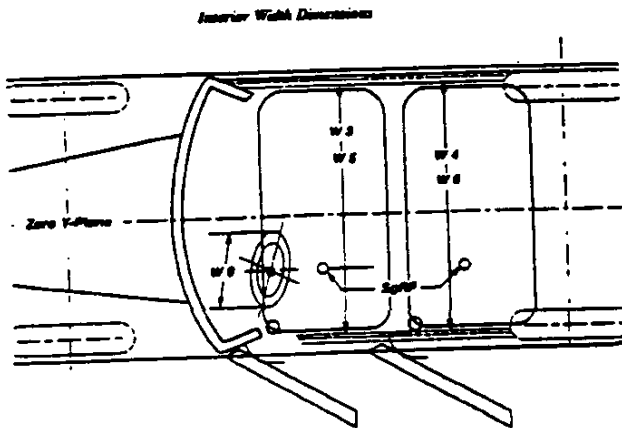
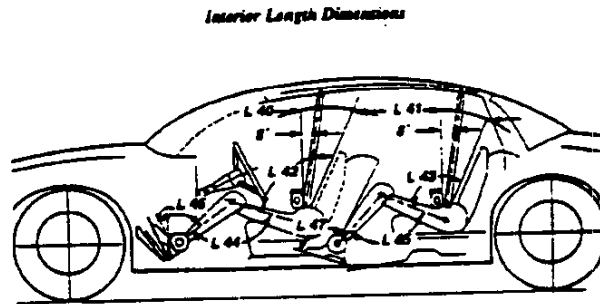
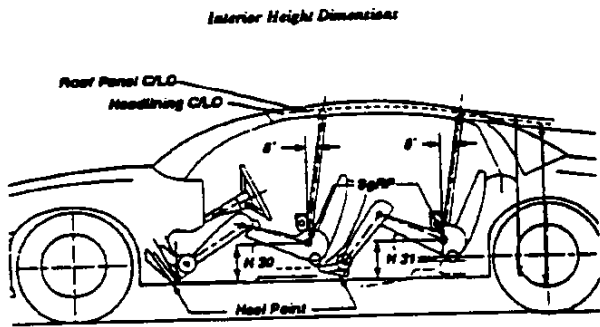
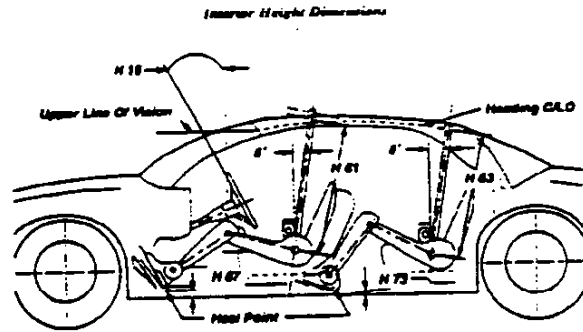
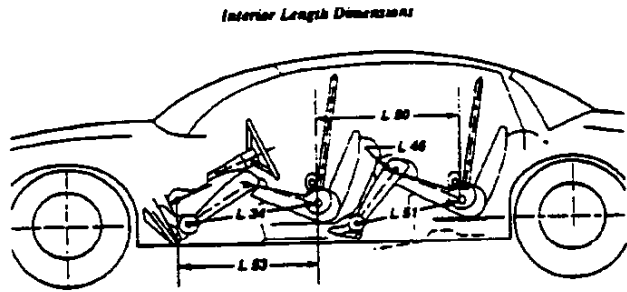

AAMA Specifications

METRIC (U. S. Customary)

Exterior Vehicle And Body Dimensions - Key Sheet

Dimensions Definitions

Seating Reference Point

SEATING REFERENCE POINT means the manufacturer's design reference point which -
 (a) Establishes the rearmost normal design driving or riding position of each designated seating position in a vehicle;
 (b) Has coordinates established relative to the design vehicle structure;
 (c) Simulates the position of the pivot center of the human torso and thigh; and
 (d) is the reference point employed to position the two dimensional templates described in SAE Recommended Practice J826, "Devices for Use in Defining and Measuring Vehicle Seating Accommodations."

Width Dimensions

- W101 TREAD-FRONT.** The dimension measured between the tire centerlines at the ground.
- W102 TREAD-REAR.** The dimension measured between the tire centerlines at the ground. In case of dual wheels, the dimension will be measured to the centerline of tire and wheel assemblies.
- W103 VEHICLE WIDTH.** The maximum dimension measured between the widest point on the vehicle, excluding exterior mirrors, flexible mud flaps, marker lamps, but including bumpers, moldings, sheet metal protrusions or dual wheels, if standard equipment.
- W117 BODY WIDTH AT SgRP-FRONT.** The dimension measured laterally between the widest points on the body at the SGRP-front, excluding door handles, applied moldings, or appliques.
- W120 VEHICLE WIDTH-FRONT DOORS OPEN.** The dimension measured between the widest point on the rear doors in maximum hold-open position.
- W121 VEHICLE WIDTH-REAR DOORS OPEN.** The dimension measured between the widest point on the rear doors in maximum hold-open position. For vehicles with a rear door on only one side, this dimension is to the zero "Y" plane.
- W122 TUMBLE-HOME. STRAIGHT SIDE GLASS.** The angle measured from a vertical to the outside surface of the front door glass at the SGRP "X" plane.
CURVED SIDE GLASS. The angle measured from a vertical to a chord extending from the upper DLO to the lower DLO at the outside surface of the front door glass at the front SGRP "X" plane.
- W410 OUTSIDE MIRROR WIDTH:** The dimension between the widest point on the outside mirrors. The standard right and left mirror adjusted for normal driving will be shown unless otherwise noted. When only one outside mirror is standard, the dimension will be to the zero "Y" plane.

Length Dimensions

- L101 WHEELBASE (WB).** The dimension measured longitudinally between front and rear wheel centerline. In case of dual rear axles, the dimension shall be to the midpoint of the centerlines of the rear wheels.
- L103 VEHICLE LENGTH.** The maximum dimension measured longitudinally between the foremost point and the rearmost point on the vehicle, including bumper, bumper guards, tow hooks and/or rub strips, if standard equipment.
- L104 OVERHANG-FRONT.** The dimension measured longitudinally from the centerline of the front wheels to the foremost point on the vehicle including bumper, bumper guards, tow hook and/or rub strips, if standard equipment.
- L105 OVERHANG-REAR.** The dimension measured longitudinally from the centerline of the rear wheels; or in the case of dual rear axles, the dimension shall be the midpoint of the centerlines of the rear wheels, to the rearmost point on the vehicle including rear bumpers, bumper guards, tow hooks and rub strips, if standard equipment.
- L123 UPPER STRUCTURE LENGTH.** The dimension measured longitudinally from the cowl point to the deck point.

- L127 REAR WHEEL CENTERLINE "x" COORDINATE** or in the case of dual rear axles, the coordinate shall be the midpoint of the distance between the rear axle centerlines.

Height Dimensions

- H101 VEHICLE HEIGHT.** The dimension measured vertically from the highest point on the vehicle body to ground.
- H111 ROCKER PANEL-REAR TO GROUND.** The dimension measured vertically from the bottom of the rocker or side quarter panel at the front of the rear wheel opening, excluding flanges, to ground.
- H112 ROCKER PANEL-FRONT TO GROUND.** The dimension measured vertically from the foremost point on the bottom of the rocker panels, excluding flanges, to ground.
- H114 COWL POINT TO GROUND.** Measured at zero "Y" plane.
- H121 BACKLIGHT SLOPE ANGLE.** The angle between the vertical reference line and the surface of backlight at vehicle zero "Y" plane. For curve backlight, the angle is to chord of backlight arc from lower DLO to upper DLO.
- H122 WINDSHIELD SLOPE ANGLE.** The angle between the vertical reference line and a chord of the windshield arc running from the lower DLO to the upper DLO at the vehicle zero "Y" plane. In the case of wrap over glass, the angle to be measured will be formed by a chord 457 mm (18.0 in.) long drawn from the lower DLO to the intersecting point on the windshield.
- H138 DECK POINT TO GROUND.** Measured at zero "Y" plane.
- H109 STATICLOAD-TIRE RADIUS-REAR.** Specified by the manufacturer in accordance with composite TIRE SECTION STANDARD.

Ground Clearance Dimensions

- H102 FRONT BUMPER TO GROUND.** The minimum dimension measured vertically from the lowest point on the front bumper to ground, including bumper guards, if standard equipment.
- H103 FRONT BUMPERTO GROUND-CURBMASS(WT.).** Measured in the same manner as H102.
- H104 REAR BUMPER TO GROUND.** The minimum dimension measured vertically from the lowest point on the rear bumper to ground, including bumper guards, if standard equipment.
- H105 REAR BUMPER TO GROUND-CURB MASS(WT.).** Measured in the same manner as H104.
- H106 ANGLE OF APPROACH.** The angle measured between a line tangent to the front tire static loaded radius arc and the initial point of structural interference forward of the front tire to ground. The limiting structural component shall be designated.
- H107 ANGLE OF DEPARTURE.** The angle measured between a line tangent to the rear tire static loaded radius arc and the initial point of structural interference rearward of the rear tire to ground. The limiting component shall be designated.
- H147 RAMP BREAKOVER ANGLE.** The angle measured between two lines tangent to the front and rear tire static loaded radius and intersecting at a point on the underside of the vehicle which defines the largest ramp over which the vehicle can roll.
- H153 REAR AXLE DIFFERENTIAL TO GROUND.** The minimum dimension measured from the rear axle differential to ground.
- H156 MINIMUM RUNNING GROUND CLEARANCE.** The minimum dimension measured from the sprung vehicle to ground. Specify location.

AAMA Specifications

METRIC (U. S. Customary)

Interior Vehicle And Body Dimensions - Key Sheet

Dimensions Definitions

Glass Areas

- S1 Windshield area.
 S2 Side windows area. Includes the front door, rear door, vents, and rear quarter windows on both sides of the vehicle.
 S3 Backlight areas.
 S4 Total area. Total of all areas (S1 + S2 + S3).

Fiducial Mark Dimensions

- Fiducial Mark - Number 1
 L54 "X" coordinate.
 W21 "Y" coordinate.
 H81 "Z" coordinate.
 H161 Height "Z" coordinate to ground at curb weight.
 H163 Height "Z" coordinate to ground.
 Fiducial Mark - Number 2
 L55 "X" coordinate.
 W22 "Y" coordinate.
 H82 "Z" coordinate.
 H162 Height "Z" coordinate to ground at curb weight.
 H164 Height "Z" coordinate to ground.

Front Compartment Dimensions

- L11 ACCELERATOR WHEEL POINT TO STEERING WHEEL CENTER. The dimension measured horizontally from the AHP to the intersection of the steering column centerline and a plane tangent to the upper surface of the steering wheel rim.
 L17 DESIGN-H-POINT-FRONT TRAVEL. The dimension measured horizontally between the design H-point-front in the foremost and rearmost seat track positions. (See SAE J1100)
 L23 NORMAL DRIVING AND RIDING SEAT TRACK TRAVEL. The dimension measured horizontally between a point on the design H-point travel line from the SgRP to the displaced point on the design H-point travel line with the seat moved to the foremost seat position, but not to include seat track travel used for purposes other than normal driving and riding positions. (See SAE J1100).
 L31 SgRP-Front. "X" Coordinated.
 L34 MAXIMUM EFFECTIVE LEG ROOM-ACCELERATOR. The dimension measured along a line from the ankle pivot center to the SgRP-front plus 254 mm (10.0 in.) measured with right foot on the underdepressed accelerator pedal. For vehicles with SgRP to heel (H30) greater than 18 in., the accelerator pedal may be depressed as specified by the manufacturer. If the accelerator is depressed, the manufacturer shall place foot flat on pedal and note the depression of the pedal.
 L40 BACK ANGLE-FRONT. The angle measured between a vertical line through the SgRP-front and the torso line. If the seatback is adjustable, use the normal driving and riding position specified by the manufacturer.
 L42 HIP ANGLE-FRONT. The angle measured between torso line and thigh centerline.
 L44 KNEE ANGLE-FRONT. The angle measured between thigh centerline and lower leg centerline measured on the right leg.
 L46 FOOT ANGLE-FRONT. The angle measured between the lower leg centerline and a line tangent to the ball and heel of the bare foot flesh line measured on the right leg. Ref SAE J826.
 L53 SgRP-FRONT TO HEEL. The dimension measured horizontally from the SgRP-front to the accelerator heel point.
 W3 SHOULDER ROOM-FRONT. The minimum dimension measured laterally between the trimmed surfaces on the "X" plane through the SgRP-front at height between the belt line and 254 mm (10.0 in.) above the SgRP-front, excluding the door assist strap and attaching parts.

- W5 HIP ROOM-FRONT. The minimum dimension measured laterally between the trimmed surfaces on the "X" plane through the SgRP-front within 25 mm (1.0 in.) below and 76 mm (3.0 in.) above the SgRP-front and 76 mm (3.0 in.) fore and aft of the SgRP-front.
 W9 STEERING WHEEL MAXIMUM OUTSIDE DIAMETER. Define if other than round.
 H7 ACCELERATOR HEEL POINT TO THE STEERING WHEEL CENTER. The dimension measured vertically from the AHP-front to the intersection of the steering column centerline to a plane tangent to the upper surface of the steering wheel rim.
 H18 STEERING WHEEL ANGLE. The angle measured from a vertical to the surface plane of the steering wheel.
 H30 SgRP-FRONT TO HEEL. The dimension measured vertically from the SgRP-front to the accelerator heel point.
 H50 UPPER BODY OPENING TO GROUND-FRONT. The dimension measured vertically from the trimmed body opening to the ground on the SgRP-front "X" plane.
 H61 EFFECTIVE HEAD ROOM-FRONT. The dimension measured along a line 8 deg. rear of vertical from the SgRP-front to the headlining plus 102 mm (4.0 in.).
 H67 FLOOR COVERING THICKNESS - UNDEPRESSED - FRONT. The dimension measured vertically from the surface of the underdepressed floor covering to the underbody sheet metal at the accelerator heel point.

Rear Compartment Dimensions

- L41 BACK ANGLE-SECOND. The angle measured between a vertical line through the SgRP-second and the torso line.
 L43 HIP ANGLE-SECOND. The angle measured between torso line and thigh centerline.
 L45 KNEE ANGLE-SECOND. The angle measured between thigh centerline and lower leg centerline.
 L47 FOOT ANGLE-SECOND. The angle measured between the lower leg centerline and a line tangent to the ball and heel of the three-dimensional devices bare foot flesh line (Reference J826).
 L48 KNEE CLEARANCE-SECOND. The minimum dimension measured from the knee pivot center to the back of the front seatback minus 51 mm (2.0 in.).
 L50 SgRP COUPLE DISTANCE-SECOND. The dimension measured horizontally from the driver SgRP-front to the SgRP-second.
 L51 MINIMUM EFFECTIVE LEG ROOM-SECOND. The dimension measured along a line from the ankle pivot center to the SgRP-second plus 254 mm (10.0 in.).
 W4 SHOULDER ROOM-SECOND. The minimum dimension measured laterally between door or quarter trimmed surfaces on the "X" plane through the SgRP-second at height between 254-406 mm (10.0-16.0 in.) above the SgRP-second, excluding the door assist straps and attaching parts.
 W6 HIP ROOM-SECOND. Measured in the same manner as W5.
 H31 SgRP-SECOND TO HEEL. The dimension measured vertically from the SgRP-second to the two dimensional device heel point on the depressed floor covering.
 H51 UPPER BODY OPENING TO GROUND-SECOND. The dimension measured vertically from the trimmed body opening to the ground on the "X" plane 330 mm (13.0 in.) forward of the SgRP-second.
 H63 EFFECTIVE HEAD ROOM-SECOND. The dimension measured along a line 8 deg. rear of vertical from the SgRP to the headlining, plus 102 mm (4.0 in.).
 H73 FLOOR COVERING-DEPRESSED-SECOND. The dimension measured vertically from the heel point to the underbody sheet metal.

AAMA Specifications

METRIC (U. S. Customary)

Interior Vehicle And Body Dimensions - Key Sheet

Dimensions Definitions

Luggage Compartment Dimensions

V1 **USABLE LUGGAGE CAPACITY**-Total of volumes of individual pieces of standard luggage set plus H-boxes stowed in the luggage compartment in accordance with the procedure described in paragraph 8.2 of SAE-J1100a.

Interior Volumes (EPA Classification)

The Interior Index is listed for each body style except two seater. The Interior Volume Index estimates the space in a car. It is based on four measurements - head room, shoulder room, hip room, and leg room - for the front and rear seats, plus trunk capacity.

The Trunk/Cargo Index is an estimate of the size of the trunk/cargo space. In station wagons and hatchbacks it is an estimate of the space behind the second seat.

Station Wagon/MPV - Third Seat Dimensions

L85 **SgRP COUPLE DISTANCE-THIRD.** The dimension measured horizontally from the SgRP-second to the SgRP-third.

L86 **EFFECTIVE LEG ROOM-THIRD.** The dimension measured along a line from the ankle pivot center to the SgRP-third plus 254 mm (10.0 in.).

L87 **KNEE CLEARANCE-THIRD.** The minimum dimension from the knee pivot center to the back of second seatback minus a constant of 51 mm (2.0 in.). With rear-facing third seat, dimension is measured to closure.

L88 **BACK ANGLE-THIRD.** Measured in the same manner as L41.

L89 **HIP ANGLE-THIRD.** Measured in the same manner as L43.

L90 **KNEE ANGLE-THIRD.** Measured in the same manner as L45.

L91 **FOOT ANGLE-THIRD.** Measured in the same manner as L47.

W85 **SHOULDER ROOM-THIRD.** Measured in the same manner as W4.

W86 **HIP ROOM-THIRD.** Measured in the same manner as W5.

H86 **EFFECTIVE HEAD ROOM-THIRD.** The dimension, measured along a line 8 deg. from the SgRP-third to the headlining rear of vertical plus a constant of 102 mm (4.0 in.).

H87 **SgRP-THIRD TO HEEL POINT**

SD1 **SEAT FACING DIRECTION-THIRD.**

Station Wagon/MPV - Cargo Space Dimensions

L200 **CARGO LENGTH-OPEN-FRONT.** The minimum dimension measured longitudinally from the back of the front seatback at the height of the undepressed floor covering to the rearmost point on the undepressed floor covering on the open tailgate or cargo surface if the rear closure is a conventional door type tailgate at the zero "Y" plane.

L201 **CARGO LENGTH-OPEN-SECOND.** The dimension measured longitudinally from the back of the second seatback at the height of the undepressed floor covering on the open tailgate or cargo floor surface if the rear closure is a conventional door type tailgate, at the zero "Y" plane.

L202 **CARGO LENGTH-CLOSED-FRONT.** The minimum dimension measured horizontally from the back of the front seat at the height of the undepressed floor covering to the rearmost point on the undepressed floor covering on the closed tailgate or taildoor for station wagons, trucks and mpv's at the zero "Y" plane.

L203 **CARGO LENGTH-CLOSED-SECOND.** The dimension measured horizontally from the back of the second seat at the height of the undepressed floor covering to the rearmost point on the undepressed floor covering on the closed tailgate or taildoor for station wagons, trucks and mpv's at the zero "Y" plane.

L204 **CARGO LENGTH AT BELT-FRONT.** The minimum dimension measured horizontally from the back of the front seatback at the seatback top to the foremost normal surface of the closed tailgate or inside surface of the cab backpanel at the height of the belt, on the zero "Y" plane.

L205 **CARGO LENGTH AT BELT-SECOND.** The minimum dimension measured horizontally from the back of the second seatback top to the foremost normal surface of the closed tailgate at the height of the belt, on the zero "Y" plane.

W201 **CARGO WIDTH-WHEELHOUSE.** The minimum dimension measured laterally between the trimmed wheelhousings at floor level. For any vehicle not trimmed, measure to the sheet metal.

W203 **REAR OPENING WIDTH AT FLOOR.** The minimum dimension measured laterally between the limiting interferences of the rear opening at floor level.

W204 **REAR OPENING WIDTH AT BELT.** The minimum dimension measured laterally between the limiting interferences of the rear opening at belt height or top of pick up box.

W205 **REAR OPENING WIDTH ABOVE BELT.** The minimum dimension measured laterally between the limiting interferences of the rear opening above the belt height.

W500 **CARGO WIDTH AT FLOOR.** The maximum dimension measured laterally between the limiting interferences at the floor level. This dimension shall include ribs and pillars, but will exclude wheelhouses.

H197 **FRONT SEATBACK TO LOAD FLOOR HEIGHT.** The dimension measured vertically from the horizontal tangent to the top of the seatback to the undepressed floor covering.

H201 **CARGO HEIGHT.** The dimension measured vertically from the top of the undepressed floor covering to the headlining at the rear wheel "X" coordinate on the zero "Y" plane.

H202 **REAR OPENING HEIGHT.** The dimension measured vertically from the top of the undepressed floor covering to the upper trimmed opening on the zero "Y" plane with rear door fully open.

H250 **TAILGATE TO GROUND CURB MASS (WT.)** The dimension measured vertically from the top of the undepressed floor covering on the lowered tailgate to ground on the zero "Y" plane.

H505 **MAXIMUM CARGO HEIGHT.** The maximum vertical dimension rear of the front seat from the cargo floor to roof bow or headlining at the zero "Y" plane.

AAMA Specifications

METRIC (U. S. Customary)

Interior Vehicle And Body Dimensions - Key Sheet

Dimensions Definitions

<p>V2 STATION WAGON Measured in inches:</p> $\frac{W4 \times H201 \times L204}{1728} = \text{ft.}^3$ <p>Measured in mm:</p> $\frac{W4 \times H201 \times L204}{10^9} = \text{m}^3(\text{cubicmeter})$	<p>L208 CARGO LENGTH AT FRONT SEATBACK HEIGHT. The minimum horizontal dimension from the "X" plane tangent to the rearmost surface of the driver's seatback to the inside limiting interference of the hatchback door on the vehicle zero "Y" plane.</p> <p>L209 CARGO LENGTH AT FLOOR-FRONT. The minimum horizontal dimension measured at floor level from the rear of the front seatback to the normal limiting interference of the hatchback door on the vehicle zero "Y" plane.</p> <p>L210 CARGO LENGTH AT SECOND SEATBACK HEIGHT. The minimum dimension measured from the "X" plane tangent to the rearmost surface of second seatback or the load floor which is towed at least one half of the H198 dimension height above the rear load floor, to the rearmost inside limiting interference on the zero "X" plane.</p>
<p>V4 HIDDEN LUGGAGE CAPACITY-REAR OF FRONT SEAT. The total volumes of individual pieces of one set of standard luggage stowed in any hidden cargo area below the load floor rear of the front seat.</p>	<p>L211 CARGO LENGTH AT FLOOR-SECOND SEATBACK. The minimum horizontal dimension measured at floor level from the rear of the second seatback or load floor panel to the normal limiting interference of the hatchback door on the vehicle zero "Y" plane.</p>
<p>V5 TRUCKS AND MPV'S WITH OPEN AREA. Measured in inches:</p> $\frac{L506 \times W505 \times H503}{1728} = \text{ft.}^3$ <p>Measured in mm:</p> $\frac{L506 \times W500 \times H503}{10^9} = \text{m}^3(\text{cubicmeter})$	<p>H197 FRONT SEATBACK TO LOAD HEIGHT. The dimension measured vertically from the horizontal tangent to the top of the seatback to the undepressed floor covering.</p> <p>H198 SECOND SEATBACK TO LOAD FLOOR HEIGHT. The dimension measured vertically from the second seatback to the undepressed floor covering.</p>
<p>V6 TRUCKS AND MPV'S WITH CLOSED AREA. Measured in inches:</p> $\frac{L204 \times W500 \times H505}{1728} = \text{ft.}^3$ <p>Measured in mm:</p> $\frac{L204 \times W500 \times H505}{10^9} = \text{m}^3(\text{cubicmeter})$	<p>V3 HATCHBACK. Measured in inches:</p> $\frac{\frac{L208+L209}{2} \times W4 \times H197}{1728} = \text{ft.}^3$ <p>Measured in mm:</p> $\frac{\frac{L208+L209}{2} \times W4 \times H197}{10^9} = \text{m}^3(\text{cubicmeter})$
<p>V8 HIDDEN LUGGAGE CAPACITY-REAR OF SECOND SEAT. The total volume of individual pieces of one set of standard luggage stowed in any hidden cargo area below the load floor rear of the second seat.</p>	<p>V4 HIDDEN LUGGAGE CAPACITY-REAR OF FRONT SEAT. The total volumes of individual pieces of one set of standard luggage stowed in any hidden cargo area below the load floor rear of the front seat.</p>
<p>V10 STATION WAGON CARGO VOLUME INDEX. Measured in inches:</p> $\frac{H201 \times L205 \times \frac{W4+W201}{2}}{1728} = \text{ft.}^3$ <p>Measured in mm:</p> $\frac{H201 \times L205 \times \frac{W4+W201}{2}}{10^9} = \text{m}^3(\text{cubicmeter})$	<p>V11 HATCHBACK CARGO VOLUME INDEX. Usable luggage (one (1) stand and luggage set) below floor: Measured in inches:</p> $\frac{\frac{L210+L211}{2} \times W4 \times H198}{1728} = \text{ft.}^3$ <p>Measured in mm:</p> $\frac{\frac{L210+L211}{2} \times W4 \times H198}{10^9} = \text{m}^3(\text{cubicmeter})$

Hatchback - Cargo Space Dimensions

All Hatchback cargo dimensions are to be taken with the front seat in full down and rear position, and the rear seat folded down. The hatchback door is in the closed position. (For electronically adjusted seats, see the manufacturer's specifications for Design "H" Point).

AAMA Specifications

METRIC (U. S. Customary)

Index

Subject	Page No.	Subject	Page No.
Alternator	16	Passenger Capacity	1
Axle, Drive, Front, Rear, All Four	2, 9, 10	Passenger Mass Distribution	26
Axle Shafts	10	Pistons	3
Battery	16	Power Brakes	12
Body and Miscellaneous Information	17	Power Engine	2
Brakes-Parking Service	12, 13	Power Steering	14
Camber	15	Power Teams	2
Camshaft	3	Propeller Shaft	10
Capacities		Pumps-Fuel	6
Cooling System	5	Water	5
Fuel Tank	6	Radiator-Cap, Hoses, Core	5
Lubricants		Ratios-Axle, Transaxle	2,9,10
Engine Crankcase	4	Compression	2
Transmission/Transaxle	8,9	Steering	14
Rear Axle	10	Transmission/Transaxle	2,8,9
Carburetor	2,6	Rear Axle	2,10
Caster	15	Regulator-Alternator	16
Climate Control System	19	Restraint System	18
Clutch-Pedal Operated	8	Rims	13
Coil, Ignition	18	Rods-Connecting	4
Connecting Rods	4	Scrub Radius	14
Convenience Equipment	20-21	Seats	17
Cooling System	5	Shock Absorbers, Front & Rear	11
Crankshaft	4	Spark Plugs	16
Cylinders and Cylinder Head	3	Speedometer	15
Diesel Information	4	Springs-Front & Rear Suspension	11
Dimension Definitions		Stabilizer (Sway Bar)-Front & Rear	11
Key Sheet-Exterior	28,31,32	Starting System	16
Key Sheet-Interior	29,30,32,33,34	Steering	14
Electrical System	15,16	Suppression-Ignition, Radio	16
Emission Controls	7	Suspension-Front & Rear	11
Engine-General		Tail Pipe	7
Bore, Strokes, Type	3	Theft Protection	21
Compression Ratio	2	Thermostat, Cooling	5
Displacement	2,3	Tires	13
Firing Order, Cylinder Numbering	3	Toe-In	15
General Information, Power & Torque	2	Torque Converter	9
Intake System	4	Torque-Engine	2,8,9
Power Teams	2	Trailer Towing	21
Exhaust System	7	Transaxle	9
Equipment Availability, Convenience	20	Transmission-Types	2,8,9
Fan, Cooling	5	Transmission-Automatic	2,9
Filters - Engine Oil, Fuel System	4	Transmission-Manual	2,8
Four Wheel Drive	10	Transmission-Ratios	2,8,9
Frame	17	Tread	22
Front Suspension	11	Trunk Cargo Load	1
Front Wheel Drive Unit	10	Trunk Luggage capacity	23
Fuel Economy, EPA	1	Turning Diameter	14
Fuel Injection	6	Unriveted Construction	18
Fuel System	6	Universal Joints, Propeller Shaft	10
Fuel Tank	6	Valve System	4
Glass	18	Vehicle Dimensions	
Headlamps	18	Width	22
Headroom-Body	23,24	Length	22
Heights	22	Height	22
Horns	15	Ground Clearance	22
Horsepower-Brake	2	Front Compartment	23
Ignition System	16	Rear Compartment	23
Inflation-Tires	13	Luggage Compartment	23
Interior Volumes	23	Station Wagon-Third Seat	24
Instruments	15	Station Wagon-Cargo Space	24
Legroom	23,24	Hatchback-Cargo Space	24
Lengths	22	Fiducial Marks	25
Leveling,Suspension	11	Voltage Regulator	16
Lifters, Valves	4	Water Pump	5
Linings-Clutch, Brake	8,12	Weights	26,27
Lubrication-Engine Transmission/Transaxle	4,8,9	Wheel Alignment	15
Luggage Compartment	23	Wheelbase	22
Models	1	Wheels & Tires	13
Motor Starting	16	Wheel Spindle	14
Muffler	7	Widths	22
Origin	1	Windshield	18
		Windshield Wiper and Washer	15